

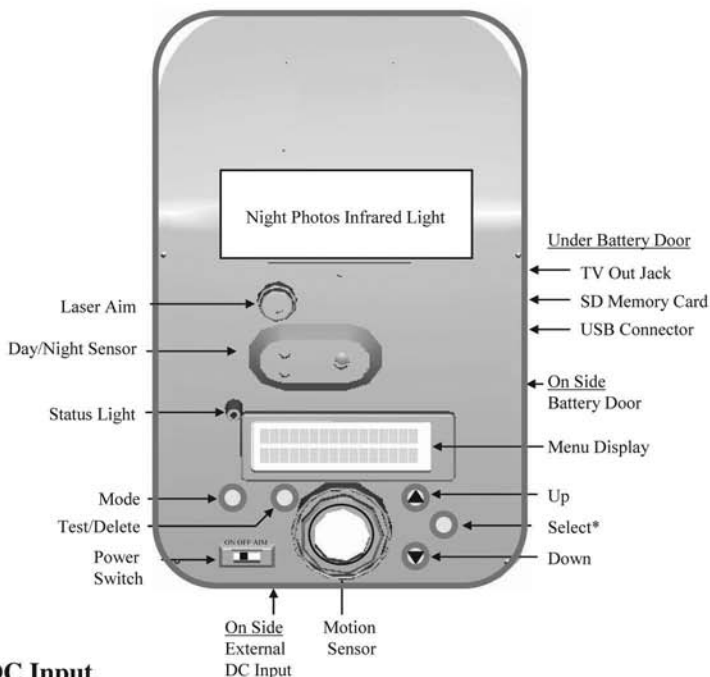

Instructions for I40 Digital Game Camera

THANK YOU for your purchase of the Model I40 Digital Game Camera. Please read this booklet before using the unit. If you should have any questions about this product or any other Moultrie product, please contact us using the information on the back of this sheet. To help us to better serve you, please complete and mail the enclosed Registration Card or you can register online at www.moultriefeeders.com

I GAME CAMERA OVERVIEW



External DC Input

Accepts optional Moultrie power pack to extend battery life in the field. Refer to www.moultriefeeders.com for more information.

TV Out Jack

View still pictures and videos on your TV by connecting provided cable

SD Memory Card

Accepts up to a 4GB SD Card for additional storage capabilities

USB Connector

Download still pictures and video onto your computer by connecting provided cable

Laser Aim

Laser can be enabled to precisely aim your camera during setup

*This button becomes the shutter button when lid is closed and camera is in Handheld mode

II QUICK START INSTRUCTIONS

- 1** Remove two thumb screws and slide Accessory Door to open as shown. Remove internal thumb screw and open hinged Battery Door
- 2** Install 6 Alkaline D size batteries with polarities as indicated on the top of the Battery Door. Re-install Battery and Accessory Door.
- 3** Secure Camera to tree or pole using strap loops on back and provided Strap.
- 4** Turn Camera on by sliding switch to ON position and then set the time/date using SELECT, UP and DOWN buttons.
- 5** Press MODE button until AUTO is displayed

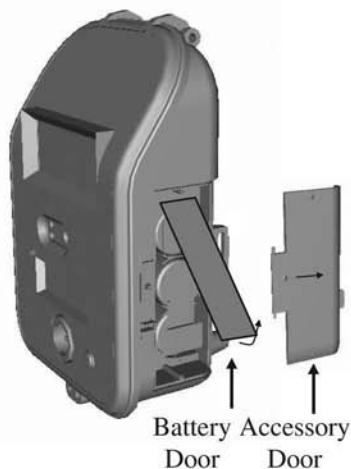

Your Camera will now automatically take pictures whenever an animal is detected in range - based on the default settings below

III DEFAULT SETTINGS

Attribute	Default Setting
Capture Mode	Still Pictures
Image quality	Standard 640x480
Multi-shot	1 Picture Per Detection
Delay Between Pictures	1 Minute

IV CHANGING DEFAULT SETTINGS

The UP/DOWN buttons allow you to scroll through available camera settings. Press the SELECT button to highlight the current setting (setting begins flashing). Press the UP or DOWN button to scroll through the available options (ex. 1 minute delay, 5 minute delay, 10 minute delay, etc.). Press the SELECT button again confirms your selection (setting stops flashing). Pressing the UP/DOWN buttons scrolls to the next camera setting.

- **Set Time and Date** – on the SETUP DATE/TIME screen, press the SELECT button to select the Month and use the UP/DOWN buttons to modify. Press the SELECT again to select the Day, etc. The Time and Date is retained between battery changes. Time is not automatically adjusted for daylight savings.

SETUP DATE/TIME
09/01/07 12:00PM

- **Info Strip** - When the Info Strip is turned ON, the information strip, as described in the Advanced Setup section of this manual, is printed on the photos. When the Info Strip is turned OFF, the photo contains no information strip.

INFO STRIP
ON

- **IR Aim** – The IR Aim function can be turned ON to test the aim. With IR Aim ON, the light on the front of the camera will illuminate each time the camera detects presence; however, a picture will not be taken. **WARNING – IR AIM MUST BE OFF IN ORDER FOR THE CAMERA TO TAKE PICTURES.**

IR AIM TEST
OFF

- **Remote Control** (default Off) - The I 40 camera has the ability to add a remote control as an option. If you did not purchase a remote control accessory with your camera, you should leave the default setting in the “off” position. The remote accessory can be purchased at most sporting goods retailers that stock Moultrie products. For more information about add on accessories for your camera, you can visit our website at www.moultriefeeders.com.

REMOTE CONTROL
OFF

- **Update Software** – Your camera allows for future software upgrades. For details regarding upgrades and instructions, go to www.moultriefeeders.com.

UPDATE LEVEL1 SW
NO L1_XXXXXX

UPDATE LEVEL2 SW
NO L2_XXXXXX

IV CHANGING DEFAULT SETTINGS (cont.)

→ **Temperature** (default Fahrenheit) – the temperature is printed on the photo and can be in degrees Fahrenheit or Celsius. To change the temperature units, press the SELECT button on the TEMPERATURE screen and the UP or DOWN button to change to the desired units.

TEMPERATURE
deg C

→ **Camera ID** – the Camera ID is printed on the photos and provides a point of reference when multiple cameras are used. To change the Camera ID, press the SELECT button on the CAMERA ID screen to modify the first character. Press the UP or DOWN button to select the desired character (A to Z, 0 to 9, dash or space). Press SELECT again to sequence through all the characters.

CAMERA ID
000000000

→ **Image Delay** (default setting 1 minute) – The image delay determines the number of minutes between pictures when an animal is detected and remains in range. To change the delay, press the SELECT button on the IMAGE DELAY screen to edit the setting and the UP or DOWN button to change to the desired setting.

IMAGE DELAY
1 MIN

→ **Multi Image** (default setting 1-shot) – When the Game Camera is configured for STILL in the Capture Mode screen above, the camera can take 1, 2, or 3 pictures each time an animal is detected. There is an approximate 13 second delay between pictures based on battery strength. To change the number of pictures taken, press the SELECT button on the MULTI IMAGE screen to edit the setting and the UP or DOWN button to change to the desired setting.

MULTI IMAGE
1-SHOT

→ **Video Length** (default setting 15 seconds) – When the Game Camera is configured for VIDEO in the Capture Mode screen above, the camera will record video for a designated amount of time each time an animal is detected. To change the amount of time recorded, press the SELECT button on the VIDEO LENGTH screen to edit the setting and the UP or DOWN button to change to the desired setting (5, 15 or 30 seconds). The default video length is 5 seconds at night.

VIDEO LENGTH
15 sec

IV CHANGING DEFAULT SETTINGS (cont.)

- **Image Quality** (default standard) – The higher the quality of the photo/image the more memory it consumes. However, higher quality images have higher resolution which results in clearer images – especially when zooming in. There are three photo/image quality settings – LOW, HIGH and ENHANCED. Press the SELECT button on the IMAGE QUALITY screen to edit the setting and the UP or DOWN button to change to the desired setting. Refer to SPECIFICATIONS section of this document for details on number of images stored based on Image Quality.

IMAGE QUALITY
LOW

- **Capture Mode** (default Still) – the Game Camera is able to take still photos or videos. Press the SELECT button on the CAPTURE MODE screen to edit the settings and the UP or DOWN button to change to the desired setting. There are two video settings – HIGH-RES VIDEO or LOW-RES VIDEO. The LOW-RES setting allows more video to be stored in memory, but the quality of the recording is less than HIGH-RES. Refer to SPECIFICATIONS section of this document for details on number of minutes stored.

CAPTURE MODE
STILL

- **Restore Default Settings** (default No) – to restore all the settings back to the factory default, press the SELECT button on the DEFAULT SETTINGS screen. Press the UP or DOWN button to change the value to Yes and SELECT to activate.

SET TO DEFAULT
NO

- **Erase Images** (default No) – to remove all the images from the internal memory or on the SD card if installed, press SELECT button on the ERASE IMAGES screen. Press the UP or DOWN button to change the value to Yes and SELECT to activate.

ERASE ALL IMAGES
NO

This device complies with part 15 of the FCC Rules. Operation is subject to the following two conditions: (1) This device may not cause harmful interference, and (2) this device must accept any interference received, including interference that may cause undesired operation.

This equipment has been tested and found to comply with the limits for a Class B digital device, pursuant to part 15 of the FCC Rules. These limits are designed to provide reasonable protection against harmful interference in a residential installation. This equipment generates, uses and can radiate radio frequency energy and, if not installed and used in accordance with the instructions, may cause harmful interference to radio communications. However, there is no guarantee that interference will not occur in a particular installation. If this equipment does cause harmful interference to radio or television reception, which can be determined by turning the equipment off and on, the user is encouraged to try to correct the interference by one or more of the following measures:

- > Reorient or relocate the receiving antenna.
- > Increase the separation between the equipment and receiver.
- > Connect the equipment into an outlet on a circuit different from that to which the receiver is connected.
- > Consult the dealer or an experienced radio/TV technician for help

Changes or modifications not expressly approved in this manual could void your authority to operate this equipment.

V MODES OF OPERATION

Your Game Camera has multiple modes of operation that may be enabled by navigating to the appropriate screens via the software menu system. The camera powers-up in SETUP mode which is defined on the previous pages of this manual. Each time the MODE button is pressed, the software advances to the next mode. The sequence is: SETUP -> AUTO -> HANDHELD (then back to SETUP and repeat).

1 SETUP MODE

Enables you to customize the operation of your camera - refer to the CHANGING DEFAULT SETTINGS section of this manual. The camera automatically goes into the AUTO mode after 4 minutes of inactivity.

SETUP DATE/TIME
09/01/07 12:00PM

2 AUTO MODE

The camera should be in AUTO mode when using it to take pictures or videos based on the detection of an animal. In AUTO mode the display shows the number of pictures taken / total pictures and the battery strength (B:94%). When AUTO mode is first entered the green status light LED will flash for 30 seconds; during this period the camera will not take a picture. When the flashing of the status light stops the camera is armed and ready.

AUTO P:0000/0331
DLY: 00:05 B:95%

3 HANDHELD

Handheld mode enables your game camera to be used like a regular digital camera by pressing the shutter button to take the picture. In the HANDHELD mode * indicates capturing a video clip or charging flash, RDY = Camera Ready, and V = camera is capturing video.

HANDHELD B:94%
*RDY P:0001/0331

1 MOUNTING CAMERA

Thread provided Mounting Strap through the Eyelets on the back of the camera and secure to tree or pole approximately 36" from the ground.

Your camera is equipped with a Tripod Receptacle so you have additional ways in which to mount your camera in the field. For more information on Moultrie's camera mounting systems, please visit our website at www.moultriefeeders.com

Up / Down Angle Adjustment Knob

Eyelet

Mounting Strap

Tripod Receptacle



2 AIMING CAMERA

The Laser Aim feature will illuminate a laser beam in the center of the focal range of the camera. The "red dot" will allow you to verify that the camera is aimed at your desired location. Turn the Power Switch to the AIM position to illuminate the Laser. Adjust the Camera angle using the Up/Down Angle Adjustment Knob on back as shown above. Turn knob clockwise to angle the camera downward and counter clockwise to angle it upward.

Caution: Looking into the laser beam may be hazardous to the eyes. Do not stare into the laser beam or direct it towards other people unnecessarily.

Caution: Use of controls or adjustments or performance of procedures other than those specified herein may result in hazardous radiation exposure.

Class II Laser Product

Wavelength: 650 nm

Maximum Output: < 1 mW

Product complies with the applicable requirements of 21 CFR 1040.10 and 1040.11



Warning and Aperture label located next to laser aperture



ID/Certification Label located on inside of front cover

3 VIEWING PICTURES - TV OUT

There are two methods available to you for viewing pictures - TV Out Jack or your computer.

1. To enter TV Out Mode, turn on the camera and place in the SETUP mode.
2. Plug RCA jack on provided TV Adapter Cable into a VIDEO IN port on a TV or VCR.
3. Plug other end of TV Adapter Cable into the TV Out Jack. Pictures are now presented on the TV.
4. To view pictures use the UP or DOWN button to sequence to the next/previous captured picture or video clip. The camera's menu display shows the picture number being viewed.
5. To delete current picture or video, press the "TEST/DELETE" button.
6. To exit TV mode, unplug the TV Adapter Cable from the TV Out Jack and TV or VCR.

4 VIEWING PICTURES - USB

1. To enter USB mode, turn on camera and place in SETUP mode.
2. Plug provided USB cable into the USB port on your Windows XP/ME/2000 computer.
3. Plug other end of USB cable into the camera's USB port.
4. To access JPG pictures and AVI movie files, navigate to "My Computer" and double click the "Moultrie CAM" folder.
5. To exit USB mode, follow Window's instructions for properly disconnecting a removable drive and then unplug the USB cable from the computer and the camera.

Note: If the camera is placed in AUTO or HANDHELD modes the USB connection with the computer will not be successful.

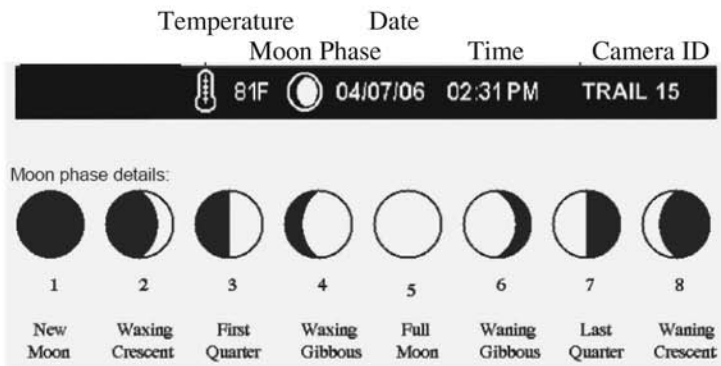
5 INFORMATION ON PICTURE

6 SD CARD

Before installing an optional SD Memory Expansion Card, the internal memory of the camera must be cleared by erasing all the internal pictures. To erase the internal memory, go to **SETUP -> ERASE ALL IMAGES**, Press the **SELECT** button, Press the **UP** button to change to **YES** and then press **SETUP** again to erase the images.

Once the internal memory has been erased, turn camera **OFF**, insert the SD Card in the slot as shown below and then turn the camera **ON**.



SD Card Slot

VII GAME CAMERA SPECIFICATIONS

Attribute	Specification
Resolution	4.0 MP
Built-in storage Memory	32 MB
Resolutions	
LOW	VGA-640 x 480
HIGH	2M-1648 x 1236
ENHANCED	4M- 2400 x 1800
LOW-RES VIDEO	320 x 240
HIGH-RES VIDEO	640 x 480
Approximate Pictures / Videos (time) stored internal memory	
LOW	341
HIGH	56
ENHANCED	32
LOW-RES VIDEO	4 min 50 sec
HIGH-RES VIDEO	1 min 10 sec
Approximate Pictures / Videos (time) stored 256 MB SD card	
LOW	2841
HIGH	469
ENHANCED	269
LOW-RES VIDEO	40 min 10 sec
HIGH-RES VIDEO	10 min 30 sec
Optional SD Memory Card	4 GB Max
Optical Field of View	52 degrees
Batteries	6 Alkaline D-cell
Approximate Detection Range	40 +/- 5 feet



Our Service Department will gladly answer any questions you have. Call 205-664-6700 or 800-653-3334, Monday - Friday, 8:00 AM to 5:00 PM CST.
www.moultriefeeders.com