



Doosan Infracore
Construction Equipment

DL400

Engine Power : SAE J1995, gross 280 HP (209kW)@ 2,000 rpm

Operational Weight : 49,603 lb (22,500 kg) - STD.

Bucket capacity(SAE) : 4.8 ~ 6.1 cu.yd (3.7~ 4.7 m³)



Wheel loader : DOOSAN DL400

A Powerful Wheel loader with Novel Features



DL 400

The new DL400 wheel loader has all the advantages of the previous loaders. This logical new step provides real added value to the operator.



The key phrase used during the development of the DL400 was "giving optimal value to the end user". This translates, in concrete terms, into:



Increased production due to the use of a new generation "Common Rail" engine and the excellent synchronisation of the drive train with the hydraulics system.

Improved ergonomics, increased comfort and excellent all round visibility ensuring safe and pleasant working conditions.

Improved reliability through the use of higher performance new materials, the development of new computer-assisted structural design techniques and by intensive and systematic test programs. All of these combine to increase the life of vital components and reduce operating costs.

Reduced maintenance increases the availability of the loader and reduces operating costs.

PERFORMANCE

DL400 features an intelligent, load-sensing hydraulic system. Two variable piston pumps provide the exact flow and pressure required and delivers a powerful, highly effective force, offering superior penetration of the hardest materials. The exceptional drawbar pull at the wheels, is reinforced further by providing limited-slip differentials as standard equipment. The engine offers high power and torque characteristics. As a result, the hydraulic system is able to multi-function with power and speed.

Axle

Improved internal oil flow greatly reduced the temperature difference between the hub and the differential, as well as prevents premature disc wear due to overheating of the internal hub components.

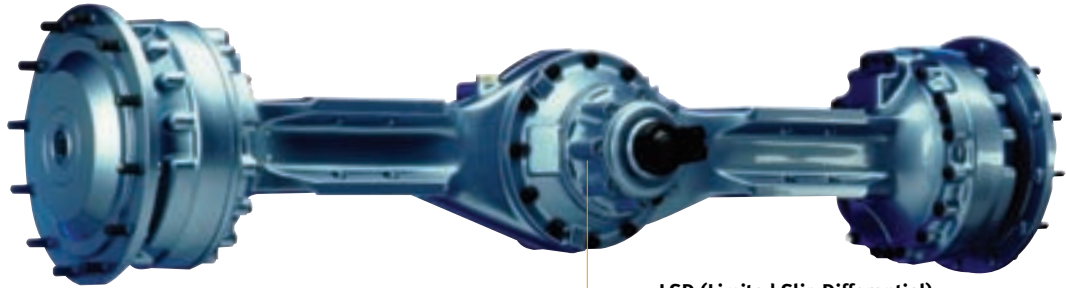

LSD (Limited Slip Differential)

The standard equipment LSD allows easy driving through soft and swampy grounds.

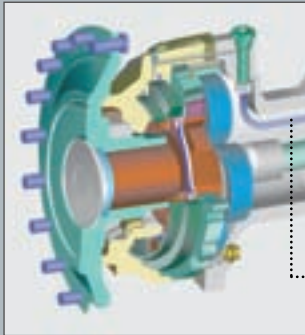

Increased Axle durability

The brake discs have been repositioned to the rear part of the reduction gear where the rotation speed is lower. As a result, the discs are exposed to lower rpm's and heat generation is reduced and the life span of the discs is greatly extended. Automatic disc clearance regulator has been intergrated into the design and the disc clearance is maintained at the optimum level at all times as the discs wear out. This prevents any lag in brake response. Another convenient feature is that brake disc wear can easily be measured without disassembling the hub.

The brake piping has been redesigned into the axle housing and is protected from damage from external shock as the machine drives over rough terrain.

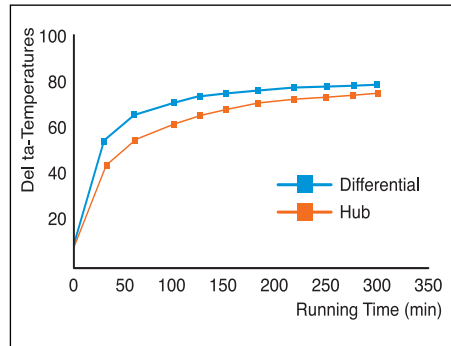

• This result may change according to test condition.

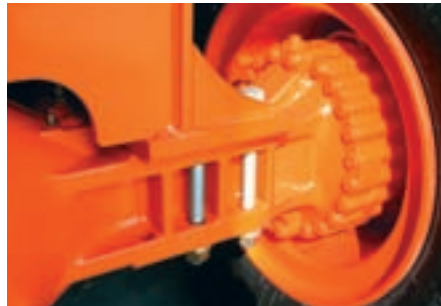

Cummins "QSL 9" Engine

The QSL 9 low emission engine combines a patented High-Pressure Common-Rail (HPCR) fuel injection system with full authority electronics for superior low-end performance with a strong torque rise.



Full Auto Transmission

The electronic powershift transmission is particularly smooth and gear ratios perfectly spaced to give optimal speed. That gives comfort at the same time that it delivers excellent traction in every working conditions. Built-in electronic controls enhance productivity and durability. The free wheel stator torque converter improves power train efficiency in load and carry operations which contributes to the improved fuel efficiency.

DL 400

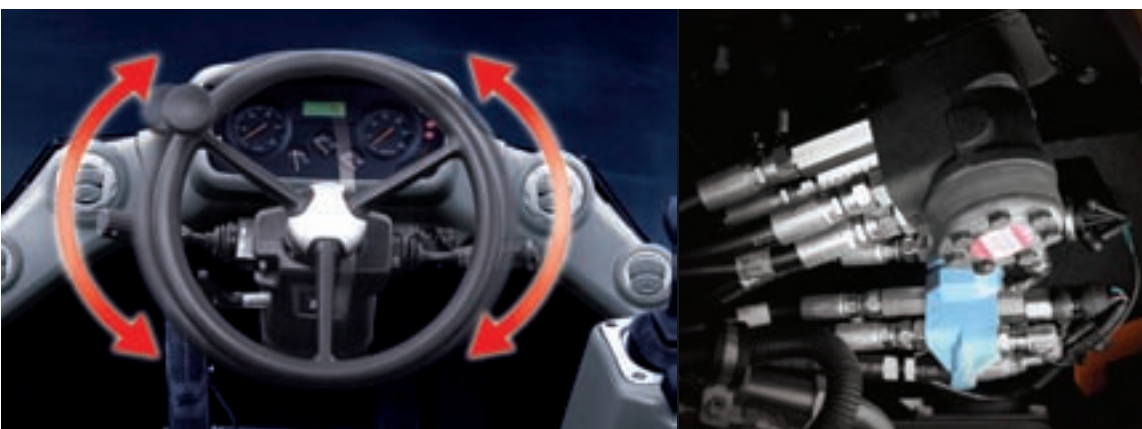

Hydraulic Power Steering

Works with a flow amplifier and priority valve. And the emergency steering system is equipped as an option to secure a safety against a malfunction of steering system during traveling.

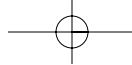

COMFORT

DL 400

From the beginning, Doosan has had great concern for machine operators. People need to work in a well-designed and comfortable environment. The work area is spacious, with several places for storage. The checking and monitoring devices are comprehensive. There is an open view of the work area. For night work, operators are provided with powerful front and rear lighting.



Noise Level

- LwA Surface Sound Power Level : 104dB(A) (ISO 6396)
- LpA Operator's Cabin noise level : 73dB(A) (ISO 6396)



The steering Column

The steering column features both tilting and telescopic functions.

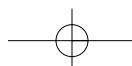

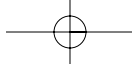

Air Conditioning & Defroster System

Double filtered air cab, air ducts are properly placed all around the cab with proportional sensitive controls and air re-circulation facility. we offer the same comfort as a passenger car.



3" Safety belt
- Retractable seat belt

Air-Suspension Seat

Now available Air-suspension seats provide more comfort and support for the operator.



Switch

The ergonomically laid out switch panel in line with the natural movements of the body allows for very convenient operation. The spare switch cut-outs allows easy installation of additional electric accessories.



Various Control Lever

The joystick installed in compliance with various needs and preferences of operators ensures more convenient work.



Central Monitor Panel

The compact central monitor panel is ergonomically designed and allows the operator to monitor the status and warning lights at a single glance.



Sunvisor & Room mirror(Std.)



Wrist rest

The tilting and telescopic wrist rest allows the operator to work more comfortably.

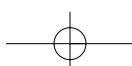

MAINTENANCE

DL 400

A liquid crystal display conveys information to the operator relative to the ZF transmission. At the same time, it reports the nature of a problem (if one exists). When servicing the loader, a specialised apparatus can be used to adjust the clutch disks to compensate for their wear. Additionally, by connecting a lap top computer, a complete transmission diagnostic can be performed.



A good accessibility at the articulation joint is essential for an easy maintenance.

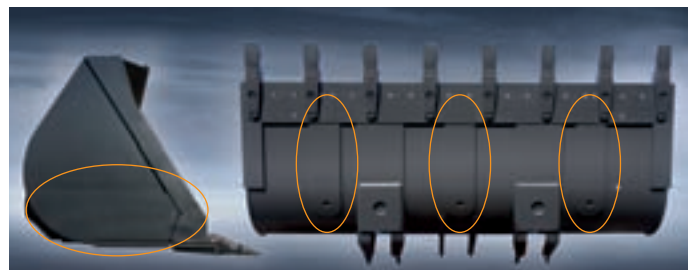

Reinforced Bucket

The lower and side panels of the bucket have been reinforced with additional plates (Std).

- Reinforcement : At both sides - 1 point each
- At lower panel - 3 point



Transmission & Engine Diagnosis

The transmission can be diagnosed using a laptop computer to interface with the diagnostic system.



Large Capacity Transmission Oil Cooler

The large capacity transmission oil cooler ensures durable and stable operation of transmission.



Remote Engine oil & Coolant Drain

Remote drain valves have been installed in an easily accessible location for convenient draining of fluids. (Coolant - upper, Engine oil - lower)



Hydraulically operated reverse fan

With electronic control of the variable speed on-demand fan, temperature levels of the engine coolant, transmission oil are constantly monitored. Controlled fan speed improves fuel efficiency, lowers noise levels and reduces radiator plugging. The hydraulic fan can be switched to reverse operation from the cabin for quickly clean out the cooling system.



Central Remote Hydraulic Check Port

The centralized remote hydraulic check ports allow main, steering, brake charge, pilot, load-sensing signal and transmission clutch pressures to be checked at a convenient central location.

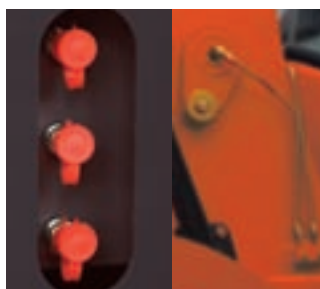

Remote Greasing Lubrication Ports

The front pins can be lubricated from the outside of the machine without crawling under the machine or in awkward positions through the lubrication ports.

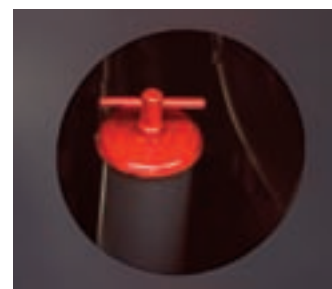

Convenient Transmission Oil Filling

The oil filler pipe is located near the articulation joint for easy access.



Propeller Shaft

A protective cover has been installed to protect the oil seal from dust, foreign objects and premature wear.



Transmission Filter

The transmission filters are within easy reach and like the rest of the machine's service components, can be checked from ground level.



Air-Cleaner Filter

The high capacity air cleaner eliminates harmful particles from the air and extends the life of the engine and replacement intervals.



Brake & Pilot Filter

The pilot filter is easy to replace and a clogged filter warning system has been added for extra protection.

Sight Gauges

Well-located, yet easily visible sight gauges for the hydraulic oil and radiator coolant allow easy daily checks while reducing the risk of contaminants entering the systems.

RELIABILITY

DL400

Every morning, when the operators commence work, they know that things will go smoothly- because Doosan has taken care of it. The product is solid. Operators know that they have significant reserves at hand and that they won't have to push the machine to its limit. The Doosan DL400 wheel loader is designed and built to last. For Doosan, 'reliable' means availability, accessibility and simplicity.

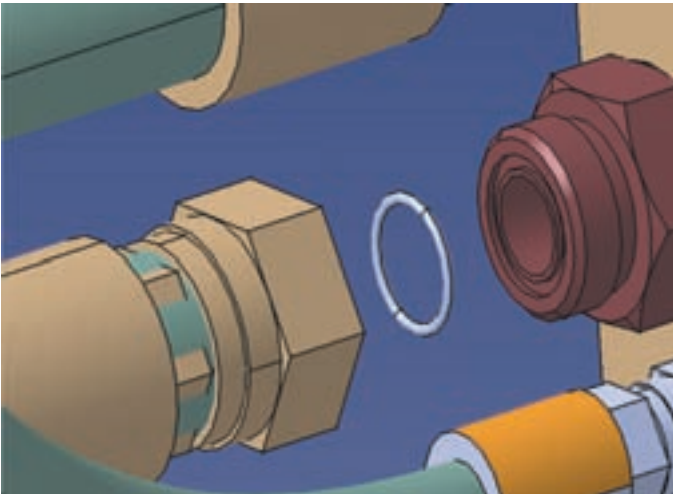

ORFS-All Ports(Even in Pilot line and Low pressure line)

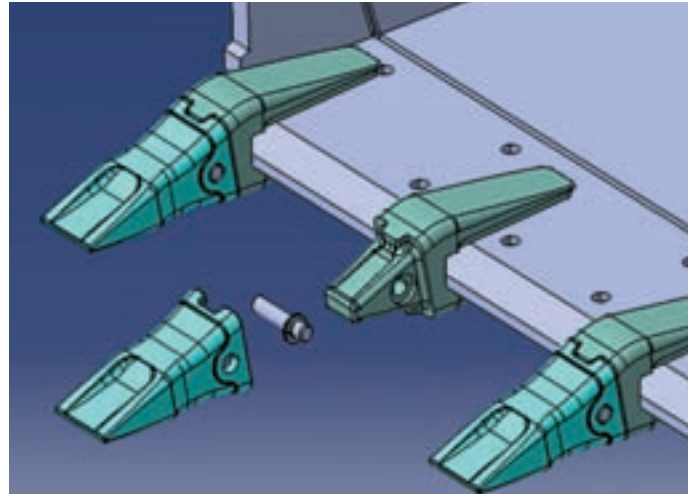

2-piece type tooth(Pin-on+Bolt-on adapter)



Covering(On pin-end) Pin & Bush Improved

- Increase Diameter
- Bronzed Bush
- Chrome-plated Pin



Radiator Grill (Steel structure)

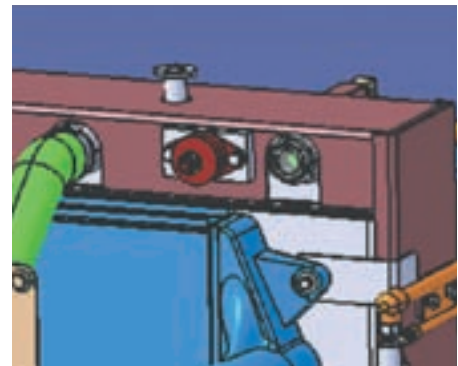

Rubber-mounting (for Radiator: Lateral 2EA / Vertical 2EA)



Fender-Edge

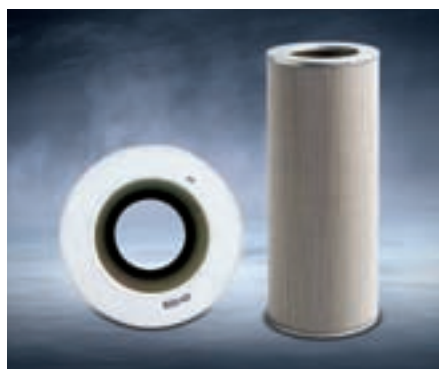

Hydraulic Oil Return Filter

The high-efficiency, large-capacity return filter manufactured with the glass-fiber media can eliminate foreign substances up to 99.5 percent to protect the costly hydraulic equipment and substantially extend the replacement cycle.

STANDARD AND OPTIONAL EQUIPMENT

* STANDARD EQUIPMENT

• Engine

- Three stage air cleaner with cyclone pre-cleaner, inner filter, And external plugging indicator as at the dashboard
- Water separator with fuel filter
- Crankcase Ventilation oiltrap system
- Preheating of induction air
- Two fuel filters
- Coolant filter
- Hydraulically driven fan with bi-direction flow for core cleaning Proportional to fluid temperature
- External drans for engine oil and coolant
- Electric driven fuel feeding pump
- Mode selector switch for the engine power (Standard / Economy mode)
- Self-diagnosis function

• Lifting and Hydraulic system

- Robust Z bar lifting system
- General purpose bucket 3.9m³ (SAE,heaped)
- Single lever joystick
- Hydraulic control valve with two sections
- Automatic boom kick out
- Automatic bucket return to dig
- Fast couplers for hydraulic check
- Variable piston and load sensing hydraulic system

• Steering system

- Load sensing steering system

• External equipments

- Lower protection plates
- Lifting hooks
- Articulation lock in the transport position
- Towing hitch
- Tools compartment
- Fender

• Electric System

- Alternator 70A / 24 V
- Working lights : 2 at the front and 4 at the rear (6 x 70W)
- Driving lights: low and high beams
- Tail indicators, stop, reversing lights
- Reversing alarm

• Drive line and Brake system

- Gear box which can be declutched when braking
- Gear box with diagnosis and monitoring indicator, and electronic plug for a fast adjustment
- Mode selector switch for the transmission (Manual / Auto 1<->4 / Auto 2<->4)
- Starting safety system
- Kickdown and travelling direction selection: lever at left of the steering wheel or on the joystick
- Limited slip differential on front and rear axles
- Dual brake circuits with accumulator
- Tire 26.5 - 25 - 20PR (L3)
- Dual service brake pedals
- Secondary brake system
- Parking brake on the transmission, electric-hydraulic

• Cab

- Air-conditioning / heating with recirculation function
- Double Filtered air cab
- Air Suspended seat with safety belt(2")
- Adjustable steering column
- Compartment for cans
- Floor mat
- Tinted glasses
- Left sliding window
- Front and rear wiper
- Front and rear washers
- Sun visor
- Interior cab light
- Interior room mirror (2)
- Exterior rear view mirrors (2)
- Machine monitoring (condition, control & maintenance indicators in front of the driver by dials, gauges and lamps)
- Main switches in front of the driver (Starter & hazard switches)
- Switches for the general functions in the right console
- Electrical horn
- Cigarette lighter
- Cassette radio AM / FM
- 12 Volt socket
- Cup holder
- Compartment for Shoes
- Glass antenna
- Heatwire in side mirror
- ROPS Cabin(Rollover Protective Structure): ROPS Meets The Following Criteria
- SAE 1040 , ISO 3471
- FOPS Cabin(Falling Objects Protective Structure): FOPS Meets The Following Criteria - SAE J 231, ISO 3449
- Digital clock
- Coat hook

* OPTIONAL EQUIPMENT

Some of these optional equipments may be standard in some markets. Some of these optional equipments cannot be available on some markets. You must check with the local Doosan dealer to know about the availability or to release the adaptation following the needs of the application.

• Ground Engaging Tools

- Various types of buckets, fork palette, timber grapples and accessories

• Tyres

- L3, L4, L5 following various types of manufacturers

• Hydraulic

- Hydraulic control valve with 3 sections
- FNR mono lever with 3rd function lever for third section
- Two hydraulic levers for 2 sections with FNR function
- Three hydraulic levers for 3 sections with FNR function
- Load isolation system (LIS)
- Emergency steering pump driven by electric motor
- Hydraulically driven fan with adjustable speed proportional to fluid temperature and bi-direction flow for core cleaning

• Electric system

- Rotating beacon
- Additional lighting

• Cab

- Rear Camera (CCTV) and monitor
- MP3 / CD player
- Air suspension seat with 3" belt

• Various

- Additional counterweight
- Tool Kit
- Mudguard

• External equipments

- Full fender with rubber protector
- Wheel chocks

TECHNICAL SPECIFICATIONS

* ENGINE

The high performance Cummins QSL 9 combined a 6 cylinder in-line, high-pressure common-rail (HPCR) fuel injection system with electronically controlled direct injection and turbo charged air to air intercooler offers low fuel consumption and emission.
(Phase I Area: Doosan QSL 9 Engine)

-GROSS SAE J1995

Rated Power :

209 kW @ 2,000rpm
280 HP @ 2,000rpm
284 ps @ 2,000rpm

Max. Power :

314 HP @1,700 rpm

Max Torque :

148 kgf.m @ 1,400rpm
1,451 Nm @ 1,400rpm
1,072 lbf.ft @ 1,400rpm

Displacement :

8,900cc (543cu.in)

Bore x stroke :

∅114x144.5mm(4.5"x 5.7")mm

Wet replaceable cylinder liner

3 stages Air cleaner including a very efficient pre-cleaner, main and safety elements.

Hydraulically driven puller type fan with possibility of adjustment.

Battery :

System voltage : 24V
Quantity : 12Vx2
Capacity(AMP) : 150Ah

Starter power :

24Vx6.6kW

Alternator output :

70A
24V

* AXLES

The front and rear axles with planetary hub reductions are built on the base of very reputed components.

Fitted as standard, the front and rear limited slip differentials, ensure the traction is optimal in all circumstances.

Maker and model :

ZF MT-L3000 Series

LSD Differential

Front (30%) / Rear (45%)

Oscillation angle :

+/- 12° Rear 24°

Brake :

Dual circuit multi-plate wet discs.
Hydraulic actuation with pump and accumulator.

The sintered metal brake discs extended discs service intervals : increased three times

A spring applied and hydraulically released parking brake is mounted on the transmission shaft.

* TRANSMISSION

"Full Power Shift" transmission. It can be used in manual or automatic modes.

This transmission is based on components having excellent worldwide reputations. It is equipped with a modulation system allowing soft gear shifting and inversion of travel direction. Safety devices also protect the transmission of bad operations.

The gear and direction shifting is operated by a single lever to the left of the steering wheel. A travel direction control is also mounted on the hydraulic joystick.

With a special electronic device, the transmission can be tested and adjusted easily for optimum performance and efficiently.

The transmission can be de-clutched by the operation of brake pedal to increase the power available to the hydraulic pumps.

A safety device prevents the starting of the engine when not in neutral.

Torque converter :

Type : Single stage, one phase, three elements
Stall ratio : 2.104

Gear box :

Maker and model

ZF 4 WG 210

Speed Forward/Rearward :

(Tire 26.5 - 25 - 20PR - L3)

1	6.5 / 6.5 km/h (4.0 / 4.0 mph)
2	12.4 / 12.4 km/h (7.7 / 7.7 mph)
3	18.5 / 28 km/h (11.5 / 17.4 mph)
4	38 km/h (23.6 mph)

DL 400

* HYDRAULIC SYSTEM

Two load-sensing axial piston pumps with variable displacement.

Main control valve of double acting 2-spool is controlled by standard single lever.

Automatic boom kick out and bucket return to dig. Is standard.

All of hydraulic lines are equipped with special seals (ORFS)

Max flow main:

(With steering)

190 l / min (50.2 / min)

(Without steering)

380 l / min (100.4 g / min)

Working Pressure:

250 bars

Pressure of the pilot circuit:

30 bars

Filtration capacity on the return line:

10 microns

Loading cycles time:

Lifting speed (loaded) :

6.0 seconds

Dumping speed (loaded) :

1.4 seconds

Lowering speed (empty) :

3.0 seconds

* OPERATOR' CAB

The modular cab allows excellent visibility in all directions. The optimal ventilation is obtained by numerous ventilation outlets. Touch buttons control the air re-circulation air conditioning and heating systems. The air of the cab is filtered.

All necessary information for the operator are centralized in front of him.

The main functions are actuated via switches located on a console at the right of the operator.

Generous storage places are well located. The cab, mounted on viscous element and equipped with an air suspended seat, offers a better comfort for the operator.

Access door: 1

Emergency exits: 2

The cab conforms ROPS ISO 3471 and FOPS : ISO 3449

Guaranteed external noise level Lwa:

(following 2000 / 14 / EC) 104 dB (A)

* STEERING

The steering system is a load sensing type with a flow amplifier and a priority valve.

Steering angle :

40°

Oil flow :

190 l / min (50.2 g / min) @ 2000 rpm, rated

Working pressure :

185 bars

Steering cylinders (2) :

bore x stroke : 100 x 450 mm (3.9" x 1' 6")

Emergency steering system with hydraulic pump driven by electric motor.

* LIFTING SYSTEM

The lifting system with two cylinders and Z configuration is designed for the toughest jobs. The breakout force (22 ton with a 3.9m³ bucket) is very important and the bucket movements are fast.

The bucket angles are well kept in good positions on all the range of bucket movement.

Lifting cylinders (2)

bore x stroke : 160 x 928 mm (6.2" x 3'1")

Bucket cylinders (1)

bore x stroke : 180 x 600 mm (0.7" x 2')

* MAINTENANCE

Maintenance is easy due to excellent access.

The transmission is electronically controlled. An error coding system allows easy diagnosis of the systems and proper intervention.

Engine (oil) : 25 l (6.6 gal)

Radiator (cooling liquid) : 50 l (13.2 gal)

Fuel : 365 l (96.4 gal)

Hydraulic oil : 265 l (70 gal)

Gear box and torque converter : 54 l (14.3 gal)

Front axle : 45 l (11.9 gal)

Rear axle : 42 l (11.1 gal)

OPERATIONAL DATA

Bucket type		General purpose						Light material		
Configuration	Unit	Teeth	Teeth (std.)	Teeth	Bolt-on edge	Bolt-on edge	Teeth & segments	Teeth	Teeth	Bolt-on edge
Capacity heaped ISO/SAE	m ³	3.7	3.9	3.9	3.9	4.1	4.1	3.5	4.5	4.7
	yd ³	4.8	5.1	5.1	5.1	5.4	5.4	4.6	5.9	6.1
Tooth type		Adapter tooth	Adapter tooth	Integrated tooth			Adapter tooth	Adapter tooth	Adapter tooth	
Bucket width	mm	3,040	3,200	3,200	3,040	3,200	3,200	3,231	3,354	3,354
	ft.in	9'12"	10'6"	10'6"	9'12"	10'6"	10'6"	10'7"	11'	11'
Breakout force	kN	220	220	220	220	220	220	210	190	190
	lbf	49,458	49,458	49,458	49,458	49,458	49,458	47,210	42,714	42,714
Static tipping load (straight)	kg	18,800	18,900	18,900	18,800	19,100	19,100	19,000	19,000	19,200
	lb	41,447	41,667	41,667	41,447	42,108	42,108	41,888	41,888	42,329
Static tipping load (40°)	kg	16,400	16,500	16,500	16,400	16,670	16,670	16,580	16,580	16,760
	lb	36,156	36,376	36,376	36,156	36,751	36,751	36,553	36,553	36,949
Dump height (at 45°) ¹⁾	mm	2,975	2,975	2,984	3,090	3,090	2,975	2,901	2,819	2,958
	ft.in	9'9"	9'9"	9'9"	10'2"	10'2"	9'9"	9'6"	9'3"	9'8"
Dump reach (at 45°) ¹⁾	mm	1,370	1,370	1,370	1,263	1,263	1,370	1,459	1,537	1,392
	ft.in	4'6"	4'6"	4'6"	4'6"	4'6"	4'6"	4'6"	4'6"	4'6"
Digging depth	mm	130	130	130	130	130	130	130	130	130
	ft.in	5"	5"	5"	5"	5"	5"	5"	5"	5"
Height at bucket pivot point	mm	4,350	4,350	4,350	4,350	4,350	4,350	4,350	4,350	4,350
	ft.in	14'3"	14'3"	14'3"	14'3"	14'3"	14'3"	14'3"	14'3"	14'3"
Max. angle at carry position	α	°	46	46	46	46	46	46	46	46
Max. angle at fully raised	β	°	59	59	59	59	59	59	59	59
External radius at tire side	mm	6,350	6,350	6,350	6,350	6,350	6,350	6,350	6,350	6,350
	ft.in	20'10"	20'10"	20'10"	20'10"	20'10"	20'10"	20'10"	20'10"	20'10"
External radius at bucket edge	mm	6,885	6,955	6,940	6,870	6,940	6,955	6,900	7,080	7,060
	ft.in	22'7"	22'10"	22'9"	22'6"	22'9"	23'	22'8"	23'3"	23'2"
Wheel basis	mm	3,500	3,500	3,500	3,500	3,500	3,500	3,500	3,500	3,500
	ft.in	11'6"	11'6"	11'6"	11'6"	11'6"	11'6"	11'6"	11'6"	11'6"
Width at tyres	mm	2,985	2,985	2,985	2,985	2,985	2,985	2,985	2,985	2,985
	ft.in	9'10"	9'10"	9'10"	9'10"	9'10"	9'10"	9'10"	9'10"	9'10"
Tread	mm	2,300	2,300	2,300	2,300	2,300	2,300	2,300	2,300	2,300
	ft.in	7'7"	7'7"	7'7"	7'7"	7'7"	7'7"	7'7"	7'7"	7'7"
Ground clearance	mm	510	510	510	510	510	510	510	510	510
	ft.in	1'8"	1'9"	1'8"	1'8"	1'8"	1'8"	1'8"	1'8"	1'8"
Overall length	mm	8,760	8,710	8,710	8,635	8,635	8,760	8,900	9,020	8,820
	ft.in	28'9"	28'4"	28'7"	28'4"	28'4"	28'9"	29'2"	29'7"	28'11"
Overall height	m	3,522	3,522	3,522	3,522	3,522	3,522	3,522	3,522	3,522
	ft.in	11'7"	11'7"	11'7"	11'7"	11'7"	11'7"	11'7"	11'7"	11'7"
Operating weight	kg	22,420	22,500	22,380	22,740	22,840	22,675	22,700	22,820	23,170
	lb	49,428	49,604	49,339	50,133	50,354	49,990	50,045	50,309	51,081

1) Measured to the tip of the bucket teeth or bolt-on edge.

2) All measurements with tyres 26.5-25-20PR(L3).

DIMENSIONS

DL 400

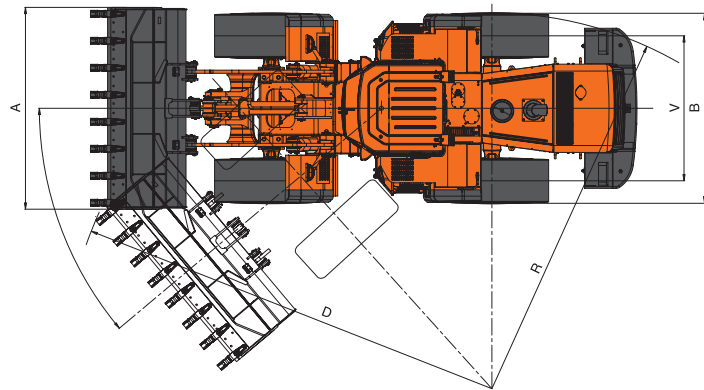
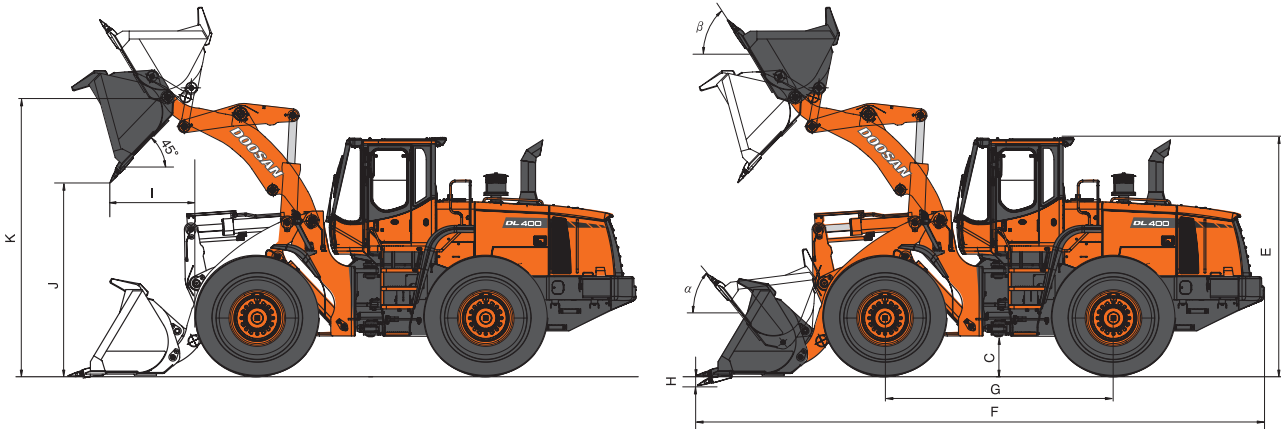

Measured to the tip of the bucket teeth or bolt on edge with tires 23.5-25-16PR(L3)

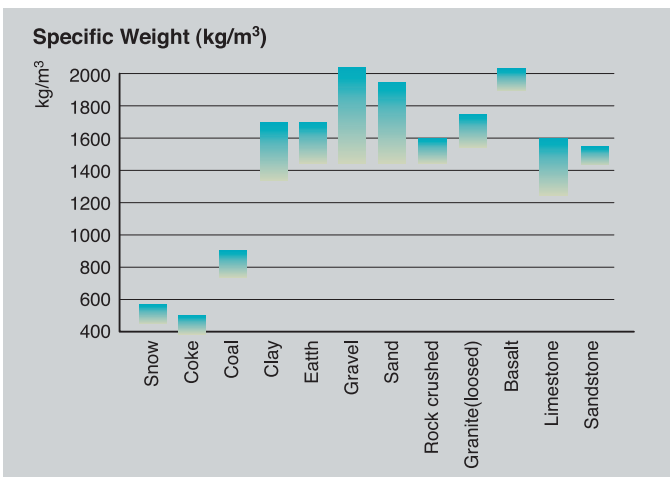

The specific weight of material largely depends on moisture rate, compacting value, percentage of various components etc... This chart is given only for information.

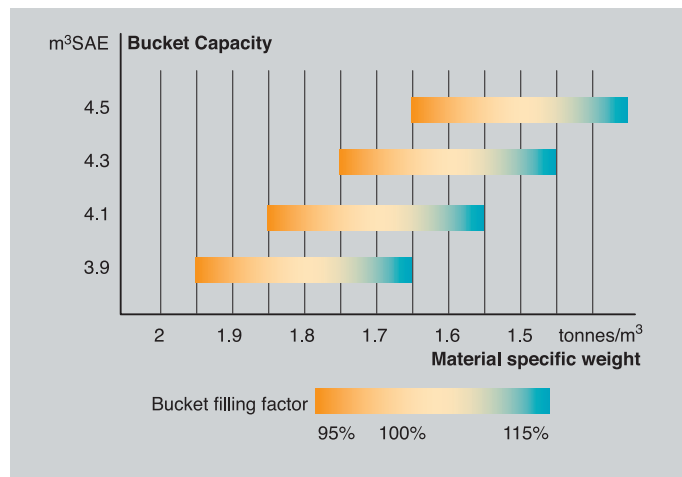

The Bucket filling factor depends also of the nature of material, the working conditions and the operator ability.

**Seoul Office :**

Doosan Tower 26TH FL. 18-12, Euljiro-6Ga,
Jung-Gu, Seoul, Korea 100-730

Tel : +82-2-3398-8114

Fax : +82-2-3398-8117

www.doosaninfracore.com

Doosan Infracore Europe S.A.

1A, Rue Achille Degrace, 7080 Frameries, Belgium
Tel : +32-65-61-3230 Fax : +32-65-67-7338

Doosan Infracore U.K., Ltd.

Doosan House, Unit 6.3, Nantgarw Park, Cardiff CF47QU, U.K.
Tel : +44-1443-84-2273 Fax : +44-1443-84-1933

Doosan Infracore Germany GmbH

Hans-Böeckler strasse 29, D-40764, Langenfeld-Fuhrkamp, Germany
Tel : +49-2173-8509-18 Fax : +49-2173-8509-45

Doosan Infracore France

ZAC de La Clef Saint Pierre - Buroplus 2 1A Avenue Jean d'Alembert
78990 Elancourt, France
Tel : +33-(0)1-30-16-21-41 Fax : +33-(0)1-30-16-21-44

Doosan Infracore America Corporation

2905 Shawnee Industrial Way, Suwanee, Georgia 30024, U. S. A
Tel : +1-770-831-2200 Fax : +1-770-831-0480

Doosan Infracore (China) Co., Ltd.

#28, Wuzhishan Road, Eco. & Tech, Development Zone, Yantai, Shandong, China
Tel : +86-535-638-2000 Fax : +86-535-638-2004

Doosan Infracore Xinjiang Machinery Co.,Ltd.

No, 178, Hetanbei Road, Wulumuqi, Xinjiang, China
Tel : +86-991-469-7217 Fax : +86-991-469-8641

Doosan Infracore Liaoning Machinery Co.,Ltd.

No.32 DongLing Road, DongLing District, ShenYang, Liaoning, China
Tel : +86-24-8841-1407 Fax : +86-24-8841-1404

Doosan Infracore South Africa (PTY)LTD.

60C Electron Road, Isando 1600, Johannesburg, South Africa
Tel : 27-11-974-2095 Fax : 27-11-974-2778

Doosan Infracore Middle East Center(Dubai)

P.O.Box 183127, Al-Serkal Building, Air Port Road,Dubai, U.A.E
Tel : +971-4-295-2781~2 Fax:+971-4-295-2783



PBP D400W000 0701

The illustrations do not necessary show the product in standard version.
All products and equipments are not available in all markets.
Materials and specifications are subjects to change without prior notice.