



**Doosan Infracore**  
Construction Equipment

# DX300LC

Engine Power : SAE J1349, net 197HP(147kW)@1,900rpm

Operational Weight : 64,594lb(29,300kg) - STD.

Bucket capacity(SAE) : 1.05 ~ 2.29 cu.yd(0.80~ 1.75 m<sup>3</sup>)



# Doosan DX300LC Hydraulic Excavator : A New Model with Novel Features



## DX300LC



The new DX300LC hydraulic excavator has all the advantages of the previous model, the Solar 300LC and now offers additional added value to the operator.

The key phrase used during the development of the DX300LC was “giving optimum value to the end user.” This translates, in concrete terms, into :



**Increased production** and improved fuel economy thanks to electronic optimization of the hydraulic system and the new generation DOOSAN engine (stage III).

**Improved ergonomics**, increased comfort and excellent all round visibility ensuring a safe and pleasant working environment.

**Improved reliability** through the use of high performance materials combined with new methods of structural stress analysis have lead to increased component life expectancy, thus reducing running costs.

**Reduced maintenance** increases the availability of the excavator and reduces running costs.

# HANDLING

The hydraulic excavator's power, durability, ease of servicing and its precise control increase its effectiveness and life expectancy. With the DX300LC, DOOSAN offers an excellent return on investment.



Multi-function color LCD monitor panel

Warning lights

Operation modes

- Mode selection
- Flow rate control
- Auto deceleration
- Display selection

Control panel  
With color LCD display

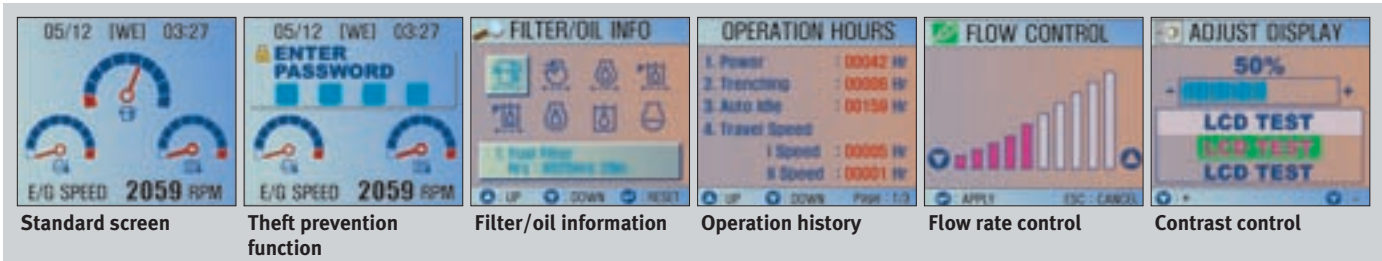

Standard screen

Theft prevention function

Filter/oil information

Operation history

Flow rate control

Contrast control

## Choice of operating modes

### Working mode

- Digging mode: for general excavation, loading, lifting...
- Trenching mode: swing priority for trench work, canal digging, embankments...

### Power mode

- Standard: uses 85% engine power for all work (optimum fuel efficiency)
- Power: uses 100% engine power for heavy work



## Control lever

Very precise control of the equipment increases versatility, safety and facilitates tricky operations requiring great precision.

Levelling operations and the movement of lifted loads in particular are made easier and safer.

The control levers have additional electrical buttons for controlling other additional equipment (for example, grabs, crushers, grippers, etc.)



Cellular phone box



12V Power socket



Cigarette lighter



Glass antenna

# COMFORT

DX300LC

**The work rate of the hydraulic excavator is directly linked to the performance of its operator. DOOSAN designed the DX300LC by putting the operator at the centre of the development goals. The result is significant ergonomic value that improves the efficiency and safety of the operator.**

More space, better visibility, air conditioning, a very comfortable seat... These are all elements that ensure that the operator can work for hours and hours in excellent conditions.



**Control panel**  
Correct positioning with clear controls makes the operator's task easier.



The high performance air conditioning provides an air flow which is adjusted and electronically controlled for the conditions. Five operating modes enable even the most demanding operator to be satisfied.



**Air suspension seat (opt)**  
Equipped with various functions of adjustment forth and back and, and lumbar support, it reduces the vibration of equipment transmitted during work in an effective way. Also for considering winter working environment, Seat warmer functions equipped.



Visibility has been improved in all directions and the size of the cab has been increased.



Appropriate storage spaces show the attention given to the operator.



**Comfortable 2-stage sliding seat**



**Control stand (Telescopic Function)**

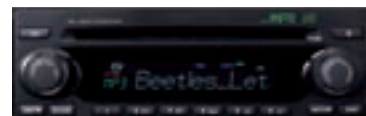

**MP3/CD Player (Opt.)**



**Audio Button**

Audio Button has been positioned in a way that the driver can turn on/off the radio, control the volume, and select a channel conveniently.

# PERFORMANCE

The performance of the DX300LC has a direct effect on its productivity. Its new "Common Rail" engine and new e-EPOS controlled hydraulic system have combined to create an unbeatable hydraulic excavator, with a cost/performance ratio that makes the DX300LC even more appealing.



"COMMON RAIL" DOOSAN DL08 ENGINE

At the heart of the hydraulic excavator is the new "Common Rail" DOOSAN DL08 engine. It is combined with the new e-EPOS electronic control system, for optimum power and fuel saving.

The new engine produces 197 hp(147 kw/200 PS) at only 1,900 rpm, and more torque, due to its careful design combined with the use of common rail injection and 4 valves per cylinder. These features help optimize combustion and minimize pollution through reduced Nox & particulate emissions.

Increased torque allows efficient use of the power of the hydraulic system.

- Faster working cycles increase productivity.
- Increased torque means the excavator is able to move more easily.
- Energy efficiency reduces fuel consumption.

DOOSAN Infracore is aware of the importance of protecting the environment. Ecology was uppermost in the minds of the research workers right from the start of the design of the new machines. The new challenge for the engineers is to combine the protection of nature with equipment performance and to this end DOOSAN has been investing heavily.

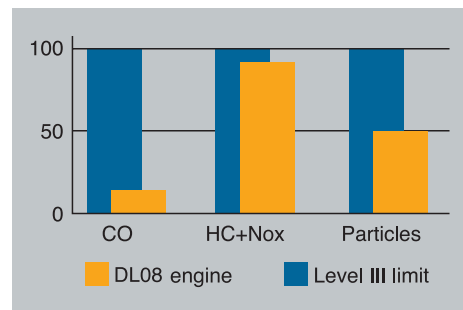
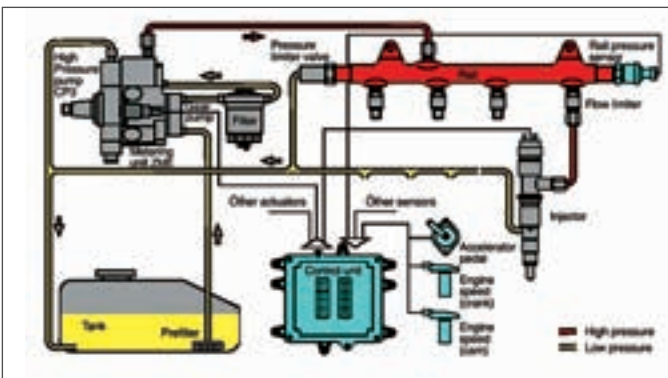

The new DOOSAN engine respects and protects the environment, limiting all types of toxic emissions.



**Hydraulic Pump**

The Main pump has a capacity of 2x247 ℓ /min reducing cycle time while a high capacity gear pump improves pilot line efficiency.



**Swing drive**

Shocks during rotation are minimized, while increased torque is available to ensure rapid cycles.

# DX300LC

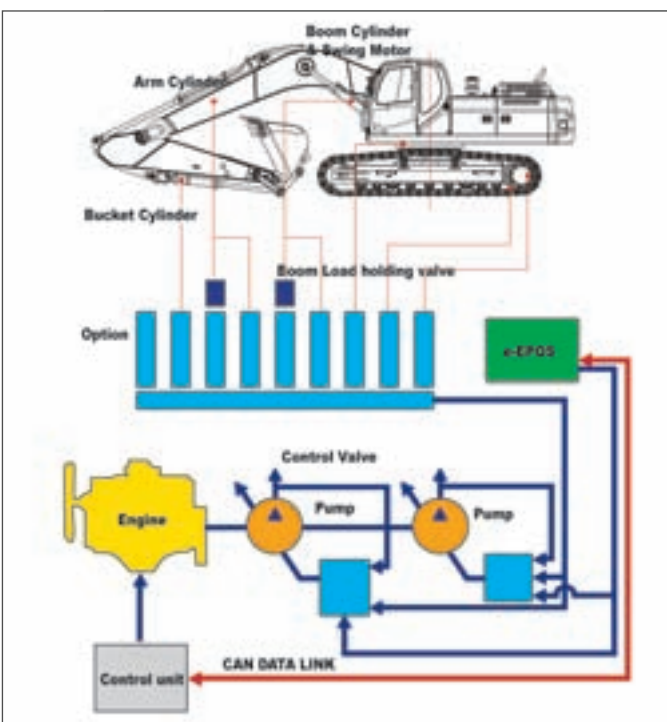

## EXCAVATOR CONTROL

### New e-EPOS system (Electronic Power Optimizing System)

The brains of the hydraulic excavator, the e-EPOS, have been improved and now can electronically link to the engine's ECU (Electronic Control Unit), through a CAN (Controller Area Network) communication link, enabling a continuous exchange of information between the engine and the hydraulic system. These units are now perfectly synchronised.

The advantages of the new e-EPOS impacts at several levels, Ease of operation and user-friendliness:

- The availability of a power mode and a normal operating mode guarantee maximum efficiency under all conditions.
- Electronic control of fuel consumption optimizes efficiency.
- The automatic deceleration mode enables fuel saving.
- Regulation and precise control of the flow rate required by the equipment are available as standard.
- A self-diagnosis function enables technical problems to be resolved quickly and efficiently.
- An operational memory provides a graphic display of the status of the machine.
- Maintenance and oil change intervals can be displayed.

# RELIABILITY

The reliability of an item of plant contributes to its overall lifetime operating costs. DOOSAN uses computer-assisted design techniques, highly durable materials and structures then test these under extreme conditions.

Durability of materials and longevity of structures are our first priorities.

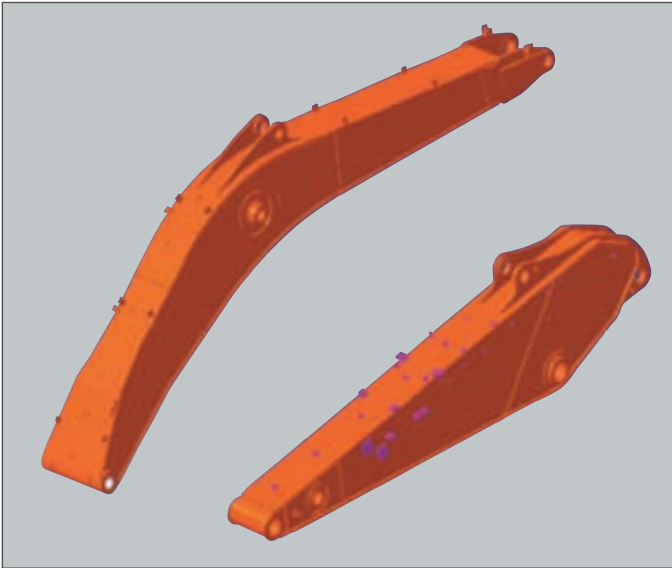

## Strengthened Boom

The Shape of the boom has been optimized by finite elements design, allowing the loads to be better distributed throughout the structure. This combined with increased material thickness means improved durability and reliability by limiting element fatigue.

## Arm Assembly

In the arm assembly greater strength has been gained by using cast elements and reinforcement around the bosses to give it an increased lifetime.

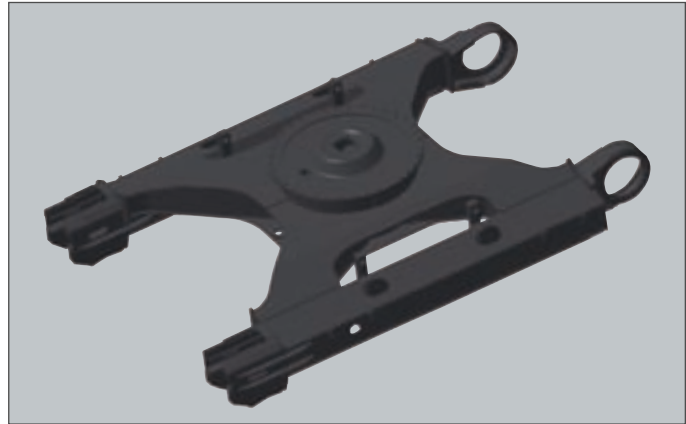

## X-chassis

The X-chassis frame section has been designed using finite element and 3-dimensional computer simulation, to ensure greater durability and optimum structural integrity. The swing gear is solid and stable.

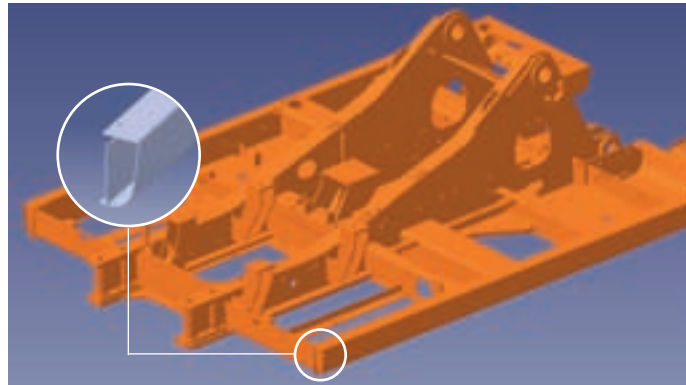

## D-type Frame

The D-type frame and chassis frame add strength and minimize distortion due to shocks.



## Bucket

Highly wear-resistant materials are used for the most susceptible elements such as the blades, teeth, rear and lateral reinforcement plates and corners of the bucket.

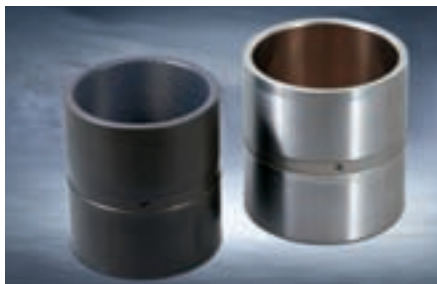

## Bushing

A highly lubricated metal is used for the boom pivot in order to increase the lifetime and extend the greasing intervals to 250 hours. A rolled bushing with very fine grooves has been added to the arm to bucket pivot, so that greasing is only required every 50 hours.



## Ultra-hard wear-resistant disc

New materials have been used in order to increase the wear resistance and to increase the service intervals. The longevity is greatly increased by the addition of wear plates on the inside and outside of the bucket lugs.



# DX300LC



**Integrated Track Spring and Idler**  
The track spring and the idler have been joined directly to achieve high durability and improved maintenance convenience.

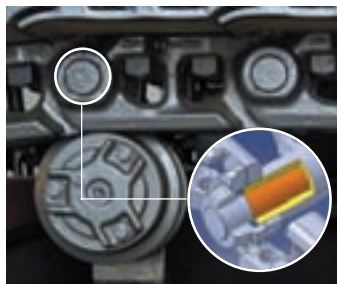

**Tracks**  
The chain is composed of self-lubricating sealed links isolated from all external contamination. The tracks are locked by mechanically bolted pins.



**Polymer shim**  
A polymer shim is added to the bucket pivot to maintain precise control over the equipment.



**Pump coupling**  
A polymer material is used to produce the coupling between the pump and engine. This material has a long life and reduces noise and vibration levels.

# MAINTENANCE

Short maintenance operations at long intervals increase the availability of the equipment on site. DOOSAN has developed the DX300LC with a view to high profitability for the user.



## Engine oil filter

The engine oil filter offers a high level of filtration allowing the oil change interval to be increased to 500 hours. It is easy to access and is positioned to avoid contaminating the surrounding environment.

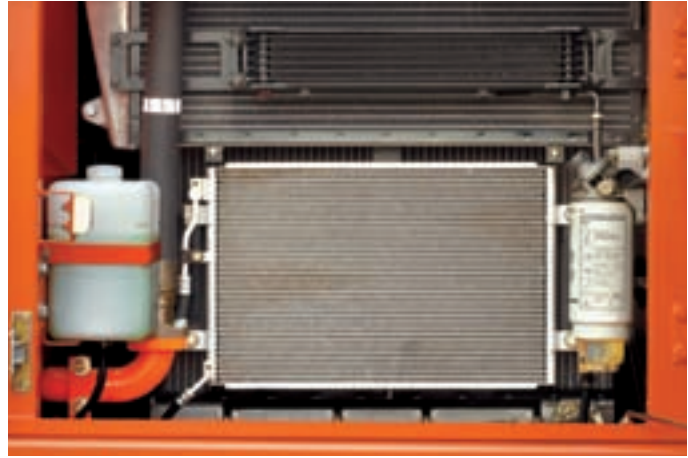

## Easy maintenance

Access to the various radiators is very easy, making cleaning easier. Access to the various parts of the engine is from the top and via side panels.

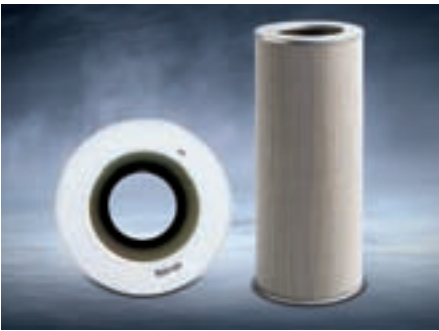

## Hydraulic oil return filter

The protection of the hydraulic system is made more effective by the use of glass fibre filter technology in the main oil return filter. This means that with more than 99.5% of foreign particles filtered out, the oil change interval is increased.



## Air cleaner

The large capacity forced air cleaner removes over 99% of airborne particles, reducing the risk of engine contamination and making the cleaning and cartridge change intervals greater.



## Fuel filter

High efficiency fuel filtration is attained by the use of multiple filters, including a fuel pre-filter fitted with a water separator that removes most moisture from the fuel.

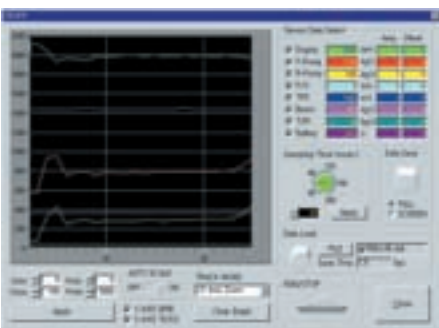

## PC Monitoring (DMS)

A PC monitoring function enables connection to the e-EPOS system, allowing various parameters to be checked during maintenance, such as pump pressures, engine rotation speed, etc. and these can be stored and printed for subsequent analysis.



## Convenient Fuse Box

The fuse box is conveniently located in a section of the storage compartment behind the operator's seat providing a clean environment and easy access.



## Centralized grease inlets for easy maintenance

The arm grease inlets are grouped for easy access.

# DX300LC



# TECHNICAL SPECIFICATIONS

## DX300LC

### \* ENGINE

#### • Model

Doosan DLo8  
"Common Rail" engine with direct fuel injection and electronic control, 4 valves per cylinder, vertical injectors, water cooled, turbo charged with air to air intercooler. The emission levels are well below the values required for phase III

#### • Number of cylinders

6

#### • Nominal flywheel power

147 kW(197HP) @ 1,900 rpm (SAE J1349, net)

#### • Max torque

93 kgf.m(911 Nm) at 1,300 rpm

#### • Piston displacement

7,640 cc (466cu.in)

#### • Bore & stroke

108 mm x 139 mm (4.3"X5.5")

#### • Starter

24 V / 6 kW

#### • Batteries

2 x 12 V / 150 Ah

#### • Air cleaner

Double element and pre-filtered Turbo with auto dust evacuation.

### \* HYDRAULIC SYSTEM

The heart of the system is the e-EPOS (Electronic Power Optimizing System). It allows the efficiency of the system to be optimized for all working conditions and minimizes fuel consumption.

The new e-EPOS is connected to the engine electronic control via a data transfer link to harmonize the operation of the engine and hydraulics.

- The hydraulic system enables independent or combined operations.
- Two travel speeds offer either increased torque or high speed tracking.
- Cross-sensing pump system for fuel savings.
- Auto deceleration system.
- Two operating modes, two power modes.
- Button control of flow in auxiliary equipment circuits.
- Computer-aided pump power control.

#### • Main pumps

2 variable displacement axial piston pumps  
max flow: 2 x 247 ℓ /min (2X65.3US gpm, 2X54.3lmp gpm)

#### • Pilot pump

Gear pump - max flow: 28.5 ℓ /min (7.5US gpm, 6.3lmp gpm)

#### • Maximum system pressure

Boom/arm/Bucket:

Normal mode: 330 kgf/cm<sup>2</sup>(324 bar)

Power mode: 350 kgf/cm<sup>2</sup>(343 bar)

Travel: 330 kgf/cm<sup>2</sup>(324 bar)

Swing: 275 kgf/cm<sup>2</sup>(270 bar)

### \* WEIGHT

Boom 6,245 mm (20'6") • Arm 3,100 mm (10'2") • Bucket SAE 1.27 m<sup>3</sup> (1.66yd<sup>3</sup>)

	Shoe width	Operating weight	Ground pressure (kgf/cm <sup>2</sup> )
Triple Grouser	(Std)600 mm (2')	29,300 kg (64,594lb)	0.56 kgf/cm <sup>2</sup> (56kpa, 8.1psi)
	700 mm (2'4")	29,900 kg (65,917lb)	0.49 kgf/cm <sup>2</sup> (48kpa, 7.0psi)
	800 mm (2'8")	30,200 kg (66,579lb)	0.43 kgf/cm <sup>2</sup> (42kpa, 6.1psi)
	850 mm (2'10")	30,500 kg (67,240lb)	0.41 kgf/cm <sup>2</sup> (40kpa, 5.8psi)
Double Grouser	(opt)600 mm (2')	29,900 kg (65,917lb)	0.49 kgf/cm <sup>2</sup> (48kpa, 7.0psi)

## \* HYDRAULIC CYLINDERS

The piston rods and cylinder bodies are made of high-strength steel. A shock absorbing mechanism is fitted in all cylinders to ensure shock-free operation and extend piston life.

Cylinders	Quantity	Bore x Rod diameter x stroke
Boom	2	140 X 95 X 1,440mm(5.5"X 3.7" X 4'9")
Arm	1	150 X 105 X 1,755mm(5.9" X 4.1" X 5'9")
Bucket	1	140 X 90 X 1,150mm(5.5" X 3.5" X 3'9")

## \* UNDERCARRIAGE

Chassis are of very robust construction, all welded structures are designed to limit stresses.

High-quality material used for durability.

Lateral chassis welded and rigidly attached to the undercarriage. Track rollers lubricated for life, idlers and sprockets fitted with floating seals.

Tracks shoes made of induction-hardened alloy with triple grousers.

Heat-treated connecting pins.

Hydraulic track adjuster with shock-absorbing tension mechanism.

### • Number of rollers and track shoes per side

Upper rollers: 2 (standard shoes)

Lower rollers: 9

Shoes: 48

Total length of track: 4,930mm (16'2")

## \* ENVIRONMENT

Noise levels comply with environmental regulations (dynamic values).

### • Sound level guarantee

104 dB(A) (2000/14/EC)

### • Cab sound level

73 dB(A) (ISO 6396)

## \* SWING MECHANISM

- An axial piston motor with two-stage planetary reduction gear is used for the swing.
- Increased swing torque reduces swing time.
- Internal induction-hardened gear.
- Internal gear and pinion immersed in lubricant bath.
- The swing brake for parking is activated by spring and released hydraulically.

**Swing speed: 0 to 9.9 rpm**

## \* DRIVE

Each track is driven by an independent axial piston motor through a planetary reduction gearbox.

Two levers with control pedals guarantee smooth travel with counter-rotation on demand.

### • Travel speed (fast/slow)

5.1/3km/h (3.1/1.9mph)

### • Maximum traction force

13,700 / 25,200 kgf (30,203/55,556lbf)

### • Maximum grade

35° / 70%

## \* REFILL CAPACITIES

### • Fuel tank

500 l (132.1US gal, 110lmp gal)

### • Cooling system (Radiator capacity)

35 l (9.2US gal, 7.7lmp gal)

### • Engine oil

36 l (9.5US gal, 7.9lmp gal)

### • Swing drive

6 l (1.6US gal, 1.3lmp gal)

### • Final drive (each)

7 l (1.8US gal, 1.5lmp gal)

### • Hydraulic system

330 l (87.2US gal, 72.6lmp gal)

### • Hydraulic tank

280 l (74US gal, 61.6lmp gal)

## \* BUCKET

Capacity		Width		Weight	Recommendation		
PCSA, heaped	CECE heaped	Without side cutters	With side cutters		2,500mm (8'2")Arm	3,100mm (10'2")Arm(Std.)	3,750mm (12'4")Arm
1.05yd <sup>3</sup> (0.80m <sup>3</sup> )	0.92yd <sup>3</sup> (0.7m <sup>3</sup> )	3'9" (962mm)	3'5" (1,037mm)	1,927lb (874kg)	A	A	A
1.37yd <sup>3</sup> (1.05m <sup>3</sup> )	1.18yd <sup>3</sup> (0.9m <sup>3</sup> )	3'10" (1,172mm)	4'1" (1,247mm)	2,207lb (1,001kg)	A	A	B
Std. 1.66yd <sup>3</sup> (1.27m <sup>3</sup> )	1.44yd <sup>3</sup> (1.1m <sup>3</sup> )	4'6" (1,376mm)	4'9" (1,445mm)	2,427lb (1,101kg)	A	A	B
1.96yd <sup>3</sup> (1.51m <sup>3</sup> )	1.70yd <sup>3</sup> (1.3m <sup>3</sup> )	5'2" (1,582mm)	5'5" (1,657mm)	2,716lb (1,232kg)	A	B	C
2.29yd <sup>3</sup> (1.75m <sup>3</sup> )	1.96yd <sup>3</sup> (1.5m <sup>3</sup> )	5'11" (1,792mm)	6'2" (1,867mm)	2,945lb (1,336kg)	B	C	-

A. Suitable for materials with density of 2,000 kg/m<sup>3</sup> (3,370 lb/CU · yd) or less

B. Suitable for materials with density of 1,600 kg/m<sup>3</sup> (2,700 lb/CU · yd) or less

C. Suitable for materials with density of 1,100 kg/m<sup>3</sup> (1,850 lb/CU · yd) or less

# DIMENSIONS

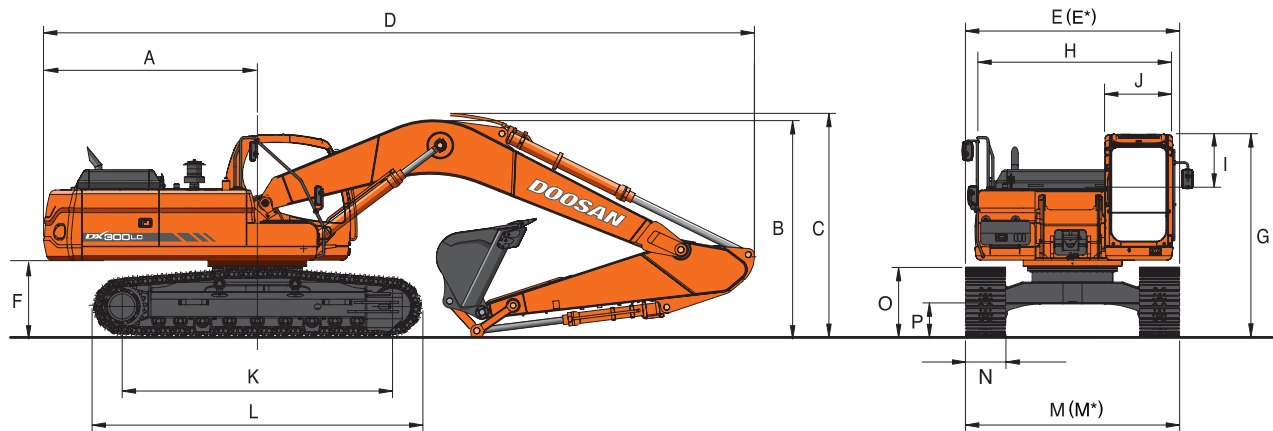

## \* DIMENSIONS

Boom 6,245 mm (20'6") - Arm 3,100 mm (10'2") - Shoe 600 mm (2') - Std

		20'6" (6,245mm)		17'5" (10,000mm)
Boom type (One piece)		20'6" (6,245mm)		17'5" (10,000mm)
Arm type	8'2" (2,500mm)	(Std.) 10'2" (3,100mm)	12'4" (3,750mm)	22'11" (7,000mm)
Bucket type (pcsa)	1.50m <sup>3</sup>	(Std.) 1.27m <sup>3</sup>	1.05m <sup>3</sup>	0.64m <sup>3</sup> (HD)
A Tail Swing Radius	→	10'6" (3,200mm)	←	←
B Shipping Height (Boom)	11'1" (3,369mm)	10'8" (3,250mm)	11'1" (3,366mm)	11'3" (3,427mm)
C Shipping Height (Hose)	11'5" (3,475mm)	11' (3,345mm)	11'5" (3,475mm)	11'4" (3,455mm)
D Shipping Length	35'3" (10,740mm)	34'10" (10,620mm)	35' (10,660mm)	47'2" (14,370mm)
E Shipping Width (Std.)	→	10'6" (3,200mm)	←	←
E* Shipping Width (Narrow)	→	9'10" (3,000mm)	←	←
F C/Weight Clearance	→	3'10" (1,175mm)	←	←
G Height Over CAB.	→	10'1" (3,065mm)	←	←
H House Width	→	9'9" (2,960mm)	←	←
I CAB. Height above House	→	2'10" (845mm)	←	←
J CAB. Width	→	3'2" (960mm)	←	←
K Tumbler Distance	→	13'2" (4,010mm)	←	←
L Track Length	→	16'2" (4,930mm)	←	←
M Undercarriage Width (Std.)	→	10'6" (3,200mm)	←	←
M* Undercarriage Width (Narrow)	→	9'10" (3,000mm)	←	←
N Shoe Width	→	2' (600mm)	←	←
O Track Height	→	3'5" (1,048mm)	←	←
P Car Body Clearance	→	1'8" (500mm)	←	←

## \* DIGGING FORCE (ISO)

Bucket (PCSA)	0.64m <sup>3</sup>	0.80m <sup>3</sup>	1.05m <sup>3</sup>	(Std.) 1.27m <sup>3</sup>	1.50m <sup>3</sup>	1.75m <sup>3</sup>
Digging force	20,400 kgf	20,400 kgf	20,400 kgf	20,400 kgf	20,400 kgf	20,400 kgf
	199 kN	199 kN	199 kN	199 kN	199 kN	199 kN
	44.974 lbf	44.974 lbf	44.974 lbf	44.974 lbf	44.974 lbf	44.974 lbf
Arm	2,500mm		(Std.) 3,100mm		3,750mm	
	16,800 kgf		13,800 kgf		11,900 kgf	
	164 kN		135 kN		116 kN	
	37.037 lbf		30.423 lbf		26.235 lbf	

At power boost (ISO)

# WORKING RANGES

## DX300LC

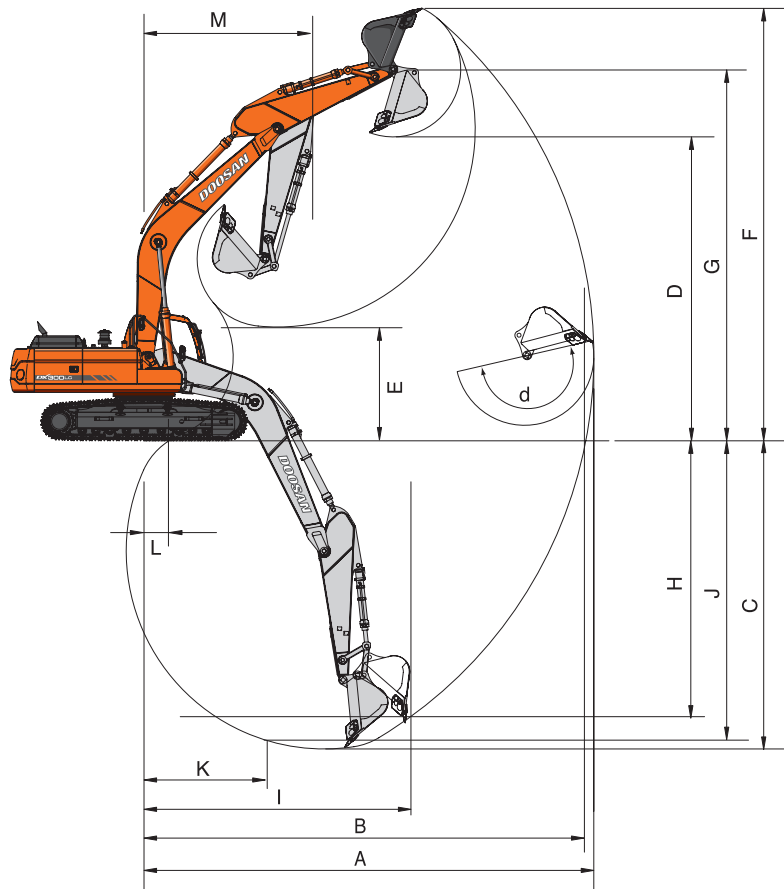

### \* WORKING RANGE

	(Std.) 20'6" (6,245mm)			32'10" (10,000mm)
<b>Boom length</b>	(Std.) 20'6" (6,245mm)			32'10" (10,000mm)
<b>Arm type</b>	8'2" (2,500mm)	(Std.) 10'2" (3,100mm)	12'4" (3,750mm)	22'11" (7,000mm)
<b>Bucket type (pcsa)</b>	1.5m <sup>3</sup>	(Std.) 1.27m <sup>3</sup>	1.05m <sup>3</sup>	0.64m <sup>3</sup>
<b>A. Max. digging reach</b>	33'4" (10,170)	35'3" (10,745)	36'11" (11,270)	57'6" (17,520)
<b>B. Max. digging reach at ground level</b>	32'8" (9,965)	34'7" (10,550)	36'4" (11,085)	57'1" (17,405)
<b>C. Max. digging depth</b>	22'2" (6,760)	24'2" (7,360)	26'3" (8,010)	45'6" (13,875)
<b>D. Max. dumping height</b>	22'9" (6,930)	23'10" (7,260)	24'2" (7,365)	39'2" (11,930)
<b>E. Min. dumping height</b>	10'11" (3,325)	8'11" (2,720)	6'10" (2,070)	7'7" (2,310)
<b>F. Max. digging height</b>	32'8" (9,970)	33'11" (10,330)	34'2" (10,410)	46'5" (14,155)
<b>G. Max. bucket pin height</b>	28' (8,545)	29'1" (8,875)	29'6" (8,980)	43'2" (13,165)
<b>H. Max. vertical wall depth</b>	17'9" (5,405)	20'4" (6,190)	21'11" (6,670)	38'2" (11,630)
<b>I. Max. radius vertical</b>	22'7" (6,870)	22'4" (6,810)	23'1" (7,045)	35'9" (10,905)
<b>J. Max. digging depth (8' level)</b>	21'8" (6,615)	23'6" (7,180)	25'11" (7,895)	45'3" (13,790)
<b>K. Min. radius 8' line</b>	10'7" (3,215)	9'10" (3,005)	10'6" (3,190)	17'8" (5,380)
<b>L. Min. digging reach</b>	6'6" (1,975)	1'11" (595)	-1'8" (-350)	3'7" (1,095)
<b>M. Min. swing radius</b>	13'5" (4,095)	13'3" (4,050)	13'4" (4,065)	20'1" (6,125)
<b>d. Bucket angle (deg)</b>	175°	175°	174°	169°

# LIFTING CAPACITY

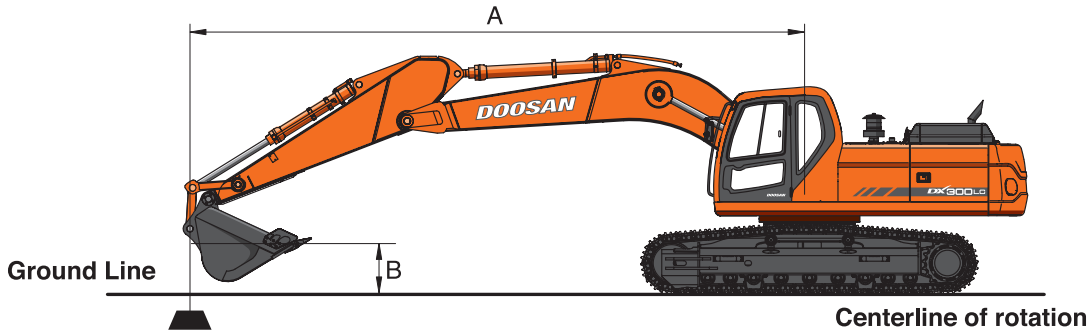

## STANDARD CONFIGURATION

**Metric** Boom : 6,245mm(20'6") Arm : 3,100mm(10'2") Bucket : SAE 1.27m<sup>3</sup> HEAPED(CECE 1.1m<sup>3</sup>) Shoe : 600mm(2') Unit : 1,000kg

A(m)	2		3		4		5		6		7		8		9		Max. Reach				
	🔧	🔧	🔧	🔧	🔧	🔧	🔧	🔧	🔧	🔧	🔧	🔧	🔧	🔧	🔧	🔧	🔧	🔧	🔧	A(m)	
8												*4.58	*4.58					*4.28	*4.28	7.10	
7												*5.11	*5.11					*4.25	*4.25	7.85	
6												*5.32	*5.32	*5.38	4.84			*4.30	*4.30	8.41	
5									*5.99	*5.99	*5.74	*5.74	*5.59	4.78				*4.41	3.99	8.82	
4							*7.76	*7.76	*6.86	*6.86	*6.30	5.86	*5.94	4.68	*5.10	3.80		*4.59	3.72	9.10	
3			*10.78	*10.78	*11.93	*11.93	*9.30	*9.30	*7.85	7.27	*6.95	5.69	*6.37	4.58	5.98	3.74		*4.84	3.54	9.27	
2			*4.70	*4.70	*14.32	13.10	*10.78	9.27	*8.82	7.02	*7.61	5.53	*6.81	4.47	5.90	3.67		*5.18	3.45	9.32	
1			*5.08	*5.08	*14.88	12.64	*11.98	8.95	*9.67	6.80	*8.21	5.38	7.05	4.37	5.84	3.61		5.57	3.44	9.27	
0 (Ground)			*7.00	*7.00	*14.39	12.40	*12.80	8.74	*10.32	6.64	8.60	5.27	6.96	4.29	5.79	3.56		5.68	3.50	9.10	
-1	*6.57	*6.57	*9.46	*9.46	*16.01	12.31	*13.23	8.63	*10.72	6.54	8.51	5.19	6.91	4.24				5.94	3.65	8.82	
-2	*9.33	*9.33	*12.34	*12.34	*16.87	12.31	*13.29	8.59	*10.84	6.50	8.48	5.16	6.89	4.22				6.39	3.93	8.41	
-3	*12.28	*12.28	*15.76	*15.76	*16.27	12.38	*12.98	8.62	*10.65	6.51	8.49	5.17						7.13	4.38	7.84	
-4	*15.65	*15.65	*19.54	*19.54	*15.19	12.52	*12.23	8.71	*10.04	6.58	*8.24	5.25						*8.08	5.15	7.09	
-5	*19.75	*19.75	*17.08	*17.08	*13.45	12.74	*10.85	8.87	*8.72	6.73								*8.54	6.59	6.09	
-6					*10.56	*10.56													*8.98	*8.98	4.66

## Feet

Unit : 1,000lb

A(ft)	10'		15'		20'		25'		30'		Max. Reach				
	🔧	🔧	🔧	🔧	🔧	🔧	🔧	🔧	🔧	🔧	🔧	🔧	🔧	A(ft)	
25													*9.39	*9.39	24.4
20								*11.74	11.66				*9.46	*9.46	27.5
15							*13.89	*13.89	*12.79	11.37			*9.88	8.51	29.5
10	*28.04	*28.04	*22.23	*22.23	*16.96	15.66	*14.41	10.95	*12.07	8.01			*10.65	7.83	30.5
5	*10.92	*10.92	*28.09	23.01	*20.04	14.87	*16.12	10.53	12.61	7.81			*11.85	7.58	30.6
0 (Ground)	*15.97	*15.97	*31.46	22.11	*22.34	14.30	16.57	10.20					12.53	7.72	29.10
-5	*24.52	*24.52	*32.42	21.81	23.37	14.02	16.38	10.03					13.56	8.33	28.3
-10	*35.67	*35.67	*31.33	21.90	*23.01	14.02	16.43	10.07					15.83	9.72	25.8
-15	*39.72	*39.72	*27.82	22.34	*20.33	14.33							*18.39	12.89	21.6
-20													*19.87	*19.87	14.9

1. Ratings are based on SAE J1097
2. The load point is a hook located on the back of the bucket.
3. \* Rated loads are based on hydraulic capacity.
4. Rated loads do not exceed 87% of hydraulic capacity or 75% of tipping capacity.

🔧 : Rating Over Front  
 🔄 : Rating Over Side or 360 degree





**Option 1**

**Metric** Boom : 6,245mm(20'6") Arm : 2,500mm(8'2") Bucket : SAE 1.50m<sup>3</sup> HEAPED(CECE 1.3m<sup>3</sup>) Shoe : 600mm(2') Unit : 1,000kg

A(m)	2		3		4		5		6		7		8		Max. Reach		A(m)
8															*5.77	*5.77	6.23
7											*5.82	*5.82			*5.84	*5.84	7.07
6									*6.06	*6.06	*5.95	*5.95			*5.96	5.10	7.69
5							*7.35	*7.35	*6.71	*6.71	*6.31	5.91	*6.12	4.69	*6.11	4.55	8.14
4					*10.83	*10.83	*8.72	*8.72	*7.55	7.39	*6.83	5.77	*6.41	4.62	*6.30	4.20	8.44
3					*13.46	13.34	*10.20	9.45	*8.47	7.14	*7.43	5.61	*6.77	4.52	6.37	3.98	8.62
2					*14.73	12.72	*11.54	9.07	*9.36	6.90	*8.02	5.46	7.11	4.42	6.23	3.87	8.68
1					*12.87	12.40	*12.53	8.81	*10.09	6.71	*8.54	5.33	7.02	4.34	6.24	3.86	8.62
O (Ground)					*14.42	12.28	*13.11	8.65	*10.59	6.59	8.56	5.23	6.95	4.28	6.40	3.94	8.44
-1	*7.59	*7.59	*10.55	*10.55	*16.92	12.27	*13.30	8.59	*10.83	6.52	8.50	5.18	6.92	4.25	6.75	4.15	8.13
-2	*11.45	*11.45	*14.64	*14.64	*16.44	12.32	*13.13	8.59	*10.78	6.51	8.50	5.18			7.37	4.52	7.68
-3	*15.37	*15.37	*19.38	*19.38	*15.56	12.44	*12.58	8.66	*10.36	6.55	8.56	5.23			8.44	5.16	7.06
-4	*19.92	*19.92	*17.76	*17.76	*14.16	12.64	*11.52	8.80	*9.40	6.57					*8.98	6.34	6.22
-5			*14.80	*14.80	*11.91	*11.91	*9.56	9.04							*9.48	8.94	5.04
-6					*10.25	*10.25											

**Feet**

Unit : 1,000lb

A(ft)	10'		15'		20'		25'		Max. Reach		A(ft)
25									*12.76	*12.76	21.7
20					*13.23	*13.23	*13.11	11.43	*13.11	11.39	25.1
15			*18.59	*18.59	*15.40	*15.40	*13.92	11.19	*13.64	9.67	27.2
10			*24.76	23.95	*18.31	15.38	*15.35	10.81	14.08	8.80	28.3
5			*29.82	22.51	*21.07	14.65	16.82	10.43	13.70	8.50	28.5
O (Ground)	*15.04	*15.04	*32.13	21.88	*22.93	14.18	16.52	10.16	14.10	8.69	27.8
-5	*28.38	*28.38	*32.16	21.77	23.35	14.01	16.42	10.07	15.50	9.52	26.0
-10	*42.83	*42.83	*30.20	22.01	*22.37	14.12			18.76	11.48	23.1
-15	*35.36	*35.36	*25.45	22.63					*20.43	16.58	18.4

1. Ratings are based on SAE J1097
2. The load point is a hook located on the back of the bucket.
3. \* Rated loads are based on hydraulic capacity.
4. Rated loads do not exceed 87% of hydraulic capacity or 75% of tipping capacity.

: Rating Over Front

: Rating Over Side or 360 degree



### Option 2

**Metric** Boom : 6,245mm(20'6") Arm : 3,750mm(12'4") Bucket : SAE 1.05m<sup>3</sup> HEAPED(CECE 0.9m<sup>3</sup>) Shoe : 600mm(2') Unit : 1,000kg

A(m)	2		3		4		5		6		7		8		9		Max. Reach		
																			A(m)
8																	*3.55	*3.88	7.78
7													*4.50	*4.50			*3.54	*3.54	8.47
6													*4.78	*4.78			*3.59	*3.59	8.99
5											*5.10	*5.10	*5.06	4.94	*4.71	4.00	*3.69	*3.69	9.38
4									*6.06	*6.06	*5.70	*5.70	*5.45	4.83	*5.31	3.93	*3.83	3.46	9.64
3			*14.00	*14.00	*10.10	*10.10	*8.19	*8.19	*7.09	*7.09	*6.39	5.85	*5.92	4.71	*5.62	3.85	*4.04	3.31	9.80
2			*11.17	*11.17	*12.72	*12.72	*9.80	9.54	*8.14	7.20	*7.11	5.67	*6.42	4.58	*5.95	3.77	*4.31	3.22	9.85
1			*7.98	*7.98	*14.80	12.93	*11.20	9.15	*9.11	6.95	*7.79	5.50	*6.90	4.46	5.92	3.69	*4.66	3.20	9.80
O (Ground)	*4.61	*4.61	*8.33	*8.33	*16.16	12.55	*12.27	8.87	*9.91	6.75	*8.38	5.35	7.04	4.36	5.85	3.62	*5.13	3.24	9.64
-1	*6.69	*6.69	*9.76	*9.76	*16.75	12.35	*12.96	8.69	*10.48	6.61	8.57	5.25	6.96	4.29	5.80	3.58	5.44	3.36	9.37
-2	*8.68	*8.68	*11.78	*11.78	*17.04	12.27	*13.28	8.60	*10.79	6.52	8.50	5.18	6.91	4.24			5.79	3.56	8.99
-3	*10.97	*10.97	*14.29	*14.29	*16.79	12.29	*13.24	8.58	*10.82	6.50	8.48	5.16	6.90	4.24			6.34	3.90	8.46
-4	*13.56	*13.56	*17.42	*17.42	*16.07	12.38	*12.81	8.63	*10.51	6.53	8.51	5.19					7.25	4.46	7.78
-5	*16.61	*16.61	*19.20	*19.20	*14.81	12.54	*11.89	8.74	*9.73	6.52							*8.16	5.43	6.87
-6	*20.36	*20.36	*16.33	*16.33	*12.75	*12.75	*10.20	8.94									*8.80	7.43	5.65

### Feet

Unit : 1,000lb

A(ft)	10'		15'		20'		25'		30'		Max. Reach		
													A(ft)
25							*9.68	*9.68			*7.80	*7.80	26.6
20							*10.37	*10.37			*7.89	*7.89	29.4
15							*11.58	*11.58	*10.54	8.50	*8.25	7.90	31.2
10	*29.71	*29.71	*19.34	*19.34	*15.34	*15.34	*13.34	11.26	*12.28	8.27	*8.88	7.30	32.2
5	*20.58	*20.58	*25.73	23.64	*18.70	15.23	*15.26	10.77	12.81	8.00	*9.84	7.06	32.3
O (Ground)	*18.94	*18.94	*30.17	22.42	*21.46	14.53	16.75	10.37	12.57	7.78	*11.30	7.14	31.8
-5	*24.19	*24.19	*32.20	21.87	*23.12	14.12	16.47	10.11	12.44	7.66	12.35	7.61	30.2
-10	*32.31	*32.31	*32.12	21.78	23.33	13.99	16.39	10.04			14.06	8.65	27.8
-15	*43.71	*43.71	*29.84	21.05	*21.94	14.15					*17.46	10.90	23.11
-20	*34.79	*34.79	*24.20	22.75							*19.55	17.07	18.1

1. Ratings are based on SAE J1097
2. The load point is a hook located on the back of the bucket.
3. \* Rated loads are based on hydraulic capacity.
4. Rated loads do not exceed 87% of hydraulic capacity or 75% of tipping capacity.

: Rating Over Front  
 : Rating Over Side or 360 degree

# STANDARD AND OPTIONAL EQUIPMENT

## \* STANDARD EQUIPMENT

### • Hydraulic system

- Boom and arm flow regeneration
- Boom and arm holding valves
- Swing anti-rebound valves
- Spare ports (valve)
- One-touch power boost

### • Cabin & Interior

- Viscous cab mounts
- All weather sound suppressed type cab
- Air conditioner
- Adjustable suspension seat with head rest and adjustable arm rest
- Pull-up type front window and removable lower front window
- Room light
- Intermittent windshield wiper
- Cigarette lighter and ashtray
- Cup holder
- Hot and Cool box
- LCD color monitor panel
- Fuel control dial
- AM/FM radio and cassette player
- Remote radio ON/OFF switch
- 12V spare powers socket
- Serial communication port for laptop PC interface
- Joystick lever with 3 switches
- Sunvisor
- Sun roof

### • Safety

- Large handrails and step
- Punched metal anti-slip plates
- Seat belt
- Hydraulic safety lock lever
- Safety glass
- Hammer for emergency escape
- Right and left rearview mirrors
- Travel alarm

### • Other

- Double element air cleaner
- Pre-cleaner
- Water separator
- Dust screen for radiator/oil cooler
- Engine overheat prevention system
- Engine restart prevention system
- Self-diagnostic system
- Alternator(24V, 50 amps)
- Electric horn
- Halogen working lights(frame mounted 2, boom mounted 2)
- Hydraulic track adjuster
- Track guards
- Double fuel filter
- Greased and sealed track link

## \* OPTIONAL EQUIPMENT

Some of these optional equipments may be standard in some markets. Some of these optional equipments cannot be available on some markets. You must check with the local DOOSAN dealer to know about the availability or to release the adaptation following the needs of the applications.

### • Safety

- Boom and arm hose rupture protection valve
- Overload warning device
- Cabin Top/Front guard(ISO 10262, FOGS standard)
- Travel & swing alarm
- Rotation beacon

### • Cabin & Interior

- Air suspension seat
- MP3/CD player

### • Other

- Piping for crusher
- Piping for quick clamp
- Breaker filter
- 700mm/800mm/850mm shoe
- Full track guards
- Lower wiper
- Fuel heater
- Double grouser shoe

**Seoul Office :**

Doosan Tower 26TH FL. 18-12, Euljiro-6Ga,  
Jung-Gu, Seoul, Korea 100-730

Tel : +82-2-3398-8114

Fax : +82-2-3398-8117

[www.doosaninfracore.com](http://www.doosaninfracore.com)

**Doosan Infracore Europe S.A.**

1A, Rue Achille Degrace, 7080 Frameries, Belgium  
Tel : +32-65-61-3230 Fax : +32-65-67-7338

**Doosan Infracore U.K., Ltd.**

Doosan House, Unit 6.3, Nantgarw Park, Cardiff CF47QU, U.K.  
Tel : +44-1443-84-2273 Fax : +44-1443-84-1933

**Doosan Infracore Germany GmbH**

Hans-Böeckler strasse 29, D-40764, Langenfeld-Fuhrkamp, Germany  
Tel : +49-2173-8509-18 Fax : +49-2173-8509-45

**Doosan Infracore France**

ZAC de La Clef Saint Pierre - Buroplus 2 1A Avenue Jean d'Alembert  
78990 Elancourt, France  
Tel : +33-(0)1-30-16-21-41 Fax : +33-(0)1-30-16-21-44

**Doosan Infracore America Corporation**

2905 Shawnee Industrial Way, Suwanee, Georgia 30024, U. S. A  
Tel : +1-770-831-2200 Fax : +1-770-831-0480

**Doosan Infracore (China) Co., Ltd.**

#28, Wuzhishan Road, Eco. & Tech, Development Zone, Yantai, Shandong, China  
Tel : +86-535-638-2000 Fax : +86-535-638-2004

**Doosan Infracore Xinjiang Machinery Co.,Ltd.**

No, 178, Hetanbei Road, Wulumuqi, Xinjiang, China  
Tel : +86-991-469-7217 Fax : +86-991-469-8641

**Doosan Infracore Liaoning Machinery Co.,Ltd.**

No.32 DongLing Road, DongLing District, ShenYang, Liaoning, China  
Tel : +86-24-8841-1407 Fax : +86-24-8841-1404

**Doosan Infracore South Africa (PTY)LTD.**

60C Electron Road, Isando 1600, Johannesburg, South Africa  
Tel : 27-11-974-2095 Fax : 27-11-974-2778

**Doosan Infracore Middle East Center(Dubai)**

P.O.Box 183127, Al-Serkal Building, Air Port Road,Dubai, U.A.E  
Tel : +971-4-295-2781~2 Fax:+971-4-295-2783



PBP D300C000 0701

The illustrations do not necessary show the product in standard version.  
All products and equipments are not available in all markets.  
Materials and specifications are subjects to change without prior notice.