



Doosan Infracore
Construction Equipment

SOLAR140LCV

Engine Power : DIN 6271,net 71kw(96ps)@1,850 rpm
 SAE J 1349,net 71kw(95HP)@1,850 rpm
Operational Weight : 13,900kg (30,600 lb)
Bucket capacity(PCSA) : 0.28 ~ 0.76m³(0.37 ~ 0.99 cu.yd)



Performance

This hydraulic excavator is equipped with the air-to-air intercooler engine, which has the greatest power output in its class and excellent fuel economy. It assures outstanding workability, productivity, and efficiency through the e-EPOS system, the new and improved version of EPOS System. This will assure increase in operating capacity and decrease in fuel consumption.

Improved maneuverability and control

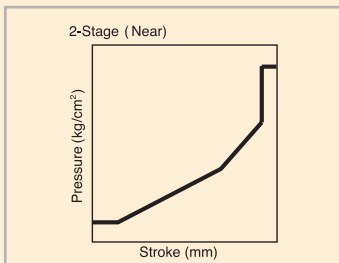

New technologically advanced control valve and joystick valves have been installed to allow speedy, smooth and responsive control.

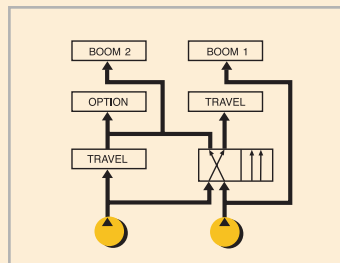

Advanced hydraulic circuit separates the oil flow for travel and boom function to allow precise and safe operation when handling loads during travel.

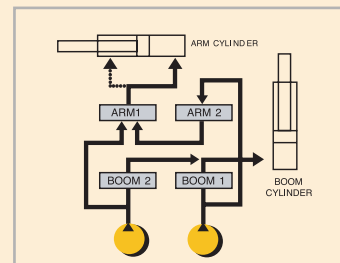

The circuits for the boom, arm, and bucket have been improved to assure smooth and confident control during combination.

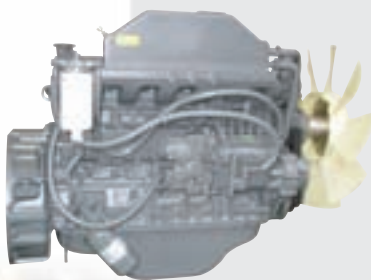

Air to Water Intercooler Engine

Greatest power output and high-efficiency engine in its class.

Environment friendly, Green engine.

This machine is equipped with the engine meeting the U.S. EPA Tier-II Regulations and European stage-II Regulations requiring the reduction of harmful NOx, PM, HC, and CO emissions.

Compatible with the European New Noise Control Requirements



Joystick grip with 2 switches

Spare switches are installed on both joystick grips to control the additional attachment.

Excellent Reliability

Doosan's world-class center for product reliability performs sophisticated testing on all completed products, to ensure they meet or exceed market standards.

Improved swing mechanism. (Equipped with anti-rebound valve)



Swing anti-rebound valve is installed as standard equipment, which allows the operator to stop the upper structure at the desired position. As a result, operating efficiency has been greatly improved.



Emergency throttle cable

In the event of engine speed control dial malfunction, emergency throttle cable mounted in the cabin can be used to manually control engine speed.



Working Environment

Wide operator cabin space meet the ISO Standards and expanded all-round visibility. The low-noise, low-vibration type comfortable cabin provides the operator with safe and ergonomic operating environment.



Good visibility

The enlarged right-hand glass and the minimized crosswise strut in windshield have been achieved to increase the visual range by 15% when compared to the previous machine.



Increased foot space

Instruments, controls, and accessories have been ergonomically located in the cabin and 300mm seat slide has been achieved to provide ample space for operator's feet and legs.



Long wind shield wiper blade

Front visibility is further improved by using the lengthened wiper blade (wiper area increased 35% compared to previous machine.)

Large ceiling cover

The ceiling cover can be opened to confirm the bucket operation even at the maximum excavating height. (Visual range increased by 25% compared to previous machine.)



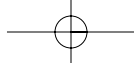

Cup holder

A folding style cup holder has been installed in the cabin allowing the operator to easily store a can or cup.



12V Spare Power Socket

This socket can be used for charging a cellular phone or powering a small 12V DC electrical device.

Fresh Air Type Air Conditioner

One touch selector switch for the air conditioner and heater output, featuring a multi-vent circulation system that allows for greater cooling / heating performance. Improved front window defroster system has been added to provide enhanced clarity and visibility during any working condition.

- Easy replaceable air filter.
- Larger cool air intake vents.
- Industry standard fresh air/recirculation control system incorporated.
- Modular electric fan condenser compartment.

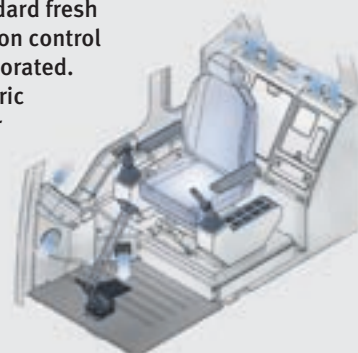

Low Vibration Cab Mounting System

By using a total isolating seal design (full sealing) outside noise has been drastically reduced to the levels comparable to that in a modern car. A viscous sealed mounting system has been incorporated, and the frame, cabin and seat have been designed to absorb major and minor vibrations, resulting in a significant decrease in vibration felt by the operator.

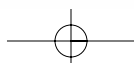
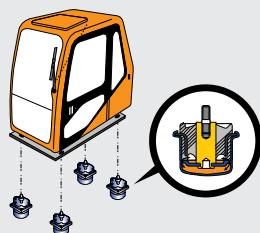

Maintenance

Quick and easy service checks, maximizing the excavator's life expectancy.

PC monitoring function (SMS)

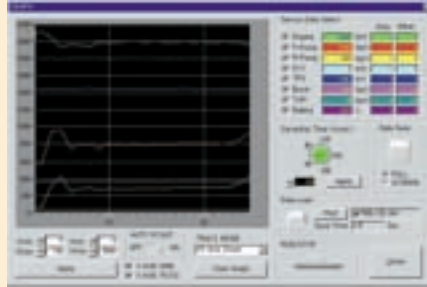

By connecting a laptop PC to the controller (e-EPOS controller) of the machine, data such as pump pressure and engine RPM can be displayed graphically. Also other various machine status data can be stored in memory and printed out using a printer.



Electrical control access box

Pull-out style drawer for electrical control access box allows for easy service and maintenance.



Engine oil drain valve

The engine oil drain valve with quick coupler provides fast and environmentally sound serviceability.



Water separator

The transparent glass water separator is mounted at a location easily accessible from the ground allowing easy maintenance of the fuel system.



Graphic display LCD Monitor panel

The information monitor panel displays both text and symbols for easy recognition of machine status and various other data

Simplified operation mode selection

The 3 work modes from the previous models have been reduced to digging and trenching modes for easy selection.

- **Digging Mode :**
General Excavating, Ground Leveling, Loading Dump Truck, allows for versatility.
- **Trenching Mode :**
trenching or excavating of side wall, operations which require heavy swing work.



FAILURE LOG
CODE: 12 N:001 0075Hr
Press up s/v open
PRV:▲ NXT:▼ 01/01

Self-diagnosis and fault history memory functions

Current faults and past faults history of the excavator control system are displayed and memorized on a real-time basis to enable correct diagnosis and quick repair.



02/05 [MO] 11:30A
ENG SPEED
2059
RPM

Real-time clock with day / date

The real-time clock displays date and day in easy to read format.

1. Fuel Filter
Hrs: 0232 Reset

Filter / oil operating hour display

The hours in use for 8 filters and oils can be displayed so that replacement intervals can be easily recognized.

LANGUAGE
Francais
Deutsch 4
SET: English

Multiple language display

The user menu can be displayed in multiple languages for the operator's convenience.

EPPR CURRENT
598
mA

Real-time machine data display

Displays 23 different machine status data and information such as pump delivery pressure and engine RPM.

Technical Data

Engine

Model	DOOSAN DB58TIS
Type	Water-cooled, 4-cycle, direct injection .
Aspiration	Turbocharged Air-to-Water intercooled
No. of cylinders	6
Rated flywheel horse power	
DIN 6271, net	71KW (96PS) at 1,850rpm
DIN 6271,Gross	74 KW (100PS) at 1,850rpm
SAEJ1349,net	71KW (95HP) at 1,850rpm
SAEJ1349,Gross	74 KW (99HP) at 1,850rpm
Piston displacement	5,785cc (353cu.in)
Maximum torque	40kgf.m (392Nm, 290 lbf.ft) @1,850rpm
Bore and stroke	102mm × 118mm (4.0" × 4.6")
Starting system	24V Electric motor
Batteries	2 × 12 V × 100AH

Hydraulic system

e-EPOS (Electronic Power Optimizing System) allows the operator to maximize work efficiency over a full range of operating conditions and to minimize fuel consumption.

- Hydraulic system assures fully independent and combined operations.
- Automatic 2 speed travel system for high traction force and travel speed.
- Cross-sensing and fuel saving pump system.
- Auto idle system.
- 2-Working /2-power mode selection system.
- Computer aided engine-pump control.

Main pumps	2 variable displacement axial piston pumps.
Max. oil flow	2 × 116 ℓ/min (2 × 30.7 US gpm, 2 × 26 Imp gpm)
Pilot pump	Gear pump
Max. oil flow	27.7 ℓ/min (7.3US gpm,6.1Imp gpm)
Swing motor	
Relief valve	265bar (3,840psi, 270 kgf/cm ²)

Main relief valves

Boom/Arm/Bucket	Normal : 324bar (4,690psi, 330kgf/cm ²) Power Boost : 343bar (4,980 psi,350kgf/cm ²)
Travel circuit	324bar (4,690psi,330kgf/cm ²)

Hydraulic cylinders

High-strength piston rods and tubes are used. Cylinder cushion mechanism is provided for all cylinders to assure shock-free operation and extend life of cylinder.

Cylinders	Q'ty	Bore × Rod dia. × Stroke
Boom		100 × 70 × 1,080mm (4.0 " × 2.8" × 42.5")
Arm		115 × 80 × 1,085mm (4.5 " × 3.1" × 42.7")
Bucket		95 × 65 × 1,365mm (3.8 " × 2.6" × 53.7")

Super-structure revolving frame

A deep, full-reinforced box section. Heavy-gauge steel plates used for ruggedness.

Operator's cab

A roomy, independent, shock and noise-free operator's cab, 4 side safety glass windows give all-round visibility. Front window slides up and stores in the roof and side window can be opened for ventilation. Fully adjustable suspension seat. Air conditioner. ISO standard cab.

Noise Levels (dynamic value)

LWA External noise	
Guaranteed Sound Power Level	103dB (A) (2000/14/ EC)
Measured Sound Power Level	101dB (A) (2000/14/ EC)
LpA Operator noise	74dB (A) (HIGH IDLE)

Controls. 2 implement levers

Pilot pressure control type. Right lever is boom and bucket control, left lever for swing and arm control.

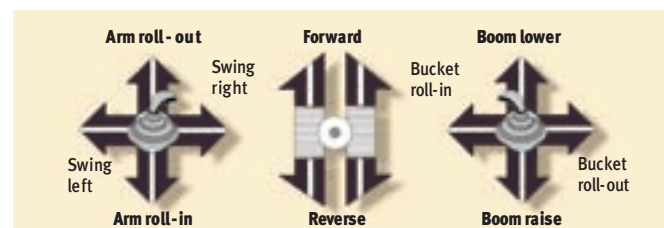

2 Travel pedals with levers

Pilot pressure control type. Independent drive at each track allows counter-rotation of the tracks. Levers are detachable.

Swing mechanism

High-torque, axial piston motor with planetary reduction gear bathed in oil. Swing circle is singlerow, shear type ball bearing with induction-hardened internal gear. Internal gear and pinion gear immersed in lubricant. Swing parking brake is spring-set, hydraulic-released disc type.

- **Swing speed** 0 to 12 rpm(min⁻¹)
- **Rear swing radius** 2,200mm (7'2")

Drive

Each track is driven by an independent, high-torque, axial piston motor through planetary reduction gear. Two levers or foot pedal control provide smooth travel or counter-rotation upon demand.

Travel speed (High/Low) 4.9/ 3.4km/h
(3.1/ 2.1mph)

Maximum traction force 12,570kgf (27,710lbf)

Gradeability 35° (70%) continuous

Undercarriage

Tractor type undercarriage. Heavy-duty track frame, all welded stress-relieved structure. Top grade materials are used for toughness. Side frames are welded, securely and rigidly, to the track frame. Lifetime-lubricated track rollers, idlers and sprockets with floating seals. Track shoes of induction-hardened rolled alloy with triple grousers. Specially heart-treated connecting pins. Hydraulic track adjusters with shock-absorbing recoil springs.

Buckets

Capacity		Width		Weight	Recommendation		
PCSA, heaped	CECE, heaped	Without side cutters	With side cutters		1.9m (6'3") Arm	2.5m (8'3") Arm	3.0m (9'10") Arm
0.28m ³ (0.37yd ³)	0.25m ³	544mm (1'9")	639mm (2'1")	306kg (675lb)	A	A	A
0.40m ³ (0.52yd ³)	0.35m ³	766mm (2'6")	861mm (2'10")	360kg (790lb)	A	A	A
0.52m ³ (0.68yd ³)	0.45m ³	948mm (3'1")	1,043mm (3'5")	415kg (920lb)	A	A	B
0.58m ³ (0.76yd ³)	0.50m ³	1,040mm (3'5")	1,140mm (3'9")	430kg (950lb)	A	A	B
0.64m ³ (0.84yd ³)	0.55m ³	1,124mm (3'8")	1,219mm (4')	460kg (1,010lb)	A	B	C
0.76m ³ (0.99yd ³)	0.65m ³	1,304mm (4'3")	1,399mm (4'7")	515kg (1,135lb)	B	C	-

A. Suitable for materials with density of 2,000kg/m³ (3,370lb / cu-yd) or less
 B. Suitable for materials with density of 1,600kg/m³ (2,700lb / cu-yd) or less
 C. Suitable for materials with density of 1,100kg/m³ (1,850lb / cu-yd) or less

Number of rollers and shoes (each side) ground contact area

Upper rollers 1

(Standard shoe)

Lower rollers 7

Track shoes 46

Overall track length 3,490 mm (11'5")

Brake

Two oil disc brake on final drive input shafts. Parking brake is spring-set, hydraulic-released disc type.

Weight

Equipped with 4.6m (15'1") boom, 2.5m (8'2") arm, and 0.52m³ (0.68yd³; PCSA heaped) bucket and 600mm (2') shoes.

Shoe type	Shoe width	Operating weight	Ground pressure
Triple grouser	500mm (1'8")	13,700 kg (30,200lb)	0.41 kgf/cm ² (40kpa,5.8psi)
	600mm (2')	13,900kg (30,600lb)	0.35 kgf/cm ² (34kpa,5.0psi)
	700mm (2'4")	14,100kg (31,100lb)	0.3 kgf/cm ² (29kpa,4.3psi)

Service refill capacities

	Liters	US gal	Imp gal
Fuel tank	230	60.8	50.6
Cooling system	22.0	5.8	4.8
Lubrication	Liters	US gal	Imp gal
Engine oil	19	5.0	4.2
Swing drive (each)	3.0	0.8	0.7
Final drive (each)	2.5	0.7	0.6
Hydraulic system	165	43.6	36.3
Hydraulic tank	89	23.5	19.6

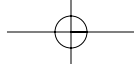

Dimensions & Working Ranges

Dimensions

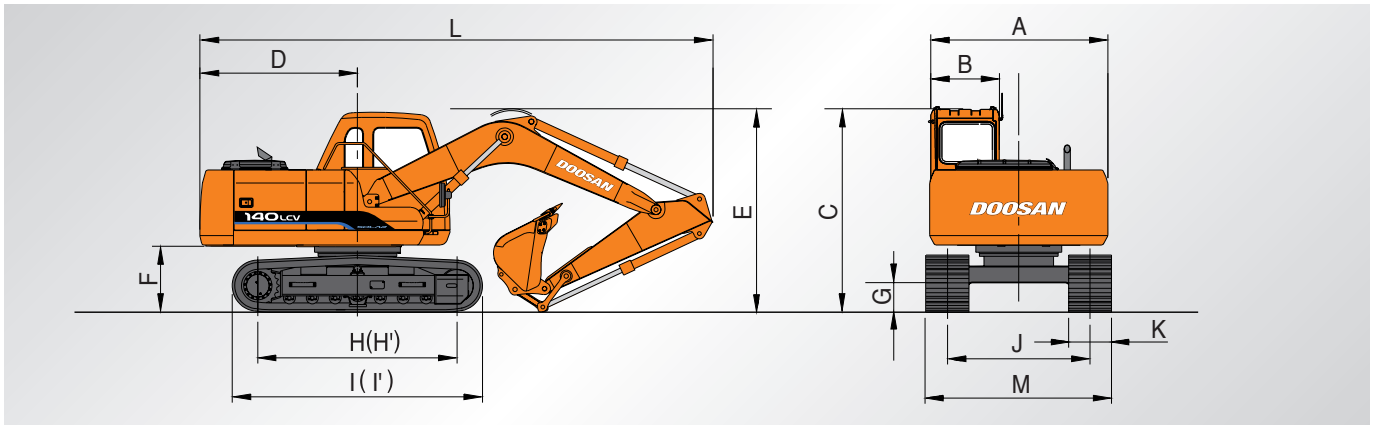

A Overall width of upper structure	2,490mm (8'2")
B Overall width of cab	960mm (3'2")
C Overall height of cab	2,830mm (9'3")
D Tail swing radius	2,200mm (7'2")
E Overall height	2,760mm (9'1")
F Clearance under counterweight	920mm (3'1")
G Ground clearance	410mm (1'4")
H Tumbler distance (standard track)	2,780mm (9'1")
H' Tumbler distance (long track)	3,035mm (10')
I Track length (standard track)	3,493mm (11'5")
I' Track length (long track)	3,750mm (12'4")
J Track gauge	2,000mm (6'6")
K Track shoe width	600mm (2')
L Overall length	7,700mm (25'3")
M Overall track width with 600 mm (24") shoe	2,600mm (8'5")

Working ranges (4.6m Boom +2.5m Arm)

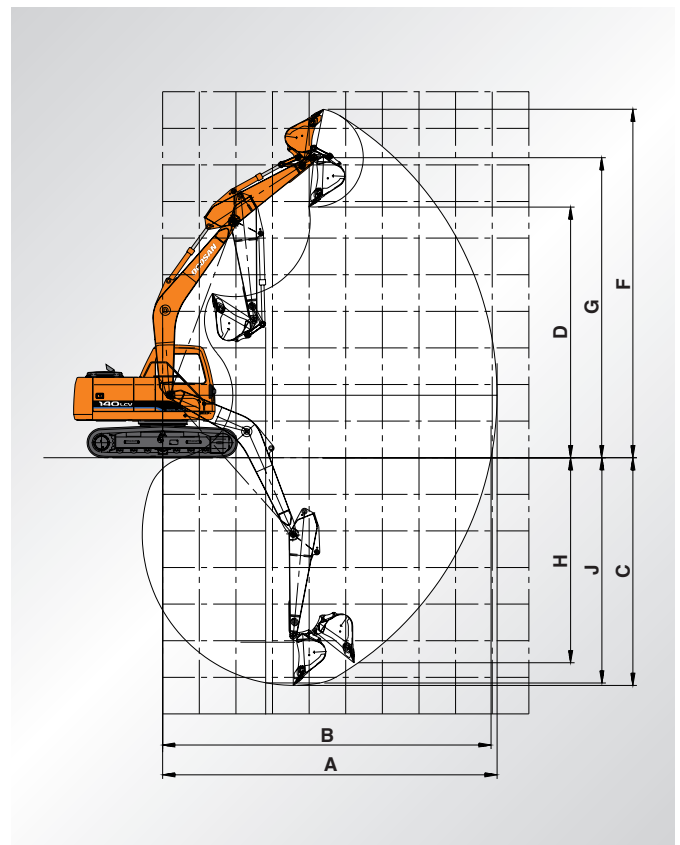

Digging forces (Maximum radial tooth forces)

	2.5m (8'3") Arm	1.9m (6'3") Arm	3.0m (9'10") Arm
Bucket digging force *	8,300kgf	8,300kgf	8,300kgf
	82kN	82kN	82kN
	18,300 lbf	18,300 lbf	18,300 lbf
Arm digging force *	6,300 kgf	7,100kgf	5,600kgf
	62kN	70kN	55kN
	13,900lbf	15,700lbf	12,300 lbf

*At power boost

Boom length	4.0m (13'1")		4.6m (15'1")	
	Arm length		2.5m (7'9")	3.0m (11'6")
A. Max. digging reach	7,020mm (23'1")		8,260mm (27'2")	8,740mm (28'8")
B. Max. digging reach at ground level	6,840mm (22'5")		8,110mm (26'7")	8,600mm (28'3")
C. Max. digging depth	4,670mm (15'4")		5,630mm (18'6")	6,130mm (20'2")
D. Max. digging height	7,350mm (24'2")		8,620mm (28'3")	8,950mm (29'4")
E. Max. dumping height	4,900mm (16'5")		6,200mm (20'4")	6,530mm (21'5")
F. Max. vertical wall digging depth	3,670mm (12')		5,070mm (16'7")	5,660mm (18'7")
G. Max. digging depth (8' level)	4,310mm (14'1")		5,380mm (17'7")	5,920mm (19'5")

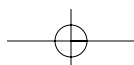

Standard & Optional Equipment

SOLAR 140LCV

Standard equipment

Hydraulic system

- Boom and arm flow regeneration
- Boom and arm holding valves
- Swing anti-rebound valves
- Spare ports (valve)
- One-touch power boost

Cabin & Interior

- Viscous cab mounts
- All weather sound suppressed type cab
- Air conditioner
- Adjustable suspension seat with head rest and adjustable arm rest
- Pull-up type front window and removable lower front window
- Room light
- Intermittent windshield wiper
- Cigarette lighter and ashtray
- Cup holder
- Hot & cool box
- Graphic display monitor
- Fuel control dial
- AM/FM Radio and cassette player
- Remote radio ON/OFF switch
- 12V spare power socket
- Serial communication port for laptop PC interface
- Joystick lever with 2 switches

Safety

- Large handrails and step
- Punched metal anti-slip plates
- Seat belt
- Hydraulic safety lock lever
- Safety glass
- Hammer for emergency escape
- Right and left rearview mirrors
- 360 degree fan guard

Others

- Double element air cleaner
- Pre-cleaner
- Water separator
- Dust screen for radiator
- Engine overheat prevention system
- Engine restart prevention system
- Self-diagnostic system
- Alternator (24V, 60 amps)
- Electric horn
- Halogen working lights (frame mounted 2, boom mounted 2)
- Hydraulic track adjuster
- Track guards

Optional equipment

Safety

- Boom and arm hose rupture protection valve
- Overload warning device
- Cabin Top/Front guard (ISO 10262, FOGS standard)
- Travel alarm
- Travel & swing alarm
- Rotating beacon

Cabin & Interior

- Sunvisor
- Sun roof
- Joystick lever with 3 switches

Others

- Piping for hammer (one way)
- Piping for rotation
- Additional work lights on the cabin (① 2 front lamps, ② 4 front and 2 rear lamps)
- Large capacity alternator (24V, 80A)
- Electric fuel supply pump



Boom and arm hose rupture protection valve



Sunvisor



Additional work lights on the cabin



Electric fuel supply pump



Rotating beacon

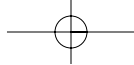

Lifting Capacities

Standard

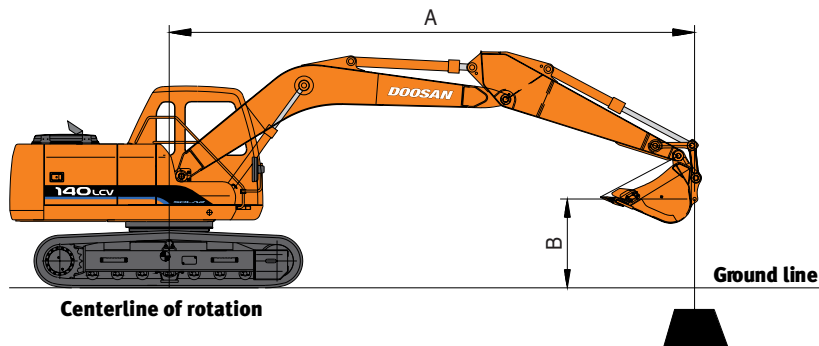

Boom : 4.6m (15'1")
Arm : 2.5m (8'2")
Bucket: PCSA 0.52 m³ (CECE 0.45m³)
Shoe : 600mm (2')

Metric

Unit : 1,000 kg

A (m) \ B (m)	2		3		4		5		6		7		Max. Reach		A (m)
	☐	☐☐	☐	☐☐	☐	☐☐	☐	☐☐	☐	☐☐	☐	☐☐	☐	☐☐	
6							* 2.35	* 2.35					* 2.04	* 2.04	5.76
5							*2.41	*2.41	* 2.46	2.29			*2.01	*2.01	6.42
4					* 2.73	* 2.73	*2.71	*2.71	*2.73	2.26			*2.05	1.83	6.86
3	*6.15	*6.15	* 4.07	* 4.07	*3.47	*3.47	*3.15	2.96	*2.98	2.22	*2.22	1.71	*2.13	1.69	7.13
2			*5.96	*5.96	*4.42	4.03	* 3.70	2.86	*3.28	2.17	2.69	1.69	*2.27	1.62	7.26
1			*7.53	5.97	*5.31	3.88	*4.22	2.79	3.38	2.12	2.66	1.66	*2.44	1.60	7.25
0	*2.64	*2.64	*6.87	5.81	*5.99	3.76	4.40	2.71	3.33	2.07	2.64	1.64	2.62	1.63	7.12
-1	*4.17	*4.17	*7.74	5.78	6.23	3.71	4.36	2.67	3.31	2.05			2.77	1.73	6.83
-2	*5.93	*5.93	*8.58	5.77	6.22	3.70	4.35	2.67	3.30	2.05			3.08	1.92	6.37
-3	*8.16	*8.16	*8.00	5.83	*5.99	3.73	4.37	2.69					3.67	2.28	5.70
-4	*9.59	*9.59	*6.76	5.97	*5.05	3.80							*4.35	3.07	4.71

Feet

Unit : 1,000 lb

A (ft) \ B (ft)	5'		10'		15'		20'		Max. Reach		A (ft)
	☐	☐☐	☐	☐☐	☐	☐☐	☐	☐☐	☐	☐☐	
20					*5.18	*5.18			* 4.48	* 4.48	19'2"
15					* 5.73	* 5.73	*5.98	4.68	*4.47	4.21	22'0"
10			*9.59	* 9.59	* 7.48	7.13	*6.66	4.56	*4.74	3.69	23'6"
5			*17.85	15.11	* 9.59	6.73	7.03	4.42	*5.16	3.54	23'10"
0(GND)	*4.90	*4.90	*14.05	*14.05	10.65	6.52	6.94	4.32	5.77	3.59	23'1"
-5	*10.37	*10.37	*19.43	14.58	12.28	7.38	6.87	4.27	6.30	3.92	21'1"
-10	* 16.98	* 16.98	*18.43	14.78	10.70	6.55			8.08	5.02	17'6"
-15	* 21.67	*21.67	*10.43	*10.43					*9.89	8.12	10'9"

- Note**
1. Ratings are based on SAE J1097
 2. The load point is a hook located on the back of the bucket.
 3. " * " Rated loads are based on hydraulic capacity.
 4. Rated loads do not exceed 87% of hyd . capacity or 75% of tipping capacity.

- ☐ : Rating over front
- ☐☐ : Rating over side or 360 degree
- 0 : Ground

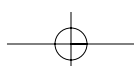

Option

Metric		Boom : 4.0m (13'1")		Arm : 1.9m (6'3")		Bucket : PCSA 0.58m ³ (CECE 0.50m ³)		Shoe : 600mm (2')		Unit : 1,000kg				
A (m)	B (m)	2		3		4		5		6		Max. Reach		
		□	□□	□	□□	□	□□	□	□□	□	□□	□	□□	A (m)
5								*2.99	*2.99			*2.37	*2.37	5.52
4								*3.26	*3.26	*2.84	*2.84	*2.43	*2.43	6.12
3						*4.36	*4.36	*3.87	3.74	*3.65	2.83	*2.58	2.51	6.48
2				*9.29	7.87	*5.91	5.07	*4.66	3.65	*4.06	2.78	*2.83	2.38	6.65
1				*6.99	*6.99	*7.30	4.92	*5.43	3.56	4.19	2.74	*3.23	2.36	6.64
0				*7.72	7.52	7.83	4.83	5.48	3.50	4.16	2.70	3.73	2.43	6.46
-1		*6.54	*6.54	*9.91	7.52	7.80	4.81	5.45	3.48	4.14	2.69	4.07	2.64	6.08
-2		*8.95	*8.95	*11.69	7.57	7.82	4.82	5.46	3.49			4.78	3.09	5.46
-3		*11.70	*11.70	*10.14	7.67	*7.17	4.88					*6.17	4.15	4.47

Feet

Unit : 1,000 lb

A (ft)		10'		15'		20'		Max. Reach		A (ft)
B (ft)		□	□□	□	□□	□	□□	□	□□	
		15								*5.26
10				*8.79	*8.79	*7.98	6.09	*5.66	5.55	21'22"
5		*20.20	16.56	*12.28	9.05	9.08	5.94	*6.61	5.20	21'87"
0		*17.72	16.15	13.88	8.78	8.95	5.83	8.22	5.37	21'18"
-5		*25.86	16.20	13.81	8.72			9.64	6.25	18'99"
-10		*21.72	16.48					*13.71	9.35	14'46"

Metric

Boom : 4.6m (15'1") Arm : 3.0m (9'8") Bucket : PCSA 0.40m³ (CECE 0.35m³) Shoe : 600mm (2') Unit : 1,000kg

A (m)		2		3		4		5		6		7		Max. Reach		A (m)
B (m)		□	□□	□	□□	□	□□	□	□□	□	□□	□	□□	□	□□	
		7								*2.11	*2.11					*1.85
6										*2.06	*2.06			*1.76	*1.76	6.40
5										*2.25	*2.25			*1.74	*1.74	6.99
4								*2.31	*2.31	*2.42	2.32	*2.20	1.79	*1.76	1.64	7.40
3						*2.91	*2.91	*2.78	*2.78	*2.70	2.27	*2.26	1.76	*1.82	1.53	7.65
2				*4.97	*4.97	*3.90	*3.90	*3.35	2.93	*3.04	2.21	2.72	1.72	*1.91	1.47	7.77
1				*6.79	6.08	*4.88	3.93	*3.94	2.82	*3.41	2.15	2.69	1.69	*2.03	1.45	7.76
0		*2.81	*2.81	*7.47	5.86	*5.69	3.80	4.43	2.74	3.35	2.10	2.65	1.66	*2.23	1.47	7.64
-1		*3.81	*3.81	*7.56	5.77	*6.19	3.72	4.37	2.69	3.31	2.06	2.64	1.64	2.48	1.55	7.37
-2		*5.22	*5.22	*8.73	5.74	6.20	3.68	4.35	2.67	3.30	2.05			2.71	1.69	6.95
-3		*6.98	*6.98	*8.36	5.77	6.21	3.69	4.36	2.67	3.31	2.06			3.11	1.94	6.34
-4		*9.36	*9.36	*7.51	5.85	*5.61	3.75	*4.28	2.71					3.92	2.44	5.47
-5		*8.25	*8.25	*5.76	*5.76	*4.33	3.89							*4.29	3.69	4.20

Feet

Unit : 1,000 lb

A (ft)		5'		10'		15'		20'		25'		Max. Reach		A (ft)
B (ft)		□	□□	□	□□	□	□□	□	□□	□	□□	□	□□	
		25						*4.40	*4.40					*4.24
20								*3.94	*3.94			*3.87	*3.87	21'2"
15								*5.31	4.83			*3.84	3.77	23'10"
10						*6.60	*6.60	*6.09	4.68			*4.03	3.35	25'2"
5				*15.72	15.47	*8.91	6.91	7.10	4.49	*4.41	3.21	*4.33	3.22	26'6"
0(GND)		*4.50	*4.50	*15.02	14.56	10.64	6.53	6.96	4.35			*4.91	3.25	24'10"
-5		*8.80	*8.80	*17.75	14.49	11.75	7.10	6.90	4.29			5.61	3.49	23'0"
-10		*14.33	*14.33	*19.57	14.58	10.52	6.42	7.44	4.64			6.68	4.28	19'9"
-15		*23.16	*23.16	*14.93	*14.93	*9.36	7.63					*8.97	6.11	14'2"

Note 1. Ratings are based on SAE J1097

2. The load point is a hook located on the back of the bucket.

3. " * " Rated loads are based on hydraulic capacity.

4. Rated loads do not exceed 87% of hyd . capacity or 75% of tipping capacity.

□ : Rating over front

□□ : Rating over side or 360 degree

0 : Ground

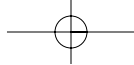

Lifting Capacities

Dozer Down

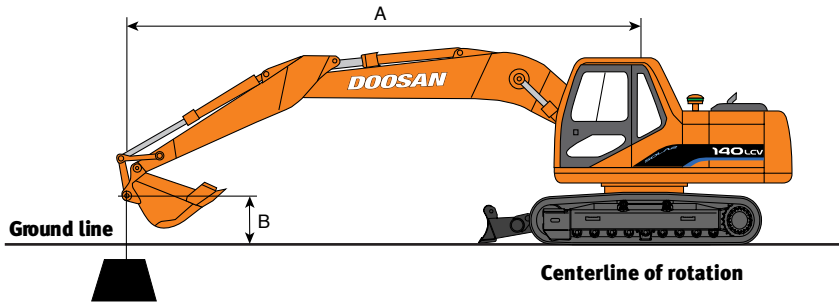

Boom : 4.6m (15'1")
Arm : 2.5m (8'2")
Bucket : PCSA 0.52 m³ (CECE 0.45 m³)
Shoe : 600mm (2')

Metric

Unit : 1,000 kg

A (m) \ B (m)	2		3		4		5		6		7		Max. Reach		A (m)
	☐	☐☐	☐	☐☐	☐	☐☐	☐	☐☐	☐	☐☐	☐	☐☐	☐	☐☐	
7													*2.23	*2.23	5.40
6									*2.55	2.36			*2.09	*2.09	6.39
5									*2.56	2.35	*2.20	1.79	*2.06	1.76	7.06
4							*2.82	*2.82	*2.80	2.31	*2.81	1.77	*2.10	1.56	7.52
3					*4.11	*4.11	*3.52	3.01	*3.20	2.25	*3.02	1.74	*2.18	1.44	7.81
2			*6.21	*6.21	*5.69	4.05	*4.35	2.89	*3.68	2.18	*3.30	1.70	*2.32	1.37	7.95
1			*3.11	*3.11	*7.05	3.86	*5.13	2.78	*4.15	2.11	*3.58	1.66	*2.52	1.35	7.94
0			*3.74	*3.74	*7.87	3.75	*5.72	2.70	*4.54	2.06	*3.82	1.63	*2.83	1.38	7.79
-1	*3.36	*3.36	*5.15	*5.15	*8.19	3.70	*6.04	2.66	*4.77	2.03	*3.94	1.61	*3.30	1.46	7.49
-2	*5.02	*5.02	*7.02	5.89	*8.09	3.70	*6.06	2.65	*4.78	2.02	*3.86	1.62	*3.84	1.61	7.01
-3	*6.93	*6.93	*9.54	5.96	*7.58	3.74	*5.75	2.67	*4.48	2.05			*4.12	1.90	6.32
-4	*9.35	*9.35	*9.01	6.08	*6.52	3.82	*4.88	2.73					*4.45	2.52	5.29

Feet

Unit : 1,000 lb

A (ft) \ B (ft)	10'		15'		20'		25'		Max. Reach		A (ft)
	☐	☐☐	☐	☐☐	☐	☐☐	☐	☐☐	☐	☐☐	
20					*5.36	5.05			*4.63	*4.63	20'69"
15					*5.84	5.02			*4.57	3.66	23'89"
10			*8.11	7.67	*6.96	4.84	*5.82	3.31	*4.79	3.17	25'59"
5	*8.95	*8.95	*11.68	7.14	*8.49	4.62	*7.16	3.22	*5.30	2.99	26'12"
0	*8.61	*8.61	*14.27	6.78	*9.81	4.44	*7.71	3.15	*6.24	3.04	25'56"
-5	*13.70	12.59	*15.11	6.66	*10.38	4.36			*8.06	3.37	23'83"
-10	*21.80	12.80	*14.13	6.73	*9.56	4.41			*9.11	4.24	20'59"
-15	*16.39	13.26							*10.32	7.28	14'64"

- Note
1. Ratings are based on SAE J1097
 2. The load point is a hook located on the back of the bucket.
 3. " * " Rated loads are based on hydraulic capacity.
 4. Rated loads do not exceed 87% of hyd . capacity or 75% of tipping capacity.

☐ : Rating over front
☐☐ : Rating over side or 360 degree
☐ : Ground

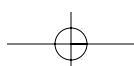

Dozer Up

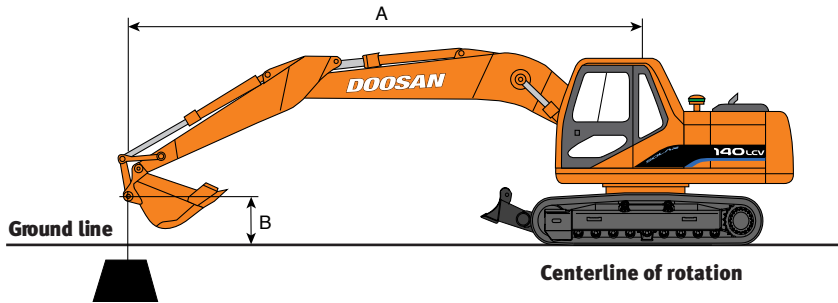

Boom : 4.6m (15'1")
Arm : 2.5m (8'2")
Bucket : PCSA 0.52 m²(CECE 0.45m²)
Shoe : 600mm (2')

Metric

Unit : 1,000 kg

A (m)	2		3		4		5		6		7		Max. Reach		A (m)
	☐	☐☐	☐	☐☐	☐	☐☐	☐	☐☐	☐	☐☐	☐	☐☐	☐	☐☐	
7													*2.23	*2.23	5.40
6									*2.55	2.36			*2.09	*2.09	6.39
5									*2.56	2.35	*2.20	1.79	*2.06	1.76	7.06
4							*2.82	*2.82	*2.80	2.31	2.80	1.77	*2.10	1.56	7.52
3					*4.11	*4.11	*3.52	3.01	*3.20	2.25	2.77	1.74	*2.18	1.44	7.81
2			*6.21	*6.21	*5.69	4.05	*4.35	2.89	3.48	2.18	2.72	1.70	2.22	1.37	7.95
1			*3.11	*3.11	6.49	3.86	4.52	2.78	3.40	2.11	2.68	1.66	2.20	1.35	7.94
0			*3.74	*3.74	6.36	3.75	4.43	2.70	3.35	2.06	2.65	1.63	2.25	1.38	7.79
-1	*3.36	*3.36	*5.15	*5.15	6.31	3.70	4.38	2.66	3.31	2.03	2.63	1.61	2.38	1.46	7.49
-2	*5.02	*5.02	*7.02	5.89	6.31	3.70	4.37	2.65	3.30	2.02	2.63	1.62	2.62	1.61	7.01
-3	*6.93	*6.93	*9.54	5.96	6.35	3.74	4.40	2.67	3.33	2.05			3.09	1.90	6.32
-4	*9.35	*9.35	*9.01	6.08	6.44	3.82	4.47	2.73					4.10	2.52	5.29

Feet

Unit : 1,000 lb

A (ft)	10'		15'		20'		25'		Max. Reach		A (ft)
	☐	☐☐	☐	☐☐	☐	☐☐	☐	☐☐	☐	☐☐	
20					*5.36	5.05			*4.63	*4.63	20'69"
15					*5.84	5.02			*4.57	3.66	23'89"
10			*8.11	7.67	*6.96	4.84	5.31	3.31	*4.79	3.17	25'59"
5	*8.95	*8.95	11.67	7.14	7.40	4.62	5.21	3.22	4.86	2.99	26'12"
0	*8.61	*8.61	11.26	6.78	7.20	4.44	5.13	3.15	4.96	3.04	25'56"
-5	*13.70	12.59	11.12	6.66	7.11	4.36			5.49	3.37	23'83"
-10	*21.80	12.80	11.20	6.73	7.17	4.41			6.88	4.24	20'59"
-15	*16.39	13.26							*10.32	7.28	14'64"

Note 1. Ratings are based on SAE J1097
 2. The load point is a hook located on the back of the bucket.
 3. " * " Rated loads are based on hydraulic capacity.
 4. Rated loads do not exceed 87% of hyd . capacity or 75% of tipping capacity.

☐ : Rating over front
 ☐☐ : Rating over side or 360 degree
 ☐ : Ground

**Seoul Office :**

Doosan Tower 27TH FL. 18-12, Euljiro-6Ga,
Jung-Gu, Seoul, Korea 100-730

Tel : +82-2-3398-8114

Fax : +82-2-3398-8117

www.doosaninfracore.com

Doosan Infracore Europe S.A.

1A, Rue Achille Degrâce, 7080 Frameries, Belgium
Tel : +32-65-61-3230 Fax : +32-65-67-7338

Doosan Infracore U.K., Ltd.

Doosan House, Unit 6, 3 Heol Y Gamlas, Parc Nantgarw, Nantgarw,
Cardiff. CF15 7QU, U.K.
Tel : +44-1443-84-2273 Fax : +44-1443-84-1933

Doosan Infracore Germany GmbH

Hans-Böckler strasse 29, D-40764, Langenfeld-Fuhrkamp, Germany
Tel : +49-2173-8509-18 Fax : +49-2173-8509-45

Doosan Infracore France

ZAC de La Clef Saint Pierre - Buroplus 2 1A Avenue Jean d'Alembert
78990 Elancourt, France
Tel : +33-(0)1-30-16-21-41 Fax : +33-(0)1-30-16-21-44

Doosan Infracore America Corporation

2905 Shawnee Industrial Way, Suwanee, Georgia 30024, U. S. A
Tel : +1-770-831-2200 Fax : +1-770-831-0480

Doosan Infracore (China) Co., Ltd.

#28, Wuzhishan Road, Eco. & Tech, Development Zone,
Yantai, Shandong, China
Tel : +86-535-638-2000 Fax : +86-535-638-2004

Doosan Infracore Xinjiang Machinery Co.,Ltd.

No. 178, Hetanbei Road, Wulumuqi, Xinjiang, China
Tel : +86-991-469-7217 Fax : +86-991-469-8641

Doosan Infracore Liaoning Machinery Co.,Ltd.

No.32 DongLing Road, DongLing District, ShenYang, Liaoning, China
Tel : +86-24-8841-1407 Fax : +86-24-8841-1404

Doosan Infracore South Africa (PTY)LTD.

60C Electron Road, Isando 1600, Johannesburg, South Africa
Tel : 27-11-974-2095 Fax : 27-11-974-2778

Doosan Infracore Middle East Center(Dubai)

P.O.Box 183127, Al-Serkal Building, Air Port Road,Dubai, U.A.E
Tel : +971-4-295-2781~2 Fax:+971-4-295-2783



PBP S140C500 0701

The illustrations do not necessary show the product in standard version.
All products and equipments are not available in all markets.
Materials and specifications are subjects to change without prior notice.