



Doosan Infracore
Construction Equipment

SOLAR180WV

Engine Power : DIN 6271,net 112kw(152ps)@2,100 rpm
SAE J 1349,net 112kw(150HP)@2,100 rpm
Operational Weight : Articulated Boom : 18,500kg (40,785 lb)
Mono Boom : 17,700kg (39,021 lb)
Bucket capacity(PCSA) : 0.34 ~ 0.91m³(0.44 ~ 1.19 cu.yd)



Performance

This hydraulic excavator is equipped with the air-to-water intercooler engine, which has the greatest power output in its class and excellent fuel economy. It assures outstanding workability, productivity, and efficiency through the e-EPOS system, the new and improved version of EPOS System. This will assure increase in operating capacity and decrease in fuel consumption.

Air to Water Intercooler Engine

Greatest power output and high-efficiency engine in its class.

Environment friendly, Green engine.

This machine is equipped with the engine meeting the U.S. EPA Tier-II Regulations and European stage-II Regulations requiring the reduction of harmful NOx, PM, HC, and CO emissions.

Compatible with the European New Noise Control Requirements

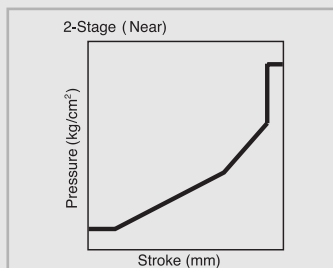
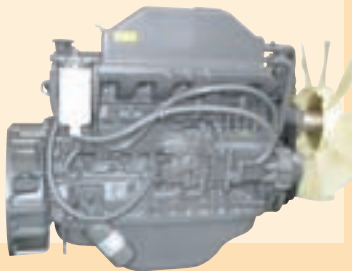

Improved maneuverability and control

New technologically advanced control valve and joystick valves have been installed to allow speedy, smooth and responsive control.



Joystick grip with 2 switches

Spare switches are installed on both joystick grips to control the additional attachment.



Excellent Reliability

Doosan's world-class center for product reliability performs sophisticated testing on all completed products, to ensure they meet or exceed market standards.

fan guard

A metal mesh guard has been installed the fan blade to prevent accidental bodily injury.



Heat shield panel for turbo charger

The heat shield guard has been installed over the turbo charger to prevent the operator from inadvertently touching the hot surfaces while checking the engine area.



Working Environment

Wide operator cabin space meet the ISO Standards and expanded all-round visibility. The low-noise, low-vibration type comfortable cabin provides the operator with safe and ergonomic operating environment.



The handle with tilting function

Because the handle with tilting function can be adjustable forward & backward according to operator's figure & location, It supply the best operation & minimize operator's fatigue in the optimum condition.



Increased foot space

Instruments, controls, and accessories have been ergonomically located in the cabin and 300mm seat slide has been achieved to provide ample space for operator's feet and legs.



Long wind shield wiper blade

Front visibility is further improved by using the lengthened wiper blade (wiper area increased 35% compared to previous machine.)

Large ceiling cover

The ceiling cover can be opened to confirm the bucket operation even at the maximum excavating height. (Visual range increased by 25% compared to previous machine.)

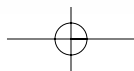



Cup holder

A folding style cup holder has been installed in the cabin allowing the operator to easily store a can or cup.



12V Spare Power Socket

This socket can be used for charging a cellular phone or powering a small 12V DC electrical device.

Fresh Air Type Air Conditioner

One touch selector switch for the air conditioner and heater output, featuring a multi-vent circulation system that allows for greater cooling / heating performance. Improved front window defroster system has been added to provide enhanced clarity and visibility during any working condition.

- Easy replaceable air filter.
- Larger cool air intake vents.
- Industry standard fresh air/recirculation control system incorporated.
- Modular electric fan condenser compartment.

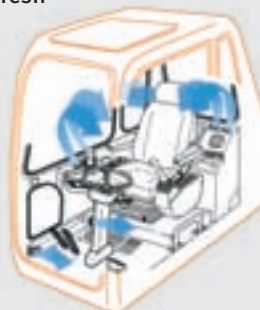

Low Vibration Cab Mounting System

By using a total isolating seal design (full sealing) outside noise has been drastically reduced to the levels comparable to that in a modern car. A viscous sealed mounting system has been incorporated, and the frame, cabin and seat have been designed to absorb major and minor vibrations, resulting in a significant decrease in vibration felt by the operator.

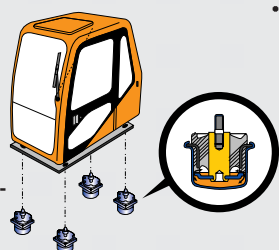

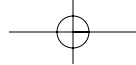

Maintenance

Quick and easy service checks, maximizing the excavator's life expectancy.

PC monitoring function (SMS)

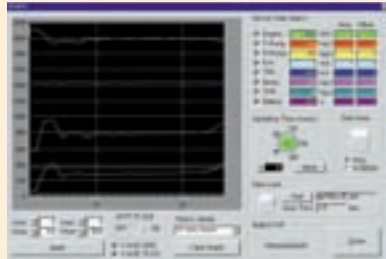

By connecting a laptop PC to the controller (e-EPOS controller) of the machine, data such as pump pressure and engine RPM can be displayed graphically. Also other various machine status data can be stored in memory and printed out using a printer.



Water separator

The transparent glass water separator is mounted at a location easily accessible from the ground allowing easy maintenance of the fuel system.



Large fuel tank

The fuel tank with 280 liter capacity has been mounted to reduce filling up interval.

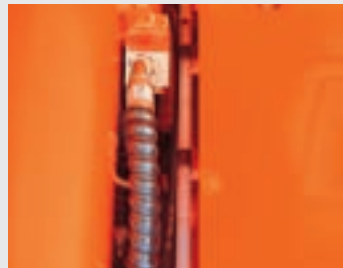

All range fuel level gauge

The fuel level gauge which show the fuel through all range is installed on the side of the fuel tank.



Engine oil drain valve

The engine oil drain valve with quick coupler provides fast and environmentally sound service-ability.



Electrical control access box

Pull-out style drawer for electrical control access box allows for easy service and maintenance.



Graphic display LCD Monitor panel

The information monitor panel displays both text and symbols for easy recognition of machine status and various other data



Simplified operation mode selection

The 3 work modes from the previous models have been reduced to digging and trenching modes for easy selection.

- **Digging Mode :**
General Excavating, Ground Leveling, Loading Dump Truck, allows for versatility.
- **Trenching Mode :**
trenching or excavating of side wall, operations which require heavy swing work.

FAILURE LOG
CODE: 12 N:001 0075Hr
Press up s/v open
PRV:▲ NXT:▼ 01/01

Self-diagnosis and fault history memory functions

Current faults and past faults history of the excavator control system are displayed and memorized on a real-time basis to enable correct diagnosis and quick repair.



02/05 [MO] 11:30A
ENG SPEED
2059
RPM

Real-time clock with day / date

The real-time clock displays date and day in easy to read format.

1. Fuel Filter
Hrs: 0232 Reset

Filter / oil operating hour display

The hours in use for 9 filters and oils can be displayed so that replacement intervals can be easily recognized.

LANGUAGE
Francais
Deutsch 4
SET: English

Multiple language display

The user menu can be displayed in multiple languages for the operator's convenience.

EPPR CURRENT
598
mA

Real-time machine data display

Displays 28 different machine status data and information such as pump delivery pressure and engine RPM.

Technical Data

* Engine

Model	DOOSAN DB58TIS
Type	Water-cooled, 4-cycle, 6-cylinder in line, direct injection chamber type diesel engine.

Rated flywheel horse power

DIN 6271, net	112 KW (152PS) at 2,100 rpm
SAE J1349, net	112 KW (150HP) at 2,100 rpm

Piston displacement 5,785cc (353cu.in)

Maximum torque 60 kgf.m (588 N.m,
434 lbf.ft) at 1,500 rpm

Bore and stroke 102mm × 118mm
(4.0" × 4.6")

Starting system 24V Electric motor

Batteries 2 × 12V × 100 AH

Auto-idle system : Engine rpm is reduced automatically to the low idle rpm after a lapse of approx. 4 seconds with all control levers in neutral position, thus saving energy and reducing noise.

Hydraulic system

Doosan's e-EPOS (Electronic Power Optimizing System) can achieve maximum job efficiency and reduce fuel consumption.

- 2-power mode working system.
- 2-Working mode selection system.
- Computer aided engine pump control.
- Hydraulic system assures fully independent and combined operations.
- Cross-sensing and fuel saving pump system.
- Auto idle system.
- 2 speed travel system for high traction force and travel speed.
- Travel motor brake torque-up system.
- Cruise travel system.

Main pumps 2 variable displacement
axial piston pumps.

Max. oil flow	2 × 164 ℓ/min (2 × 48.6 US gpm, 2 × 40.5 lmp gpm)
---------------------	---

Pilot pump Gear pump

Max. oil flow	19.4 ℓ/min (5.3 US gpm, 4.4 lmp gpm)
Pressure setting	39 bar (569 psi, 40 kgf / cm ²)

Brake pump Gear pump

Max. oil flow	17.2 ℓ/min (4.6 US gpm, 3.9 lmp gpm)
Pressure setting	157 bar (2,276 psi, 160 kgf / cm ²)

Steering pump Gear pump

Max. oil flow	47 ℓ/min (13.1 US gpm, 10.9 lmp gpm)
Pressure setting	193bar (2,417 psi, 200 kgf / cm ²)

Main relief valves

Boom/Arm/Bucket	343bar (4,978 psi, 350 kgf/cm ²)
Travel circuit	343 bar (4,978 psi, 350 kgf/cm ²)

Overload relief valves

Boom circuit	353 bar (5,120 psi, 360 kgf / cm ²)
Arm circuit	353 bar (5,120 psi, 360 kgf / cm ²)
Bucket circuit	353 bar (5,120 psi, 360 kgf / cm ²)

Swing motor relief valve

.....	275 bar (3,982 psi, 280kgf/cm ²)
-------	--

H Hydraulic cylinders

High-strength piston rods and tubes are used. Cylinder cushion mechanism is provided for boom, articulated boom. Arm and bucket cylinders to assure shock-free operation and extend life of cylinder.

Mono boom

Cylinders	Q'ty	Bore × Rod dia. × Stroke
Boom	2	115 × 80 × 1,195 mm (4.5" × 3.1" × 47")
Arm	1	125 × 90 × 1,450 mm (4.9" × 3.5" × 57")
Bucket	1	110 × 75 × 1,025 mm (4.3" × 3.0" × 40")

Articulated boom

Cylinders	Q'ty	Bore × Rod dia. × Stroke
Boom	2	115 × 80 × 1,032 mm (4.5" × 3.1" × 40.6")
Arti.Boom	1	200 × 130 × 639 mm (7.9" × 5.1" × 25.2")
Arm	1	125 × 90 × 1,450 mm (4.9" × 3.5" × 57")
Bucket	1	110 × 75 × 1,025mm (4.3" × 3.0" × 40")

Super-structure revolving frame

A deep, full-reinforced box section.
Heavy-gauge steel plates used for ruggedness.

Operator's cab

Independent, shock and noise-free roomy ISO standard operator's cab. 4 side safety glass windows give all-round visibility. Front window slides up and stores in the roof. Left and right side windows opens for ventilation. Fully adjustable reclining seat : fwd./rev. and up/down. Cab cooler is optionally available.

Noise Levels (dynamic value)

LwA External noise

Guaranteed Sound Power Level	103 dB (A) (2000/14/EC)
Measured Sound Power Level	101.7 dB (A) (2000/14/EC)

LpA Operator noise

76 dB (A) (ISO 6396)

Controls. 2 implement levers

Pilot pressure control type. Right lever is for boom and bucket control, left lever for swing and arm control. Left rear lever is for dozer and outrigger.

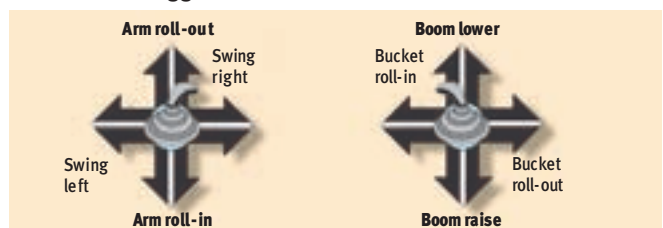



Swing mechanism

High-torque, axial piston motor with planetary reduction gear bathed in oil. Swing circle is a single-row, shear type ball bearing with induction-hardened internal gear. Internal gear and pinion immersed in lubricant. Swing reactionless valve is internally attached. Spring applied hydraulically released parking brake.

A swing lock clamps the superstructure for transportation.

- **Swing speed** 0 to 12 rpm(min⁻¹)
- **Rear swing radius** 2,450 mm(8'0")



Drive

Fully hydrostatic driven, 2 speed power shift transmission, variable displacement, high torque, axial piston motor, foot pedal controls provide smooth travel, hub reduction type front steering axle and rear rigid axle.

Travel speed 0 to 32 km/h (20 mph)

*A maximum speed restriction of 20 km/h is available as an option.

Maximum traction

- force 10,510 kgf (23,171 lbf)
- Gradeability for mono boom 34.3° (68.2%) continuous



Undercarriage

Heavy-duty frame, all-welded stress-relieved structure. Top grade materials used for toughness. Specially heat-treated connecting pins. 10.00-20-14PR(OTR) double tires with tire spacer. Front axle oscillating hydraulically.

Front outrigger and rear dozer as a standard. Front dozer as an option. Rear outrigger as an option.



Brake

Full sealed wet discs service brakes operated hydraulic and full sealed wet discs parking brake operated hydraulically.



Weight

Shipping weight-includes 10% fuel, 5,150mm(16'11") mono boom, 2,600mm(8'6") arm, 1,140mm(3'9") backhoe and rear dozer 17,700 kg (39,021 lb)

Major component weight

Mono boom

	kg	lb
Arm : 2,200mm(7'3")	537	1,184
Arm : 2,600mm(8'6")	584	1,287
Arm : 3,100mm(10'2")	639	1,409
Mono boom : 5,150mm(16'11")	1,081	2,383
Upper structure	5,050	11,133
Counter weight	2,700	5,952

Articulated boom

	kg	lb
Arm : 2,200mm(7'3")	537	1,184
Arm : 2,600mm(8'6")	584	1,287
upper boom : 4,050mm(13'3")	860	1,896
Lower boom : 1,900mm(6'3")	560	1,235
Upper structure	5,050	11,133
Counter weight	2,700	5,952



Service refill capacities

	Liters	US gal	Imp gal
Fuel tank	280	74.0	61.6
Cooling system	49	12.9	10.8
Lubrication	Liters	US gal	Imp gal
Engine oil	20.5	5.42	4.51
Swing drive	5	1.32	1.1
Final drive (each)	2	0.53	0.44
Hydraulic tank	205	54.2	45.1

Buckets

Capacity		Width		Weight	Recommendation		
PCSA, heaped	CECE, heaped	Without side cutters	With side cutters		2.2m (7'3")Arm	2.6m (8'6")Arm	3.1m (10'2")Arm
0.34 m ³ (0.44 cu.yd ³)	0.31m ³	650mm (26")	564mm (22")	415kg (915 lb)	A	A	A
0.45 m ³ (0.59 cu.yd ³)	0.4m ³	778mm (31")	692mm (27")	456kg (1,005 lb)	A	A	A
0.57 m ³ (0.75 cu.yd ³)	0.51m ³	928mm (37")	842mm (33")	518kg (1,142 lb)	A	A	A
0.7 m ³ (0.92 cu.yd ³)	0.61m ³	1,070mm (42")	984mm (39")	584kg (1,287 lb)	A	A	B
0.76 m ³ (1 cu.yd ³)	0.66m ³	1,140mm (45")	1,054mm (41")	611kg (1,347 lb)	A	A	B
0.81 m ³ (1.06 cu.yd ³)	0.7m ³	1,168mm (46")	1,058mm (42")	692kg (1,526 lb)	A	B	C
0.91 m ³ (1.19 cu.yd ³)	0.8m ³	1,290mm (51")	1,180mm (46")	733kg (1,616 lb)	B	B	C

- A. Suitable for materials with density of 2,000 kg/m³ (3,370 lb / cu.yd) or less
 B. Suitable for materials with density of 1,600 kg/m³ (2,700 lb / cu.yd) or less
 C. Suitable for materials with density of 1,100 kg/m³ (1,850 lb / cu.yd) or less

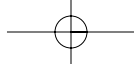

Undercarriage

Undercarriage with front outrigger and rear dozer

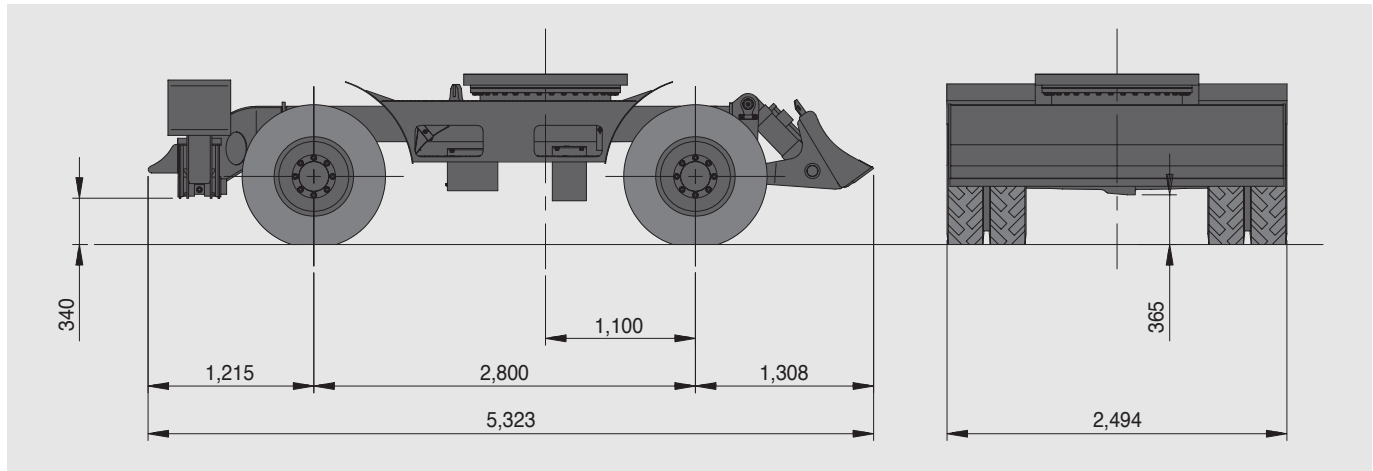

Undercarriage with front outrigger and rear cradle

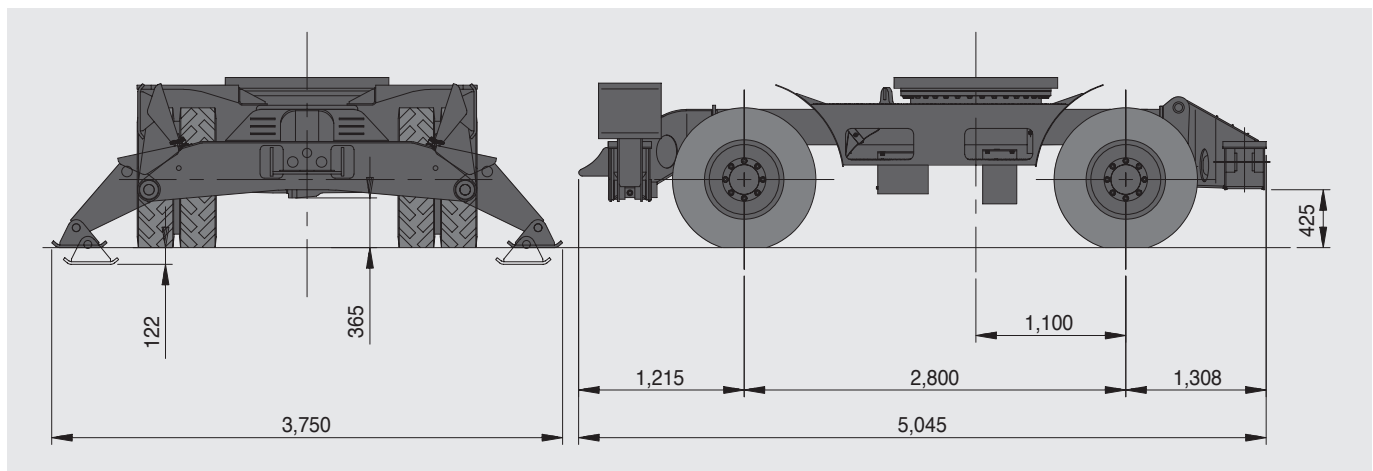

Undercarriage with front dozer and rear cradle

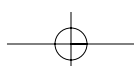
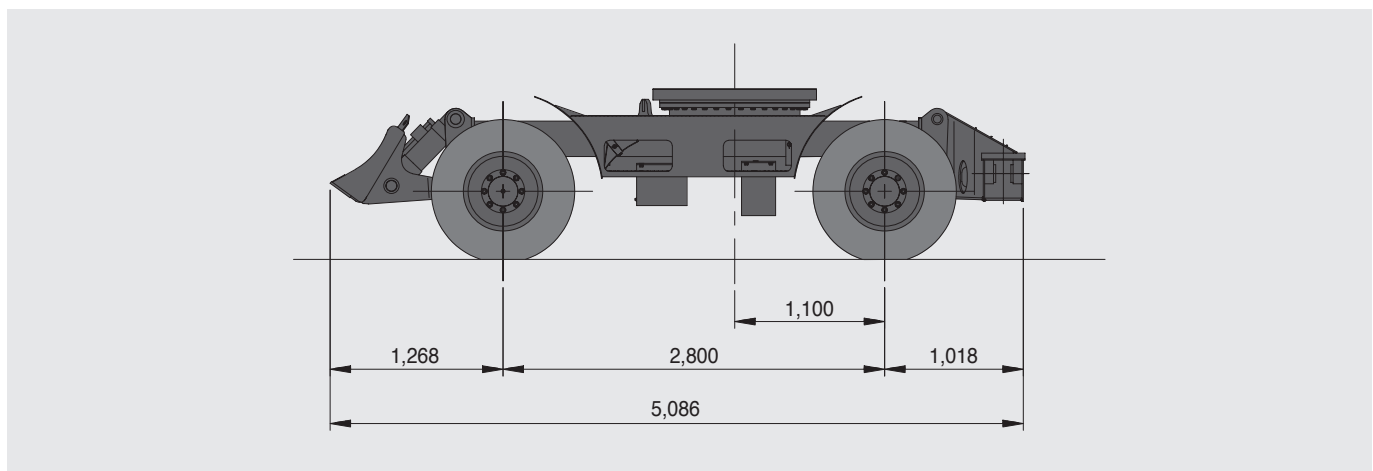

Standard equipment

Hydraulic system

- Boom and arm flow regeneration
- Boom and arm holding valves
- Swing anti-rebound valves
- Spare ports (valve)
- One-touch power boost

Cabin & Interior

- Viscous cab mounts
- All weather sound suppressed type cab
- Air conditioner
- Adjustable suspension seat with head rest and adjustable arm rest
- Pull-up type front window and removable lower front window
- Room light
- Intermittent windshield wiper
- Cigarette lighter and ashtray
- Cup holder
- Hot & cool box
- Graphic display monitor
- Fuel control dial
- AM/FM Radio and cassette player
- Remote radio ON/OFF switch
- 12V spare power socket
- Serial communication port for laptop PC interface
- Joystick lever with 2 switches

Safety

- Large handrails and step
- Punched metal anti-slip plates
- Seat belt
- Hydraulic safety lock lever
- Safety glass
- Hammer for emergency escape
- Right and left rearview mirrors
- Reverse travel alarm

Others

- Double element air cleaner
- Pre-cleaner
- Water separator
- Dust screen for radiator
- Engine overheat prevention system
- Engine restart prevention system
- Self-diagnostic system
- Alternator (24V, 60 amps)
- Electric horn
- Halogen working lights
(frame mounted 2, boom mounted 2)
- Track guards
- Double tire
- Rear dozer blade
- Front stabilizer

Optional equipment

Safety

- Boom and arm hose rupture protection valve
- Overload warning device
- Cabin Top/Front guard (ISO 10262, FOGS standard)
- Rotating beacon

Cabin & Interior

- Front lower guard
- Sunvisor
- Sun roof
- Joystick lever with 3 switches

Others

- Single tire
- Front dozer blade
- Rear stabilizer
- Piping for hammer (one way)
- Piping for rotation
- Double fuel filter
- Additional work lights on the cabin
(① 2 front lamps, ② 4 front and 2 rear lamps)
- Large capacity alternator (24V, 80A)
- Electric fuel supply pump



Boom and arm hose rupture protection valve



Sunvisor



Additional work lights on the cabin



Electric fuel supply pump



Rotating beacon

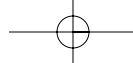

Dimensions & Working Ranges (Mono Boom)

Dimensions

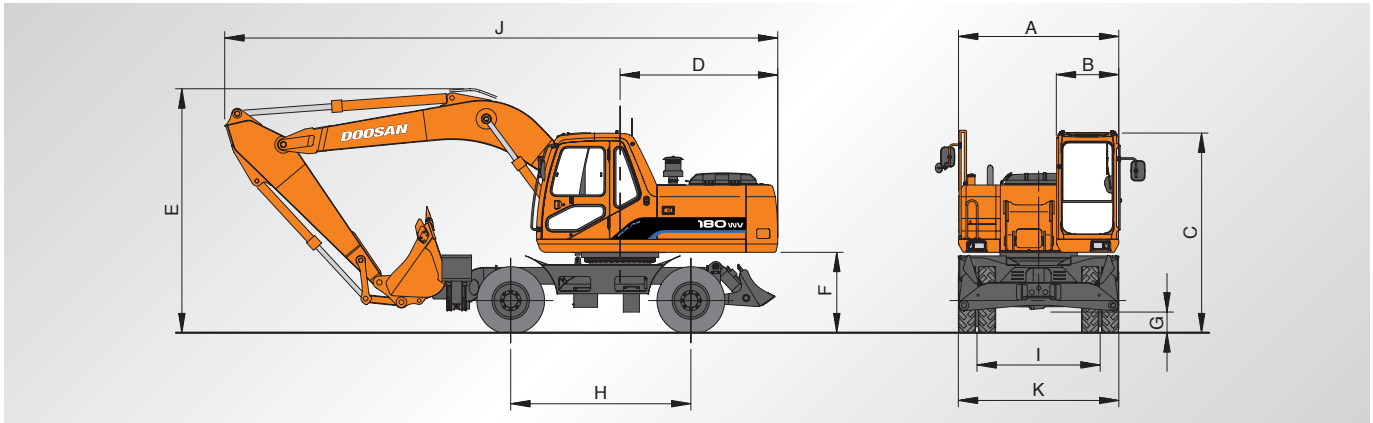

A Overall width of upper structure	2,490mm(8'2")
B Overall width of cab	960mm(3'2")
C Overall height of cab	3,103mm(10'2")
D Tail swing radius	2,450mm(8')
E Overall height of boom	3,795mm(12'5")
F Clearance under counterweight	1,249mm(4'1")
G Ground clearance	340mm(13")
H Wheel base	2,800mm(9'2")
I Tread	1,914mm(6'3")
J Overall length	8,595mm(28'2")
K Overall tire width with fender	
10.00-20-14PR Double tire (standard)	2,496 mm(8'2")

Digging forces(Maximum radial tooth forces)

	2.2m (7'3")Arm	2.6m (8'6")Arm	3.1m (10'2")Arm
Bucket digging force *	11,200 kgf 110 KN 24,690 lbf	11,200 kgf 110 KN 24,690 lbf	11,200 kgf 110 KN 24,690 lbf
Arm digging force *	10,600 kgf 104 KN 23,370 lbf	10,600 kgf 104 KN 23,370 lbf	10,600 kgf 104 KN 23,370 lbf

*At power boost

Working ranges

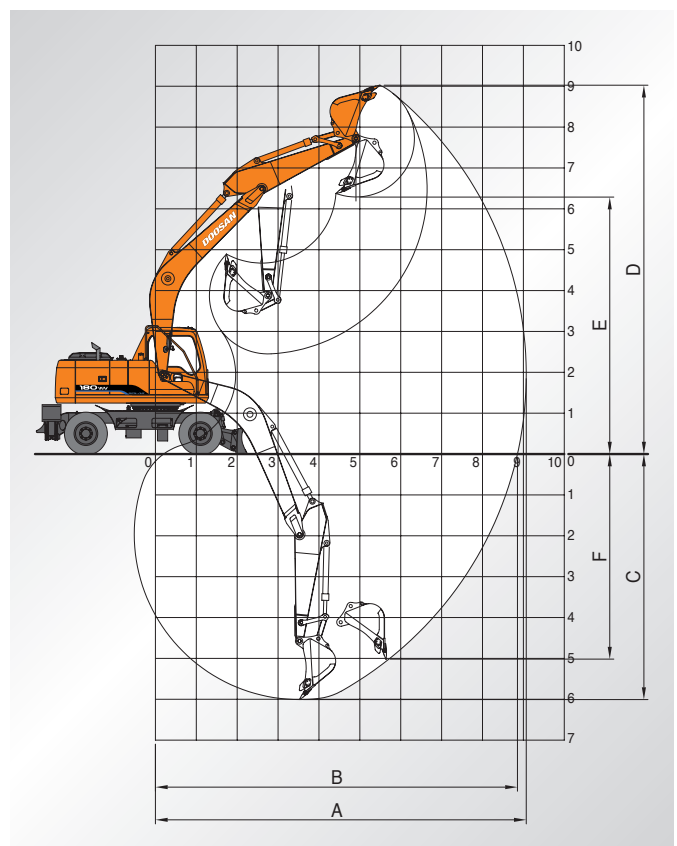

Boom length	Mono boom 5,150mm (16'11")		
Arm length	2,600mm (8'6")	2,200mm (7'3")	3,100mm (10'2")
A. Max. digging reach	9,071mm (29'9")	8,732mm (28'8")	9,509mm (31'2")
B. Max. digging reach at ground level	8,855mm (29'1")	8,507mm (30'5")	9,304mm (30'6")
C. Max. digging depth	6,006mm (19'8")	5,657mm (18'7")	6,506mm (21'4")
D. Max. digging height	9,026mm (29'7")	8,821mm (28'11")	9,197mm (30'2")
E. Max. dump height	6,289mm (20'8")	5,999mm (19'8")	6,464mm (21'2")
F. Vertical wall digging depth	5,019mm (16'6")	4,554mm (14'11")	5,494mm (18')

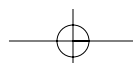

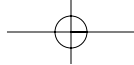

(Articulated Boom)

SOLAR 180WV

Dimensions

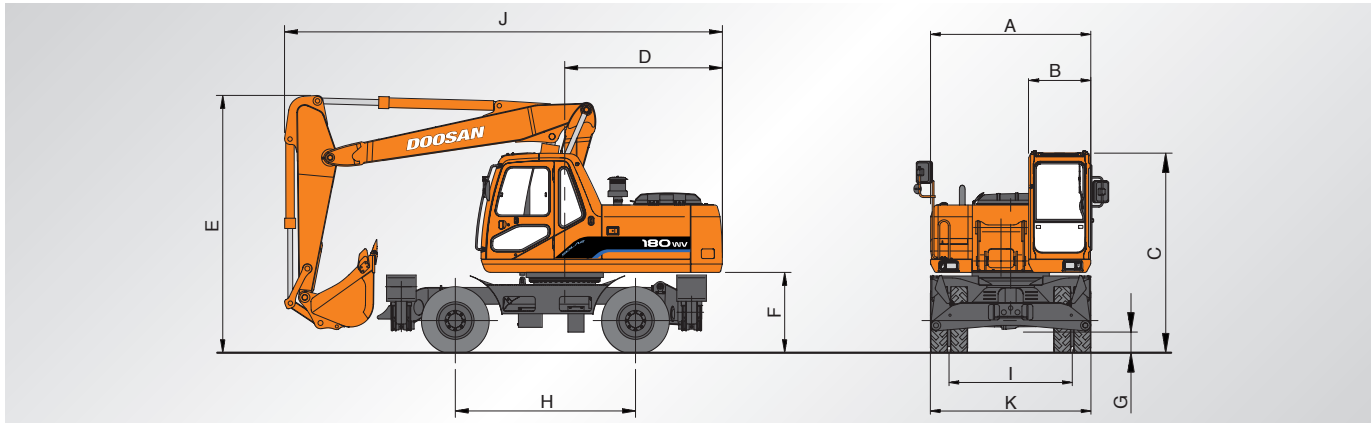

A Overall width of upper structure	2,490mm(8'2")
B Overall width of cab	960mm(3'2")
C Overall height of cab	3,103mm(10'2")
D Tail swing radius	2,450mm(8')
E Overall height of boom	4,000mm(13'1")
F Clearance under counterweight	1,249mm(4'1")
G Ground clearance	340mm(13")
H Wheel base	2,800mm(9'2")
I Tread	1,914mm(6'3")
J Overall length	6,805mm(22'4")
K Overall tire width with fender	
10.00-20-14PR Double tire (standard)	2,496 mm(8'2")

Working ranges

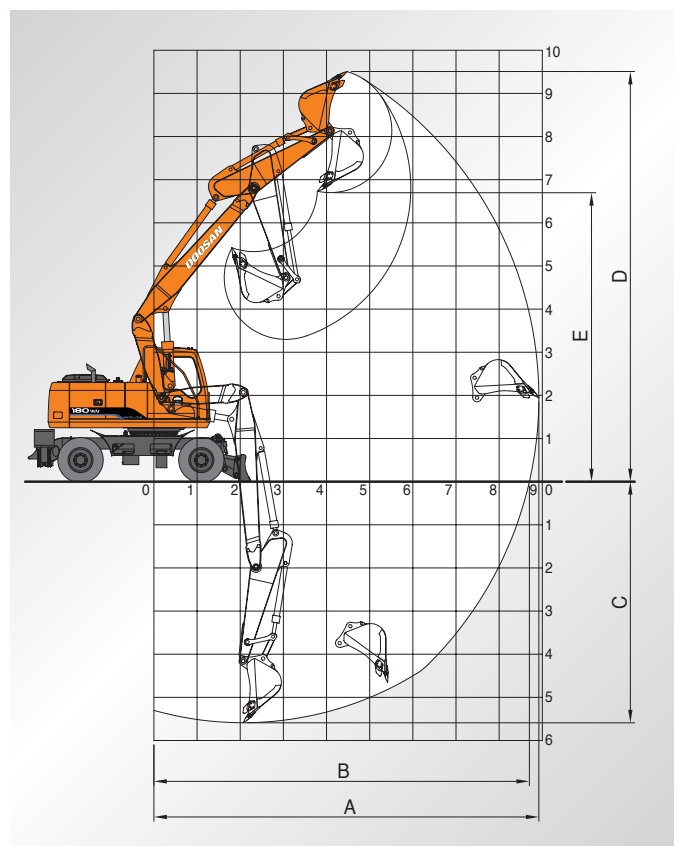

Digging forces (Maximum radial tooth forces)

	2.2m (7'3") Arm	2.6m (8'6") Arm
Bucket digging force *	11,200 kgf 110 KN 24,690 lbf	11,200 kgf 110 KN 24,690 lbf
Arm digging force *	10,600 kgf 104 KN 23,370 lbf	9,200 kgf 90 KN 20,280 lbf

*At power boost

Boom length	Articulated boom ; lower boom 1,900mm (6'3"), upper boom : 4,050mm (13'3")	
Arm length	2.200mm (7'3")	2.600mm (8'6")
A. Max. digging reach	8,921mm (29'3")	9,326mm (30'7")
B. Max. digging reach at ground level	8,701mm (28'6")	9,116mm (29'11")
C. Max. digging depth	5,591mm (18'4")	6,000mm (19'8")
D. Max. digging height	9,507mm (31'2")	9,826mm (32'3")
E. Max. dump height	6,697mm (21'11")	7,005mm (22'11")

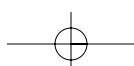

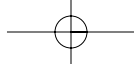

Lifting Capacities (Mono Boom)

Standard

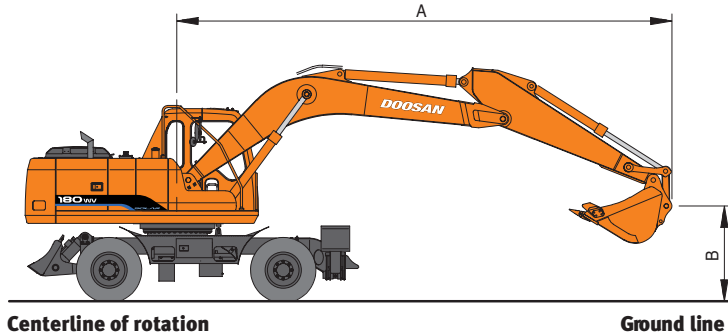

A : Load radius from centerline of rotation
B : Load point height

Boom : 5.15 (16'11")
Arm : 2.6 (8'6")
Bucket: PCSA 0.76m³ (CECEo.66m³)

Metric

Unit : 1,000 kg

A (m)	2		3		4		5		6		7		Max. Reach		A(m)
	□	□	□	□	□	□	□	□	□	□	□	□	□		
6									*3.51/*3.95	2.59/*3.95			*2.55/*2.83	2.14/*2.83	6.62
5									*3.68/*4.14	2.54/*4.14	*3.01/*3.33	1.90/*3.33	*2.59/*2.88	1.82/*2.88	7.15
4							*4.38/*4.91	3.36/*4.91	*4.00/*4.50	2.47/*4.50	3.66/*4.25	1.88/3.95	*2.70/*2.99	1.62/*2.99	7.51
3			*8.59/*9.57	7.09/*9.57	*6.22/*6.95	4.54/*6.95	*5.07/*5.69	3.20/*5.69	*4.41/*4.96	2.37/*4.96	3.60/*4.50	1.81/3.88	*2.86/*3.17	1.50/*3.17	7.72
2			*8.83/*9.78	6.50/*9.78	*7.43/*8.29	4.25/*8.29	*5.78/*6.47	3.04/*6.47	4.57/*5.44	2.27/4.91	3.53/*4.78	1.75/3.82	2.95/*3.42	1.43/3.20	7.79
1			*6.70/*7.44	6.19/*7.44	*8.30/*9.26	4.04/*9.26	6.03/*7.11	2.90/6.48	4.46/*5.85	2.19/4.81	3.47/*5.03	1.69/3.76	2.95/*3.78	1.42/3.20	7.73
0	*3.87/*4.34	*3.87/*4.34	*7.53/*8.35	6.08/*8.35	*8.72/*9.74	3.91/*9.37	5.91/*7.51	2.81/6.36	4.39/*6.12	2.12/4.74	3.43/*5.17	1.65/3.71	3.05/*4.31	1.46/3.30	7.54
-1	*6.00/*6.67	*6.00/*6.67	*9.39/*10.39	6.07/*10.39	*8.66/*9.78	3.86/*9.30	5.85/*7.62	2.76/8.30	4.35/*6.19	2.09/4.69	3.41/*5.14	1.63/3.69	3.26/*4.95	1.56/3.54	7.20
-2	*8.29/*9.17	*8.29/*9.17	*11.11/*12.40	6.11/*12.40	*8.41/*9.40	3.87/*9.31	5.84/*7.41	2.75/6.30	4.34/*5.98	2.08/4.69			3.67/*5.15	1.77/3.97	6.69
-3	*11.01/*12.14	*11.01/*12.14	*9.94/*11.11	6.21/*11.11	*7.65/*8.57	3.92/*8.57	5.89/*6.77	2.78/6.34					4.43/*5.36	2.14/4.78	5.96
-4	*10.83/*12.15	*10.83/*12.15	*8.11/*9.10	6.36/*9.10	*6.30/*7.08	4.02/*7.08							*4.89/*5.51	2.94/*5.51	4.93

Feet

Unit : 1,000 lb

A (ft)	10'		15'		20'		25'		Max. Reach		A(ft)
	□	□	□	□	□	□	□	□	□	□	
20'					*7.53/*8.35	5.54/*8.35			*5.61/*6.24	4.80/*6.24	21'52"
15'					*8.34/*9.38	5.39/*9.38			*5.80/*6.43	3.79/*6.43	24'02"
10'	*18.30/*20.38	15.33/*20.38	*11.99/*13.42	8.15/*13.42	*9.58/*10.76	5.10/*10.76	6.85/*7.77	3.39/7.42	*6.29/*6.96	3.31/*6.96	25'29"
5'	*16.81/*18.65	13.60/*18.65	*14.82/*16.57	7.48/*16.57	9.70/*12.26	4.79/10.45	6.70/*9.66	3.25/7.27	6.48/*7.89	3.13/7.03	25'51"
0	*17.21/*19.08	13.07/*19.08	15.17/*18.37	7.07/16.31	9.43/*13.25	4.56/10.18			6.71/*9.50	3.22/7.28	24'72"
-5'	*24.13/*26.65	13.07/*26.65	15.00/*18.39	6.94/16.14	9.32/*13.24	4.47/10.08			7.59/*11.14	3.65/6.23	22'81"
-10'	*21.47/*24.01	13.34/*24.01	*14.61/*16.39	7.04/16.27					9.88/*11.84	4.77/10.67	19'43"
-15'	*14.35/*16.17	13.96/*16.17							*10.70/*12.09	8.74/*12.09	13'48"

- Note**
1. Ratings are based on SAE J1097
 2. The load point is a hook located on the back of the bucket.
 3. *Rated loads are based on hydraulic capacity.
 4. Rated loads do not exceed 87% of hydraulic capacity or 75% of tipping capacity.

- : Rating over front
- : Rating over side or 360 degree
- 0 : Ground

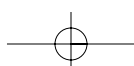

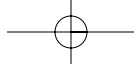

Lifting Capacities (Articulated Boom)

Standard

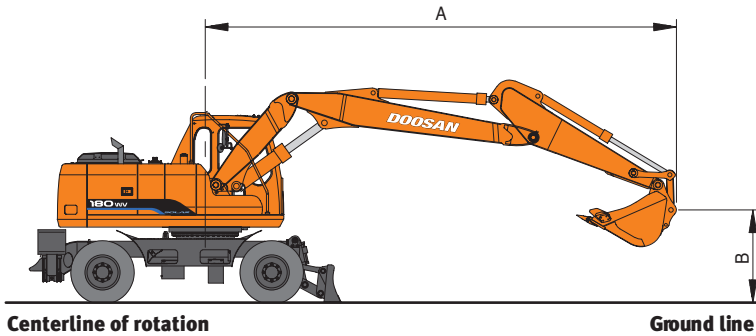

A : Load radius from centerline of rotation
 B : Load point height

Boom : 1.9m(6'3") + 4.05m(13'3")
Arm : 2.2 (7'3")
Bucket: PCSA 0.76m³ (CECEo.66m³)

Metric

Unit : 1,000 kg

A (m) B (m)	2		3		4		5		6		7		Max. Reach				
	□	□□	□	□□	□	□□	□	□□	□	□□	□	□□	□	□□	A(m)		
7							*2.28/*2.60	*2.28/*2.60							*2.68/*3.04	*2.68/*3.04	5.69
6							*2.38/*2.71	*2.38/*2.71	*2.73/*3.10	2.62/*3.10					*2.92/*3.31	2.27/*3.34	6.46
5							*2.81/*3.19	*2.81/*3.19	*2.93/*3.32	2.57/*3.32	*3.15/*3.56	1.92/*3.56			*3.15/*3.56	1.92/*3.56	7.00
4			*4.95/*5.56	*4.95/*5.56	*3.93/*4.43	*3.93/*4.43	*3.50/*3.96	3.37/*3.96	*3.33/*3.76	2.49/*3.76	*3.32/*3.76	1.88/*3.76			*3.38/*3.82	1.70/3.67	7.36
3					*5.46/*6.13	4.47/*6.13	*4.37/*4.92	3.19/*4.92	*3.86/*4.35	2.39/*4.35	*3.64/*4.11	1.83/3.95			3.20/*4.10	1.57/3.45	7.58
2					*6.99/*7.83	4.17/*7.83	*5.29/*5.94	3.02/*5.94	*4.45/5.01	2.28/4.97	3.60/*4.53	1.77/3.88			3.10/*4.40	1.50/3.35	7.65
1					*8.20/*9.17	3.98/*9.17	6.08/*6.86	2.89/6.53	4.52/5.64	2.19/4.87	3.54/*4.96	1.71/3.82			3.10/*4.75	1.49/3.36	7.59
0			*6.35/*7.05	6.04/*7.05	8.78/10.06	3.88/9.42	5.97/*7.60	2.80/6.42	4.45/6.19	2.13/4.80	3.49/*5.36	1.68/3.78			3.21/*5.15	1.53/3.47	7.39
-1	*5.95/*6.61	5.95/6.61	*9.06/*10.03	6.06/*10.03	8.75/10.59	3.86/9.39	5.93/*8.12	2.76/6.38	4.42/6.62	2.10/4.77	3.48/*5.67	1.67/3.76			3.45/*5.64	1.65/3.73	7.05
-2	*8.86/*9.79	8.86/9.79	*12.50/*13.79	6.13/*13.79	8.78/10.81	3.88/9.42	5.93/*8.40	2.77/6.39	4.43/6.86	2.11/4.78					3.89/*6.26	1.87/4.21	6.53
-3			*12.96/*14.42	6.25/*14.42	8.87/10.70	3.95/9.51	6.00/*8.39	2.82/6.45							4.76/*7.09	2.29/5.12	5.78

Feet

Unit : 1,000 lb

A (ft) B (ft)	10'		15'		20'		25'		Max. Reach				
	□	□□	□	□□	□	□□	□	□□	□	□□	A(ft)		
25'											*5.50/*6.24	*5.50/*6.24	16'55"
20'					*6.09/*6.91	5.60/*6.91					*6.39/*7.24	5.10/*7.24	20'98"
15'			*6.86/*7.76	*6.86/*7.76	*6.80/*7.70	5.44/*7.70					*7.16/*8.10	4.00/*8.10	23'54"
10'			*10.32/*11.60	8.09/*11.60	*8.38/*9.46	5.13/*9.46					7.07/*9.00	3.48/7.63	24'84"
5'			*14.01/*15.70	7.41/*15.70	9.83/*11.56	4.81/10.58	6.84/*10.06	3.30/7.40			6.81/*10.05	3.29/7.37	25'07"
0	*14.54/*16.15	12.97/*16.15	15.30/*18.69	7.04/16.43	9.57/*13.43	4.59/10.33					7.07/*11.35	3.38/7.66	24'26"
-5'	*24.26/*26.78	13.09/*26.78	15.20/*20.28	6.96/16.34	9.50/*14.68	4.53/10.25					8.04/*13.10	3.85/8.69	22'30"
-10'	*28.04/*31.21	13.44/*31.21	15.40/*20.39	7.12/16.54							10.62/*15.74	5.11/11.44	18'83"

Note 1. Ratings are based on SAE J1097
 2. The load point is a hook located on the back of the bucket.
 3. *Rated loads are based on hydraulic capacity.
 4. Rated loads do not exceed 87% of hydraulic capacity or 75% of tipping capacity.

□ : Rating over front
 □□ : Rating over side or 360 degree
 0 : Ground

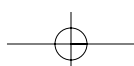

Option

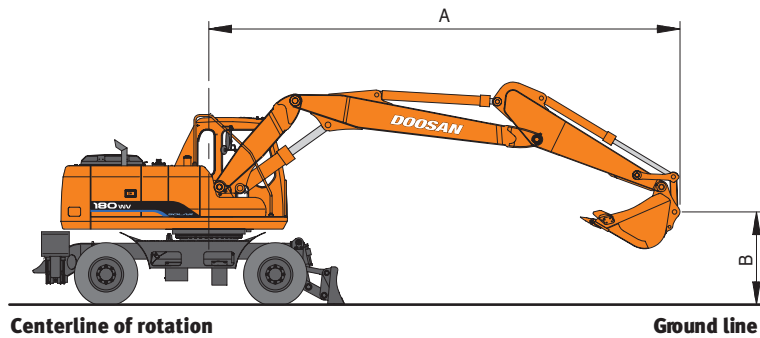

A : Load radius from centerline of rotation
B : Load point height

Boom : 1.9m(6'3")+4.05m(13'3")
Arm : 2.6 (8'6")
Bucket : PCSA 0.7m³ (CECEo.66m³)

Metric

Unit : 1,000 kg

A (m)	2		3		4		5		6		7		8		Max. Reach		A(m)	
	□	□	□	□	□	□	□	□	□	□	□	□	□	□	□			
8																*2.26/*2.57	*2.26/*2.57	5.27
7									*2.35/*2.68	*2.35/*2.68						*2.36/*2.62	*2.36/*2.62	6.26
6									*2.32/*2.65	*2.32/*2.65						*2.32/*2.58	1.97/*2.58	6.97
5							*2.37/*2.70	*2.37/*2.70	*2.56/*2.91	*2.56/*2.91	*2.77/*3.15	1.94/*3.15				*2.35/*2.60	1.69/*2.60	7.47
4					*3.28/*3.71	*3.28/*3.71	*3.06/*3.47	*3.06/*3.47	*2.98/*3.38	2.51/*3.38	*3.00/*3.41	1.90/*3.41				*2.42/*2.68	1.52/*2.68	7.81
3			*6.85/*7.67	*6.85/*7.67	*4.79/*5.39	4.57/*5.39	*3.94/*4.45	3.24/*4.45	*3.53/*4.00	2.40/*4.00	*3.35/*3.79	1.83/*3.79	*2.61/*2.89	1.41/*2.89		*2.54/*2.81	1.41/*2.81	8.02
2					*6.37/*7.14	4.26/*7.14	*4.89/*5.50	3.06/*5.50	*4.15/*4.68	2.30/*4.68	3.60/*4.24	1.77/3.88	2.87/*3.46	1.38/3.11		*2.72/*3.00	1.35/*3.00	8.09
1			*5.20/*5.80	*5.20/*5.80	*7.71/*8.63	4.04/*8.63	*5.78/*6.49	2.91/*6.49	4.53/*5.35	2.20/4.88	3.53/*4.71	1.71/3.82	2.84/*3.45	1.34/3.08		2.82/*3.26	1.34/*3.06	8.03
0			*6.32/*7.02	6.06/*7.02	*8.67/*9.69	3.91/*9.46	*5.99/*7.31	2.81/6.44	4.45/*5.95	2.13/4.80	3.48/*5.15	1.66/3.76				2.90/*3.64	1.37/3.15	7.84
-1	*5.29/*5.89	*5.29/*5.89	*8.23/*9.12	6.05/*9.12	8.75/*10.37	3.85/*9.39	5.92/*7.91	2.76/6.37	4.40/*6.44	2.09/4.75	3.45/*5.51	1.64/3.73				3.09/*4.20	1.46/3.35	7.52
-2	*7.55/*8.36	*7.55/8.36	*10.81/*11.94	6.09/*11.94	8.75/*10.74	3.86/*9.39	5.91/*8.30	2.74/6.36	4.39/*6.76	2.08/4.74	3.46/*5.42	1.64/3.74				3.43/*5.08	1.63/3.72	7.03
-3	*10.18/*11.24	*10.18/*11.24	*13.20/*14.68	6.19/*14.68	8.81/*10.78	3.90/*9.45	5.94/*8.42	2.77/6.39	4.43/*6.84	2.11/4.78						4.06/*6.40	1.94/4.38	6.35
-4					*8.95/*10.39	4.00/*9.59	6.05/*8.10	2.86/6.50								5.35/*7.38	2.56/5.76	5.39

Feet

Unit : 1,000 lb

A (ft)	10'		15'		20'		25'		Max. Reach		A(ft)	
	□	□	□	□	□	□	□	□	□	□		
25'										*5.21/*5.93	*5.21/*5.93	18'66"
20'						*5.18/*5.90	*5.18/*5.90			*5.12/5.69	4.43/*5.69	22'67"
15'				*5.74/*6.53	*5.74/*6.63	*6.02/*6.84	5.50/*6.84	*5.38/*5.96	3.56/*5.96	*5.23/*5.80	3.55/*5.80	25'06"
10'	*14.42/*16.16	*14.42/*16.16	*9.20/*10.37	8.23/*10.37	*7.67/*8.68	5.17/*8.68	7.00/*8.27	3.45/7.57		*5.59/*6.18	3.11/*6.18	26'28"
5'				*13.05/*14.65	7.51/*14.65	*9.66/*10.88	4.83/10.61	6.83/*9.44	3.29/7.39	6.19/*6.86	2.95/6.72	26'49"
0	*14.45/*16.05	13.03/*16.05	15.35/*17.98	7.07/16.49	9.56/*12.91	4.58/10.32	6.70/*10.65	3.17/7.26		6.40/*8.03	3.02/6.94	25'73"
-5'	*21.43/*23.69	13.05/*23.69	15.16/*19.94	6.93/16.30	9.44/*14.36	4.47/10.19				7.16/*10.15	3.39/7.75	23'90"
-10'	*28.57/*31.79	13.30/*31.79	15.27/*20.50	7.01/16.41	9.53/*14.79	4.55/10.28				9.04/*14.19	4.33/9.76	20'70"

Note 1. Ratings are based on SAE J1097
2. The load point is a hook located on the back of the bucket.
3. * Rated loads are based on hydraulic capacity.
4. Rated loads do not exceed 87% of hydraulic capacity or 75% of tipping capacity.

□ : Rating over front
□ : Rating over side or 360 degree
0 : Ground

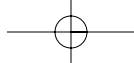

Option

Metric **Boom : 5.15 (16'11")** **Arm : 2.2m (7'3")** **Bucket : PCSA 0.81m³ (CECEo.71 m³)** **Unit : 1,000kg**

A (m) B (m)	2		3		4		5		6		7		Max. Reach		A(m)	
	□	□	□	□	□	□	□	□	□	□	□	□	□	□		
6									*3.80/*4.19	2.53/*4.19				*3.50/*3.87	2.44/*3.87	6.11
5							*4.15/*4.65	3.43/*4.65	*3.94/*4.43	2.49/*4.43				*3.59/*3.96	2.03/*3.96	6.68
4					*5.48/6.13	4.73/*6.13	*4.70/*5.26	3.29/*5.26	*4.23/*4.76	2.42/*4.76	3.62/*4.43	1.82/3.90		3.56/*4.15	1.78/3.84	7.06
3			*9.56/*10.65	6.80/*10.65	*6.68/7.47	4.41/*7.47	*5.36/*6.00	3.13/*6.00	*4.61/5.18	2.32/4.98	3.56/*4.68	1.77/3.85		3.32/*4.44	1.64/3.59	7.29
2					*7.78/8.69	4.13/*8.69	*6.00/*6.72	2.97/6.57	4.52/5.61	2.23/4.87	3.50/*4.92	1.71/3.78		3.22/*4.73	1.56/3.48	7.36
1			*5.98/*6.65	*5.98/*6.65	*8.49/9.48	3.94/*9.41	5.96/*7.27	2.84/6.41	4.42/5.96	2.15/4.77	3.45/*5.10	1.67/3.73		3.22/*4.90	1.55/3.49	7.30
0			*7.78/*8.62	6.00/*8.62	8.65/9.77	3.85/9.29	5.86/*7.56	2.76/6.31	4.36/6.16	2.09/4.71	3.41/*5.17	1.64/3.69		3.34/*5.09	1.60/3.62	7.09
-1	*6.85/*7.59	*6.85/*7.59	*10.42/*11.52	6.02/*11.52	*8.61/9.63	3.82/9.25	5.82/*7.56	2.73/6.27	4.33/6.13	2.07/4.68				3.62/*5.31	1.63/3.91	6.73
-2	*9.74/*10.59	*9.74/*10.75	*10.53/*11.76	6.09/*11.76	*8.12/9.09	3.85/*9.09	5.83/*7.20	2.74/6.29	4.34/5.77	2.08/4.69				4.15/*5.54	1.99/4.48	6.18
-3	*12.13/*13.58	*12.13/*13.58	*9.18/*10.28	6.22/*10.28	*7.18/8.06	3.92/*8.06	*5.65/*6.35	2.80/*6.35						*5.11/*5.75	2.50/5.63	5.39
-4	*9.02/*10.16	*9.02/*10.16	*7.06/*7.94	6.42/*7.94	*5.49/6.20	4.07/*6.20								*5.17/*5.84	3.77/*5.84	4.21

Feet

Unit : 1,000 lb

A(ft) B(ft)	10'		15'		20'		Max. Reach		A(ft)	
	□	□	□	□	□	□	□	□		
20'								*7.71/*8.52	5.49/*8.52	19'83"
15'				*10.03/*11.23	8.64/*11.23	*8.88/*9.98	5.28/*9.98	*8.06/*8.88	4.24/*8.88	22'53"
10'	*20.35/*22.67	14.71/*22.67		*12.75/*14.27	7.95/*14.27	9.95/*11.25	4.99/10.70	7.34/9.76	3.62/7.94	23'88"
5'				*15.31/*17.12	7.31/16.62	9.60/*12.57	4.70/10.35	7.06/10.59	3.42/7.65	24'11"
0(Ground)	*17.78/*19.70	12.88/*19.70		*15.03/*18.48	6.95/16.17	9.36/*13.34	4.50/10.12	7.36/11.22	3.53/7.98	23'27"
-5'	*23.90/*26.70	13.00/*26.70		*14.95/*18.03	6.88/16.09	9.31/*12.96	4.45/10.07	8.49/11.96	4.07/9.19	21'22"
-10'	*19.81/*22.19	13.36/*22.19		*13.70/*15.39	7.06/*15.39			*11.28/12.70	5.60/12.60	17'53"
-15'								*10.87/*12.34	*10.87/*12.34	10'51"

Metric

Boom : 5.15m (19'4") **Arm : 3.1m (10'2")** **Bucket : PCSA 0.50m³ (CECEo.51m³)**

Unit : 1,000kg

A (m) B (m)	2		3		4		5		6		7		8		Max. Reach		A(m)	
	□	□	□	□	□	□	□	□	□	□	□	□	□	□	□			
7																*2.19/*2.45	*2.19/*2.45	6.47
6											*2.47/*2.74	2.03/*2.74				*2.18/*2.42	1.94/*2.42	7.16
5									*3.36/*3.78	2.66/*3.78	*3.25/*3.60	2.01/*3.60				*2.21/*2.45	1.68/*2.45	7.65
4									*3.71/*4.17	2.58/*4.17	*3.54/*3.99	1.96/*3.99				*2.29/*2.54	1.51/*2.54	7.98
3					*5.57/*6.62	4.73/*6.22	*4.68/*5.25	3.33/*5.25	*4.15/*4.66	2.47/*4.66	3.69/*4.29	1.89/3.98	*2.90/*3.21	1.47/3.18		*2.41/*2.67	1.41/*2.67	8.18
2			*9.77/*10.89	6.78/*10.89	*6.87/*7.67	4.41/*7.67	*5.44/*6.09	3.15/*6.09	*4.62/*5.19	2.36/5.01	3.62/*4.61	1.82/3.90	2.89/*3.69	1.43/3.13		*2.59/*2.86	1.35/*2.86	8.25
1			*8.45/*9.35	6.33/*9.35	*7.92/*8.84	4.14/*8.84	*6.11/*6.84	2.98/6.58	4.54/*5.67	2.26/4.89	3.54/*4.91	1.76/3.82	2.85/*3.89	1.39/3.09		2.74/*3.12	1.33/2.97	8.19
0	*4.05/*4.52	*4.05/*4.52	*7.98/*8.84	6.12/*8.84	*8.56/*9.56	3.97/9.44	5.98/*7.37	2.86/6.43	4.45/*6.03	2.18/4.80	3.48/*5.13	1.70/3.76	2.82/*3.54	1.36/3.06		2.81/*3.50	1.36/3.05	8.01
-1	*5.62/*6.24	*5.62/*6.24	*9.07/*10.03	6.05/*10.03	8.68/*9.82	3.89/9.32	5.89/*7.63	2.79/6.34	4.39/*6.21	2.12/4.73	3.44/*5.22	1.67/3.73				2.98/*4.05	1.44/3.23	7.69
-2	*7.43/*8.22	*7.43/*8.22	*11.00/*12.14	6.06/*12.14	8.65/*9.67	3.86/9.29	5.85/*7.58	2.76/6.31	4.36/*6.16	2.10/4.71	3.43/*5.08	1.66/3.72				3.28/*4.86	1.59/3.55	7.22
-3	*9.60/*10.59	*9.60/*10.59	*10.73/*11.98	6.12/*11.98	*8.13/*9.09	3.89/*9.09	5.87/*7.18	2.78/6.32	4.38/*5.77	2.12/4.73						3.83/*5.08	1.86/4.14	6.55
-4	*12.33/*13.59	*12.33/*13.59	*9.25/*10.36	6.25/*10.36	*7.11/*7.97	3.97/*7.97	*5.56/*6.25	2.84/*6.25								*4.71/*5.30	2.39/5.30	5.63
-5	*9.23/*10.39	*9.23/*10.39	*6.89/*7.75	6.47/*7.75	*5.24/*5.91	4.13/*5.91										*4.81/*5.43	3.73/*5.43	4.28

Feet

Unit : 1,000 lb

A(ft) B(ft)	10'		15'		20'		25'		Max. Reach		A(ft)	
	□	□	□	□	□	□	□	□	□	□		
20'										*4.79/*5.34	4.34/*5.34	23'29"
15'					*7.69/*8.64	5.64/*8.64	*5.86/*6.49	3.71/6.49		*4.93/*5.48	3.52/*5.48	25'62"
10'				*10.93/*12.23	8.48/*12.23	*9.02/*10.13	5.32/*10.13	7.05/*8.94	3.57/7.61	*5.30/*5.87	3.11/*5.87	26'81"
5'	*23.07/*25.70	14.06/*25.70		*14.02/*15.68	7.73/*15.68	9.89/11.79	4.68/10.64	6.86/*9.83	3.40/7.42	*5.94/*6.58	2.94/6.54	27'02"
0(Ground)	*18.27/*20.22	13.16/*20.22		*15.32/*18.00	7.20/16.46	9.56/13.06	4.68/10.31	6.71/*10.37	3.26/7.27	6.20/*7.71	3.00/6.73	26'27"
-5'	*22.59/*24.94	12.99/*24.94		*15.04/*18.62	6.98/16.18	9.39/13.46	4.54/10.14			6.87/*9.82	3.32/7.44	24'48"
-10'	*23.18/*25.89	13.16/*25.89		*15.07/*17.37	7.01/16.21	9.42/12.38	4.57/10.18			8.52/*11.22	4.15/9.21	21'38"
-15'	*17.51/*19.65	13.67/*19.65		*11.73/*13.21	7.30/*13.21					*10.56/*11.91	6.54/*11.91	16'19"

- Note**
1. Ratings are based on SAE J1097
 2. The load point is a hook located on the back of the bucket.
 3. *Rated loads are based on hydraulic capacity.
 4. Rated loads do not exceed 87% of hyd . capacity or 75% of tipping capacity.

- : Rating over front
- : Rating over side or 360 degree
- 0 : Ground

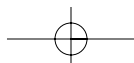

**Seoul Office :**

Doosan Tower 27TH FL. 18-12, Euljiro-6Ga,
Jung-Gu, Seoul, Korea 100-730

Tel : +82-2-3398-8114

Fax : +82-2-3398-8117

www.doosaninfracore.com

Doosan Infracore Europe S.A.

1A, Rue Achille Degrâce, 7080 Frameries, Belgium
Tel : +32-65-61-3230 Fax : +32-65-67-7338

Doosan Infracore U.K., Ltd.

Doosan House, Unit 6, 3 Heol Y Gamlas, Parc Nantgarw, Nantgarw,
Cardiff. CF15 7QU, U.K.
Tel : +44-1443-84-2273 Fax : +44-1443-84-1933

Doosan Infracore Germany GmbH

Hans-Böckler strasse 29, D-40764, Langenfeld-Fuhrkamp, Germany
Tel : +49-2173-8509-18 Fax : +49-2173-8509-45

Doosan Infracore France

ZAC de La Clef Saint Pierre - Buroplus 2 1A Avenue Jean d'Alembert
78990 Elancourt, France
Tel : +33-(0)1-30-16-21-41 Fax : +33-(0)1-30-16-21-44

Doosan Infracore America Corporation

2905 Shawnee Industrial Way, Suwanee, Georgia 30024, U. S. A
Tel : +1-770-831-2200 Fax : +1-770-831-0480

Doosan Infracore (China) Co., Ltd.

#28, Wuzhishan Road, Eco. & Tech, Development Zone,
Yantai, Shandong, China
Tel : +86-535-638-2000 Fax : +86-535-638-2004

Doosan Infracore Xinjiang Machinery Co.,Ltd.

No. 178, Hetanbei Road, Wulumuqi, Xinjiang, China
Tel : +86-991-469-7217 Fax : +86-991-469-8641

Doosan Infracore Liaoning Machinery Co.,Ltd.

No.32 DongLing Road, DongLing District, ShenYang, Liaoning, China
Tel : +86-24-8841-1407 Fax : +86-24-8841-1404

Doosan Infracore South Africa (PTY)LTD.

60C Electron Road, Isando 1600, Johannesburg, South Africa
Tel : 27-11-974-2095 Fax : 27-11-974-2778

Doosan Infracore Middle East Center(Dubai)

P.O.Box 183127, Al-Serkal Building, Air Port Road,Dubai, U.A.E
Tel : +971-4-295-2781~2 Fax:+971-4-295-2783



PBP S180W500 0701

The illustrations do not necessary show the product in standard version.
All products and equipments are not available in all markets.
Materials and specifications are subjects to change without prior notice.