

INSTRUCTIONS



SUMMIT
EST. 1981
TREESTANDS

Climbing Treestands
Summit Razor SS / Summit OpenShot
PN 81068
PN 81079

WARNING

You must fully read, understand and follow these warnings and instructions (written and video)! Failure to follow these instructions may cause serious injury or death!!

- **WHEN HUNTING FROM A TREESTAND FALLS CAUSING INJURY OR DEATH CAN OCCUR ANY TIME AFTER LEAVING THE GROUND!** FOR THOSE REASONS ALWAYS WEAR A FALL ARREST SYSTEM (FAS) COMPRISING A FULL BODY HARNESS AT ALL TIMES AFTER LEAVING THE GROUND. YOU MUST STAY CONNECTED AT ALL TIMES AFTER LEAVING THE GROUND WHILE USING ANY ELEVATED HUNTING PLATFORM. SINGLE SAFETY BELTS AND CHEST HARNESSES ARE NO LONGER ALLOWED AND SHOULD NEVER BE USED. IF YOU ARE NOT WEARING A FULL BODY HARNESS THAT IS PROTECTING YOU FROM A FALL, DO NOT LEAVE THE GROUND!
- READ AND UNDERSTAND ALL OF THE MANUFACTURER'S WARNINGS AND INSTRUCTIONS AND USE ALL SAFETY DEVICES PROVIDED. CONTACT SUMMIT TREESTANDS FOR ANY QUESTIONS. FAILURE TO DO SO COULD RESULT IN INJURY OR DEATH!
- A SIGNAL DEVICE SUCH A MOBILE PHONE, RADIO, WHISTLE, SIGNAL FLARE OR PERSONAL LOCATOR DEVICE (PLD) MUST BE ON YOUR PERSON AND READILY AVAILABLE AT ALL TIMES! ALWAYS INFORM SOMEONE OF YOUR HUNTING LOCATION, WHERE THE TREESTAND WILL BE LOCATED AND THE EXPECTED DURATION OF THE HUNT!
- DO NOT USE ANY TREESTAND UNLESS YOU ARE IN GOOD PHYSICAL SHAPE AND HAVE NO PHYSICAL LIMITATIONS OR MEDICAL CONDITIONS WHICH MAY PREVENT YOU FROM SAFELY USING THIS PRODUCT. ALWAYS CONSULT A PHYSICIAN IF YOU HAVE ANY QUESTIONS ABOUT YOUR PHYSICAL ABILITY TO USE THIS PRODUCT.
- NEVER USE A TREESTAND WHILE TAKING DRUGS, ALCOHOL OR CERTAIN PRESCRIPTION DRUGS! ALWAYS CONSULT A PHYSICIAN IF YOU HAVE ANY QUESTION ABOUT TAKING SPECIFIC MEDICATIONS AND USING THIS PRODUCT!
- NEVER USE A TREESTAND DURING INCLEMENT WEATHER SUCH AS RAIN, LIGHTNING, WINDSTORMS OR ICY CONDITIONS! END YOUR HUNT AND RETURN TO THE GROUND IF ANY OF THESE INCLEMENT CONDITIONS ARISE.
- NEVER USE A TREESTAND WHEN FEELING ILL, NAUSEOUS, DROWSY OR DIZZY!
- BE WELL RESTED AND NEVER HURRY. HURRYING CAUSES ACCIDENTS!
- NEVER USE A TREESTAND ON A DEAD, LEANING, DISEASED, LOOSE BARKED TREE, ON A UTILITY POLE OR ON TREES THAT HAVE ANY OBSTRUCTIONS THAT MAY LIMIT TREESTAND USE! NEVER RELY ON A TREE BRANCH FOR SUPPORT!
- NEVER JUMP OR BOUNCE ON A TREESTAND TO SECURE IT TO THE TREE!
- PULL UP A BOW, BACKPACK, FIREARM OR OTHER EQUIPMENT ONLY AFTER BEING SECURE IN THE TREESTAND. FIREARMS MUST BE PULLED UP UNLOADED, CHAMBER OPEN AND MUZZLE DOWN!
- UNDER NO CIRCUMSTANCE SHOULD YOU EVER RELEASE THE CABLE FROM THE PLATFORM OR SEAT CLIMBER TO MAKE ADJUSTMENTS ONCE YOU ARE OFF THE GROUND!!!
- NEVER MODIFY YOUR STAND IN ANY WAY BY MAKING REPAIRS, REPLACING PARTS, OR ALTERING, ADDING OR ATTACHING ANYTHING TO IT EXCEPT IF EXPLICITLY AUTHORIZED IN WRITING BY THE MANUFACTURER!
- PRACTICE INSTALLING, ADJUSTING AND USING YOUR TREESTAND AT GROUND LEVEL PRIOR TO USING IT AT ELEVATED POSITIONS!
- INSTRUCTIONS (WRITTEN AND VIDEO) SHOULD BE KEPT IN A SAFE PLACE AND REVIEWED AT LEAST ANNUALLY. IT IS THE RESPONSIBILITY OF THE TREESTAND OWNER TO FURNISH THE COMPLETE INSTRUCTIONS TO ANY PERSON WHO BORROWS OR PURCHASES THE TREESTAND! THIS SUMMIT TREESTAND IS DESIGNED TO BE USED AS A COMPLETE SYSTEM - NEVER LOAN OR SELL ONLY A PORTION OF THE CLIMBING TREESTAND SYSTEM.
- BEFORE EACH USE OF YOUR SUMMIT TREESTAND, ALWAYS INSPECT THE TREESTAND AND HARNESS FOR ANY DAMAGE, CRACKS, TEARS, CABLE WEAR OR ABRASION THAT MAY HAVE OCCURRED IN TRANSPORTING / STORING YOUR TREESTAND. DO NOT USE IF ANY DAMAGE IS FOUND! CONTACT CUSTOMER SERVICE FOR THE APPROPRIATE REPAIR / REPLACEMENT PROCEDURE!
- DO NOT LEAVE YOUR TREESTAND OUTDOORS OR STORE IT OUTDOORS WHEN IT IS NOT BEING USED! ANY STAND TUBING THAT IS ALLOWED TO FILL WITH RAINWATER AND FREEZE WILL RUPTURE OR BURST - DO NOT USE YOUR TREESTAND IF THIS OCCURS!

You **MUST** also view the enclosed DVD **BEFORE** using your new treestand!!

WEIGHT LIMITS **300 LBS. TOTAL***

RAZOR - 81068

OPENSOT - 81079

DO NOT EXCEED THIS LIMIT!
(* Includes all gear)

Stand minimum and maximum
tree size: 8-20" diameter

1 INDEX

GENERAL WARNINGS AND PRECAUTIONS, STAND WEIGHT LIMITS
 SECTION 1 - INDEX
 SECTION 2a - RAZOR PARTS LIST
 SECTION 2b - OPENSLOT PARTS LIST
 SECTION 3 - TOOLS REQUIRED
 SECTION 4a - RAZOR SEAT CLIMBER ASSEMBLY
 SECTION 4b - OPENSLOT SEAT CLIMBER ASSEMBLY
 SECTION 4c - RAZOR / OPENSLOT SHARED ASSEMBLY STEPS
 SECTION 5 - SETUP AND USE
 SECTION 6 - TIPS
 SECTION 7 - MAINTENANCE AND CARE
 SECTION 8 - HARNESS SUSPENSION INFORMATION
 SECTION 9 - LIMITED WARRANTY INFORMATION

PG 1
 PG 2
 PG 2
 PG 3
 PG 3
 PG 3-5
 PG 5
 PG 6
 PG 6-11
 PG 11
 PG 12
 PG 12
 PG 12

2a RAZOR PARTS LIST

Please call 256-353-0634 or visit <http://www.summitstands.com/contactus/> if you have any questions, if you need replacement parts, if you have any missing parts or if the included DVD does not play.

RAZOR BOX CONTENTS

PN	DESCRIPTION	QTY
41100	PLATFORM	1
41106	RAZOR SEAT CLIMBER	1
70200	RAZOR FOAM SEAT	1
40130	RAZOR SEAT BAR	1
30700	CLIMBING CABLE	2
72013	ACCESSORY PACKET	1

72013 - ACCESSORY PACKET CONTENTS

PN	DESCRIPTION	QTY
10534	STIRRUP	2
30341	STIRRUP BUNGEE WITH HOOK	1
21070	SITRRUP HARDWARE (2 BOLTS, 2 NUTS)	1
30283	1" CAMO BACKPACK STRAP	2
40274	2" CAMO BACKPACK STRAP W/ BUCKLE	1
30285	GREEN TOURNIQUET STRAP W/ BUCKLE	1
30536	STAND UMBILICAL ROPE	1
10656	IN LINE CABLE TIE	6
70224	18" CAMO FRONT PAD	1
70223	12" CAMO ARM PAD	2
83054	SUMMIT 4 POINT SAFETY HARNESS W/ ATTACHED SRS STRAP HARNESS SAFETY STRAP	1
18029	WRITTEN HARNESS INSTRUCTIONS	1
18007	WARRANTY CARD	1
18030	2010 SAFETY AND INSTRUCTIONAL DVD	1
21068	CLIMBING BAR HARDWARE PACKET	1
10466	SUPPORT STRUT / KEYHOLE BRACKET	2

21068 - CLIMBING BAR HARDWARE

PN	DESCRIPTION	QTY
10606	2" BOLT, 1/4x20	2
10689	1 3/4" SHOULDER BOLT, 1/4x20	2
10605	3/4" BOLT, 1/4x20	2
10612	LOCK NUT, 1/4x20	2
10688	15/16" TALL NYLON SPACER	2
10640	LONG SHANK BUSHING	4
10641	SHORT SHANK BUSHING	8
10693	1/4" TALL METAL BUSHING	2

Summit products are manufactured under one or more of the following US Patents: 5,937,969; 5,971,104; 5,975,242; 5,979,603; 6,125,966; 6,182,792; 6,397,973; D,417,011; D,420,147; D,575,411

Summit Bucksteps are Patent Pending



2b OPENSHOT PARTS LIST

Please call 256-353-0634 or visit <http://www.summitstands.com/contactus/> if you have any questions, if you need replacement parts, if you have any missing parts or if the included DVD does not play.

OPENSHOT BOX CONTENTS

PN	DESCRIPTION	QTY
40101	PLATFORM	1
51109	OPENSHOT CLIMBER	1
70210	OPENSHOT FOAM SEAT	1
40155	OPENSHOT SEAT BAR	1
30700	CLIMBING CABLE	2
72012	ACCESSORY PACKET	1

72012 - ACCESSORY PACKET CONTENTS

PN	DESCRIPTION	QTY
10534	STIRRUP	2
30341	STIRRUP BUNGEE WITH HOOK	1
21070	SITRRUP HARDWARE (2 BOLTS, 2 NUTS)	1
30283	1" CAMO BACKPACK STRAP	2
40274	2" CAMO BACKPACK STRAP W/ BUCKLE	1
30285	GREEN TOURNIQUET STRAP W/ BUCKLE	1
30536	STAND UMBILICAL ROPE	1
83054	SUMMIT 4 POINT SAFETY HARNESS W/ ATTACHED SRS STRAP HARNESS SAFETY STRAP	1
18029	WRITTEN HARNESS INSTRUCTIONS	1
18007	WARRANTY CARD	1
18030	2010 SAFETY AND INSTRUCTIONAL DVD	1
21079	HARDWARE PACKET	1

21079 - OPENSHOT HARDWARE KIT

PN	DESCRIPTION	QTY
10600	1 1/2" BOLT, 1/4x20	2
10612	LOCK NUT, 1/4x20	2
10640	LONG SHANK BUSHING	4
10641	SHORT SHANK BUSHING	2

3 TOOLS REQUIRED

Tools

- 7/16" Wrenches and / or Socket / Ratchet -
- Knife or Snips

Use

Climbing Bar / Seat Attachment Bolts / Nuts
Cable Tie Trimming

4a RAZOR SEAT CLIMBER ASSEMBLY

CLIMBING BAR

1. Place 4 long shank bushings into the four holes in the ends of the supplied Razor Seat Bar as shown in **figure 1**.

2. Place two short shank bushings in the holes on the outside of the U-Bracket attached to the climber portion of the stand - shown in **figure 2**. Repeat for other side.

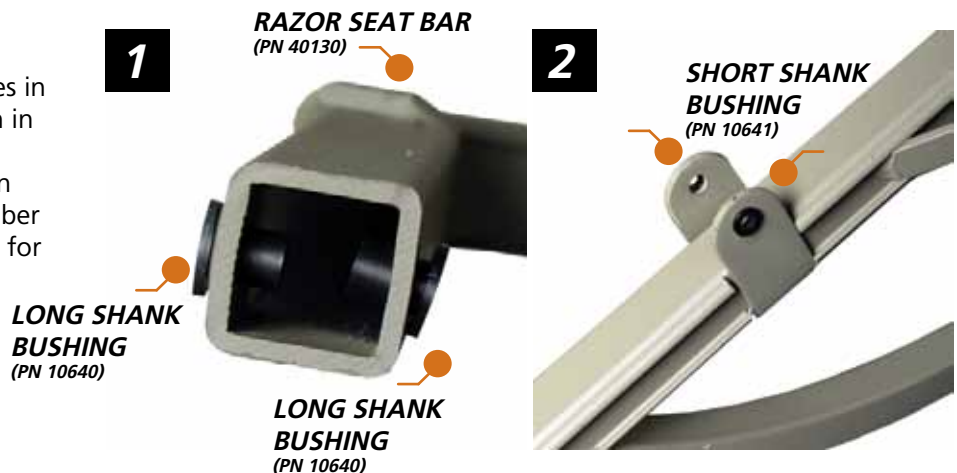

CLIMBING BAR (continued)

3. Position the Razor Seat Bar so that the small welded-on bracket is facing up (**figure 3**). Slide the climbing bar ends into the U-Brackets and secure with one 2" bolt and one lock nut per side - Shown in **figure 4**.

4. Place two short shank bushings in the outside of the remaining bracket on the climbing bar as shown in **figure 5**.

5. Insert the remaining short shank bushings into the hole on the bar support struts - One per strut. Secure the support strut to the bracket using the 3/4" bolt and lock nut. Support strut must attach to the outside of the bracket as shown in **figure 6**.

6. Slide the 1/4" tall METAL bushing onto the 1 3/4" shoulder bolt. Slide the 15/16" tall nylon spacer into the open end of the stand tubing on the climber. Line up the holes. You may have to remove some metal flashing from around the pre-punched holes.

7. Insert the shoulder bolt and METAL bushing into the hole at the end of the tubing and through the nylon spacer. The large, washer side of the Metal bushing should fit flush with the OUTSIDE of the climber tubing as shown in **figure 7**. Secure with the remaining lock nut and repeat for the other side.

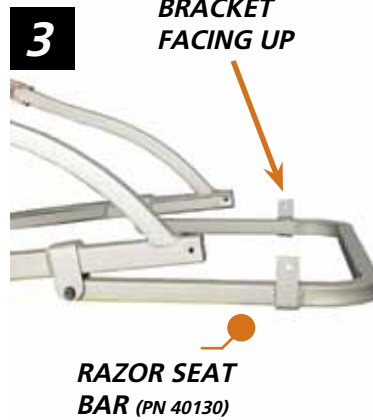

2" BOLT AND LOCK NUT - WRENCH TIGHTEN

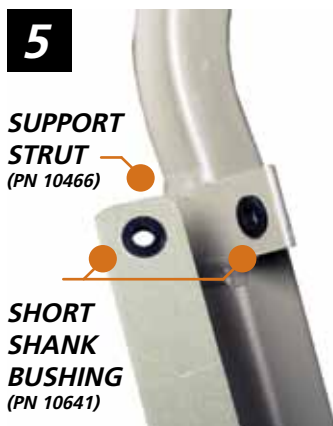

3/4" BOLT AND LOCK NUT - WRENCH TIGHTEN

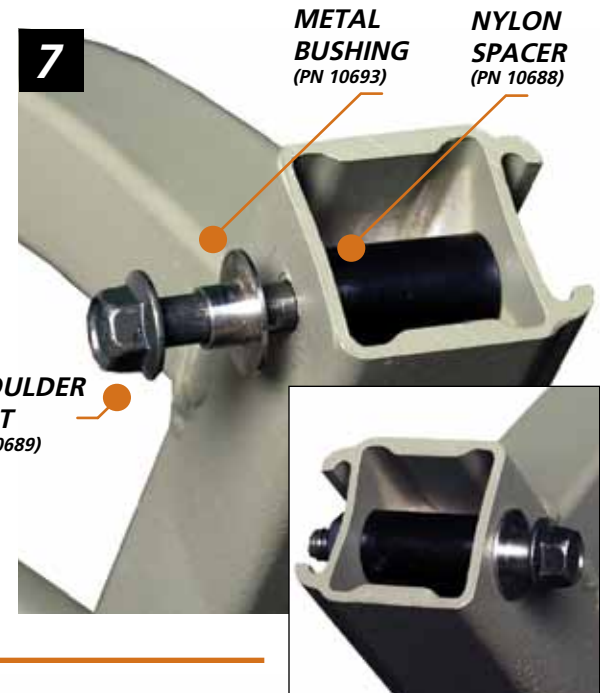

COMFORT PAD

1. Position the two 12" pads as shown in **figure 8**. Secure with 4 In-Line Cable Ties as shown. Please note the Correct and Incorrect ways of using the ties. Use a sharp knife or snips to trim the excess. Rotate the clasp under the pad after they have been trimmed.

2. Position the 18" pad as shown and secure with the remaining two In-Line Cable Ties.

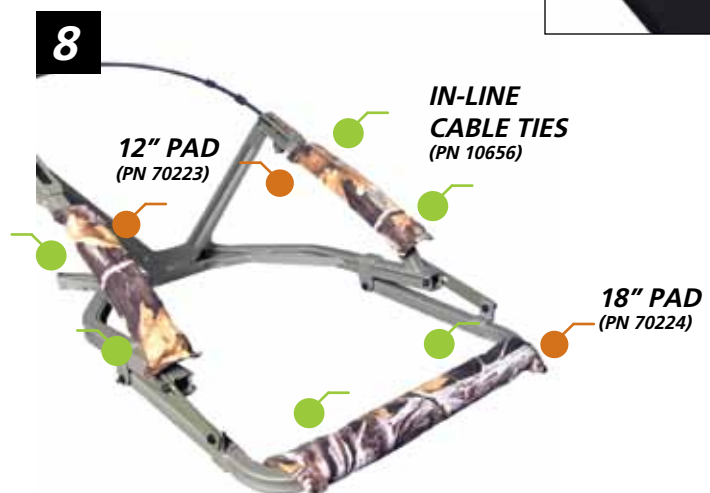
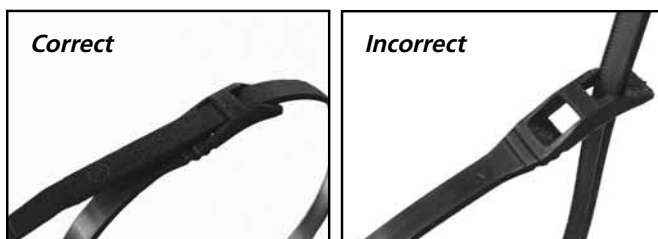

FOAM SEAT

NOTICE

The foam seat included with these treestands is removable for storage. **DO NOT** leave your stand outdoors when it is not being used.

FOAM SEAT (continued)

1. Position the seat inside of the seat climber frame.
2. Wrap the seat strap webbing over the frame from the inside out as shown in **figure 9**.
3. Turn the three bar slide slightly sideways and push it through the metal D buckle that is sewn onto the end of the strap (**figure 10**).



4b OPENSHOT SEAT CLIMBER ASSEMBLY

SEAT ASSEMBLY

1. Route the seat frame bar through the sewn straps on the bottom of the foam seat as shown in **figure 11**. The seat frame bar **MUST** go through both webbing loops as shown.
2. Insert two long shank bushings into the pre-punched holes in one end of the seat frame tube. See **figure 12**. Repeat for other side.
3. Orient the foam seat and seat frame bar with the climber as shown in **figure 13**.
4. Insert one short shank bushing into the **INSIDE** of the welded bracket located on the seat climber as shown in **figure 14**. Repeat for other side.
5. Bring the foam seat and seat frame bar straight back and position it to the outside of both welded brackets. Secure each side using one 1 1/2" bolt and lock nut. See **figure 15**.
6. Your finished seat assembly should look like **figure 16**.

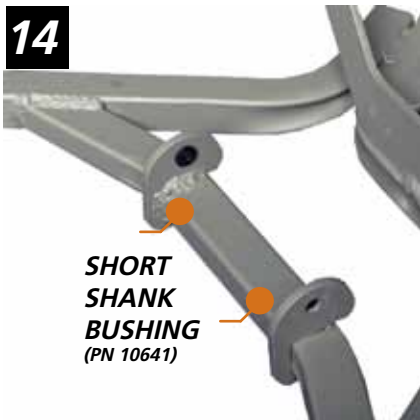

1 1/2" BOLT AND LOCK NUT
- WRENCH TIGHTEN



4c OPENSHOT / RAZOR SHARED ASSEMBLY

RAPIDCLIMB STIRRUPS

1. Position the stirrup as shown in **figure 17**. The curved end of the stirrup should face down and in - toward the center of the platform.
2. Once positioned secure with the supplied bolt and wing nut as shown in **figure 18**. Occasional readjustment might be necessary as your footwear needs change. To adjust, simply loosen the wing nut and slide the stirrup up or down. It is not necessary to completely remove the nut to adjust the stirrup.
3. Wrap the supplied bungee cord around one side of the curved platform upright bars and push the S-hook through the loop as shown in **figure 19**. The bungee should always be attached **ABOVE** the stirrup on the tree side of the upright bars.
4. Pull the hook across the platform and loop it over the opposite upright bar. Hook it back over it self as shown in **figure 20**.

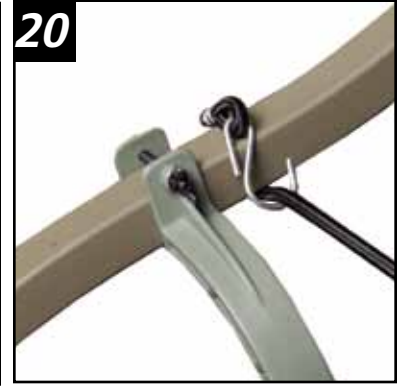
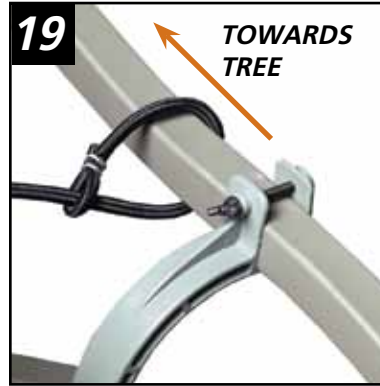

BACKPACK STRAPS

1. Wrap the buckle end of the 2" wide V strap around the second rung on the platform as shown in **figure 21**. Push the 3 Bar Slide through the buckle as shown in **figure 22**. The buckle should look like **figure 23** when complete. Pulling on the straps should cinch down the buckle.
2. Place the looped end of the 1" wide strap around the **platform** tubing at point **A** and bring the loose end back through the loop as shown in **figure 24**. Pull tight to create a cinch knot. Repeat for the other side.
3. Thread the loose end of each 1" strap through the buckle on the 2" V strap as shown in **figure 25**.

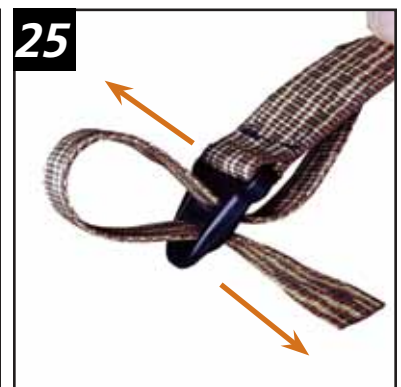
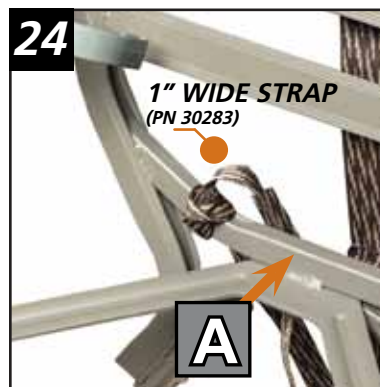

5 SETUP AND USE

⚠ WARNING

Read and understand the harness usage instructions before attempting to climb! Be sure to maintain full body safety harness attachment to the tree at all times after leaving the ground.

ATTACHMENT TO THE TREE

1. Attach the base platform to the tree first. To do this, pull down and hold the QuickDraw cable spring as shown in **figure 26**. This will release the locking tab from the cable, allowing the cable to be pushed past the locking tab. Once the cable has been pushed past the locking tab, you can release the trigger.

ATTACHMENT TO THE TREE (continued)

2. Push the cable into the stand tubing until the cable stop can be lifted up out of the bracket. The cable should be loose at this point. You can now pull the cable out of the stand.

3. Take one end of the cable around the tree and begin to slide it down into the tubing as shown in **figure 27**. Once the cable slides easily into the tubing (it helps to bend the cable upward while pushing down on it as it is inserted), you are ready to place it in its final position.

4. Pull the cable towards the back of the tree and "seat" the cable stop against the back of the bracket, as shown in **figure 28**. The QuickDraw cable spring will "lock" into place behind one of the cable stops. You do not have to hold the QuickDraw trigger to lock the cable in place.

5. Your cable bracket should now look like **figure 29**.

⚠ WARNING

If the QuickDraw cable spring does not lock into place behind the cable stop as shown in **figure 30**, DO NOT USE THE TREESTAND since the cable can release resulting in a user to fall! Contact summit to obtain the proper corrective action.

6. If necessary, go to the other side of the tree and position the other end of the cable by repeating the steps of pulling the QuickDraw cable spring, sliding the cable into the tubing, and assuring that the QuickDraw cable spring has locked into position.

NOTICE

The sole purpose of the plastic coating on the cable is to eliminate noise. After some use you may notice some abrasions, peeling or possibly cuts in the coating. This coating does not affect the performance or safety of your treestand. It is there to eliminate unnecessary noise when sliding the cable down into the tubing.

⚠ WARNING

It is VERY IMPORTANT to inspect the cable on your climbing treestand to ensure that there is no sign of frayed, damaged or broken strands. **DO NOT USE THE CABLE IF IT HAS BROKEN OR DAMAGED METAL STRANDS!** Call immediately to order a replacement if this should occur.

TREE TAPER

To ensure that your treestand is level at the height at which you will be hunting, observe the relative change in the tree diameter between the base of the tree and the final treestand height. It is very important to adjust the treestand base platform and seat at the base of the tree such that the treestand base platform will be level at the height you hunt. Trees commonly found in swamp or marsh areas have a tendency to swell at their base, and these may require a greater starting angle in order for your treestand to be level - as compared to a normally tapered tree.

7. Repeat Steps 1-6 for the Seat Climber portion of the Treestand.

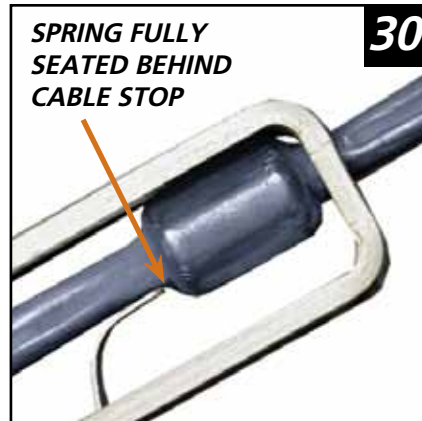
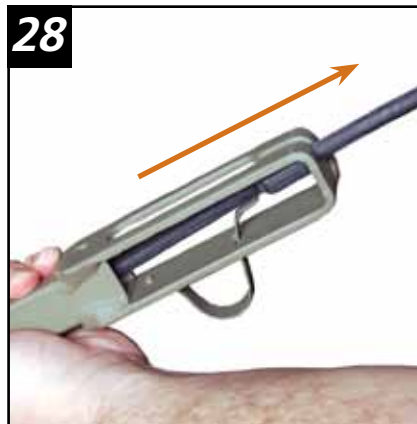
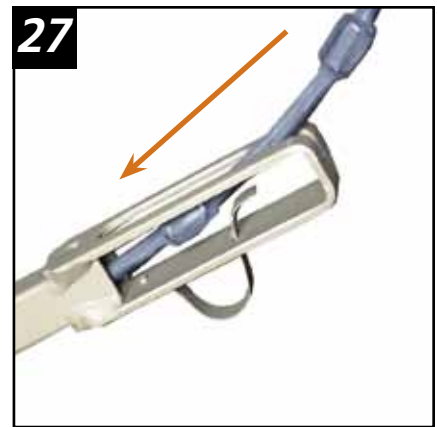
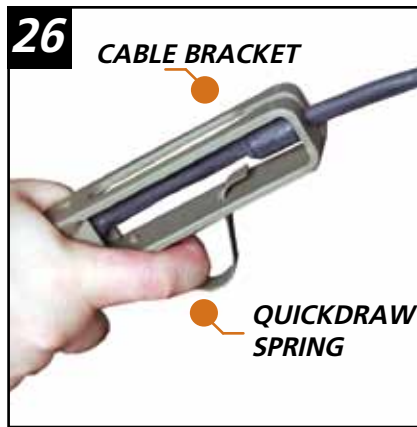

NOTICE

Based on usual taper - in order to ensure the platform and seat climber are level at hunting height, the front edge of the treestand (the edge away from the tree) should be 4-6 inches higher than the edge against the tree (**see figure 31**). The treestand seat climber attaches above the standing platform and should also have the same basic angle as the platform before you start to climb.



UMBILICAL ROPE

⚠ WARNING

The seat climber and platform **MUST BE** attached to each other with the backpack strap / tether strap, as shown in **figure 32 and figure 33** before climbing.

The included umbilical rope attaches the seat climber to the platform. In the event that control of the platform is lost, the platform will only fall the length of the umbilical rope. This should allow you to retrieve the platform and re-seat it onto the tree. Umbilical rope length should be minimized so that the platform can be retrieved with your feet if it is hanging from the rope.

1. Loop the umbilical rope around the seat climber **twice** and tie off with a double knot as shown in **figure 32 (Razor)**.
2. Loop the umbilical rope around the seat climber yolk **twice** and tie off with a double knot as shown in **figure 33 (Openshot)**.
3. Loop the umbilical rope around the platform yolk **twice** and tie off with a double knot for both stands.
4. The platform should now be connected to the seat climber. You should only have to untie one knot to remove the rope for backpacking.

CLIMBING WITH YOUR NEW STAND

⚠ WARNING

At this point **IT IS MANDATORY AND REQUIRED** that you attach your safety harness to the safety strap around the tree and remain connected at all times after leaving the ground.

ALWAYS refer to the written safety harness instructions for proper use of your safety harness.

If you purchased a Razor SS, you must first position the climbing bar in order to sit on it and climb. Position the climbing bar so that the keyhole slot in the support strut will fit over the head of the bolt as shown in **figure 34**. Now slide both support bars - at the same time - over the bolts and completely through the keyhole slots as shown in **figure 35**. Now pull down on the climbing bar (as it is already attached the tree) to "seat" the bolts into the back of the support struts (See **figure 36**). The climbing bar is now ready to use.

1. Following the Harness Instructions, attach the harness tether to the safety strap. Loop the strap around the tree to secure it. See **figure 37**.
2. Your RapidClimb stirrups and bungee heel cord should be already attached to your treestand. To use, back your heel into the bungee heel cord (**figure 38**) then simply slide your boot under the RapidClimb stirrup as shown in **figure 39**.
3. On the Razor, hook the seat back elastic bungee cord around the seat as shown in **figure 40** to keep it secure while you climb.

RAZOR



OPENSHOT



RAZOR



RAZOR



RAZOR



40**RAZOR**

4. To begin climbing, raise your seat climber up to just below waist height and grasp the upright arms very firmly as shown in **figure 41 Razor and figure 42 OpenShot.**

⚠ WARNING

DO NOT TIP YOUR WEIGHT ONTO YOUR TOES unless you are ready to move the platform. This will tend to disengage the platform from the tree.

5. **Razor** - rest all of your weight on the front padded bar. **OpenShot** - rest your weight on your forearms. Pulling up and slightly out on the platform while pointing your toes down should disconnect the platform from the tree.

6. Bring the platform up by raising your legs straight up (**figure 43 Razor and figure 44 OpenShot.**)

7. To re-engage the platform, simply rotate the edge back against the tree upwards, as shown in **figure 45 Razor and figure 46 OpenShot.**

The RapidClimb stirrups are located in such a position that equal distribution of weight will secure the platform to the tree while climbing.

⚠ WARNING

DO NOT JUMP OR BOUNCE ON THE PLATFORM OR SEAT to attempt to cause it to "dig" into the tree. It is not necessary and may cause you to inadvertently disengage the platform or seat.

8. Now ease your weight back onto the platform (to ensure that you have not placed it on an unseen knot or limb on the backside of the tree). Once the platform is secure, stand and slide your safety harness tether up the tree.

9. Once the platform is fully supporting your weight you can disengage the seat climber and raise it back up to just below waist height as shown again in **figure 41 Razor and figure 42 OpenShot.**

Repeat steps 4-9 until you are at your hunting height.

⚠ CAUTION

DO NOT USE the Razor / OpenShot without a Razor / OpenShot seat or other climber. NEVER attempt to climb without a seat climber. The climbers provided with these stands are designed to aid you in the correct operation of the treestand while climbing by keeping your weight away from the tree. The seat climber is also built so that it fits securely with the platform for carrying.

RAZOR**OPENSHOT****41****42****43****44****45****46**

USE

⚠️ WARNING

NEVER DISCONNECT FROM YOUR SAFETY HARNESS OR SAFETY LINE ONCE YOU LEAVE THE GROUND!!

1. When you get to your hunting height (do not climb higher than 15 feet; it is unnecessary) and you have assured that your treestand is level, position your seat climber slightly below waist level. Slightly lower will be more comfortable but higher makes for less movement when you stand.
2. With your safety harness attached to the tree above the climber, pull your feet, one at a time, from their secured position under the RapidClimb stirrups.

⚠️ WARNING

ALWAYS position the safety harness to minimize the amount of slack in the safety line.

3. Wrap the supplied green tourniquet buckle strap (1" green strap with spring loaded buckle) around the tree and through the seat frame as shown in **figure 47**. Securely tighten the strap to prevent the notched teeth area from losing contact with the tree.
4. On the Razor Unhook the bungee cord that held the seat back rest secure while you were climbing. Position the seat back rest by wrapping each end of the bungee cord around the climbing cable and hooking the two hooks together as shown in **figure 48** or by wrapping it around the tree. The bungee cord will prevent the seat backrest from falling forwards if you stand up.
5. The treestand seat will provide maximum comfort when the seat pad is near horizontal rather than tipped down in the front. The seat height on the Razor can be easily raised (for bow hunting) or lowered (for gun hunting) by adjusting the two piece buckles up or down the webbing.

⚠️ CAUTION

Seat strap adjustments must be made on the ground.

Both seat sides must be adjusted evenly so the seat is level side to side. Sliding the webbing straps forward or backward on the frame provides additional comfort.

⚠️ WARNING

DO NOT JUMP OR BOUNCE ON THE PLATFORM OR SEAT to attempt to cause it to "dig" into the tree. It is not necessary and may cause you to inadvertently disengage the platform or seat.



RAZOR



CLIMBING DOWN

⚠️ WARNING

NEVER DISCONNECT FROM YOUR SAFETY HARNESS OR SAFETY LINE ONCE YOU LEAVE THE GROUND!!

1. Reattach your treestand platform to your feet. Refer to Step 2 under Climbing With Your New Stand on Page 8.
2. On the Razor disconnect the elastic cord that has been holding the foam seat in place and fold the seat up. Secure the backrest and seat as shown in **figure 40**. Disconnect and store the strap that has held the seat frame to the tree (**figure 47**).
3. Place the seat climber at about knee level, sit on the padded bar or rest your weight on the arm rests for the OpenShot, and grasp the upright arms as you did when climbing (**see figure 45 Razor and figure 46 OpenShot**).
4. While firmly grasping the seat climber upright arms, disengage the platform by lifting up and tipping the edge closest to the tree downward. Once the platform has been dislodged, you can lower it down (**see figure 43 Razor and figure 44 OpenShot**). Make slow, even movements of 10-12 inches at a time.
5. To re-engage, rotate the top edge of the treestand closest to the tree upwards. Now carefully place your weight back on the platform.
6. Once the platform is secure, slide your safety harness tether strap down to about chest height and repeat steps 3-6 until you have reached the bottom of the tree.
6. Once the platform is secure, stand and slide your safety harness tether strap down to about chest height and **repeat steps 3-6** until you have reached the bottom of the tree.

www.summitstands.com

BACKPACKING THE RAZOR

Your treestand is designed to “nest” together as one unit making it easy to transport.

1. Un-buckle the backpack strap tether from the seat climber yolk and Re-clip it around the perimeter tubing of the platform.
2. Start with the seat climber portion of the stand, set it on its end as shown in **figure 49**.
3. Take the platform and slide it into the seat climber so that its upright braces and cable bracket are next to the same areas on the seat climber as shown in **figure 50**.
4. The teeth area on the platform should come into contact with the “V” brace on the seat climber. From this position, pull the seat backrest through the large gap in the platform as shown in **figure 51**.
5. Secure the seat to the stand by running the seat bungee around the frame and clipping it off. See **figure 52**.
6. Pull the backpack straps out and around the seat webbing and push the seat as far down in the frame as possible (see **figure 53**).
7. Secure the top and platform together with the 1” wide green strap with the spring loaded tourniquet buckle as shown in **figure 54**. This will prevent seat the seat and the platform from making noise as you hike to your hunting location.
8. Use the backpack straps to carry the unit on your back. Pull the loose end of the straps to tighten and pull up on the buckle to release.



BACKPACKING THE OPENSHOT

Your treestand is designed to “nest” together as one unit making it easy to transport.

1. Un-buckle the backpack strap tether from the seat climber yolk and Re-clip it around the perimeter tubing of the platform.
2. Start with the platform portion of the stand, set it on its end as shown in **figure 55**.
3. Take the seat climber and slide it into the platform so that its upright braces and cable bracket are next to the same areas on the seat climber as shown in **figure 56**.
4. Secure the top and platform together with the 1” wide green strap with the spring loaded tourniquet buckle as shown in **figure 57**. This will prevent seat the seat and the platform from making noise as you hike to your hunting location.
8. Use the backpack straps to carry the unit on your back as shown in **figure 58**. Pull the loose end of the straps to tighten and pull up on the buckle to release.



6 TIPS With proper practice you can learn to level your platform without climbing down to re-position the cable. Pulling the cable against the backside of the tree while you are supporting the platform with your legs can do this. While the cable is against the tree, position the platform level and engage the front edge against the tree. This puts a slight bend in the cable while keeping the platform level. Only minor level adjustment, however, can be made using this technique. (The DVD shows this technique).

Sometimes on a cold, dry, hard bark tree a rubbing noise can be produced at the scalloped edge that engages the tree. This comes from friction forces. It can be eliminated a couple of ways. First, simply re-positioning your platform slightly will in most cases eliminate the noise. Second, a liquid or candle/bowstring wax can be applied at the intersection of the tree and the scalloped edge to reduce the friction. Also, using a file to remove the finish and slightly upset (roughen) the smooth metal surface contact points on the scallops can eliminate the noise.

Changing your sitting position can relieve muscle stress and reduce fatigue. This will allow a longer hunt and perhaps an opportunity for a shot. Although it must be done slowly and quietly, repositioning and changing the height of your seat by raising or lowering the seat frame just a couple of inches could make a difference. This changes the hip to knee angle. Moving the seat straps, again slowly and quietly, forward or backward on their support bar will alter the sitting position also. Being comfortable will result in no movement and reduce being detected by game either from sight or from sound.

7 MAINTENANCE AND CARE

The seat on this treestand is removable. We recommend it be removed and stored in a dry place when not in use.

The powdercoat finish applied at the factory is very durable and should only need touch ups in areas of heavy wear or accidental impact.

Should you damage any part of your Summit Treestand, contact your nearest authorized Summit dealer or the factory to obtain the proper corrective action procedure and/or replacement parts for the treestand.

⚠ CAUTION

Look for nicks, gouges, cuts, cracks, bends, corrosion or similar damage that can be the result of improper use or accidental damage. For instance, this could occur if someone else used the treestand without knowledge of its proper use, or if the treestand were dropped, hit by a motor vehicle or subject to corrosive conditions, etc.

Summit Treestands have the highest structural integrity by design, material selection and manufacturing techniques, but as its owner, only your continued care will assure trouble free performance. When the above-mentioned guidelines are followed, your Summit Treestand will provide years of successful hunting.

8 HARNESS SUSPENSION

It is necessary and very important that someone knows your hunting location and time of return. It is also very important that you carry (on your person) emergency communication devices such as a cell phone, two-way radio, whistle, signal flare or preferably a PLD (Personal Locator Device - FCC approved July, '03). When triggered, a PLD will transmit an emergency signal to local rescue teams identifying your location via satellite GPS coordinates. PLD's may be purchased at Wilderness outfitters or on the internet.

Suspension trauma or blood pooling can occur when suspended motionless in a harness for periods of time. This can lead to unconsciousness and death. A suspension relief strap is furnished with your harness. Read your harness instructions to assure that you know how to use it.

⚠ WARNING

If you have to hang in the tree before help arrives, you need to exercise your legs by pushing off from the tree or by using the enclosed suspension relief strap. See the treestand harness instructions and the enclosed instructions for more information.

Self extraction may be necessary in the unfortunate situation that (A) no one knows your location, (B) your communication efforts are exhausted, (C) you are confident that you have the strength, dexterity and ability to perform self-extraction and (D) you decide this is your "absolute last resort". It is recommended to carry a device to assist with this self-extraction. Simple devices such as screw-in steps or a rope "Tree Descender" (available from Summit) will allow you to remove the weight from your harness. This may enable you to return to the treestand/ladder/climbing steps or slowly descend the tree.

Several optional products/systems are available that offer self-recovery or self extraction from a fall when suspended in a harness. Returning to the ground obviously also relieves suspension trauma and some systems automatically descend the user while others allow user control. If one of these products/systems is selected for use as an additional safety precaution against prolonged suspension, be sure to follow the manufacturers' directions for safe use.

9 LIMITED WARRANTY

(A) Warranty

Summit Treestands, LLC (Summit) warrants to the original retail purchaser that all products manufactured by it are free from defects in material and manufacture at the time of shipment for sixty (60) months from the date of purchase. Summit will repair or replace any part found defective if the unit claimed to be defective shall be returned to Summit, postage prepaid, within the warranty period.

This warranty shall not apply to any product which has been subjected to misuse; misapplication; neglect (including but not limited to improper maintenance); accident; improper installation; modification (including but not limited to use of unauthorized parts or attachments); adjustment or repair. THE FOREGOING IS IN LIEU OF ALL OTHER WARRANTIES, WHETHER EXPRESS OR IMPLIED (INCLUDING THOSE OF MERCHANTABILITY AND FITNESS OF ANY PRODUCT FOR A PARTICULAR PURPOSE), AND OF ANY OTHER OBLIGATION OF LIABILITY ON THE PART OF THE COMPANY.

(B) Limitation of Liability

It is expressly understood that Summit's liability for its products, whether due to breach of warranty, negligence, strict liability, or otherwise, is limited to the repair of the product, as stated above, and Summit will not be liable for any other injury, loss, damage, or expense, whether direct or consequential, including but not limited to loss of use, income, profit, or damage to material, arising in connection with the sale, installation, use of, inability to use, or the repair or replacement of Summit's products.

Summit reserves the right to make alterations or modifications in its products at any time, which in its opinion, may improve the performance and efficiency of the product. It shall not be obligated to make such alterations or modifications to products already in service.

Please take the time to fill out the warranty card online at <http://www.summitstands.com/warranty> or fill out and mail in the enclosed warranty card.

© 2010 Summit Treestands, LLC
715 Summit Dr. Decatur, AL 35601
(256) 353-0634
info@summitstands.com