

Viper (All Models) / Summit Goliath SS / Summit 180 SS Summit 180 Max SS / Summit Titan

2008 Instruction Booklet

Please read carefully BEFORE using your new Summit Climbing Treestand.

Congratulations! You have purchased the finest commercially available treestand on the market today. Summit Climbing Treestands are designed and built to provide years of trouble-free, successful hunting with a minimum of maintenance and care. They are certified to meet the requirements of the Treestand Manufacturers Association (TMA) Standards. This booklet is provided to you to outline the recommended use, care and maintenance of your Summit Climbing Treestand.

WARNING

You must fully read, understand and follow these warnings and instructions (written and video)! Failure to follow these instructions may cause serious injury or death!!

You **MUST** also view the enclosed DVD **BEFORE** using your new treestand!!

WEIGHT LIMIT 300 LBS:
VIPER (ALL MODELS), 180

WEIGHT LIMIT 350 LBS:
GOLIATH, 180 MAX, TITAN

**Stand minimum and maximum
tree size: 8-20" diameter**

- **WHEN HUNTING FROM A TREESTAND FALLS CAN OCCUR ANY TIME AFTER LEAVING THE GROUND CAUSING INJURY OR DEATH! FOR THOSE REASONS ALWAYS WEAR A FALL ARREST SYSTEM (FAS) COMPRISING A FULL BODY HARNESS AT ALL TIMES AFTER LEAVING THE GROUND. YOU MUST STAY CONNECTED AT ALL TIMES AFTER LEAVING THE GROUND WHILE USING CLIMBING AND HANG-ON TREESTANDS. SINGLE SAFETY BELTS AND CHEST HARNESSES ARE NO LONGER PREFERRED AND SHOULD NEVER BE USED. IF YOU ARE NOT WEARING A FULL BODY HARNESS THAT IS PROTECTING YOU FROM A FALL, DO NOT LEAVE THE GROUND!**
- **READ AND UNDERSTAND ALL OF THE MANUFACTURER'S WARNINGS AND INSTRUCTIONS AND USE ALL SAFETY DEVICES PROVIDED. CONTACT SUMMIT TREESTANDS FOR ANY QUESTIONS. FAILURE TO DO SO COULD RESULT IN INJURY OR DEATH!**
- **A SIGNAL DEVICE SUCH A MOBILE PHONE, RADIO, WHISTLE, SIGNAL FLARE OR PERSONAL LOCATOR DEVICE (PLD) MUST BE ON YOUR PERSON AND READILY AVAILABLE AT ALL TIMES! INFORM SOMEONE OF YOUR HUNTING LOCATION, WHERE THE TREESTAND WILL BE LOCATED AND THE EXPECTED DURATION OF THE HUNT!**
- **DO NOT USE ANY TREESTAND UNLESS YOU ARE IN GOOD PHYSICAL SHAPE AND HAVE NO PHYSICAL LIMITATIONS OR MEDICAL CONDITIONS WHICH MAY PREVENT YOU FROM SAFELY USING THIS PRODUCT. ALWAYS CONSULT A PHYSICIAN IF YOU HAVE ANY QUESTIONS ABOUT YOUR PHYSICAL ABILITY TO USE THIS PRODUCT.**
- **NEVER USE A TREESTAND WHILE TAKING DRUGS, ALCOHOL OR CERTAIN PRESCRIPTION DRUGS! ALWAYS CONSULT A PHYSICIAN IF YOU HAVE ANY QUESTION ABOUT TAKING SPECIFIC MEDICATIONS AND USING THIS PRODUCT!**
- **NEVER USE A TREESTAND DURING INCLEMENT WEATHER SUCH AS RAIN, LIGHTNING, WINDSTORMS OR ICY CONDITIONS!**
- **NEVER USE A TREESTAND WHEN FEELING ILL, NAUSEOUS, DROWSY OR DIZZY!**
- **BE WELL RESTED AND NEVER HURRY. HURRYING CAUSES ACCIDENTS!**
- **NEVER USE A TREESTAND ON A DEAD, LEANING, DISEASED, LOOSE BARKED TREE, ON A UTILITY POLE OR ON TREES THAT HAVE ANY OBSTRUCTIONS THAT MAY LIMIT TREESTAND USE! NEVER RELY ON A TREE BRANCH FOR SUPPORT!**
- **NEVER JUMP OR BOUNCE ON A TREESTAND TO SECURE IT TO THE TREE!**
- **PULL UP A BOW, BACKPACK, FIREARM OR OTHER EQUIPMENT ONLY AFTER SECURING YOUR SAFETY HARNESS TO THE TREE. FIREARMS MUST BE PULLED UP UNLOADED, CHAMBER OPEN AND MUZZLE DOWN!**
- **UNDER NO CIRCUMSTANCE SHOULD YOU EVER RELEASE THE CABLE FROM THE PLATFORM OR SEAT CLIMBER TO MAKE ADJUSTMENTS ONCE YOU ARE OFF THE GROUND!!!**
- **NEVER MODIFY YOUR STAND IN ANY WAY BY MAKING REPAIRS, REPLACING PARTS, OR ALTERING ADDING OR ATTACHING ANYTHING TO IT EXCEPT IF EXPLICITLY AUTHORIZED BY THE MANUFACTURER!**
- **PRACTICE INSTALLING, ADJUSTING AND USING YOUR TREESTAND AT GROUND LEVEL PRIOR TO USING IT AT ELEVATED POSITIONS!**
- **INSTRUCTIONS (WRITTEN AND VIDEO) SHOULD BE KEPT IN A SAFE PLACE AND REVIEWED AT LEAST ANNUALLY. IT IS THE RESPONSIBILITY OF THE TREESTAND OWNER TO FURNISH THE INSTRUCTIONS TO ANY PERSON THAT WHO BORROWS OR PURCHASES THE TREESTAND! THIS SUMMIT TREESTAND IS DESIGNED TO BE USED AS A COMPLETE SYSTEM - NEVER LOAN OR SELL ONLY A PORTION OF THE CLIMBING TREESTAND SYSTEM.**
- **BEFORE EACH USE OF YOUR SUMMIT TREESTAND, ALWAYS INSPECT THE TREESTAND AND HARNESS FOR ANY DAMAGE, CRACKS, TEARS, CABLE WEAR OR ABRASION THAT MAY HAVE OCCURRED IN TRANSPORTING / STORING YOUR TREESTAND. DO NOT USE IF ANY DAMAGE IS FOUND! CONTACT CUSTOMER SERVICE FOR THE APPROPRIATE REPAIR / REPLACEMENT PROCEDURE!**
- **DO NOT LEAVE YOUR TREESTAND OUTDOORS WHEN IT IS NOT BEING USED! ANY STAND TUBING THAT IS ALLOWED TO FILL WITH RAINWATER AND FREEZE WILL RUPTURE OR BURST - DO NOT USE YOUR TREESTAND IF THIS OCCURS!**

Section 1. Assembling Your New Treestand.

Please contact us at www.summitstands.com or 256-353-0634 to obtain any missing parts or if your DVD does not work.

Comfort Pad. The camouflaged foam pad for the frame can be easily attached for additional comfort and noise reduction. The cable ties for attaching the pads are “in-line” cable ties: Note the *Correct and Incorrect* ways of attaching. To attach - pull the cable ties snug, cut off the excess, and rotate the clasp to the underside of the pad. Place the long pad over the front of the seat bar with equal lengths extending on each side and with the opening down. See *Figure 1*. Use the remaining cable ties to secure the pad.

Backpack Straps. The backpack straps consist of three parts - two 1” wide straps each with sewn in loop and one 2” wide strap with buckles and a snap clip.

Step 1. Secure the snap clip around the seat climber perimeter bar as shown in *Figure 2*.

Step 2. Place the looped end of the 1” wide strap around the seat climber stand tubing at point (A) and bring the loose end back through the loop as shown in *Figure 3*. Repeat for other side.

Step 3. Thread the loose end of each 1” strap through the buckle on the 2” strap as shown in *Figure 4*.

NOTICE

Alternate backpack strap attachment location:

180, 180 Max and Titan users might find backpacking more comfortable by attaching the backpack straps to the platform instead of the seat climber. The upper strap should be attached around the first rung (as Shown in *Figure 5*) and the lower straps are attached at position A on the platform as shown in *Figure 6*.

WARNING

You **MUST** also read the Warning on **Page 4** (Alternate tether strap attachment location) if you plan to use your backpack straps mounted on the platform.

Seat Attachment.

The foam seat is removable on this stand. **DO NOT** leave your stand outdoors when you are not using it.

The seat on the 180 and 180 Max is designed to be reversed. **DO NOT** reverse the seats on any other model of stand.

Step 1. Position the seat inside the seat climber frame.

Step 2. Wrap the strap webbing over the frame from the inside out as shown in *Figure 7*.

Step 3. Turn the three bar slide buckle slightly sideways and push it through the metal D buckle sewn onto the end of the strap (See *Figure 8*).

The 180, 180 Max and Ultimate Viper seat has a single sewn strap that is designed to clip over the front perimeter bar as shown in *Figure 9*. This will only need to be attached while the seat is facing the tree.

2008 Closed Front Climber Instruction Index

General Warnings and Precautions

Section 1 Assembling Your Treestand

Section 2 Using your New Treestand

Section 3 Maintenance and Care

Section 4 Adjustments

Section 5 Harness Suspension

Section 6 Tips

Section 7 Warranty Information

Section 8 Parts Lists

Section 9 Ultimate Viper Accessory Instr.

Page 1

Page 2 - 3

Page 3 - 7

Page 7

Page 8

Page 8

Page 8

Page 9

Page 9

Page 10 - 11



Figure 1

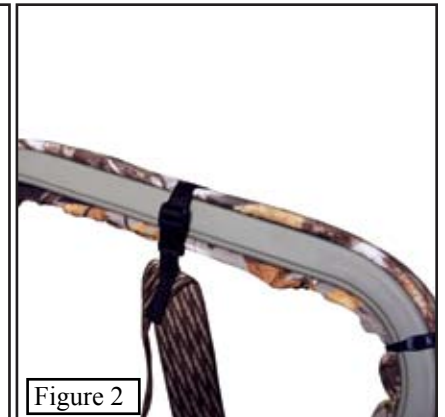

Figure 2

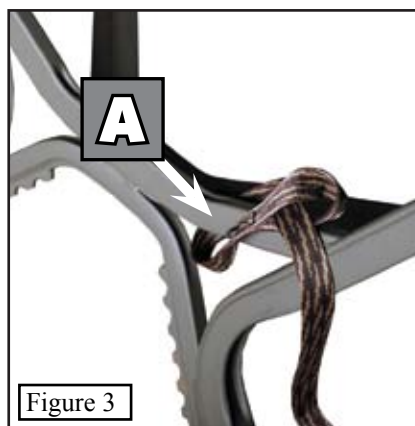

Figure 3

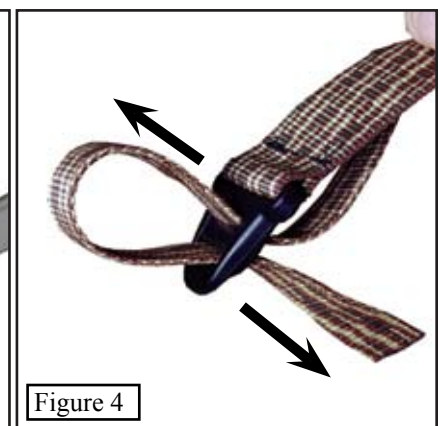

Figure 4



Figure 5

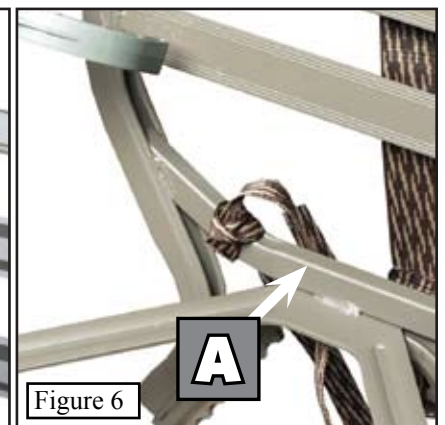

Figure 6

The 180 Max and Ultimate Viper seats also have two sewn loops on either side. Clip these around the arm rest bars to hold the sides of the seat up.

RapidClimb Stirrups. The two (2) RapidClimb stirrups fit on the curved upright arms of the platform. Simply slide one stirrup on each side of the platform so that they are on the inside of the platform and facing down as shown in *Figure 10*. Once positioned, secure with the bolt and wing nut provided as show in *Figure 11*. Occasional readjustment may be required as your footwear needs change. Wrap the supplied bungee cord around one side of the curved platform upright bars and push the S-hook through the loop as shown in *Figure 12*. Hook the S-hook around the opposite curved platform upright bar and back onto itself as shown in *Figure 13*.



Figure 7



Figure 8

Section 2. Using Your New Treestand.

Part 1. Attachment To The Tree.

⚠️ WARNING

Read and understand the harness usage instructions before attempting to climb! Be sure to maintain full body safety harness attachment to the tree at all times after leaving the ground.

Step 1. Attach the base platform to the tree first. To do this, pull down and hold the QuickDraw cable spring as shown in *Figure 14*. This will release the locking tab from the cable, allowing you to remove it from the cable bracket.

Step 2. Push the cable into the stand tubing until the cable stop can be lifted up out of the bracket. The cable should be loose at this point.

Step 3. Take one end of the cable around the tree and begin to slide it down into the tubing as shown in *Figure 15*. Once the cable slides easily into the tubing (it helps to bend the cable upward while pushing down on it as it is inserted), you are ready to place it in its final position.

Step 4. Pull the cable towards the back of the tree and “seat” the cable stop against the back of the bracket, as shown in *Figure 16*. The QuickDraw cable spring will “lock” into place behind one of the cable stops.

Step 5. Your cable bracket should now look like *Figure 17*.

⚠️ WARNING

If the QuickDraw cable spring does not lock into place behind the cable stop, DO NOT USE THE TREESTAND since the cable can release resulting in a user to fall! Contact summit to obtain the proper corrective action.

Step 6. If necessary, go to the other side of the tree and position the other end of the cable by repeating the steps of pulling the QuickDraw cable spring, sliding the cable into the tubing, and assuring that the QuickDraw cable spring has locked into position.

NOTICE

The sole purpose of the plastic coating on the cable is to eliminate noise. After some use you may notice some abrasions, peeling or possibly cuts in the coating. This coating does not affect the performance or safety of your treestand. It is there to eliminate unnecessary noise when sliding the cable down into the tubing.



Figure 9

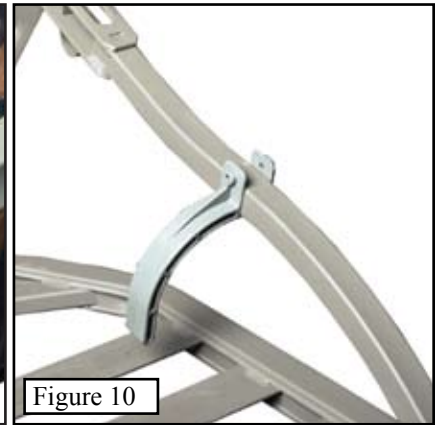

Figure 10

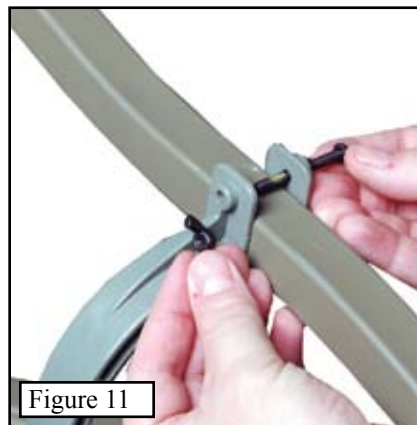

Figure 11



Figure 12

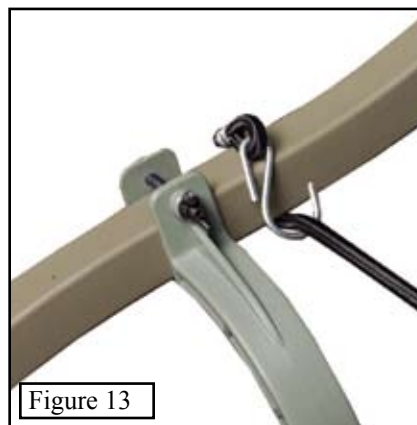

Figure 13



Figure 14

⚠ WARNING

DO NOT USE THE CABLE IF IT HAS BROKEN OR DAMAGED METAL STRANDS! Call immediately to order a replacement if this should occur.

To ensure that your treestand is level at the height at which you will be hunting, observe the relative change in the tree diameter between the base of the tree and the final treestand height. It is very important to adjust the treestand base platform and seat at the base of the tree such that the treestand base platform will be level at the height you hunt. Trees commonly found in swamp or marsh areas have a tendency to swell at their base, and these may require a greater starting angle in order for your treestand to be level - as compared to a normally tapered tree.

NOTICE

Based on usual taper - in order to ensure the platform and seat climber are level at hunting height, the front edge of the treestand (the edge away from the tree) should be 4-6 inches higher than the edge against the tree (See Figure 18). The treestand seat climber attaches above the standing platform and should also have the same basic angle as the platform before you start to climb.

Step 7. Repeat Steps 1-6 for the Seat Climber portion of the Treestand.

Step 8. Un-clip the backpack strap snap clip that is wrapped around the perimeter bar on the seat climber.

Step 9. Re-Snap the clip around the yolk of the platform assembly as shown in *Figure 19*. This is your seat climber / platform tether rope.

⚠ WARNING

The seat climber and platform MUST BE attached to each other with the backpack strap / tether strap, as shown in Figure 19.

⚠ WARNING

Alternate tether strap attachment location: Un-clip the tether from the platform rung and attach it to the seat climber yolk as shown in *Figure 20*. The platform **MUST BE** attached to the seat climber before leaving the ground.

Part 2. Climbing With Your New Stand.

Step 1. Now that your platform and seat section are attached to the tree, you are ready to climb. It is **MANDATORY** that you use a safety harness as you climb.

Be sure to read the safety harness instructions for proper use of your safety harness. Following the Harness Instructions, attach the harness tether to the safety strap. Loop the strap around the tree to secure it. *See Figure 21.*

Step 2. Your RapidClimb stirrups and bungee heel cords should be already attached to your treestand. To climb, back your heel into the bungee heel cord (*Figure 22*) then simply slide your boot under the RapidClimb stirrup. Make sure that your boot is secure under the stirrup as shown in *Figure 23.*

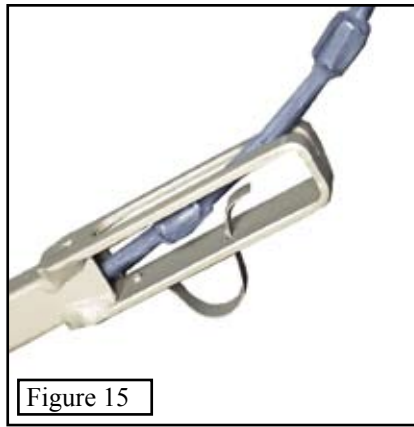

Figure 15

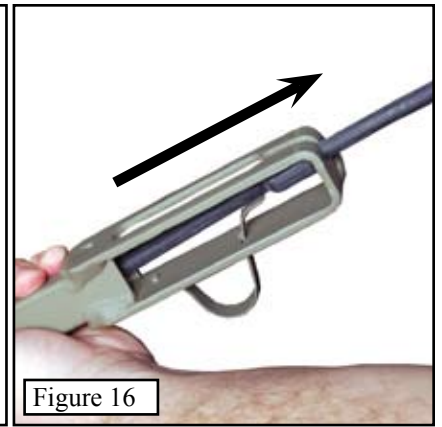

Figure 16

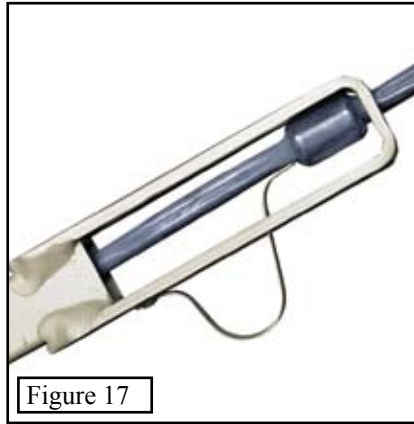
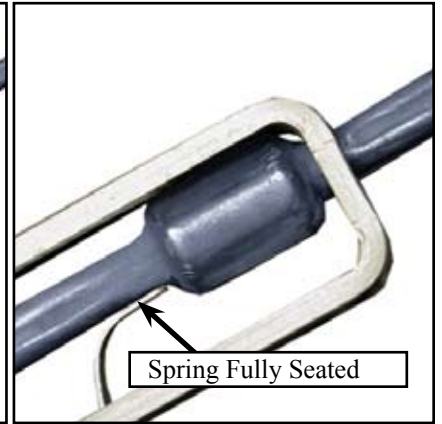

Figure 17



Spring Fully Seated



Figure 18



Figure 19



Figure 20



Figure 21



Figure 22

⚠ WARNING

At this point IT IS REQUIRED THAT YOU attach your safety harness to the safety strap around the tree and remain connected at all times after leaving the ground.

On the Viper and Goliath, hook the seat back elastic bungee cord as shown in *Figure 24* to keep it secure while you climb.

Step 3. To begin climbing, raise your seat climber up to just below waist height and grasp the upright arms very firmly as shown in *Figure 25*.

Step 4. With all of your weight back on the padded bar, or in the seat on the 180 models, disengage the platform by lifting the treestand platform, as shown in *Figure 26*.

Step 5. Bring the platform up by raising your legs straight up.

Step 6. To re-engage the platform, simply rotate the edge back against the tree upwards, as shown in *Figure 27*.



Figure 23



Figure 24

⚠ WARNING

DO NOT JUMP OR BOUNCE ON THE PLATFORM OR SEAT to attempt to cause it to “dig” into the tree. It is not necessary and may cause you to inadvertently disengage the platform or seat.

Step 7. Now ease your weight back onto the platform (to ensure that you have not placed it on an unseen knot or limb on the backside of the tree). Once the platform is secure, slide your safety harness tether up the tree. **Repeat steps 3-7** until you are at your desired hunting height.



Figure 25

⚠ WARNING

DO NOT TIP YOUR WEIGHT ONTO YOUR TOES unless you are ready to move the platform. This will tend to disengage the platform from the tree.

The RapidClimb stirrups are located in such a position that equal distribution of weight will secure the platform to the tree while climbing.



Figure 26

⚠ CAUTION

DO NOT USE the Viper without a Viper seat or other climber. The climbers provided with these stands are designed to aid you in the correct operation of the treestand while climbing by keeping your weight away from the tree. The seat climber is also built so that it fits securely with the platform for carrying.

Part 3. Using Your New Stand.

⚠ WARNING

NEVER DISCONNECT FROM YOUR SAFETY HARNESS OR SAFETY LINE ONCE YOU LEAVE THE GROUND!!

Step 1. When you get to your hunting height (do not climb higher than 15 feet; it is unnecessary) and you have assured that your treestand is level, position your seat climber slightly below waist level. Slightly lower will be more comfortable but higher makes for less movement when you stand.

Step 2. Wrap the supplied green tourniquet buckle strap (1” strap with spring loaded buckle) around the tree and through the seat frame as shown in *Figure 28*. Securely tighten the strap to prevent the notched teeth area from losing contact with the tree.

Step 3. Unhook the bungee cord that held the seat back rest secure while you were climbing. Position the seat back rest by wrapping each end of the bungee cord around the climbing cable and hooking the two hooks together as shown in *Figure 29* or by wrapping it around the tree. The bungee cord will prevent the seat backrest from falling forwards if you stand up.

Step 4. With your safety harness attached to the tree above the climber, simply pull your feet, one at a time, from their secured position under the RapidClimb stirrups.

Step 5. Position your safety harness to minimize the amount of slack in the safety line then carefully sit down. The treestand seat will provide maximum comfort when the seat pad is near horizontal rather than tipped down in the front. The seat height can be easily raised (for bow hunting) or lowered (for gun hunting) by adjusting the two piece buckles

⚠ CAUTION

Seat strap adjustments must be made on the ground.

Both seat sides must be adjusted evenly so the seat is level side to side. Sliding the webbing straps forward or backward on the frame provides additional comfort.

Part 4. Climbing Down With Your New Stand.

⚠ WARNING

NEVER DISCONNECT FROM YOUR SAFETY HARNESS OR SAFETY LINE BEFORE YOU REACH THE GROUND!!

Step 1. Reattach your treestand platform to your feet - **Follow the steps in Part 2, Step 2.**

Step 2. Disconnect the elastic cord that has been holding the foam seat in place and fold the seat up. Secure the backrest and seat as shown previously in *Figure 24*. Disconnect and store the strap that has held the seat frame to the tree (shown in *Figure 28*).

Step 3. Place the seat climber at about knee level, sit on the padded bar (or in the seat on the 180 models), and grasp the upright arms as you did when climbing (see *Figure 30*).

Step 4. While firmly grasping the seat climber upright arms, disengage the platform by lifting up and tipping the edge closest to the tree downward. Once the platform has been dislodged, you can lower it down (see *Figure 31*). Make slow, even movements of 10-12 inches at a time.

Step 5. To re-engage, rotate the top edge of the treestand closest to the tree upwards. Now carefully place your weight back on the platform.

⚠ WARNING

DO NOT JUMP OR BOUNCE ON THE PLATFORM OR SEAT to attempt to cause it to “dig” into the tree. It is not necessary and may cause you to inadvertently disengage the platform or seat.

Step 6. Once the platform is secure, slide your safety harness tether strap down to about chest height and **repeat steps 3-6** until you have reached the bottom of the tree.



Figure 27



Figure 28



Figure 29

Part 5. Backpacking / Carrying Your New Treestand.

Your treestand is designed to “nest” together as one unit making it easy to transport.

Step 1. Un-clip the backpack strap tether from the platform yolk and Re-clip it around the perimeter tubing of the seat climber. If your backpack straps are connected to the platform, you must Re-clip it around the second platform run.

Step 2. Start with the seat climber portion of the stand, set it on its end as shown in *Figure 32*.

Step 3. Take the platform and slide it into the seat climber so that its upright braces and cable bracket are next to the same areas on the seat climber as shown in *Figure 33*.

Step 4. The teeth area on the platform should come into contact with the “V” brace on the seat climber. From this position, pull the seat backrest through the large gap in the platform as shown in *Figure 34*.

Step 5. Secure the seat to the stand by running the seat bungee around the frame and clipping it off. *Figure 35*.

Step 6. If your backpack straps are connected to the platform, the straps will most likely be wedged in behind the seat. Pull them out and around the seat webbing and push the seat as far down in the frame as possible (see *Figure 36*).

Step 7. Secure the top and platform together with the 1” wide green strap with the spring loaded tourniquet buckle as shown in *Figure 37*. This will prevent seat the seat and the platform from making noise as you hike to your hunting location.

Step 8. Use the backpack straps to carry the unit on your back as shown in *Figure 38*. Pull the loose end of the straps to tighten and pull up on the buckle to release.

Section 3. Maintenance and Care of Your Treestand.

Because of the quality construction techniques used in manufacturing, your Summit Treestand is very durable under normal hunting conditions. However, since all hunting equipment that is exposed to the elements requires some maintenance and care, the following guidelines for caring for your treestand should be used.

CAUTION

DO NOT leave your treestand outdoors when it is not being used. Any tubing that is allowed to fill with rainwater and freeze **WILL** rupture or burst. **DO NOT** use your treestand if this happens.

If your treestand is exposed to the elements, it will be necessary to cover the seat to prevent rain and moisture from saturating the material. This will extend the life of the seat material as well as make it more comfortable the next time it is used. The powder coat finish that is applied at the factory is very durable and should need touch ups only in areas of heavy wear or accidental impact. Should you damage any part of your Summit Treestand, contact your nearest authorized Summit dealer or the factory to obtain the proper corrective action procedure and/or replacement parts for the treestand. Unauthorized repairs, modifications, or alterations will void the warranty and could degrade the integrity of the treestand. You must perform periodic inspections of the treestand for damage.



Figure 30



Figure 31

Figure 32



Figure 33



Figure 34



Figure 35

Figure 36



Figure 37

⚠️ WARNING

DO NOT use the treestand if ANY obvious or suspected damage is observed. Contact Summit for proper replacement action.

⚠️ WARNING

It is VERY IMPORTANT to inspect the cable on your climbing treestand to ensure that there is no sign of frayed, damaged or broken strands. If ANY such damage is noticed, you must replace your cable IMMEDIATELY. Replacement covering for the cables is also available as a replacement part.

NOTICE

The plastic covering on the cables serves ONLY as a noise reducer. Over time your cable cover will begin to wear. This is normal.

⚠️ CAUTION

Before EACH use, look for nicks, gouges, cuts, cracks, bends, corrosion or similar damage that can be the result of improper use or accidental damage. For instance, this could occur if someone else used the treestand without knowledge of its proper use, or if the treestand were dropped, hit by a motor vehicle or subject to corrosive conditions, etc.

Summit Treestands have the highest structural integrity by design, material selection and manufacturing techniques, but as its owner, only your continued care will assure trouble free performance. When the above-mentioned guidelines are followed, your Summit Treestand will provide years of successful hunting.

Section 4. Adjustments

The only adjustments that may be required on your Summit Treestand would be the RapidClimb Stirrups, backpack straps or seat height. The RapidClimb Stirrups should be adjusted before you go hunting. Put your hunting boots on and step into the stirrups with the treestand platform on a flat surface. Loosen the wing nut and slide the stirrups until they securely fit your boots, then re-tighten the wing nuts.

To loosen the backpack straps, simply pull up on the thumb tabs. To tighten them, pull down on the loose tag ends of the straps. This can be done before or after the treestand is on your back.

The seat height can be adjusted by means of the two piece buckle on each seat strap. This strap adjustment must be made on the ground and both sides must be adjusted equally so the seat is level side to side.

Section 5. Harness Suspension

It is necessary and very important that someone knows your hunting location and time of return. It is also very important that you carry (on your person) emergency communication devices such as a cell phone, two-way radio, whistle, signal flare or preferably a PLD (Personal Locator Device - FCC approved July, '03). When triggered, a PLD will transmit an emergency signal to local rescue teams identifying your location via satellite GPS coordinates. PLD's may be purchased at Wilderness outfitters or on the internet.



Figure 38

Suspension trauma or blood pooling can occur when suspended motionless in a harness for periods of time. This can lead to unconsciousness and death.

⚠️ WARNING

If you have to hang in the tree before help arrives, you need to exercise your legs by pushing off from the tree or by using the enclosed suspension relief strap. See the treestand harness instructions and the enclosed instructions for more information.

Self extraction may be necessary in the unfortunate situation that (A) no one knows your location, (B) your communication efforts are exhausted, (C) you are confident that you have the strength, dexterity and ability to perform self-extraction and (D) you decide this is your “absolute last resort”. It is recommended to carry a device to assist with this self-extraction. Simple devices such as screw-in steps or a rope “Tree Descender” (available from Summit) will allow you to remove the weight from your harness. This may enable you to return to the treestand/ladder/climbing steps or slowly descend the tree.

Section 6. Tips

With proper practice you can learn to level your platform without climbing down to re-position the cable. Pulling the cable against the backside of the tree while you are supporting the platform with your legs can do this. While the cable is against the tree, position the platform level and engage the front edge against the tree. This puts a slight bend in the cable while keeping the platform level. Only minor level adjustment, however, can be made using this technique. (The DVD shows this technique).

Sometimes on a cold, dry, hard bark tree a rubbing noise can be produced at the scalloped edge that engages the tree. This comes from friction forces. It can be eliminated a couple of ways. First, simply re-positioning your platform slightly will in most cases eliminate the noise. Second, a liquid or candle/bowstring wax can be applied at the intersection of the tree and the scalloped edge to reduce the friction. Also, using a file to remove the finish and slightly upset (roughen) the smooth metal surface contact points on the scallops can eliminate the noise.

Changing your sitting position can relieve muscle stress and reduce fatigue. This will allow a longer hunt and perhaps an opportunity for a shot. Although it must be done slowly and quietly, repositioning and changing the height of your seat by raising or lowering the seat frame just a couple of inches could make a difference. This changes the hip to knee angle. Moving the seat straps, again slowly and quietly, forward or backward on their support bar will alter the sitting position also. Being comfortable will result in no movement and reduce being detected by game either from sight or from sound.

Section 7. Limited Warranty

(A) Warranty

Summit Treestands, LLC (Summit) warrants to the original retail purchaser that all products manufactured by it are free from defects in material and manufacture at the time of shipment for sixty (60) months from the date of purchase. Summit will repair or replace any part found defective if the unit claimed to be defective shall be returned to Summit, postage prepaid, within the warranty period.

This warranty shall not apply to any product which has been subjected to misuse; misapplication; neglect (including but not limited to improper maintenance); accident; improper installation; modification (including but not limited to use of unauthorized parts or attachments); adjustment or repair. THE FOREGOING IS IN LIEU OF ALL OTHER WARRANTIES, WHETHER EXPRESS OR IMPLIED (INCLUDING THOSE OF MERCHANTABILITY AND FITNESS OF ANY PRODUCT FOR A PARTICULAR PURPOSE), AND OF ANY OTHER OBLIGATION OF LIABILITY ON THE PART OF THE COMPANY.

(B) Limitation of Liability

It is expressly understood that Summit's liability for its products, whether due to breach of warranty, negligence, strict liability, or otherwise, is limited to the repair of the product, as stated above, and Summit will not be liable for any other injury, loss, damage, or expense, whether direct or consequential, including but not limited to loss of use, income, profit, or damage to material, arising in connection with the sale, installation, use of, inability to use, or the repair or replacement of Summit's products.

Summit reserves the right to make alterations or modifications in its products at any time, which in its opinion, may improve the performance and efficiency of the product. It shall not be obligated to make such alterations or modifications to products already in service.

Please fill out the warranty card and return to:

SUMMIT Treestands, LLC. -- 715 Summit Dr. -- Decatur, AL 35601

Section 8. Parts List

BOX CONTENTS

PN	DESCRIPTION	QTY
Includes one of the following:		
81062	Platform (All Except Titan)	1
41116	Platform (Titan)	1
Includes one of the following:		
81053	Viper Top (Including Ultimate)	1
81054	Goliath Top	1
81059	180 Top	1
81074	180 Max Top	1
41115	Titan Top	1
Includes one of the following:		
74275	Viper / Goliath Seat	1
74207	180 Seat	1
74201	180 Max / Ultimate Viper Seat	1
Includes:		
30700	Climbing Cable	2
72000	Accessory Packet	1

72000 - ACCESSORY PACKET CONTENTS

PN	DESCRIPTION	QTY
85052	Stirrups (2), Bungee with hook, Hardware	1
74226	72" Camo Front Pad	1
85051	In-Line Cable Ties	8
83054	Summit 4 Point Safety Harness with Attached SRS Strap	1
	Treestand Safety Strap	1
10894	Written Harness Instructions	1
30283	1" Camo Backpack Strap	2
40273	2" Camo Backpack Strap with Clip	1
30285	Tourniquet Strap with Buckle (green)	1
10887	2008 DVD	1

Tools Required

- 7/16" Socket and Ratchet
- 7/16" Wrench
- Side Cutters or Knife for Trimming Cable Ties

Good Hunting and Hunt Safe!

HUNT TOMORROW...

...USE YOUR SAFETY HARNESS TODAY!

©(STLLC 2008)

QUICKDRAW™
CABLE RETENTION

summi]okt™
CONSTRUCTION

RAPIDCLIMB™
STIRRUPS

Summit products are manufactured under one or more of the following US Patents: 5,937,969; 5,971,104; 5,975,242; 5,979,603; 6,125,966; 6,182,792; 6,397,973; D,417,011; D,420,147





Summit Bucksteps and RapidClimb Stirrups are Patent Pending

ULTIMATE VIPER ACCESSORIES AND PARTS LIST

Also included with the Ultimate Viper:

PN	DESCRIPTION	QTY
40104	Gun Rest Tube	1
10950	Comfort Mat	1
11911	Drop Blind	1
21072	Accessory Hardware Kit	1
74224	18" Camo Arm Pad	1
85051	In-Line Cable Ties	6

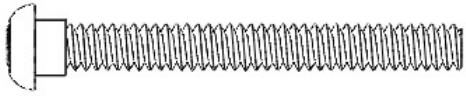
21072 - HARDWARE KIT - ULTIMATE VIPER

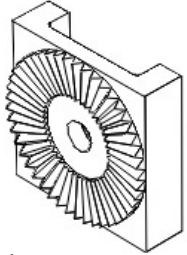
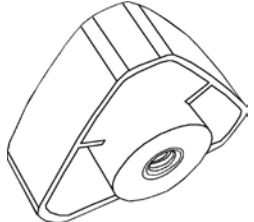
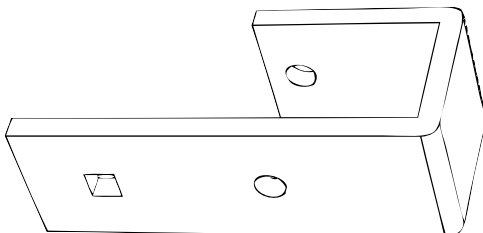
PN	DESCRIPTION	QTY
10612	1/4" Lock Nut (1/4 -20)	2
		
10633	Neoprene Washer	2
		
10632	2 1/2" Carriage Bolt (1/4 -20)	2
		
10601	1 3/4" Bolt (1/4 -20)	2
		
10544	Gun Rest Adjustment Bracket	4
		
10660	Knob	2
		
20431	Gun Rest Mounting Bracket	2
		

Section 9. Ultimate Viper Accessory Assembly

⚠ WARNING

Never sit on this gun rest or attempt to use it as a climbing aid!

Part 1. Gun Rest

Step 1. Position the gun rest mounting bracket as shown in *Figure 1*. The bracket MUST be placed at least 3" up the arm to provide clearance for the platform when the stand is packed together. The long side of the bracket should go on the outside of the stand.

Step 2. Slide one 2 1/2" carriage bolt through the mounting bracket from the inside out.

Step 3. Align one Gun Rest Adjustment Bracket as shown in *Figure 2*. Slide the bracket over the carriage bolt and seat it on the mounting bracket.

Step 4. Position the Neoprene washer as shown in *Figure 2*. Slide the washer over the carriage bolt.

Step 5. Position another Gun Rest Adjustment Bracket as shown below. The teeth should face inward. Slide the bracket over the carriage bolt and seat it against the bracket/washer from **Step 3**.

Step 6. Slide the Gun Rest tube onto the outside bracket. Push the carriage bolt through the pre-punched hole. Use the large knob to secure. The completed bracket assembly should look like *Figure 3*.

Step 7. Repeat process for the other side. The carriage bolt may have to be backed out slightly as you position the two Gun Rest Brackets and the washer between the Gun Rest tube and the Seat Base.

Step 8. Attach the 18" arm pad to the front of the bar using the supplied cable ties.

Step 9. Your completed gun rest should look like *Figure 4*.

Part 2. Drop Blind

Step 1. Your drop blind may ship unfolded. Lay the blind out on a flat surface. Start at the ends of the blind material and roll it up. Once it is completely rolled, tuck it into the pocket and secure with the long Velcro® strip that runs the entire length of the blind.

Step 2. Fold the blind in half and find the center point. There should be a Velcro® loop strap close to the center.

Step 3. Loop this Velcro® loop strap over the stand frame in the middle of the front pad as shown in *Figure 5*.

Step 4. Work from the center back looping the straps over and securing them as shown in *Figure 6*. Repeat for both sides.

Step 5. To use: Start at the back and unhook the long, continuous Velcro® strap and let the blind drop around the stand.

Part 3. Comfort Mat

Step 1. The Comfort Mat has cutouts designed to fit the standard shape of the platform. Lay the mat between the platform arms as shown in *Figure 7*.

Step 2. Make a small, 3/8", incision through the mat just behind the front bar. Insert one cable tie through the mat and around the frame. Trim off the excess as shown in *Figure 8*.

Step 3. Make three more cuts in the locations shown in *Figure 9*. Use the remaining ties to secure the mat to the stand.

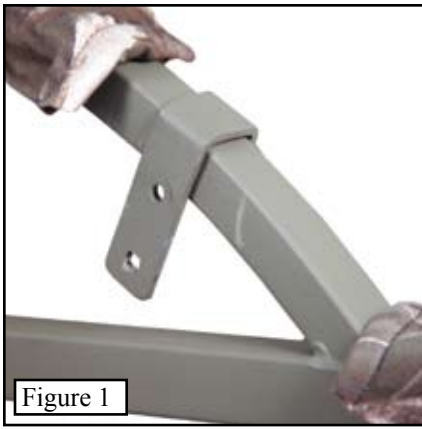

Figure 1

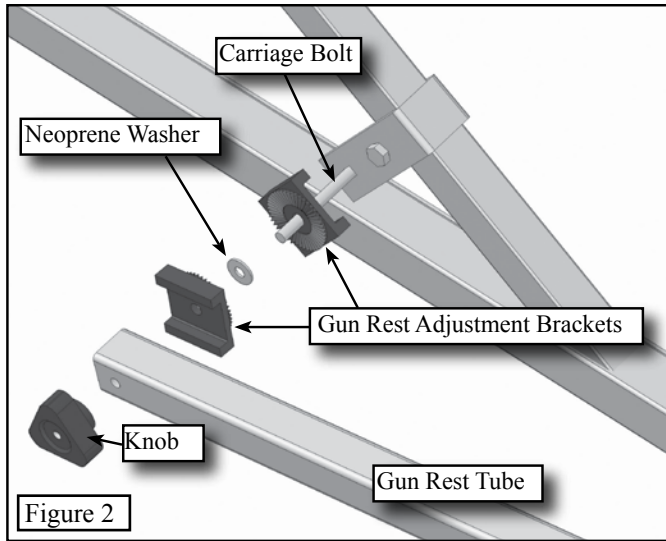

Figure 2

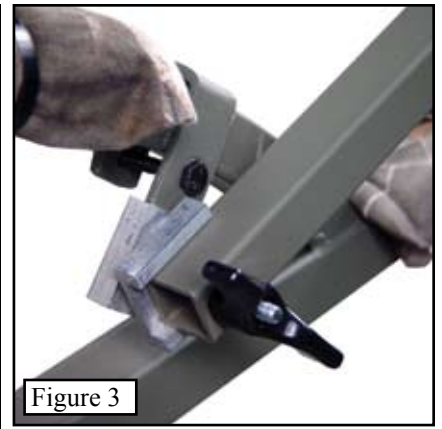

Figure 3



Figure 4



Figure 5



Figure 6



Figure 7



Figure 8



Figure 9

NEW 2008 PRODUCTS



Hot Dot Plus
Electronic Pendulum / Fixed LED Pin Bow Sight
 - Fully open sight window
 - Can be converted to FOX version
 (Kit sold separately)



SUMMIT
 EST. 1981
TREESTANDS

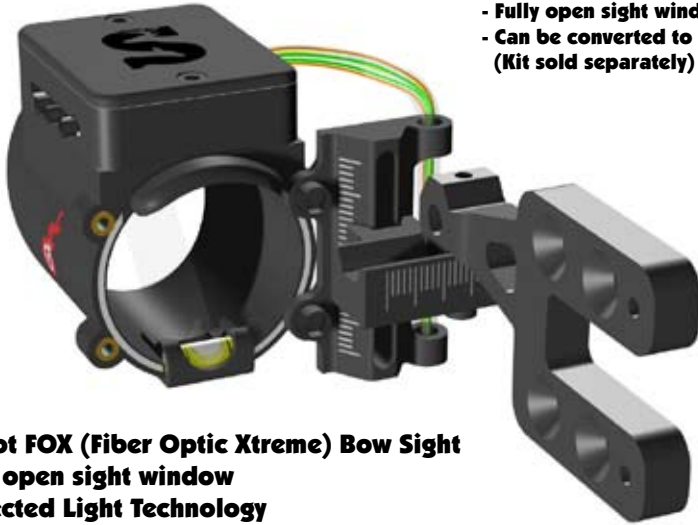

Hot Dot FOX (Fiber Optic Xtreme) Bow Sight
 - Fully open sight window
 - Reflected Light Technology
 - Up to 6 adjustable pins
 - Can be converted to Electronic Version
 (Kit sold separately)
 - Screw in light available



Run - N - Gun Ground Blind
 - Heavy duty design
 - Multiple window configurations
 - Easy to setup / take down / transport



www.summitstands.com

.....
 Cut Along Line

Warranty Card for Summit Climbing Treestand

Model: Viper (81066) Ult. Viper (81072) 180 (81069) 180 Max (81073) Goliath (81067) Titan (81087)

Owners Name: _____ Street Address: _____

City: _____ State: _____ ZIP: _____ Phone: (____) _____

Date Purchased: _____ Price \$: _____ Purchased From (Dealer Name): _____

Your heard about us through: Magazine Advertisement Video Friend Summit Catalog

Other Please Explain: _____

You can also register your warranty card on line at: www.summitstands.com/warranty.aspx