

Product Code

Style Case

Special Ring Binder

same Size as sample

Cap. 1

Die No. 2192

Order No. 35732-7

Plate

O/A 12³/₈ x 10³/₄

Special Instruments Lab Inc.

Metal
Total Vinyl 030
Quantity 300
Date 9-26-78
Type Corners Round
Radius 3/32
Completed

	Gauge	Thick
Tear Seal	16	3/32
Bar Seal	#253	1/8
Bar Seal		

	No. of Feet
Tear Seal	4/2
Bar Seal	2/2
Bar Seal	

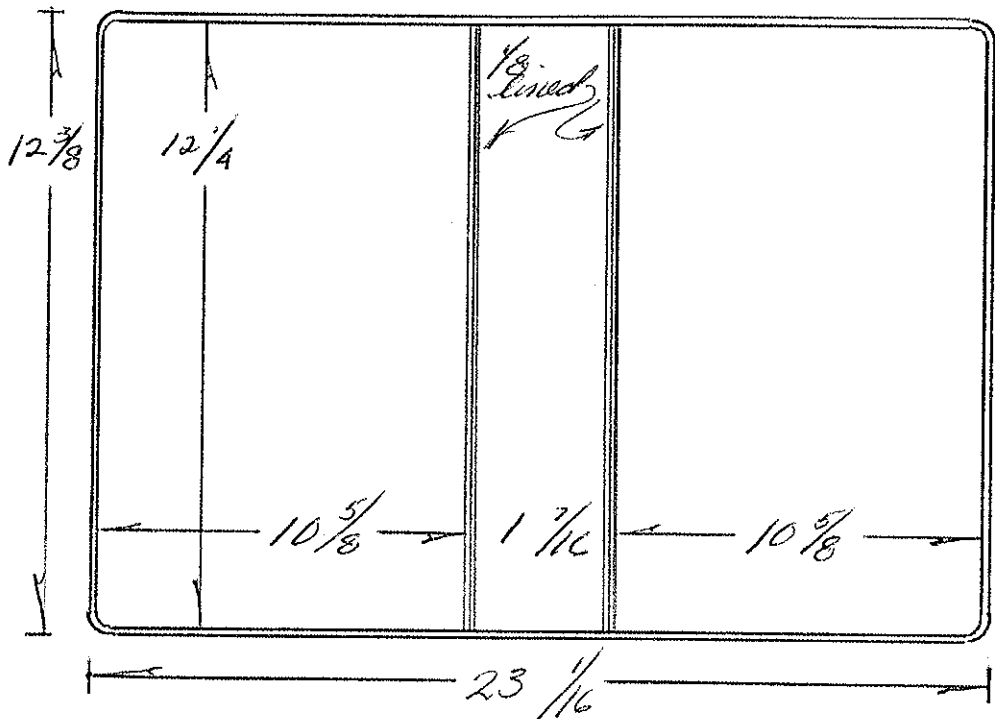

Code	Ga.	Pcs	Cutting Specs		Code	Ga.	Pcs	Cutting Specs	
			Size	Out				Size	Out
Cover Mat.	13	X	23 ¹¹ / ₁₆	1	Lining Mat.	13	X	23 ¹¹ / ₁₆	1
Cover Mat		X			Lining Mat.		X		
Vert. Pckt.		X			Horz. Pckt.		X		
Vert. Pckt.		X			Horz. Pckt		X		
Pocket		X			Pocket		X		
Label Holder		X			Card Holder		X		
Material		X			Material		X		
Material		X			Material		X		
Material		X			Material		X		
F.C. Board	12 ¹ / ₈	X	10 ³ / ₂	1	B.C. Board	12 ¹ / ₈	X	10 ¹ / ₂	1
B.C. Board		X			B.B. Board	12 ¹ / ₈	X	1 ⁵ / ₁₆	1
Center Board		X			Board		X		
Board		X			Strip		X		
Cover Pad		X			Strip		X		
					B.B. Pad		X		

Product Code

Style Case Ring Binder

Sheet Size 14 X 8 1/2 Cap. 2

as sample

Die No. 2706

Order No. 16162-0

Plate

Customer

Coca Cola

Metal
Total Vinyl .024
Quantity 500
Date 10-2-81
Type Corners Rd.
Radius 1/4
Completed

	Gauge	Thick
Tear Seal	.012	3/32
Bar Seal	103	1/8
Bar Seal		

	No. of Feet
Tear Seal	
Bar Seal	
Bar Seal	

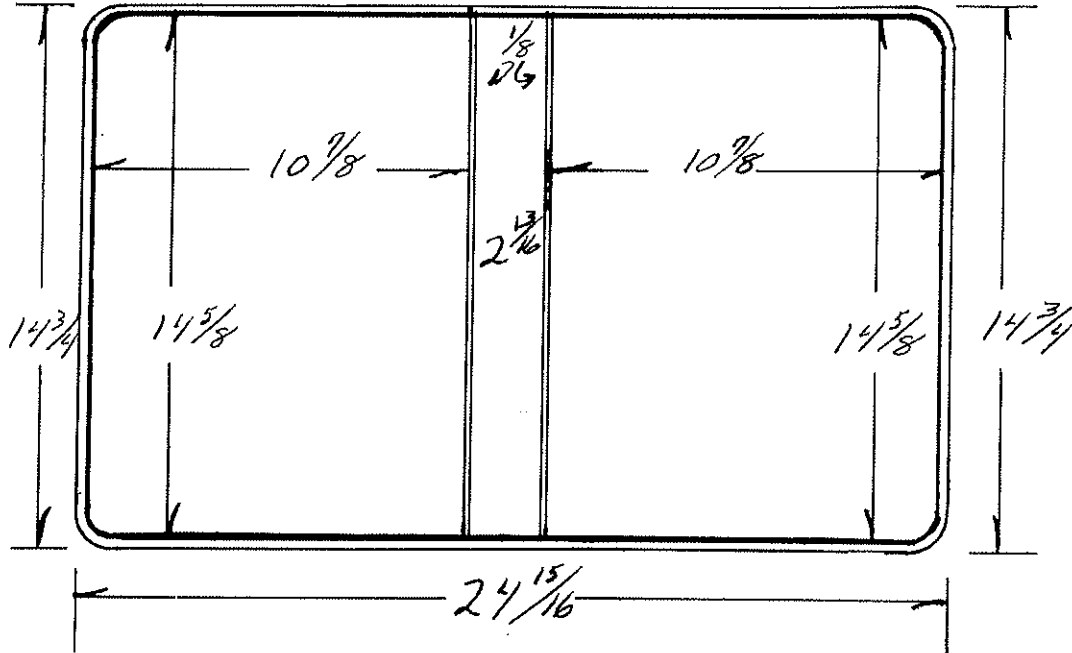

Code		Ga.	#	PCS	Size	Out	Cutting Specs	Code		Ga.	#	PCS	Size	Out	Cutting Specs
Cover Mat.					15 3/8 X 25 9/16		1	Lining Mat.					15 3/8 X 25 9/16		1
Cover Mat.					X			Lining Mat.					X		
Vert. Pckt.					X			Horz. Pckt.					X		
Vert. Pckt.					X			Horz. Pckt.					X		
Pocket					X			Pocket					X		
Label Holder					X			Card Holder					X		
Material					X			Material					X		
Material					X			Material					X		
Material					X			Material					X		
F.C. Board					14 17/32 X 10 23/32	120	1	B.C. Board					14 9/16 X 10 13/16	100	1
B.C. Board					14 7/32 X 2 23/32	120	1	B.B. Board					14 9/16 X 10 13/16	100	1
Center Board					14 17/32 X 10 23/32	120	1	Board					14 9/16 X 2 23/32	100	1
Board					X			Strip					X		
Cover Pad					X			Strip					X		
								B.B. Pad					X		

Product Code P.M.

Style Case Ring Binder

Sheet Size 13 X 11 1/2 Cap. 1 1/2 Die No. 3358 Order No. 948891 Plate

Customer

Sog Printing

Metal
Total Vinyl .030
Quantity 50
Date 7-16-85
Type Corners R _d
Radius 1/4
Completed

	Gauge	Thick
Tear Seal	016	3/32
Bar Seal	178	3/16
Bar Seal		

	No. of Feet
Tear Seal	
Bar Seal	
Bar Seal	

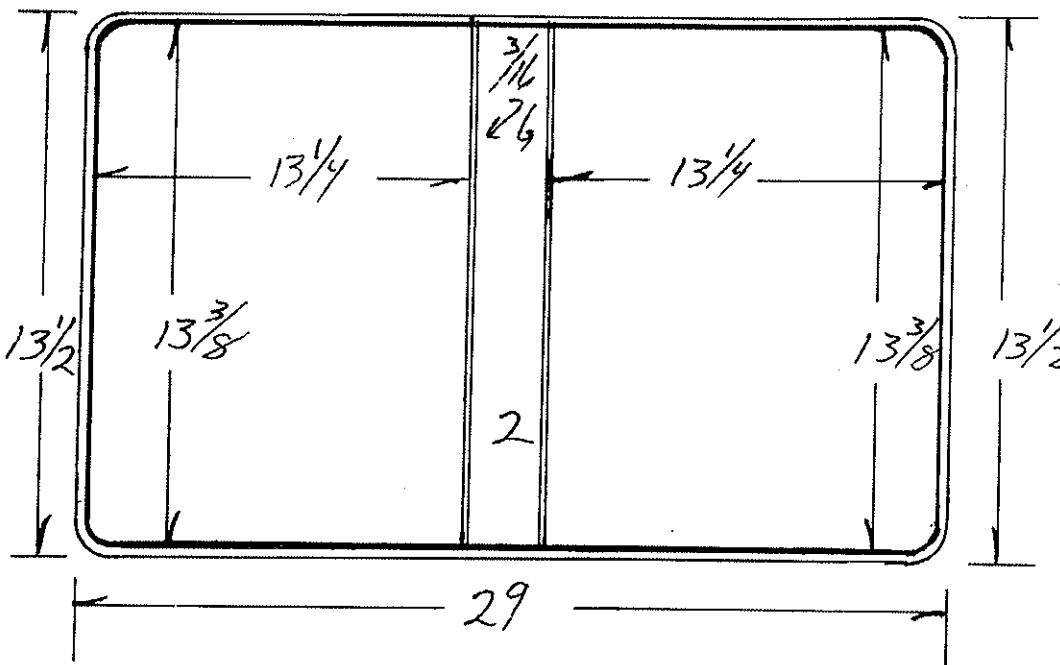

Code	Ga.	#	PCS	Cutting Specs		Code	Ga.	#	PCS	Cutting Specs	
				Size	Out					Size	Out
Cover Mat.			1	14 1/8 X	29 5/8	Lining Mat.			1	14 1/8 X	29 5/8
Cover Mat.				X		Lining Mat.				X	
Vert. Pckt.				X		Horz. Pckt.			1	6 5/16 X	13 13/16
Vert. Pckt.				X		Hbrz. Pckt.			1	13 9/16 X	29 5/8
Pocket				X		Pocket				X	
Label Holder				X		Card Hlder				X	
Material				X		Material				X	
Material				X		Material				X	
Material				X		Material				X	
F.C. Board			1	13 1/4 X	13 1/8	B.C. Board			1	13 1/4 X	13 1/8
B.C. Board				X		B.B. Board			1	13 1/4 X	1 7/8
Center Board				X		Board				X	
Board				X		Strip				X	
Cover Pad				X		Strip				X	
						B.B. Pad				X	

Product Code

Style Case

V 19 B

Sheet Size

12 x 7 1/2

Cap.

1/2

Die No. 3972

Order No.

95 8027

Plate

Customer

Blair Towne & Bingham

Metal
Total Vinyl
Quantity
Date
Type Corners
Radius
Completed

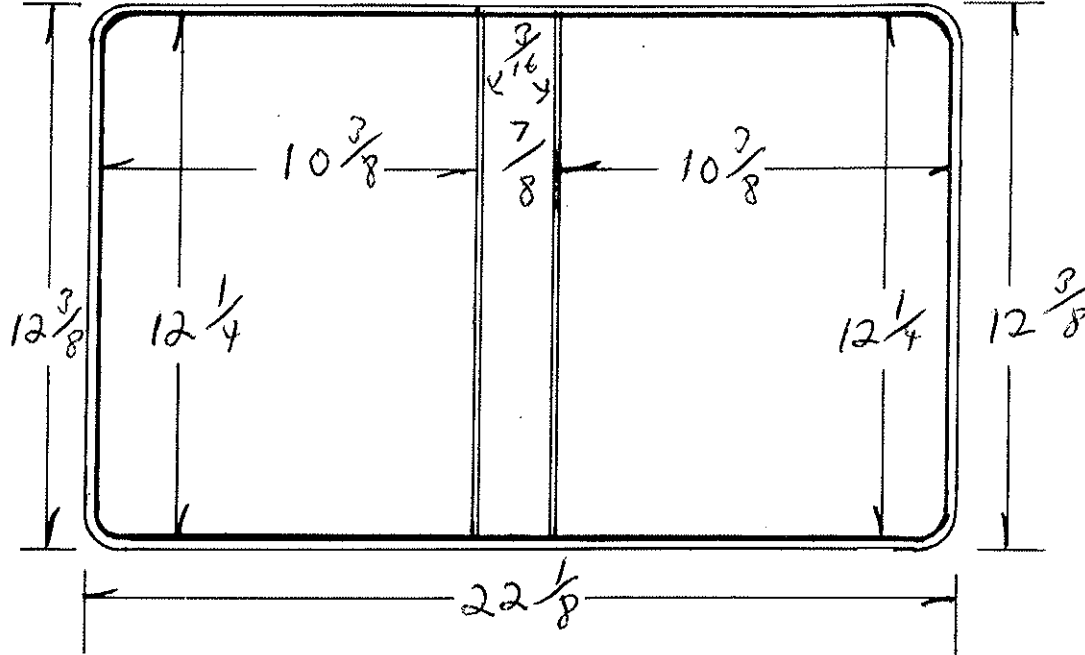

	Gauge	Thick
Tear Seal	16	9/32
Bar Seal	178	2/16
Bar Seal		

	No. of Feet
Tear Seal	
Bar Seal	
Bar Seal	

Code	Ga.	#	Cutting Specs		Code	Ga.	#	Cutting Specs	
			Size	Out				Size	Out
Cover Mat.			13 3/8 x 23 1/8	1	Lining Mat.			13 3/8 x 23 1/8	1
Cover Mat.			X		Lining Mat.			X	
Vert. Pckt.			X		Horz. Pckt.			5 7/8 x 10 15/16	1
Vert. Pckt.			X		Horz. Pckt.			X	
Pocket			X		Pocket			X	
Label Hoker			X		Card Hlder			X	
Material			X		Material			X	
Material			X		Material			X	
Material			X		Material			X	
F.C. Board			12 5/8 x 10 9/16	1	B.C. Board			12 5/8 x 10 9/16	1
B.C. Board			X		B.B. Board			12 5/8 x 2 5/8	
Center Board			X		Board			X	
Board			X		Strip			X	
Cover Pad			X		Strip			X	
					B.B. Pad			X	

OLD # 1155

VRB

Product Code

Style Case

Sheet Size 12 5/16 x 9 1/2

Cap. Z

Die No. 4306

Order No. 963789

Plate

Customer

SALT RIVER PROJECT

Metal
Total Vinyl
Quantity 100
Date
Type Corners
Radius
Completed 10-25-89 RET

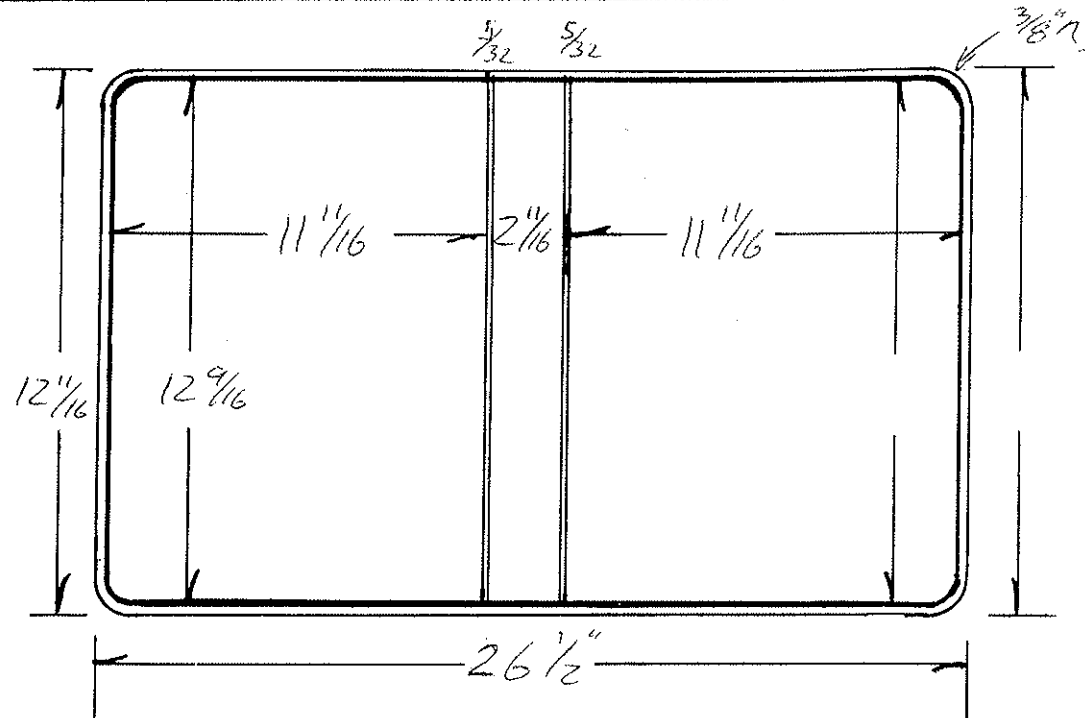

	Gauge	Thick
Tear Seal		
Bar Seal		
Bar Seal		

	No. of Feet
Tear Seal	
Bar Seal	
Bar Seal	

SIZE BY B.P.

CHECK BY: gm

Code	Ga.	Pcs	Cutting Specs		Code	Ga.	Pcs	Cutting Specs	
			Size	Out				Size	Out
Cover Mat.		15	1		Lining Mat.	15	1		
Cover Mat.					Lining Mat.				
Vert. Pckt.					Horz. Pckt. Full		1		
Vert. Pckt.					Horz. Pckt. 1510C		1		
Pocket					Pocket				
Label Holder					Card Hlder				
Material					Material C.O.L.		1		
Material					Material FL-B.B.		1		
Material					Material F.C.		1		
F.C. Board			1		B.C. Board				
B.C. Board			1		B.B. Board		1		
Center Board					Board				
Board					Strip				
Cover Pad					Strip				
					B.B. Pad				

Product Code

Style Case URB A.D.N.B.

Sheet Size 12 1/4 x 10 1/2 Cap. 1" A.O. Die No. 4752

Order No. 968820 Plate C-14-

Customer

VARION EXTRION

Metal
Total Vinyl
Quantity <u>4</u>
Date <u>5-8-91</u>
Type Corners
Radius <u>1/8</u>
Completed

	Gauge	Thick
Tear Seal	<u>.014</u>	<u>1/8</u>
Bar Seal	<u>48-4</u>	<u>5/32</u>
Bar Seal		

	No. of Feet
Tear Seal	
Bar Seal	
Bar Seal	

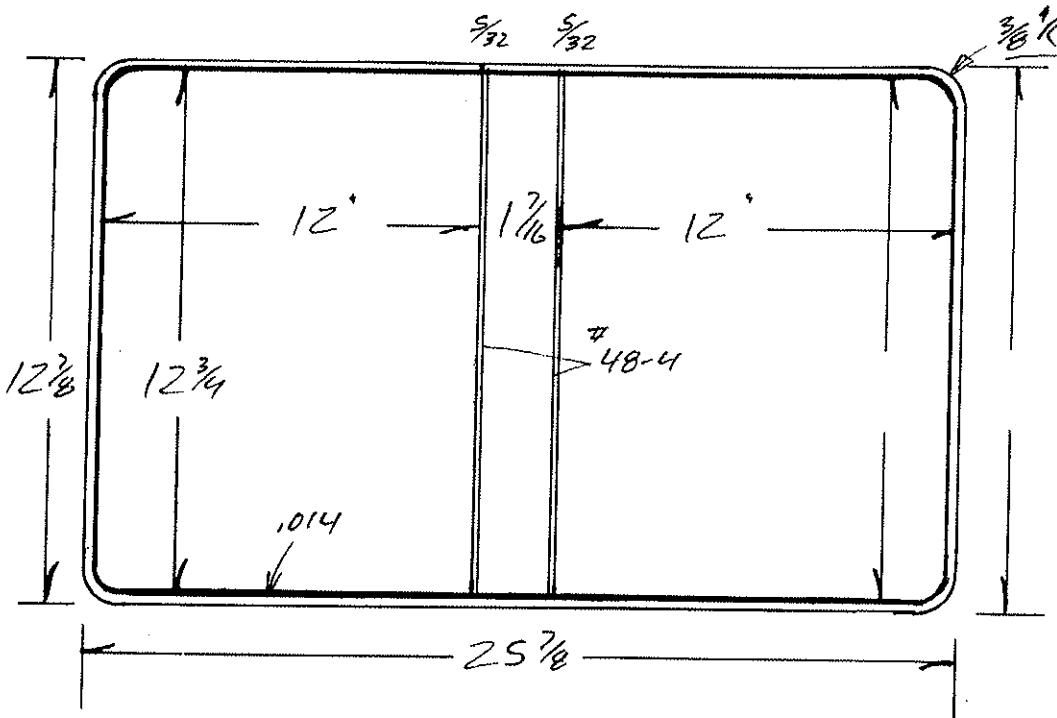

Dwg - B. Pool
Check
KPV

Cutting Specs

Code		Ga.	PCS	Size	Out	Code		Ga.	PCS	Size	Out
Cover Mat.	<u>13 5/8 x 26 5/8</u>	<u>15</u>	<u>1</u>			Lining Mat.	<u>13 5/8 x 26 5/8</u>	<u>15</u>	<u>1</u>		
Cover Mat	X					Lining Mat.	X				
Vert. Pckt.	X					Horz. Pckt.	X				
Vert. Pckt.	X					Horz. Pckt.	X				
Pocket	X					Pocket	X				
Label Holder	X					Card Hlder	X				
Material	<u>COL. 3 13" x 26 5/8</u>					Material	X				
Material	X					Material	X				
Material	X					Material	X				
F.C. Board	<u>12 21/32 x 11 29/32</u>	<u>120</u>	<u>1</u>			B.C. Board	X				
B.C. Board	<u>12 21/32 x 11 29/32</u>	<u>120</u>	<u>1</u>			B.B. Board	<u>11 21/32 x 1 11/32</u>	<u>100</u>	<u>1</u>		
Center Board	X					Board & U.	<u>11 21/32 x 1 11/32</u>	<u>25</u>	<u>1</u>		
Board	X					Strip	X				
Cover Pad	X					Strip	X				
						B.B. Pad	X				

Product Code

Style Case VRB L.L. A.O.

Sheet Size 12 X 12 1/2 Cap. 2" A.O. Die No. 4767

Order No. 968823

Plate C-14

Customer

Metal	
Total Vinyl	
Quantity	50
Date	5-16-91
Type Corners	
Radius	3/8
Completed	

	Gauge	Thick
Tear Seal	.014	1/16
Bar Seal	.4084	5/32
Bar Seal		

	No. of Feet
Tear Seal	
Bar Seal	
Bar Seal	

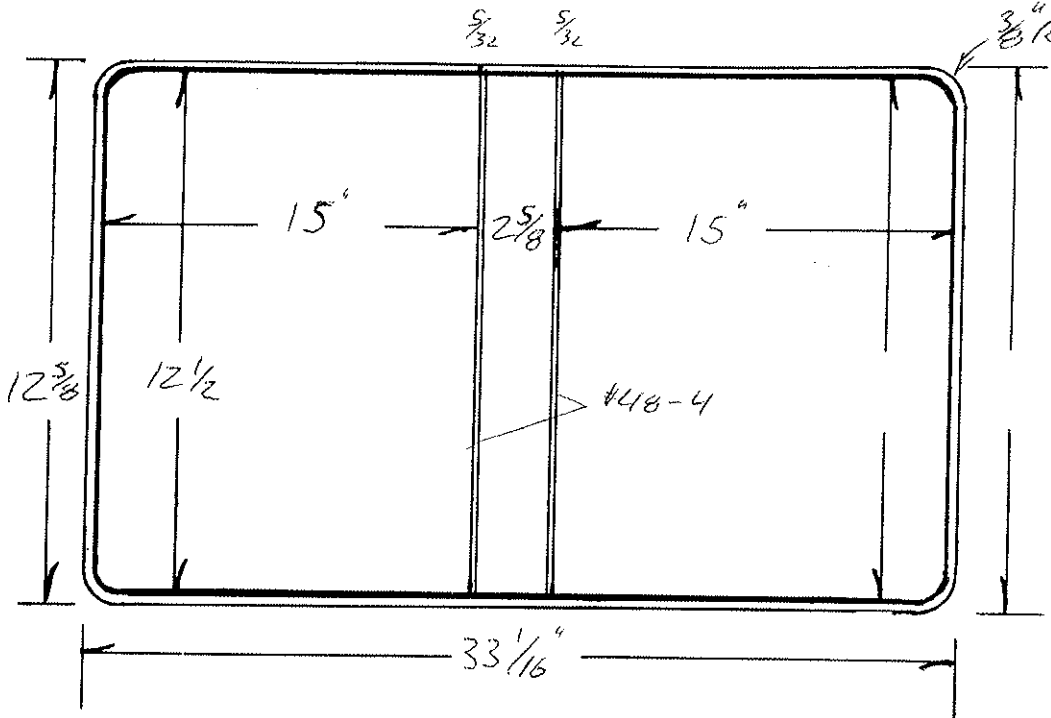

Orig. B. Price
Check - *(Signature)*

Code	Ga.	#	Cutting Specs		Code	Ga.	#	Cutting Specs	
			Size	Out				Size	Out
Cover Mat.			13 3/8 X 34"	1	Lining Mat.			13 3/8 X 34"	1
Cover Mat			X		Lining Mat.			X	
Vert. Pckt.			X		Horz. Pckt.			X	
Vert. Pckt.			X		Horz. Pckt.			X	
Pocket			X		Pocket			X	
Label Holder			3" X 2 7/8"	8	Card Holder			X	
Material			X		Material			X	
Material			X		Material			X	
Material			X		Material			X	
F.C. Board			12 13/32 X 14 29/32	120	B.C. Board			X	
B.C. Board			12 13/32 X 14 29/32	120	B.B. Board			12 13/32 X 2 17/32	120
Center Board			X		Board			X	
Board			X		Strip			X	
Cover Pad			X		Strip			X	
					B.B. Pad			X	

Product Code

Style Case *CASSETTE ALBUM 4-V*

Size *12 x 9 1/2* Cap. *1 15/16* Die No. *5156* Order No. *634431* Plate *D10-8*

Customer

HOST COMMUNICATIONS

Metal
Total Vinyl
Quantity <i>20,000</i>
Date <i>8-6-92</i>
Type Corners
Radius <i>3/8</i>
Completed

	Gauge	Thick
Tear Seal	<i>016</i>	<i>1/16</i>
Bar Seal	<i>178</i>	<i>3/16</i>
Bar Seal		

	No. of Feet
Tear Seal	
Bar Seal	
Bar Seal	

Dwg. B.Pace

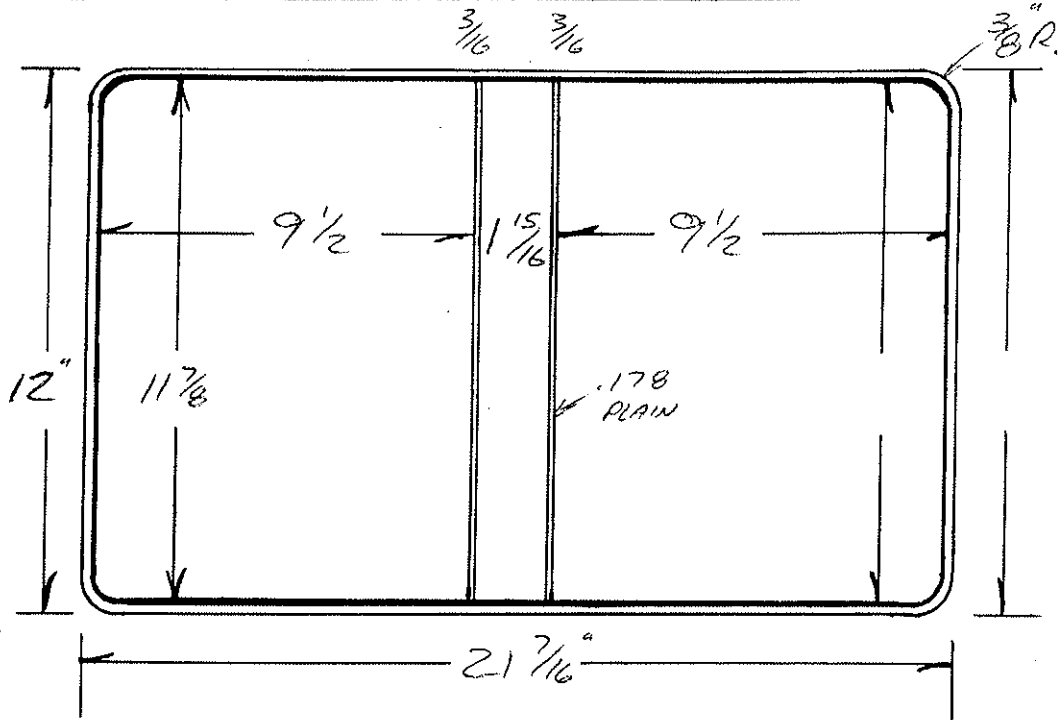

Code	Ga.	# PCS	Cutting Specs		Code	Ga.	# Pcs.	Cutting Specs										
			Size	Out				Size	Out									
Cover Mat.			<i>12 3/4</i>	<i>X 22 1/4</i>	1			Lining Mat.	<i>12 3/4 X 3 1/8</i>									
Cover Mat				<i>X</i>				Lining Mat.	<i>12 3/4 X 22 1/4</i>									<i>(if using Remil Vin)</i>
Vert. Pckt.				<i>X</i>				Horz. Pckt.										
Vert. Pckt.				<i>X</i>				Horz. Pckt.										
Pocket				<i>X</i>				Pocket										
Label Holder				<i>X</i>				Card Holder										
Material			<i>PLTORNA</i>	<i>12 3/4 X 22 1/4</i>				Material										
Material				<i>X</i>				Material										
Material				<i>X</i>				Material										
F.C. Board				<i>11 13/16 X 9 7/16</i>	<i>100</i>	<i>1</i>		B.C. Board										
B.C. Board				<i>11 13/16 X 9 7/16</i>	<i>100</i>	<i>1</i>		B.B. Board					<i>11 13/16 X 1 27/32</i>	<i>100</i>	<i>1</i>			
Center Board				<i>X</i>				Board					<i>X</i>					
Board				<i>X</i>				Strip					<i>X</i>					
Cover Pad				<i>X</i>				Strip					<i>X</i>					
								B.B. Pad					<i>X</i>					

Product Code

Style Case

Sheet Size 12 X 18 1/2 Cap. 1"

Die No. 5182

Order No. 973629

Plate D12

Customer

Baytown Chemicals

10-28

Metal
Total Vinyl
Quantity 40
Date 10-13-92
Type Corners RND
Radius 3/8
Completed

3/8
3/8
" "

3/8

	Gauge	Thick
Tear Seal	.014	4in
Bar Seal	484	5/32
Bar Seal		

	No. of Feet
Tear Seal	
Bar Seal	
Bar Seal	

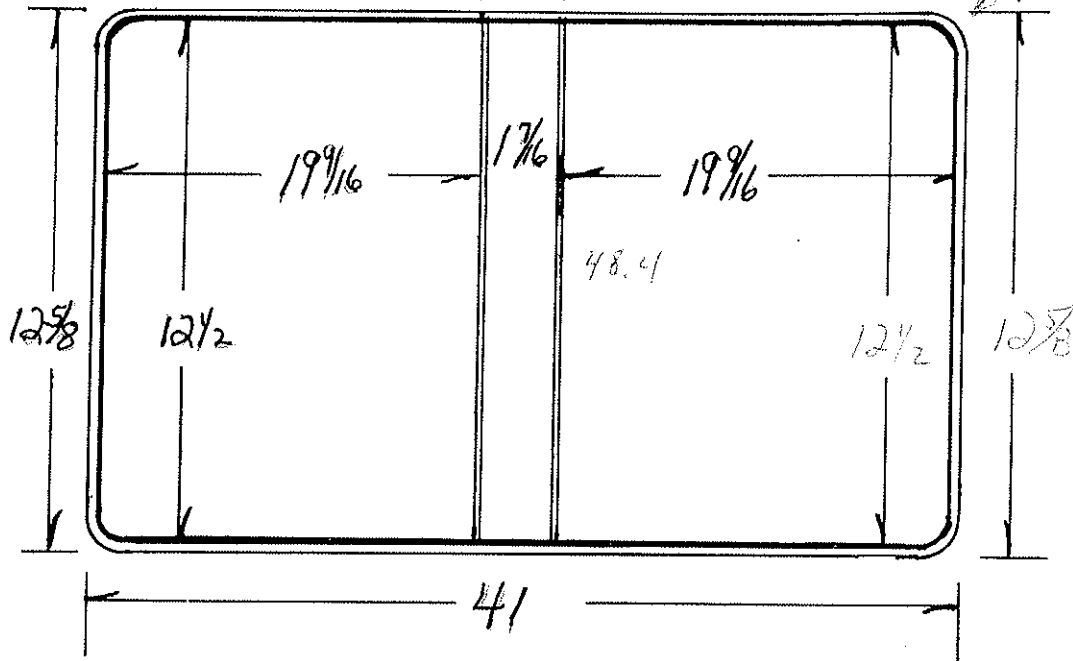

Code	Ga.	#	Cutting Specs		Code	Ga.	#	Cutting Specs	
			Size	Out				Size	Out
Cover Mat.			13 3/8 X	4 1/4	Lining Mat.			13 3/8 X	4 1/4
Cover Mat.			X		Lining Mat.			X	
Vert. Pckt.			X		Horz. Pckt.			X	
Vert. Pckt.			X		Horz. Pckt.			X	
Pocket			X		Pocket			12 1/2 X	4 1/4
Label Holder			X		Card Holder			X	
Material			X		Material			X	
Material			X		Material			X	
Material			X		Material			X	
F.C. Board			12 7/16 X	19 1/2	B.C. Board			12 13/32 X	19 15/32
B.C. Board			12 7/16 X	19 1/2	B.B. Board			12 13/32 X	1 1/32
Center Board			12 7/16 X	1 1/32	Board			12 13/32 X	19 15/32
Board			X		Strip			X	
Cover Pad			X		Strip			X	
					B.B. Pad			X	

DIE #	5328	STYLE CASE	Angle D	LOCATION	E1-1
SHEET SIZE	12 ³ / ₈ X 10 ⁹ / ₁₆ +	CAP.	1 ¹ / ₂	ORDER NO.	975150
CUSTOMER	Financial Fidelity Svcs			DUE DATE	

QUANTITY	100
DATE	5-18-93

RADIUS	3/8
COMPLETED	

TEAR SEAL	.014
BAR SEAL	484

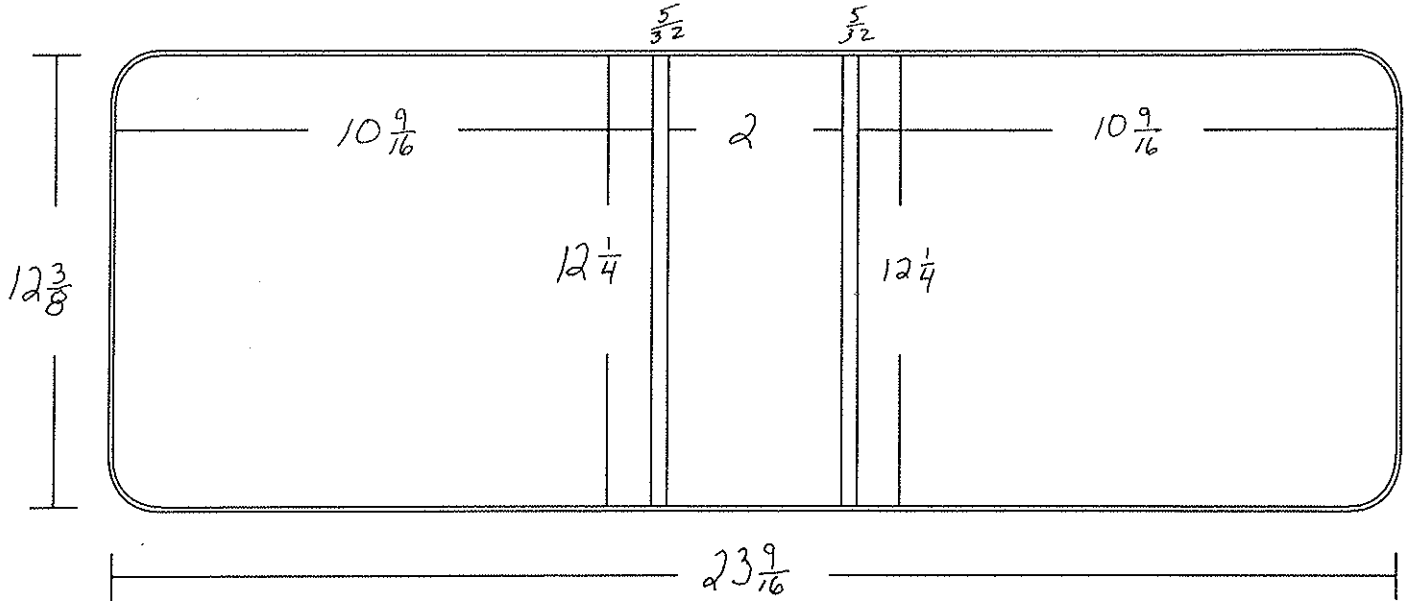

MATERIAL

	CODE	GA	PCS		CODE	GA	PCS
COVER MATL	13 ¹ / ₈ X 24 ⁵ / ₁₆		1	LINING	13 ¹ / ₈ X 24 ⁵ / ₁₆		1
COVER MATL	X			LINING	X		
VERT PKT	X			HORZ PKT	5 ³ / ₈ X 24 ⁵ / ₁₆		1
VERT PKT	X			HORZ PKT	X		
CARD HOLDER	X			DIAGONAL PKT	X		
COL	X			LABEL HOLDER	X		
EX. COL	X			GUSSETT	X		
	X			REINF.	X		
	X				X		

PRINTS

FRONT COVER	X	BACK BONE	X	BACK COVER	X
-------------	---	-----------	---	------------	---

BOARDS

	CODE	PT	PCS		CODE	PT	PCS
F.C. BOARD	12 ³ / ₁₆ X 10 ¹ / ₂	100	1	F.C. BOARD	12 ⁵ / ₃₂ X 10 ¹⁵ / ₃₂	120	1
B.B. BOARD	12 ³ / ₁₆ X 1 ²⁹ / ₃₂	100	1	B.B. BOARD	12 ⁵ / ₃₂ X 1 ²⁹ / ₃₂	120	1
B.C. BOARD	12 ³ / ₁₆ X 10 ¹ / ₂	100	1	B.C. BOARD	12 ⁵ / ₃₂ X 10 ¹⁵ / ₃₂	120	1
B. UP STRIP	X				X		
	X				X		

DIE # 5329	STYLE CASE	LOCATION E1-2
Overall SHEET SIZE $12\frac{3}{8}$ X $9\frac{7}{8}$ +	CAP. 1"	ORDER NO.
CUSTOMER Financial Fidelity Svcs	DUE DATE	

QUANTITY	100
DATE	5-19-93

RADIUS	$\frac{3}{8}$
COMPLETED	

TEAR SEAL	.014
BAR SEAL	484

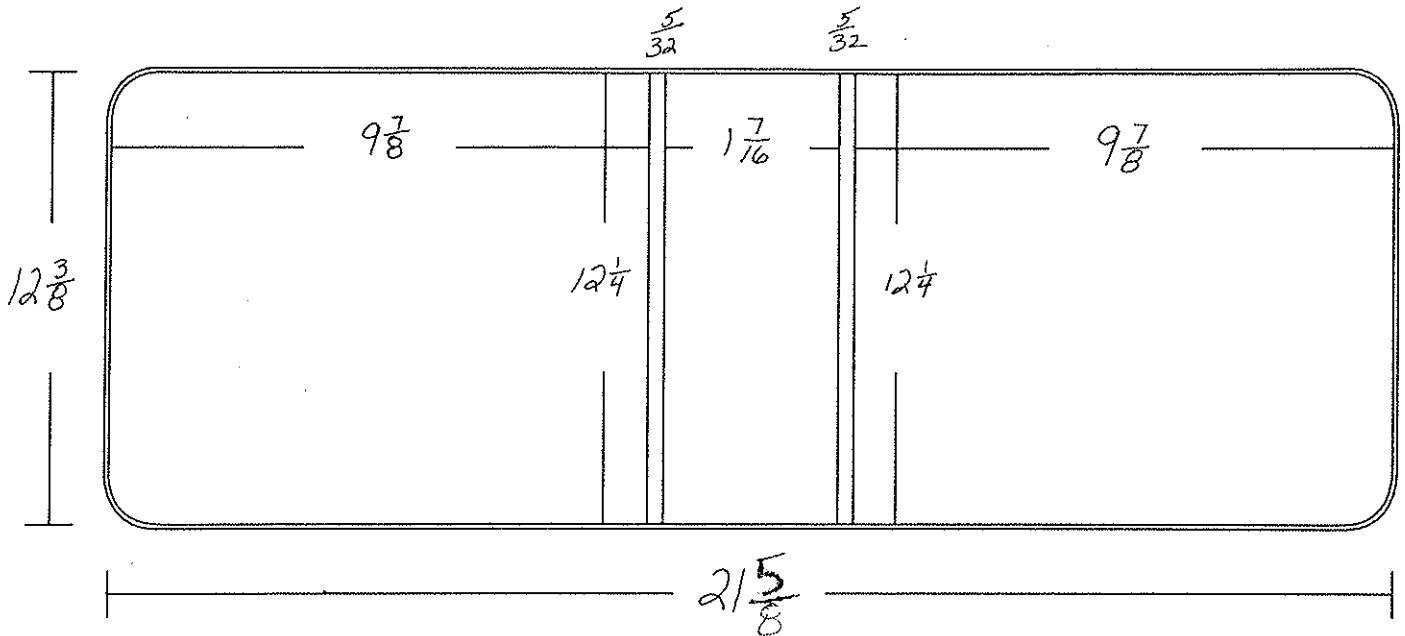

MATERIAL

	CODE	GA	PCS		CODE	GA	PCS
COVER MATL	$13\frac{1}{8}$ X $22\frac{1}{4}$		1	LINING	$13\frac{1}{8}$ X $22\frac{1}{4}$		1
COVER MATL	X			LINING	X		
VERT PKT	X			HORZ PKT	$5\frac{3}{8}$ X $22\frac{1}{4}$		1
VERT PKT	X			HORZ PKT	X		
CARD HOLDER	X			DIAGONAL PKT	X		
COL	X			LABEL HOLDER	X		
EX. COL	X			GUSSETT	X		
	X			REINF.	X		
	X				X		

PRINTS

FRONT COVER	X	BACK BONE	X	BACK COVER	X
-------------	---	-----------	---	------------	---

BOARDS

	CODE	PT	PCS		CODE	PT	PCS
F.C. BOARD	$12\frac{3}{16}$ X $9\frac{13}{16}$	100	1	F.C. BOARD	$12\frac{5}{32}$ X $9\frac{23}{32}$	120	1
B.B. BOARD	$12\frac{3}{16}$ X $1\frac{11}{32}$	100	1	B.B. BOARD	$12\frac{5}{32}$ X $1\frac{11}{32}$	120	1
B.C. BOARD	$12\frac{3}{16}$ X $9\frac{13}{16}$	100	1	B.C. BOARD	$12\frac{5}{32}$ X $9\frac{23}{32}$	120	1
B. UP STRIP	X				X		
	X				X		

VRB

DIE # 5422		STYLE CASE angle d no booster		LOCATION E -2-7	
SHEET SIZE 12 3/8x10 1/2		CAP. 2		ORDER # 976210	
CUSTOMER INTEGRITY MOLD AND COMPANY				DUE DATE	
QUANTITY	100	RADIUS	3/8	TEAR SEAL	.014
DATE	9-21-93	COMPLETED		BAR SEAL	484

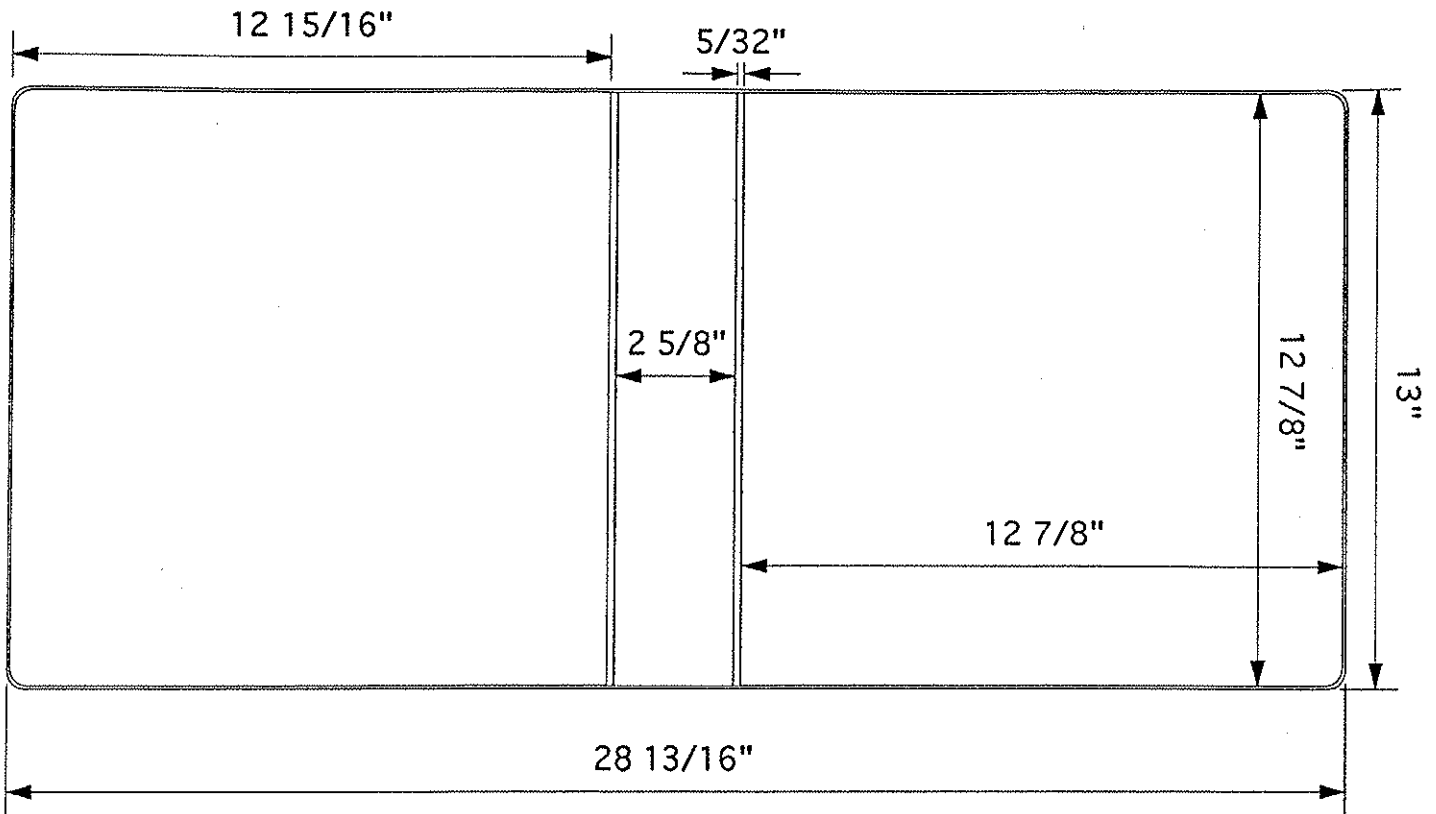

MATERIAL SPECS		GA PCS		GA PCS	
COVER MATL	13 3/4x29 9/16	1	LINING	13 3/4x29 9/16	1
COVER MATL			LINING		
VERT PKT			HORZ PKT		
VERT PKT			HORZPKT		
CARD HOLDER			DIAGONAL PKT		
COL			LABEL HOLDER		
EX COL			GUSSETT		
			REINF		

BOARD SPECS					
F.C. BOARD	12 25/32x12 25/32	120	1	F.C. BOARD	
B.B. BOARD	12 25/32x2 17/32	120	1	B.B. BOARD	
B.C. BOARD	12 25/32x12 25/32	120	1	B.C. BOARD	
BU STRIP					

NB Angle D

DIE # 5465		STYLE CASE VINYL RING BINDER		LOCATION	
SHEET SIZE 13 X 13		CAP. 1 1/2		ORDER # 976706	
CUSTOMER PRINTERS AND PUBLISHERS				DUE DATE	
QUANTITY	4500	RADIUS	3/8	TEAR SEAL	.014
DATE	11-22-93	COMPLETED		BAR SEAL	484

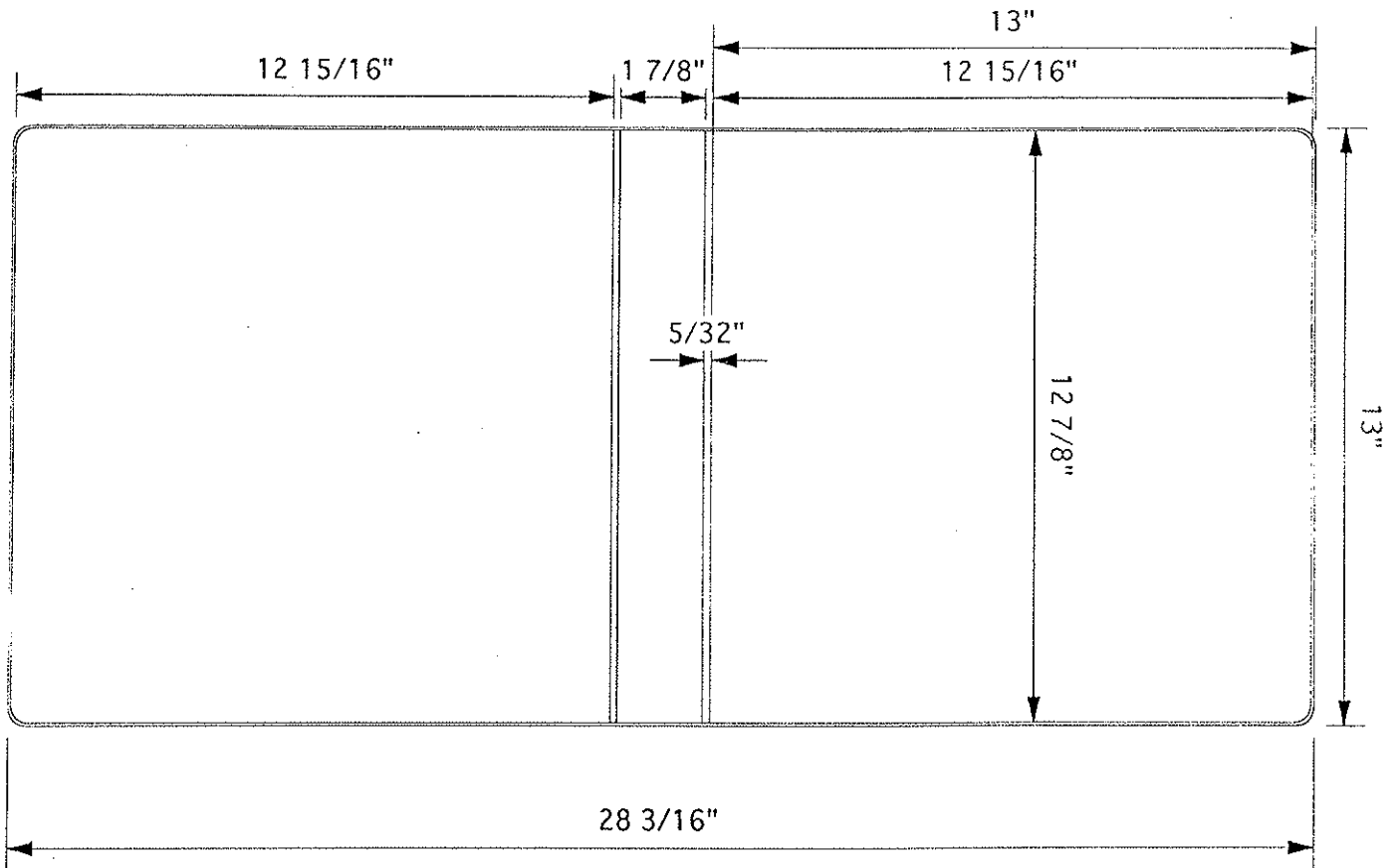

MATERIAL SPECS

GA PCS

GA PCS

COVER MATL	13 3/4 X 28 15/16		1	LINING	13 3/4 X 28 15/16	1
COVER MATL				LINING		
VERT PKT				HORZ PKT		
VERT PKT				HORZPKT	5 3/8 X 13 1/2	1
CARD HOLDER				DIAGONAL PKT		
COL <i>Pictorial</i>	13 3/4 X 28 15/16		1	LABEL HOLDER		
EX COL				GUSSETT		
				REINF		

BOARD SPECS

F.C. BOARD	12 25/32 X 12 27/32	120	1	F.C. BOARD		
B.B. BOARD	12 25/32 X 1 25/32	120	1	B.B. BOARD		
B.C. BOARD	12 25/32 X 12 27/32	120	1	B.C. BOARD		
BU STRIP						

DIE # 5629		STYLE CASE VINYL RING BINDER		LOCATION E 12-8	
SHEET SIZE 12 X 10 1/2		CAP. 1		ORDER # 978929	
CUSTOMER IVAN ALLEN				DUE DATE	
QUANTITY	500	RADIUS	3/8	TEAR SEAL	.012
DATE		COMPLETED		BAR SEAL	484

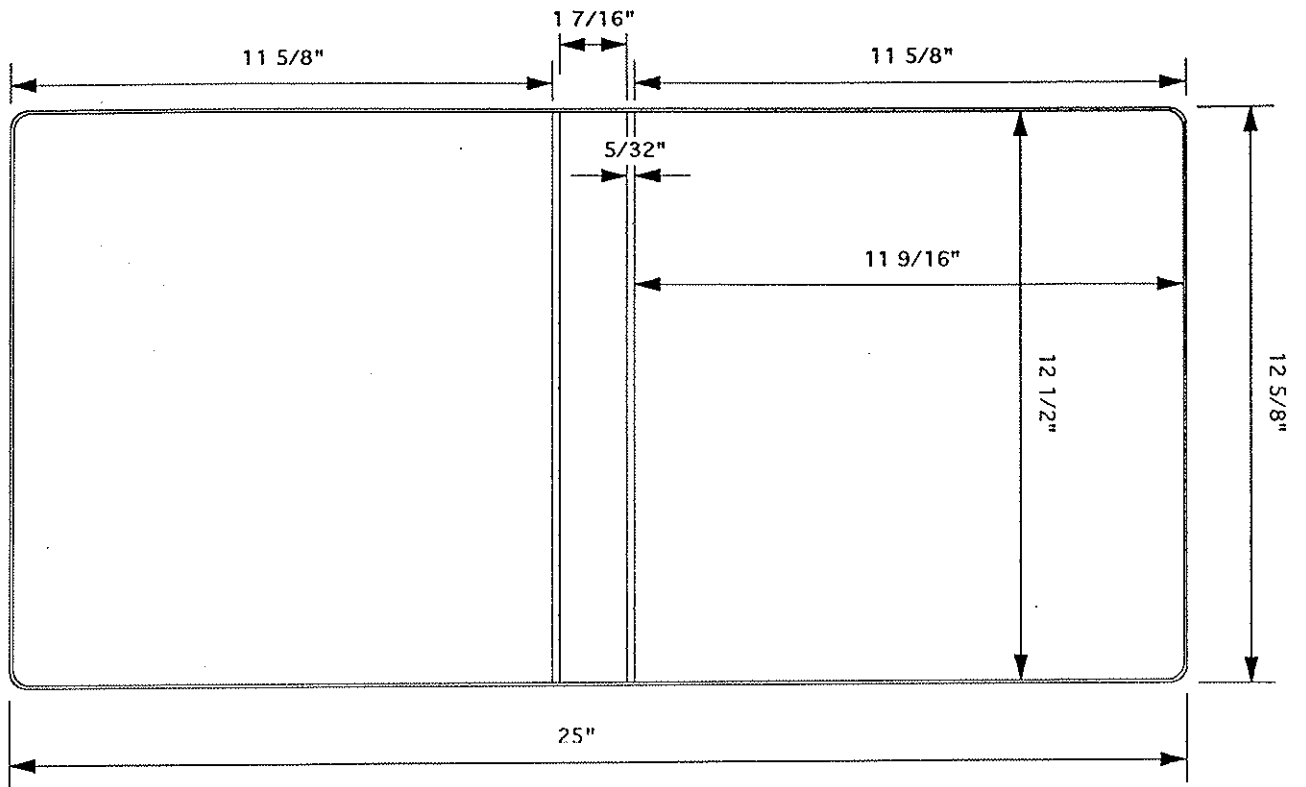

MATERIAL SPECS

GA PCS

GA PCS

COVER MATL	13 3/8 x 25 3/4	1	LINING	13 3/8 x 25 3/4	1
COVER MATL			LINING		
VERT PKT			HORZ PKT	5 3/8 x 25 3/4	1
VERT PKT			HORZPKT		
CARD HOLDER			DIAGONAL PKT		
COL			LABEL HOLDER		
EX COL			GUSSETT		
			REINF		

BOARD SPECS

F.C. BOARD	12 7/16 x 11 1/2	1	F.C. BOARD		
B.B. BOARD	12 7/16 x 1 11/32	1	B.B. BOARD		
B.C. BOARD	12 7/16 x 11 1/2	1	B.C. BOARD		
BU STRIP					

DIE #	5910	METAL	ROUND RING W/BOOSTER	RADIUS	3/8"
ORDER #	982566	CUSTOMER	P M A GROUP	TEAR SEAL	.014
SHEET SIZE	12 X 9 1/2	STYLE CASE	VINYL RING BINDER	BAR SEAL	48-4
CAP.	2 1/2	DUE DATE	10-02-95	COMPLETED	
LOCATION	F-14-5	QUANTITY	500	DATE	9-18-95

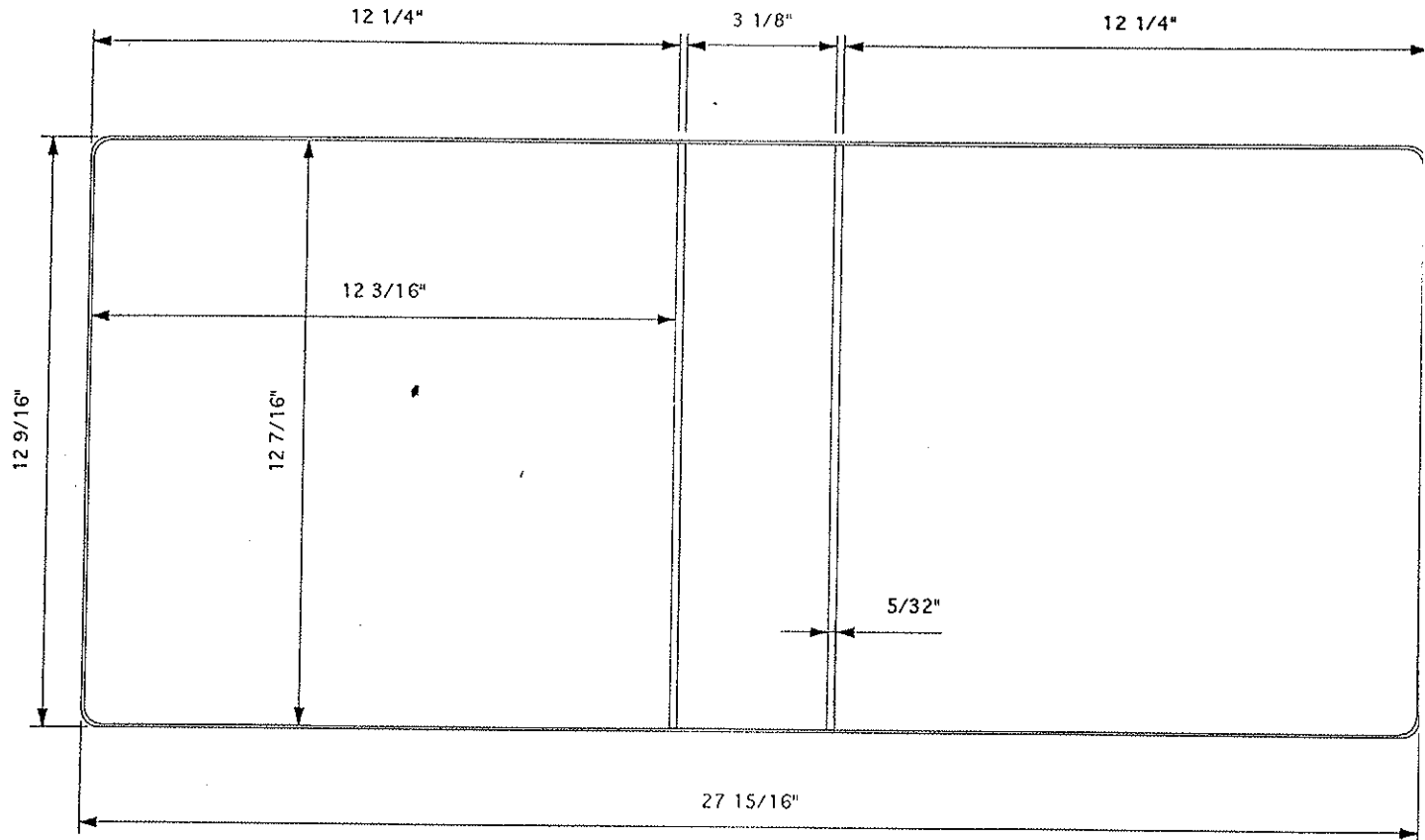

MATERIAL SPECS		GAUGE		MATERIAL SPECS		GAUGE	
COVER MAT.	13 5/16 X 28 3/4		1	LINING MAT.	13 5/16 X 28 3/4		
COVER MAT.				LINING MAT.			
DIE CUT				HORZ. PKT.	4 3/8 X 28 3/4		
COL				VERT. PKT.			
LABEL HOLDER				DIE CUT			
GUSSET				REINF.			

BOARD SPECS		GAUGE		BOARD SPECS		GAUGE	
F.C. BOARD	12 3/8 X 12 3/32	120	1	F.C. BOARD			
B.B. BOARD	12 3/8 X 3 1/32	120	1	B.B. BOARD			
B.G. BOARD	12 3/8 X 12 3/32	120	1	B.C. BOARD			
B.U. STRIP				DIE CUT			
DIE CUT				DIE CUT			

DIE #	5961	METAL	ANGLE D N/B	RADIUS	3/8
ORDER #	983092	CUSTOMER	VALVOLINE	TEAR SEAL	.014
SHEET SIZE	12 3/4 X 12 7/8	STYLE CASE	VRB	BAR SEAL	48-4
CAP.	1 1/2"	DUE DATE	12-11-95	COMPLETED	
LOCATION	L-6-7	QUANTITY	520	DATE	11-28-95

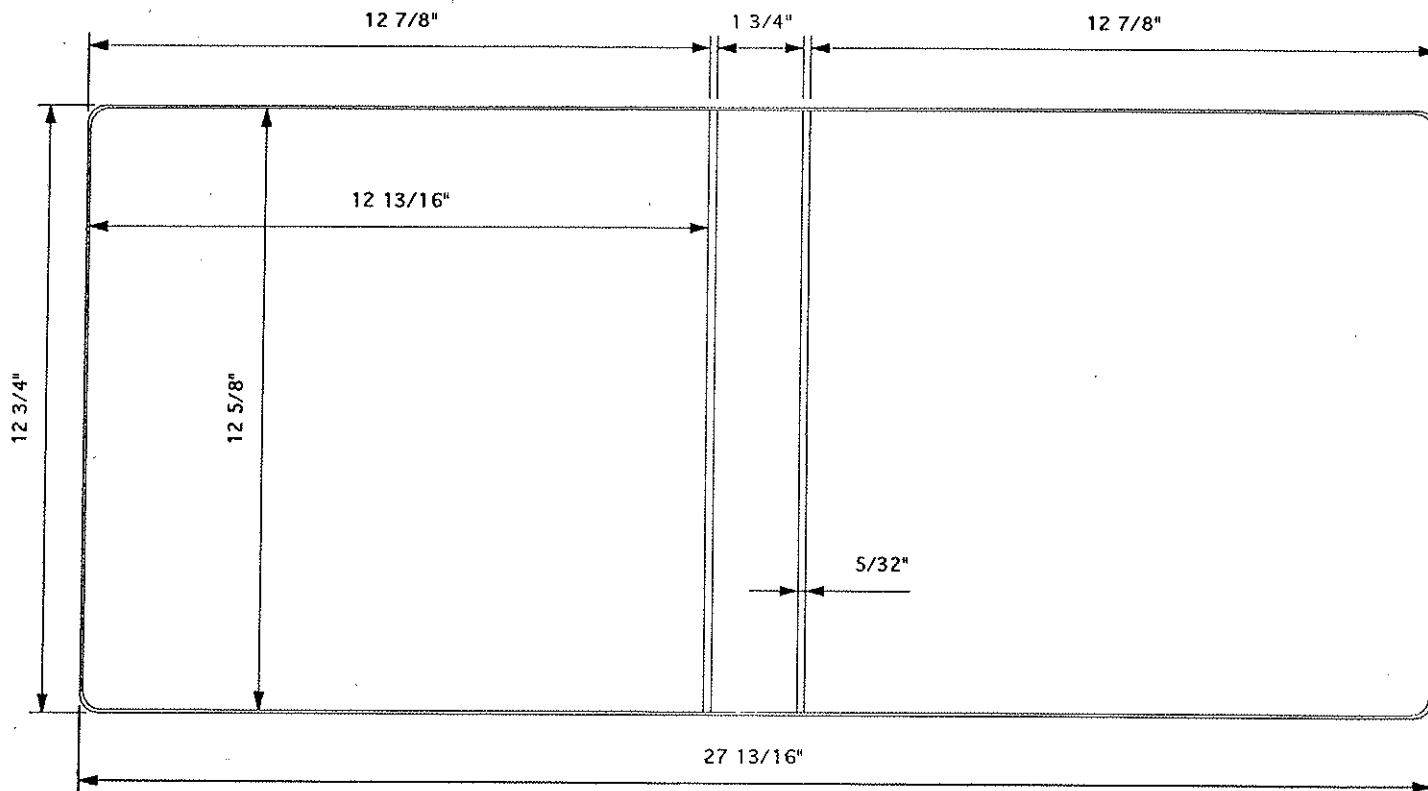

MATERIAL SPECS		GAUGE		MATERIAL SPECS		GAUGE	
COVER MAT.	13 1/2 X 28 5/8		1	LINING MAT.	13 1/2 X 28 5/8		1
PICTORIAL	13 1/2 X 28 5/8		1	LINING MAT.			
DIE CUT				HORZ. PKT.	5 3/8 X 28 5/8		1
COL				VERT. PKT.			
LABEL HOLDER				DIE CUT			
GUSSET				REINF.			
BOARD SPECS		GAUGE		BOARD SPECS		GAUGE	
F.C. BOARD	12 9/16 X 12 3/4	100	1	F.C. BOARD			
B.B. BOARD	12 9/16 X 1 21/32	100	1	B.B. BOARD			
B.C. BOARD	12 9/16 X 12 3/4	100	1	B.C. BOARD			
B.U. STRIP				DIE CUT			
DIE CUT				DIE CUT			

DIE #	5966	METAL	ANGLE D	RADIUS	3/8"
ORDER #	983260	CUSTOMER	CETLIN DESIGN GROUP	TEAR SEAL	.014
SHEET SIZE	12 X 10 3/4	STYLE CASE	VRB	BAR SEAL	253
CAP.	1"	DUE DATE	12-8-95	COMPLETED	
LOCATION	L-6-2	QUANTITY	1	DATE	12-6-95

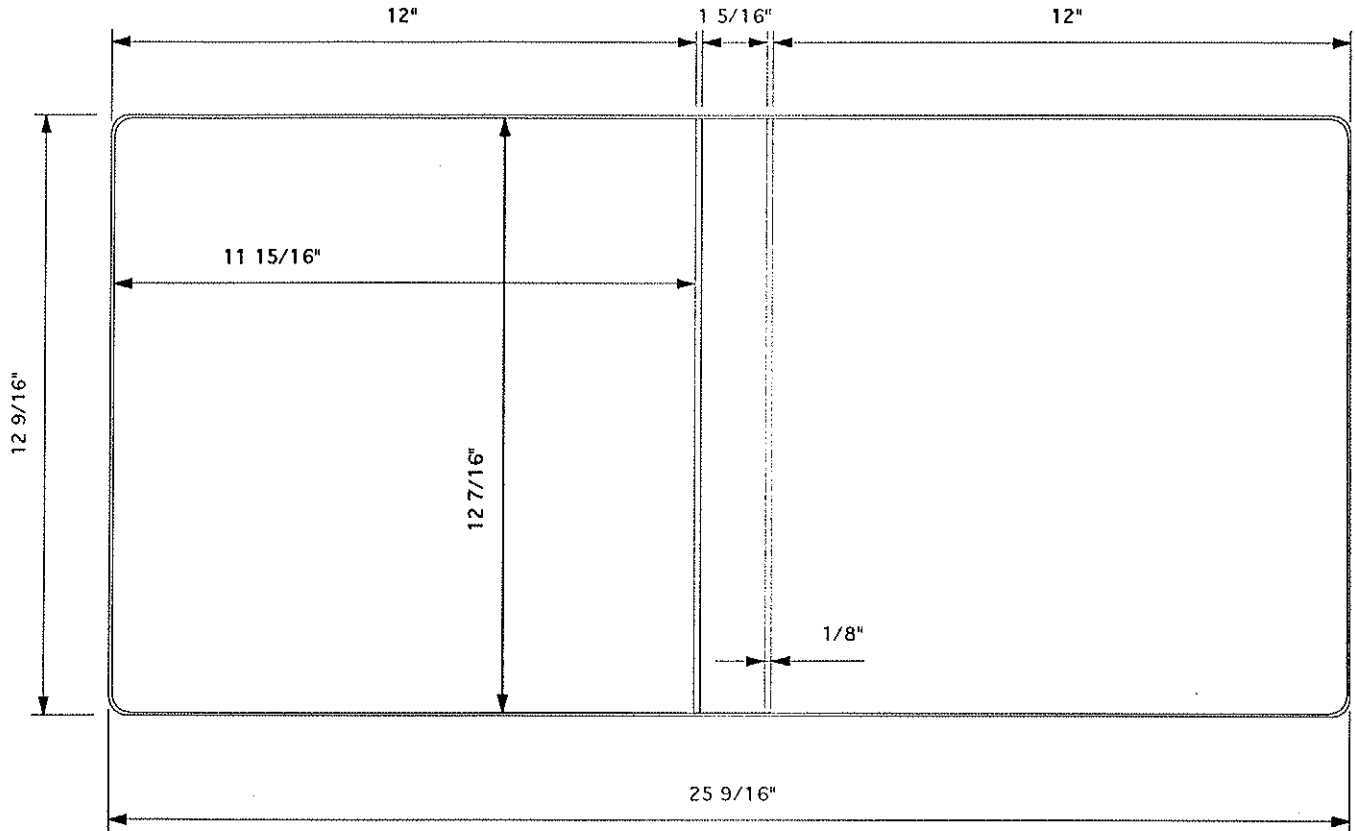

MATERIAL SPECS		GAUGE		MATERIAL SPECS		GAUGE	
COVER MAT.	13 1/4 X 26 1/4		1	LINING MAT.	13 1/4 X 26 1/4		1
COVER MAT.				LINING MAT.			
DIE CUT				HORZ. PKT.			
COL				VERT. PKT.			
LABEL HOLDER				DIE CUT			
GUSSET				REINF.			

BOARD SPECS		GAUGE		BOARD SPECS		GAUGE	
F.C. BOARD	12 3/8 X 11 7/8	100	1	F.C. BOARD	12 11/32 X 11 27/32	120	1
B.B. BOARD	12 3/8 X 1 7/32	100	1	B.B. BOARD	12 3/8 X 1 7/32	120	1
B.C. BOARD	12 3/8 X 11 7/8	100	1	B.C. BOARD	12 11/32 X 11 27/32	120	1
B.U. STRIP				DIE CUT			
DIE CUT				DIE CUT			

DIE #	6185	METAL	3" ANGLE D NB	RADIUS	3/8"
ORDER #	986310	CUSTOMER	REED TOOL COMPANY	TEAR SEAL	.014
SHEET SIZE	12 X 9 1/2	STYLE CASE	VINYL RING BINDER	BAR SEAL	253
CAP.	3"	DUE DATE	1-30-97	COMPLETED	
LOCATION	G-1-2	QUANTITY	250	DATE	1-21-9

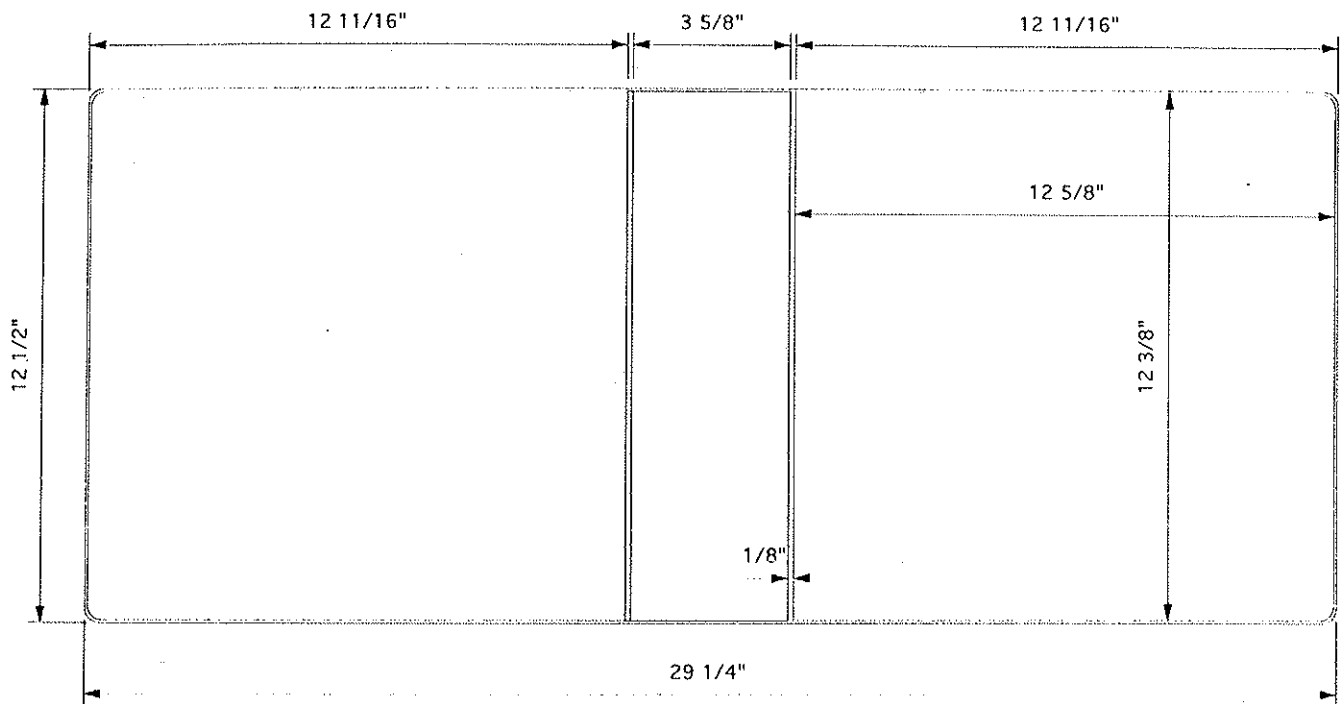

MATERIAL SPECS		GAUGE		PCS.		MATERIAL SPECS		GAUGE	
COVER MAT.	13 1/4 X 30			1		LINING MAT.	13 1/4 X 30		
COVER MAT.						LINING MAT.			
DIE CUT						HORZ. PKT.	5 3/8 X 30		
COL	12 5/8 X 17 3/8			1		VERT. PKT.			
LABEL HOLDER						DIE CUT			
GUSSET						REINF.	12 1/4 X 4 7/8		SKRIM

BOARD SPECS		GAUGE		PCS.		BOARD SPECS		GAUGE	
F.C. BOARD	12 9/32 X 12 17/32			1		F.C. BOARD			
B.B. BOARD	12 9/32 X 3 17/32			1		B.B. BOARD			
B.C. BOARD	12 9/32 X 12 17/32			1		B.C. BOARD			
FLAP BD.						DIE CUT			
BOARD						DIE CUT			

DIE #	6208	METAL	STR D NB	RADIUS	3/8"
ORDER #	986570	CUSTOMER	INTERNATIONAL PAPER	TEAR SEAL	.014
SHEET SIZE	12 1/4 X 10 1/8	STYLE CASE	VINYL RING BINDER	BAR SEAL	48-8
CAP.	1"	DUE DATE	2-27-97	COMPLETED	
LOCATION	H-6-3	QUANTITY	50	DATE	2-20-97

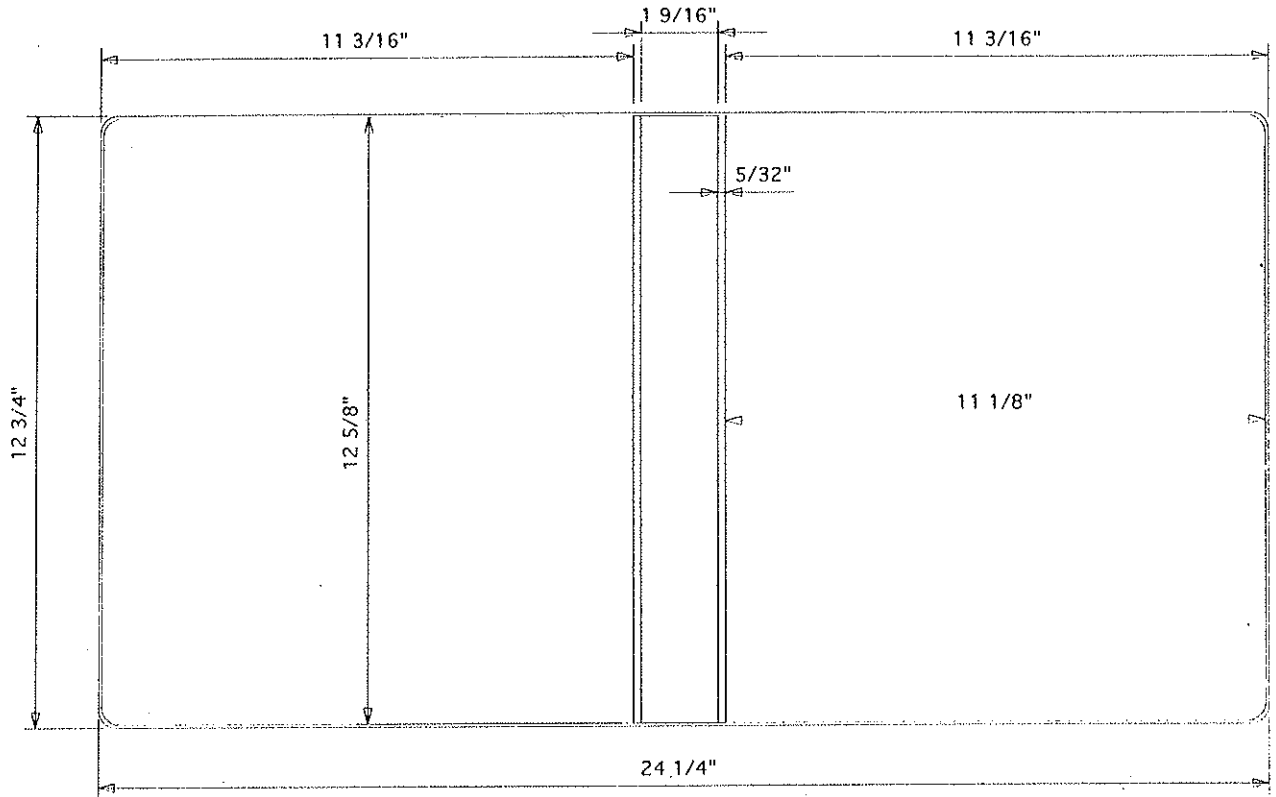

MATERIAL SPECS		GAUGE		MATERIAL SPECS		GAUGE	
COVER MAT.	13 3/4 X 25 1/4		1	LINING MAT.	13 1/2 X 25		
COVER MAT.				LINING MAT.			
DIE CUT				HORZ. PKT.	5 3/8 X 25		
COL				VERT. PKT.			
LABEL HOLDER				DIE CUT			
GUSSET				REINF.			

BOARD SPECS		GAUGE		BOARD SPECS		GAUGE	
F.C. BOARD	12 9/16 X 11 1/16	100	1	F.C. BOARD			
B.B. BOARD	12 9/16 X 1 15/32	100	1	B.B. BOARD			
B.C. BOARD	12 9/16 X 11 1/16	100	1	B.C. BOARD			
FLAP BD.				DIE CUT			
BOARD				DIE CUT			

DIE #	6294	METAL	2 - 4" CLIPS	RADIUS	1/4"
ORDER #	987444	CUSTOMER	HOME INTERIORS	TEAR SEAL	.014
SHEET SIZE	12 1/4 X 13	STYLE CASE	VINYL CLIP BINDER	BAR SEAL	253
CAP.	5/8"	DUE DATE	8-13-97	COMPLETED	
LOCATION	H-1-9	QUANTITY	6000	DATE	7-24-97

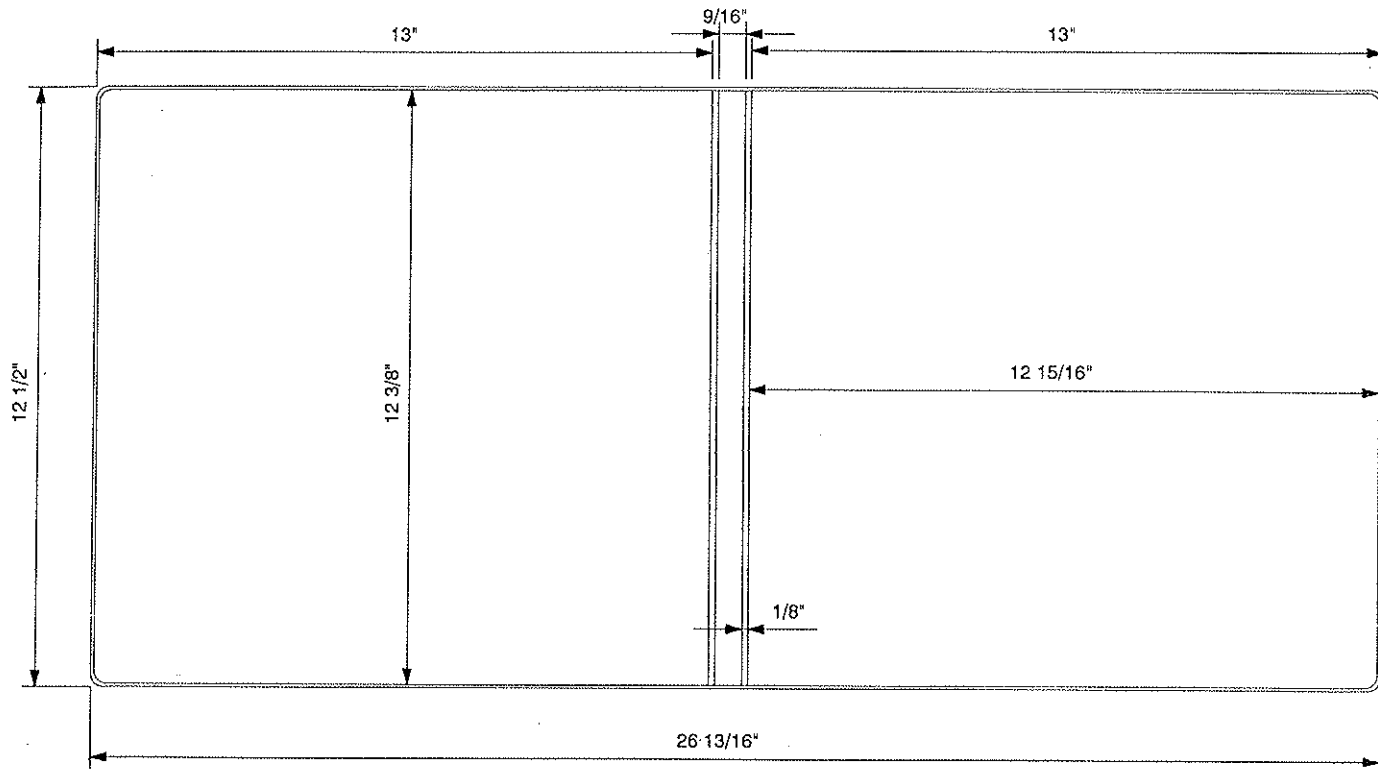

MATERIAL SPECS		GAUGE PCS.		MATERIAL SPECS		GAUGE	
COVER MAT.	13 1/4 X 27 1/2		1	LINING MAT.	13 1/4 X 27 1/2		
COVER MAT.				LINING MAT.			
DIE CUT				HORZ. PKT.			
COL				VERT. PKT.			
LABEL HOLDER				DIE CUT			
GUSSET				REINF.			

BOARD SPECS		GAUGE PCS.		BOARD SPECS		GAUGE	
F.C. BOARD	12 9/32 X 12 27/32	125	1	F.C. BOARD			
B.B. BOARD	12 9/32 X 15/32	125	1	B.B. BOARD			
B.C. BOARD	12 9/32 X 12 27/32	125	1	B.C. BOARD			
FLAP BD.				DIE CUT			
BOARD				DIE CUT			

DIE #	7417	METAL	STR D.	RADIUS	3/8"
ORDER #	550256	CUSTOMER	VISUAL HORIZONS	TEAR SEAL	.014
SHEET SIZE	12 X 16 1/2 OA	STYLE CASE	VRB (PER CUST. SPECS)	BAR SEAL	48-4
CAP.	1"	DUE DATE	4-14-03	COMPLETED	
LOCATION		QUANTITY	1	DATE	4-9-03

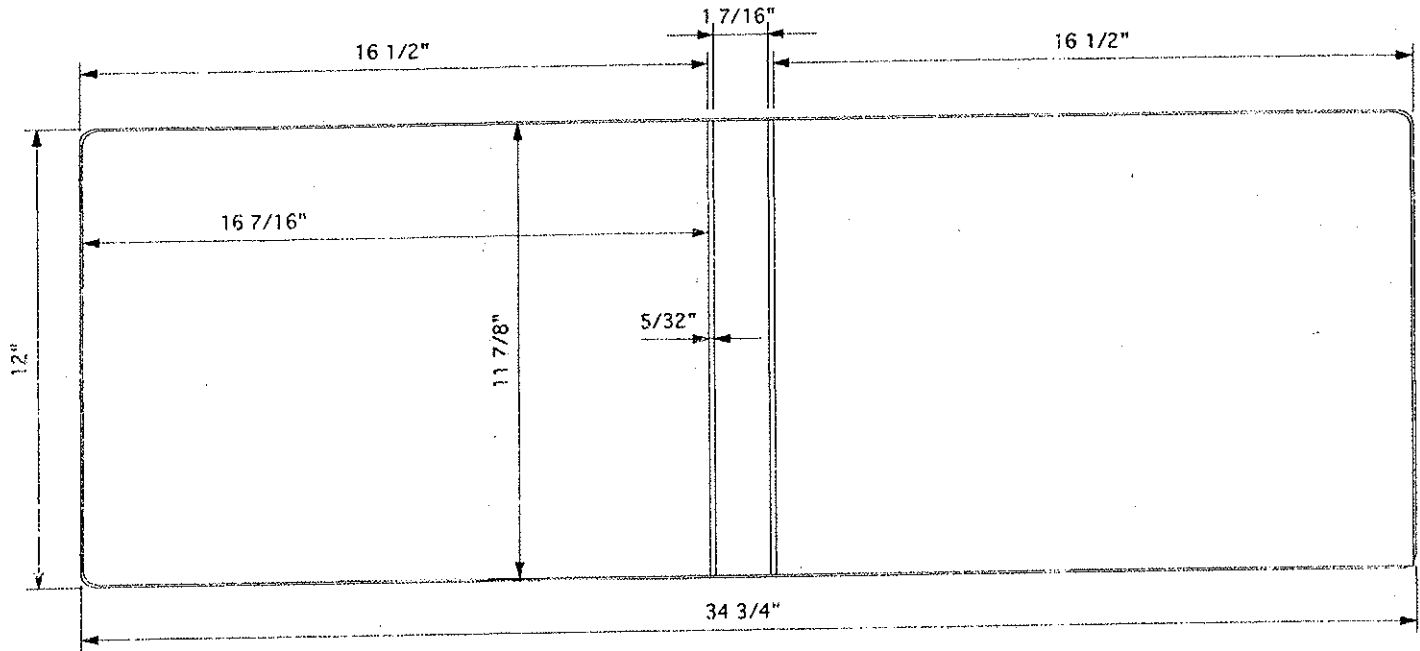

MATERIAL SPECS		GAUGE	PCS.	MATERIAL SPECS	GAUGE	PCS.	
COVER MAT.	13 X 35 3/4		1	LINING MAT.	12 3/4 X 35 1/2	1	
COVER MAT.				LINING MAT.			
DIE CUT				HORZ. PKT.			
COL				VERT. PKT.			
LABEL HOLDER				DIE CUT			
GUSSET				REINF.			
BOARD SPECS	5/16" R. CORNERS	GAUGE	PCS.	BOARD SPECS	5/16" R. CORNERS	GAUGE	PCS.
F.C. BOARD	11 25/32 X 16 11/32	100	1	F.C. BOARD			
B.B. BOARD	11 25/32 X 1 11/32	100	1	B.B. BOARD			
B.C. BOARD	11 25/32 X 16 11/32	100	1	B.C. BOARD			
FLAP BD.				DIE CUT			
BOARD	11 25/32 X 16 11/32	35	1	DIE CUT			

DIE #	7441	METAL	ANGLE D	RADIUS	3/8"
ORDER #	556463	CUSTOMER	WILSONART	TEAR SEAL	.014
SHEET SIZE	12 X 11 1/2	STYLE CASE	VINYL BINDER	BAR SEAL	48-4
CAP.	1"	DUE DATE	6-6-03	COMPLETED	
LOCATION		QUANTITY	1000	DATE	5-16-03

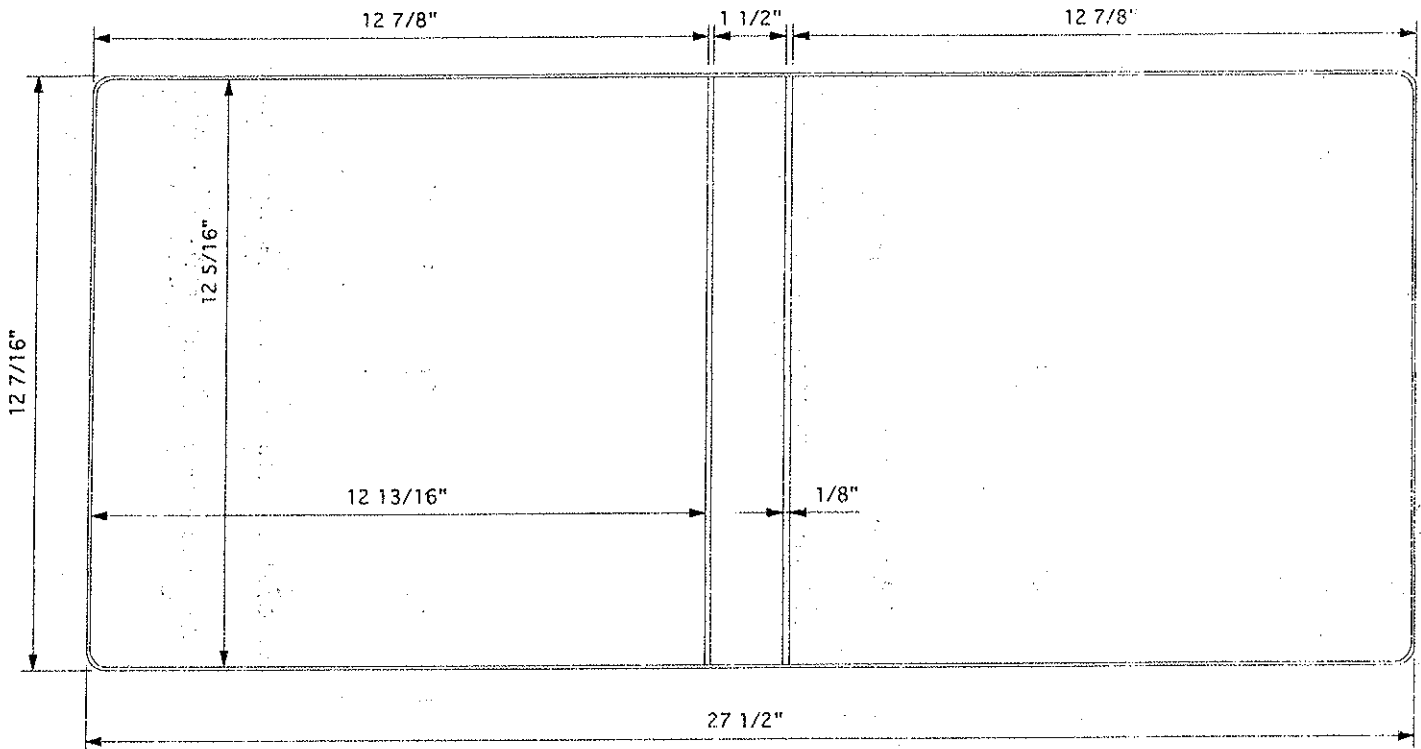

MATERIAL SPECS		GAUGE	PCS.	MATERIAL SPECS		GAUGE	PCS.
COVER MAT.	13 3/16 X 28 1/4		1	LINING MAT.	13 3/16 X 28 1/4		1
COVER MAT.				LINING MAT.			
DIE CUT				HORZ. PKT.			
COL	12 9/16 X 13 3/8		1	VERT. PKT.			
LABEL HOLDER				DIE CUT			
GUSSET				REINF.			
BOARD SPECS		5/16" R. CORNERS		GAUGE	PCS.	BOARD SPECS	
F.C. BOARD	12 1/4 X 12 3/4	118	1	F.C. BOARD		5/16" R. CORNERS	GAUGE PCS.
B.B. BOARD	12 1/4 X 1 13/32	118	1	B.B. BOARD			
B.C. BOARD	12 1/4 X 12 3/4	118	1	B.C. BOARD			
FLAP BD.				DIE CUT			
BOARD				DIE CUT			

ORDER # 7579
 ORDER # 589716
 SHEET SIZE 12.5 X 16 OA
 CAP 2"
 LOCATION

ORDER STR D
 ORDER # CAMELOT SAMPLE GROUP
 STYLE CASE VRB
 DUE DATE 11-25-03
 QUANTITY 100

PART # 3/8"
 LEAD SEAL .014
 BAG SEAL 48-4
 COMPLETE DATE
 DATE 11-20-03

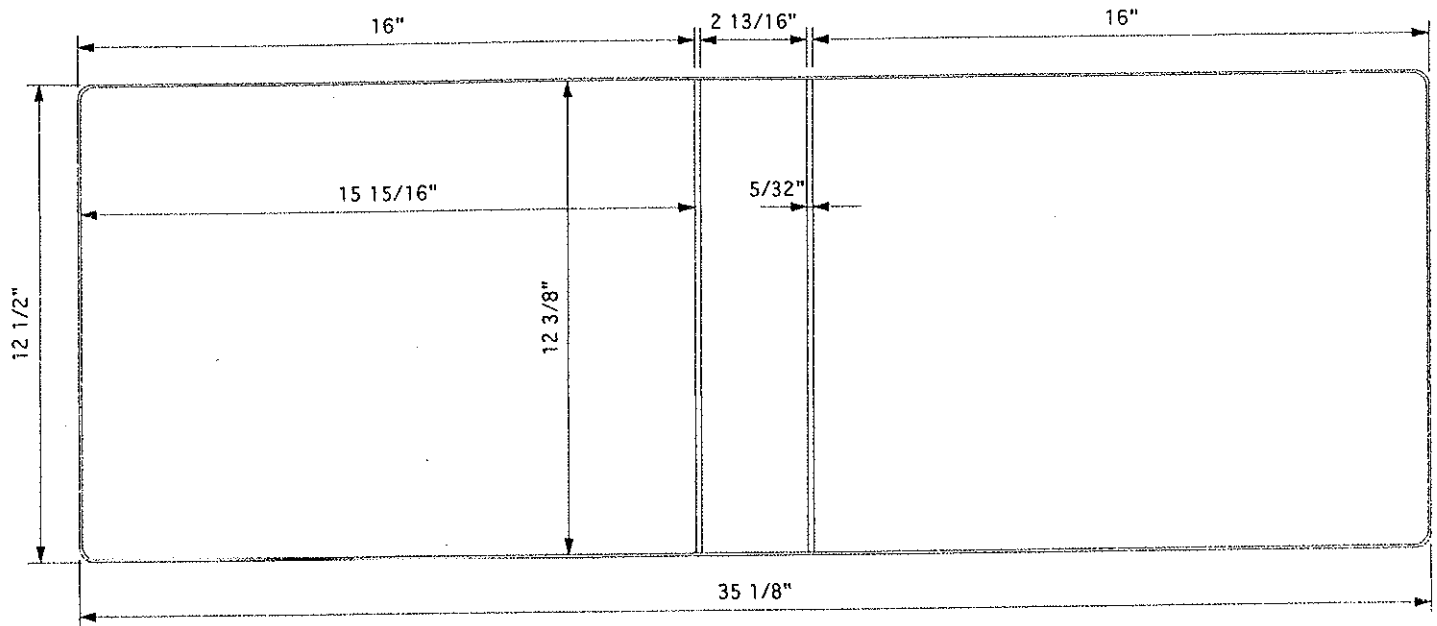

ITEM	DESCRIPTION	QTY	UNIT	ITEM	DESCRIPTION	QTY	UNIT
COVER MAT	13 1/4 X 35 7/8	1		LINING MAT	13 1/4 X 35 7/8	1	
COVER MAT				LINING MAT			
DEVELOP				NOSE LIFT	5 3/8 X 35 7/8	1	
COL.	12 5/8 X 20 3/8	1		SEAT PKY			
CAMELOT BUSH				SEAL KIT			
EXHAUST				SEAL			
SEAL				SEAL			
SEAL	12 5/16 X 15 7/8	118	1	SEAL			
SEAL	12 5/16 X 2 23/32	118	1	SEAL			
SEAL	12 5/16 X 15 7/8	118	1	SEAL			

DIE #	8202	METAL	ANGLE D	RADIUS	3/8"
ORDER #	754216	CUSTOMER	UNIFIED RESOURCES	TEAR SEAL	.014
SHEET SIZE	12 X 9 1/2	STYLE CASE	VINYL BINDER	BAR SEAL	48-4
CAP.	4"	DUE DATE	9-29-06	COMPLETED	
LOCATION		QUANTITY	200	DATE	9-25-06

*** WARNING DRAWING NOT ACTUAL SIZE ***

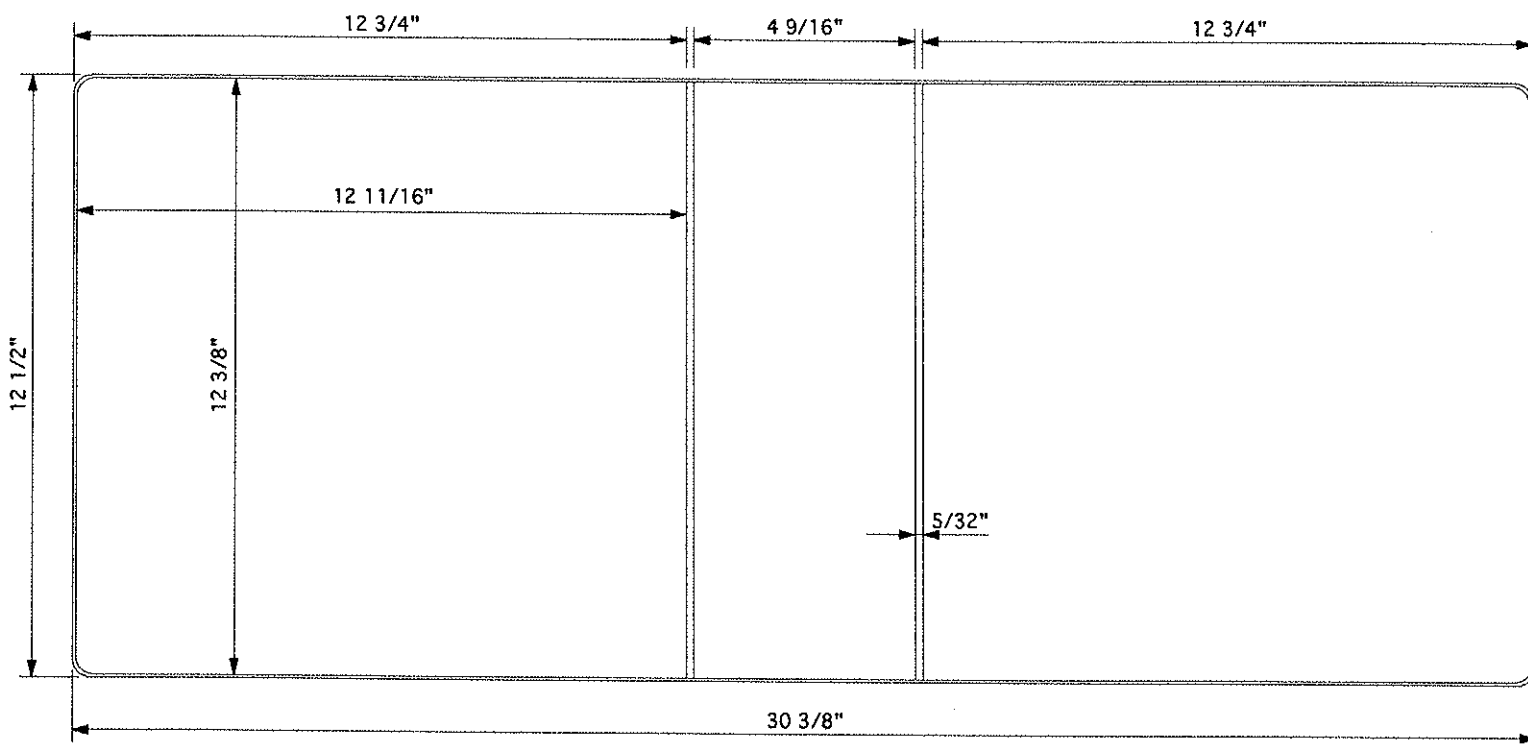

MATERIAL SPECS		GAUGE	PCS.	MATERIAL SPECS		GAUGE	PCS.				
COVER MAT.	13 1/4 X 31 1/8		1	LINING MAT.	13 1/4 X 31 1/8		1				
COVER MAT.				LINING MAT.							
DIE CUT				HORZ. PKT.							
COL				VERT. PKT.							
LABEL HOLDER				DIE CUT							
GUSSET				REINF.							
BOARD SPECS		5/16" R. CORNERS		GAUGE	PCS.	BOARD SPECS		5/16" R. CORNERS		GAUGE	PCS.
F.C. BOARD	12 5/16 X 12 5/8	120	1	F.C. BOARD							
B.B. BOARD	12 5/16 X 4 15/32	120	1	B.B. BOARD							
B.C. BOARD	12 5/16 X 12 5/8	120	1	B.C. BOARD							
FLAP BD.				DIE CUT							
BOARD				DIE CUT							

DIE #	8714-R	METAL	RR NB	RADIUS	3/8"
ORDER #	897735	CUSTOMER	SUSIE FORRESTER	TEAR SEAL	.014
SHEET SIZE	13 x 14	STYLE CASE	VRB	BAR SEAL	48-4
CAP.	2"	DUE DATE	6-30-09	COMPLETED	
LOCATION		QUANTITY	50	DATE	6-13-09

*** WARNING DRAWING NOT ACTUAL SIZE ***

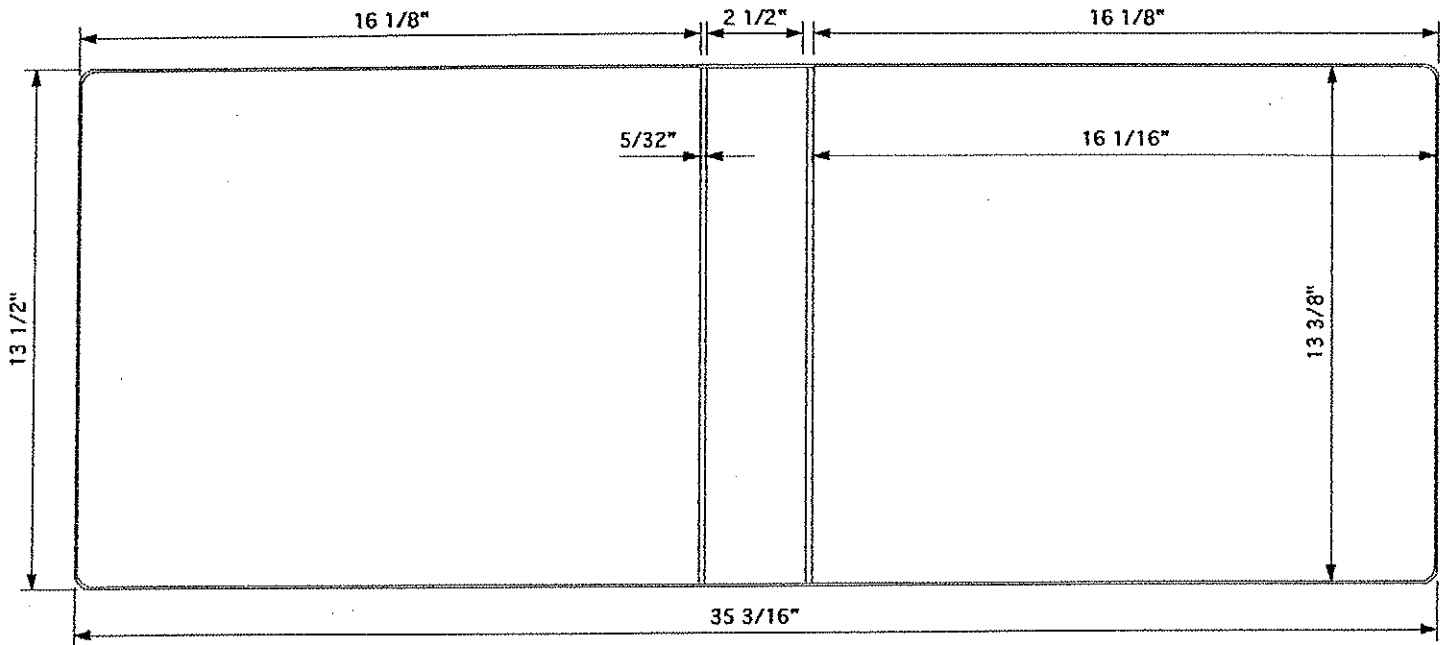

MATERIAL SPECS		GAUGE	PCS.	MATERIAL SPECS		GAUGE	PCS.				
COVER MAT.	14 1/4 X 36		1	LINING MAT.	14 1/4 X 36		1				
COVER MAT.				LINING MAT.							
DIE CUT				HORZ. PKT.							
COL				VERT. PKT.							
LABEL HOLDER				DIE CUT							
GUSSET				REINF.							
BOARD SPECS		5/16" R. CORNERS		GAUGE	PCS.	BOARD SPECS		5/16" R. CORNERS		GAUGE	PCS.
F.C. BOARD	13 5/16 X 16	119	1	F.C. BOARD							
B.B. BOARD	13 5/16 X 2 13/32	119	1	B.B. BOARD							
B.C. BOARD	13 5/16 X 16	119	1	B.C. BOARD							
FLAP BD.				DIE CUT							
BOARD				DIE CUT							