

Product Code

Style Case *Angle D Ring*

Sheet Size *11 X 9*

Cap. *1 1/2* Die No. *3667*

Order No. *953680*

Plate

Customer

Harris Corp.

Metal
Total Vinyl <i>1030</i>
Quantity <i>500</i>
Date <i>11-20-86</i>
Type Corners <i>R</i>
Radius <i>1/4</i>
Completed

	Gauge	Thick
Tear Seal	<i>.016</i>	<i>3/32</i>
Bar Seal	<i>72</i>	<i>1/8</i>
Bar Seal		

	No. of Feet
Tear Seal	
Bar Seal	
Bar Seal	

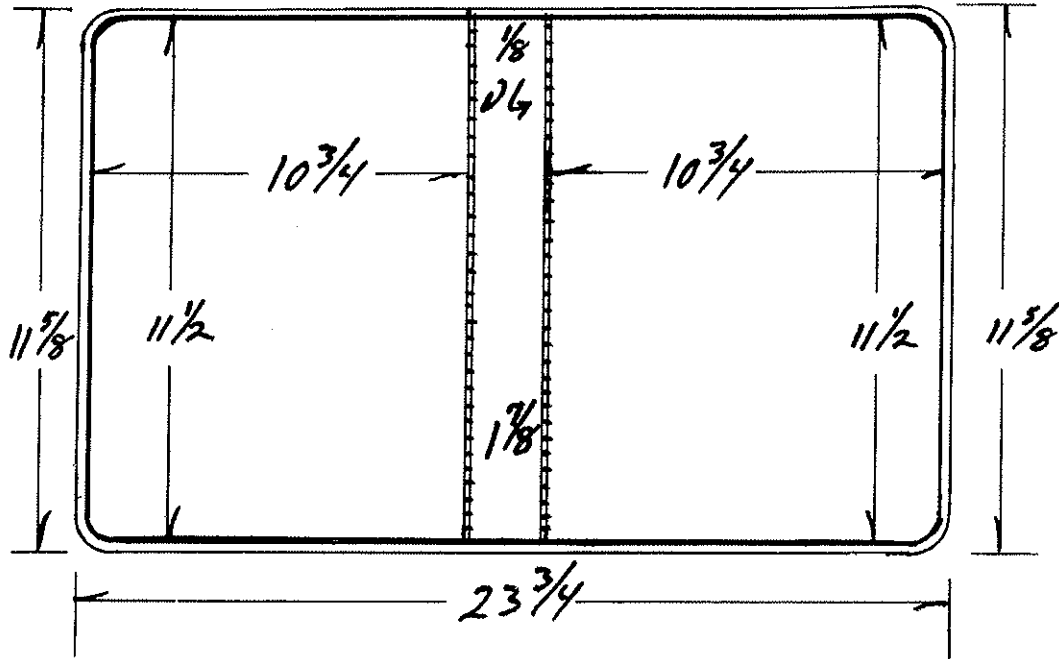

Code	Ga.	#	Cutting Specs		Code	Ga.	#	Cutting Specs	
			Size	Out				Size	Out
Cover Mat.			<i>12 1/4 X 24 3/8</i>	<i>1</i>	Lining Mat.			<i>12 1/4 X 24 3/8</i>	<i>1</i>
Cover Mat.			X		Lining Mat.			X	
Vert. Pckt.			X		Horz. Pckt.			<i>7 X 13 1/4</i>	<i>1</i>
Vert. Pckt.			X		Horz. Pckt.			X	
Pocket			X		Pocket			X	
Label Holder			X		Card Hlder			X	
Material			X		Material			X	
Material			X		Material			X	
Material			X		Material			X	
F.C. Board			<i>11 13/32 X 10 21/32</i>	<i>100 1</i>	B.C. Board			<i>11 13/32 X 10 21/32</i>	<i>100 1</i>
B.C. Board			<i>11 7/16 X 10 11/16</i>	<i>100 2</i>	B.B. Board			<i>11 13/32 X 1 25/32</i>	<i>120 1</i>
Center Board			<i>11 7/16 X 1 25/32</i>	<i>100 1</i>	Board			X	
Board			X		Strip			X	
Cover Pad			X		Strip			X	
					B.B. Pad			X	

Product Code

Style Case *Angle D* *USP*

Sheet Size *11* X *9*

Cap. *2 1/2* Die No. *3727*

Order No. *954277*

Plate

Customer

Harris Corporation

Metal
Total Vinyl <i>1030</i>
Quantity <i>500</i>
Date <i>1-30-87</i>
Type Corners <i>RD</i>
Radius <i>1/4</i>
Completed

	Gauge	Thick
Tear Seal	<i>10/16</i>	<i>1 Pt.</i>
Bar Seal	<i>92</i>	<i>1/8</i>
Bar Seal		

	No. of Feet
Tear Seal	
Bar Seal	
Bar Seal	

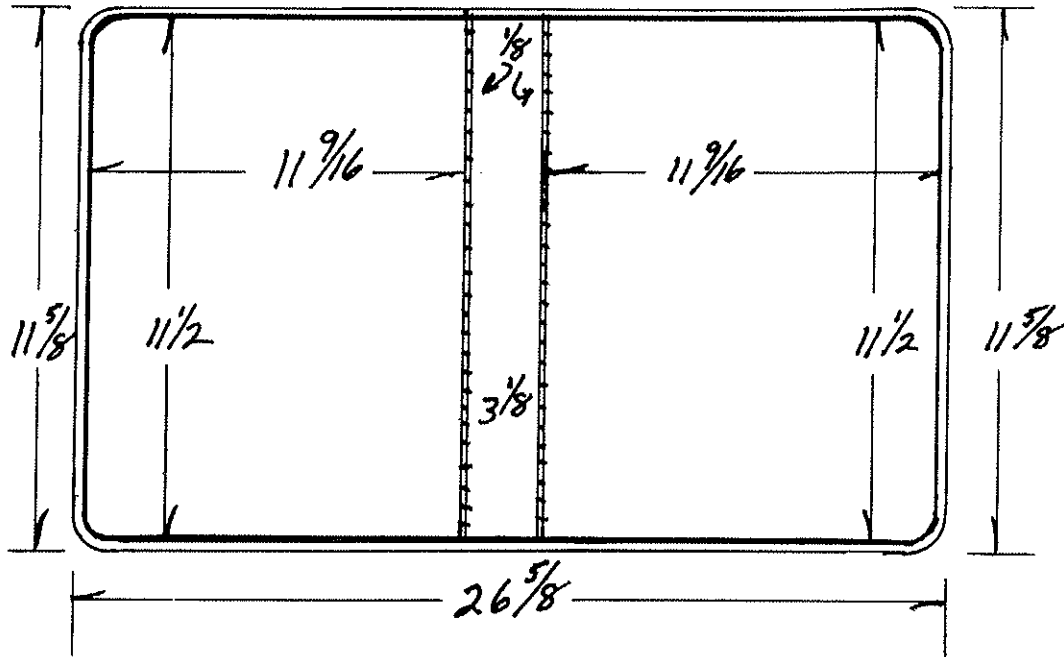

Code	Ga.	PCS	Cutting Specs		Code	Ga.	Pcs.	Cutting Specs	
			Size	Out				Size	Out
Cover Mat.		<i>1</i>	<i>12 1/4 X</i>	<i>27 1/4</i>	Lining Mat.		<i>1</i>	<i>12 1/4 X</i>	<i>27 1/4</i>
Cover Mat.			X		Lining Mat.			X	
Vert. Pckt.			X		Horz. Pckt.		<i>1</i>	<i>11 11/16 X</i>	<i>15 5/16</i>
Vert. Pckt.			X		Horz. Pckt.			X	
Pocket			X		Pocket			X	
Label Holder			X		Card Holder			X	
Material			X		Material			X	
Material			X		Material			X	
Material			X		Material			X	
F.C. Board		<i>1</i>	<i>11 13/32 X</i>	<i>11 15/32</i>	B.C. Board		<i>1</i>	<i>11 13/32 X</i>	<i>11 15/32</i>
B.C. Board			X		B.B. Board		<i>1</i>	<i>11 13/32 X</i>	<i>3 1/32</i>
Center Board			X		Board			X	
Board			X		Strip			X	
Cover Pad			X		Strip			X	
					B.B. Pad			X	

Product Code LEONARD ANGLE D

Style Case RING BINDER

Sheet Size 11 X 9

Cap. 1

Die No. 3781

Order No. 954999

Plate

Customer AVIATOR INTERNATIONAL INC.

Metal
Total Vinyl .030
Quantity 100
Date 4-6-87
Type Corners Rd
Radius 1/4
Completed

	Gauge	Thick
Tear Seal	.016	3/32
Bar Seal	1/8	3/16
Bar Seal		

	No. of Feet
Tear Seal	
Bar Seal	
Bar Seal	

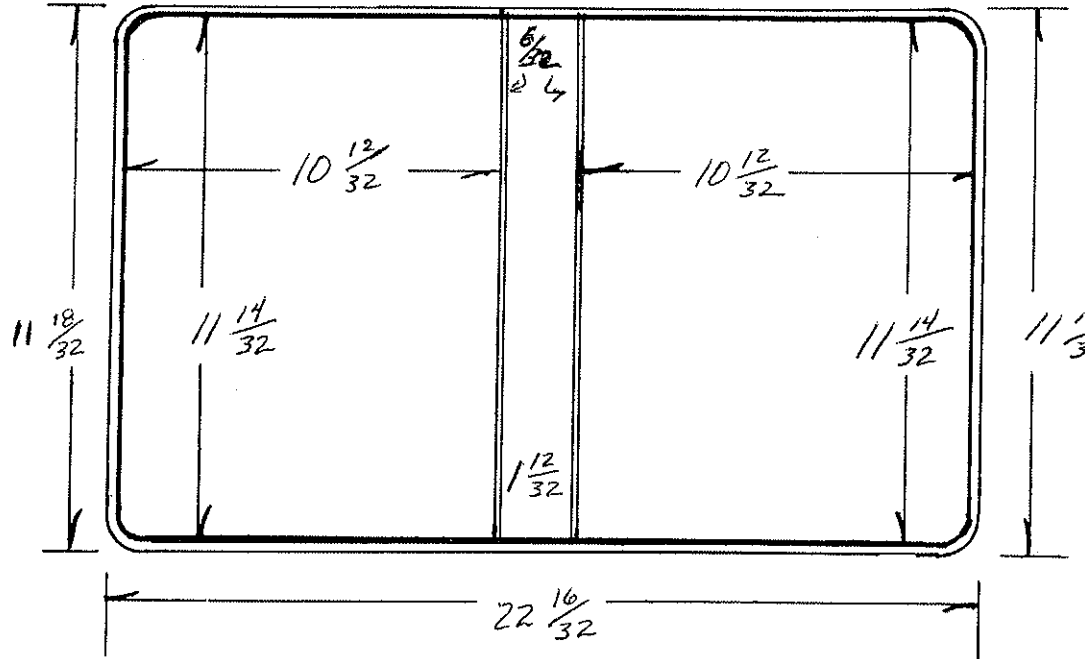

RC:
Copied by HP 1-4-90
Converted

Code	Ga.	# PCS	Cutting Specs		Code	Ga.	# Pcs.	Cutting Specs	
			Size	Out				Size	Out
Cover Mat.		1	12 1/4	X 23 1/4	Lining Mat.		1	12 1/4	X 23 1/4
Cover Mat				X	Lining Mat.				X
Vert. Pckt.				X	Horz. Pckt.			5 3/8	X 10 7/8
Vert. Pckt.				X	Horz. Pckt.		1	5 3/8	X 23 1/4
Pocket				X	Pocket	COL	1	11 1/16	X 23 1/4
Label Holder				X	Card Holder				X
Material				X	Material				X
Material				X	Material				X
Material				X	Material				X
F.C. Board		1	11 1/32	X 10 9/32	B.C. Board		1	11 1/32	X 10 9/32
B.C. Board				X	B.B. Board		1	11 1/32	X 1 9/32
Center Board				X	Board				X
Board				X	Strip				X
Cover Pad				X	Strip				X
					B.B. Pad				X

Product Code

Style Case Advantage - D

Sheet Size

11 X 9

Cap. 3

Die No. 3851

Order No. 1000092

Plate

Customer

John Hancock

Metal
Total Vinyl
Quantity <u>1</u>
Date
Type Corners <u>Rd</u>
Radius <u>1/4</u>
Completed

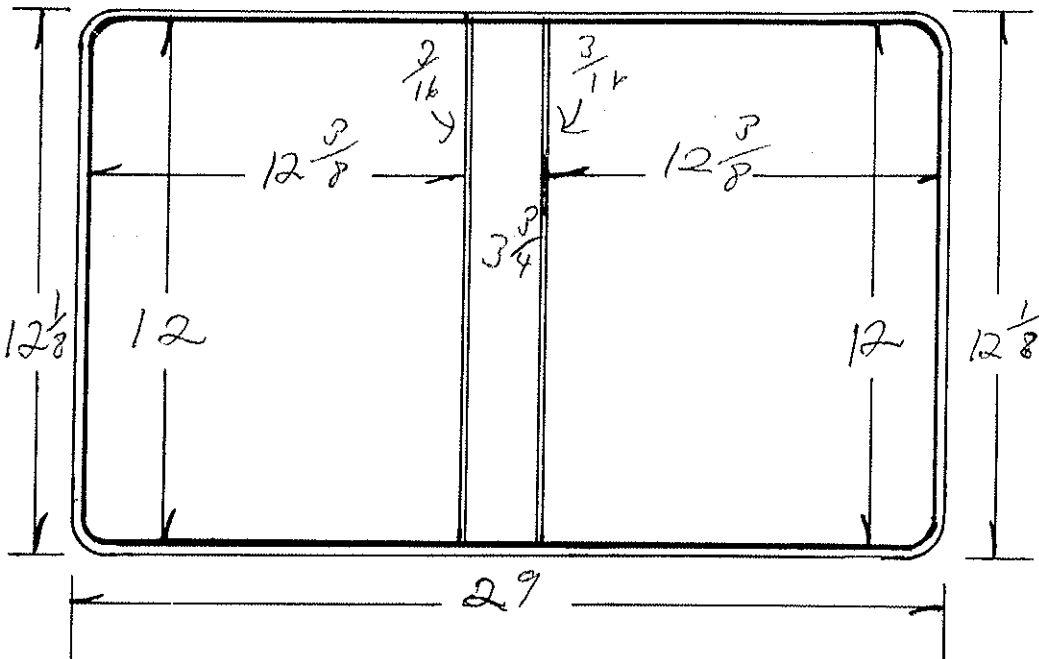

Gauge	Thick
Tear Seal <u>107</u>	<u>16</u>
Bar Seal <u>0/16</u>	
Bar Seal	

No. of Feet
Tear Seal
Bar Seal
Bar Seal

Code	Cutting Specs				Code	Cutting Specs			
	Ga.	PCS	Size	Out		Ga.	PCS	Size	Out
Cover Mat.			<u>12 3/4 X 29 5/8</u>	<u>1</u>	Lining Mat.			<u>12 3/4 X 29 5/8</u>	<u>1</u>
Cover Mat.			X		Lining Mat.			X	
Vert. Pckt.			X		Horz. Pckt.			<u>5 3/8 X 29 5/8</u>	
Vert. Pckt.			<u>12 1/8 X 16 15/16</u>	<u>1</u>	Horz. Pckt.			<u>5 3/8 X 12 7/8</u>	
Pocket			X		Pocket			X	
Label Holder			X		Card Holder	<u>EX COL</u>		<u>12 1/4 X 17 3/8</u>	
Material			X		Material	<u>COL</u>		<u>12 1/4 X 29 5/8</u>	
Material			X		Material			X	
Material			X		Material			X	
F.C. Board			<u>11 29/32 X 12 9/32</u>	<u>1</u>	B.C. Board			<u>11 29/32 X 12 9/32</u>	<u>1</u>
B.C. Board			X		B.B. Board			<u>11 29/32 X 3 21/32</u>	<u>1</u>
Center Board			X		Board			X	
Board			X		Strip			X	
Cover Pad			X		Strip			X	
					B.B. Pad			X	

Product Code

Style Case Angle D

Sheet Size

11 X 10 1/2 Cap. 1

Die No. 4078

Order No. 960306

Plate

Customer

Washington Community School

Metal
Total Vinyl
Quantity <u>100</u>
Date
Type Corners <u>RD</u>
Radius <u>1/4</u>
Completed

	Gauge	Thick
Tear Seal	<u>16</u>	<u>3/32</u>
Bar Seal	<u>128</u>	<u>3/16</u>
Bar Seal		

	No. of Feet
Tear Seal	
Bar Seal	
Bar Seal	

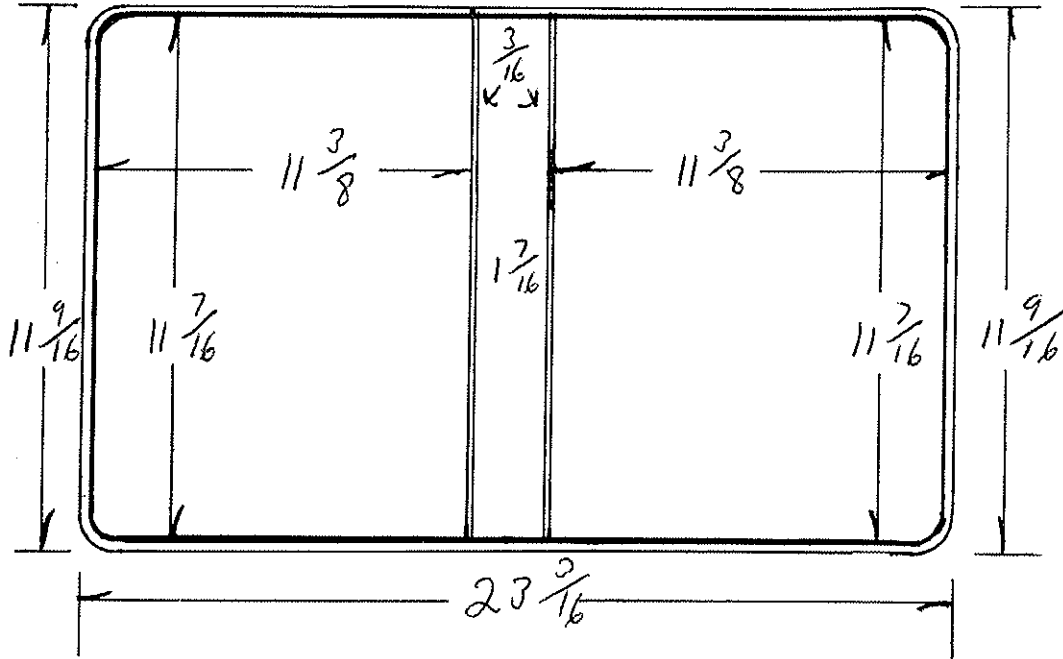

Code	Ga.	#	Cutting Specs		Code	Ga.	#	Cutting Specs	
			Size	Out				Size	Out
Cover Mat.			<u>12 3/16 X 23 13/16</u>	<u>1</u>	Lining Mat.			<u>12 3/16 X 23 13/16</u>	<u>1</u>
Cover Mat.			X		Lining Mat.			X	
Vert. Pckt.			<u>11 1/2 X 13 1/2</u>	<u>1</u>	Horz. Pckt.			<u>5 3/8 X 23 13/16</u>	
Vert. Pckt.			X		Horz. Pckt.			<u>5 3/8 X 11 7/8</u>	
Pocket			X		Pocket			X	
Label Holder			X		Card Hlder			X	
Material			X		Material			X	
Material			X		Material			X	
Material			X		Material			X	
F.C. Board			<u>11 11/32 X 11 9/32</u>	<u>1</u>	B.C. Board			<u>11 11/32 X 11 9/32</u>	<u>1</u>
B.C. Board			X		B.B. Board			<u>11 11/32 X 1 11/32</u>	<u>1</u>
Center Board			X		Board			X	
Board			X		Strip			X	
Cover Pad			X		Strip			X	
					B.B. Pad			X	

Product Code

Style Case VDRB

Sheet Size 11 X 9 Cap. 1 1/2" D' Die No. 4093

Order No. 9606840.1 Plate

Customer

Metal
Total Vinyl
Quantity
Date
Type Corners
Radius
Completed

	Gauge	Thick
Tear Seal	.016	3/32
Bar Seal	178	3/16
Bar Seal		

	No. of Feet
Tear Seal	
Bar Seal	
Bar Seal	

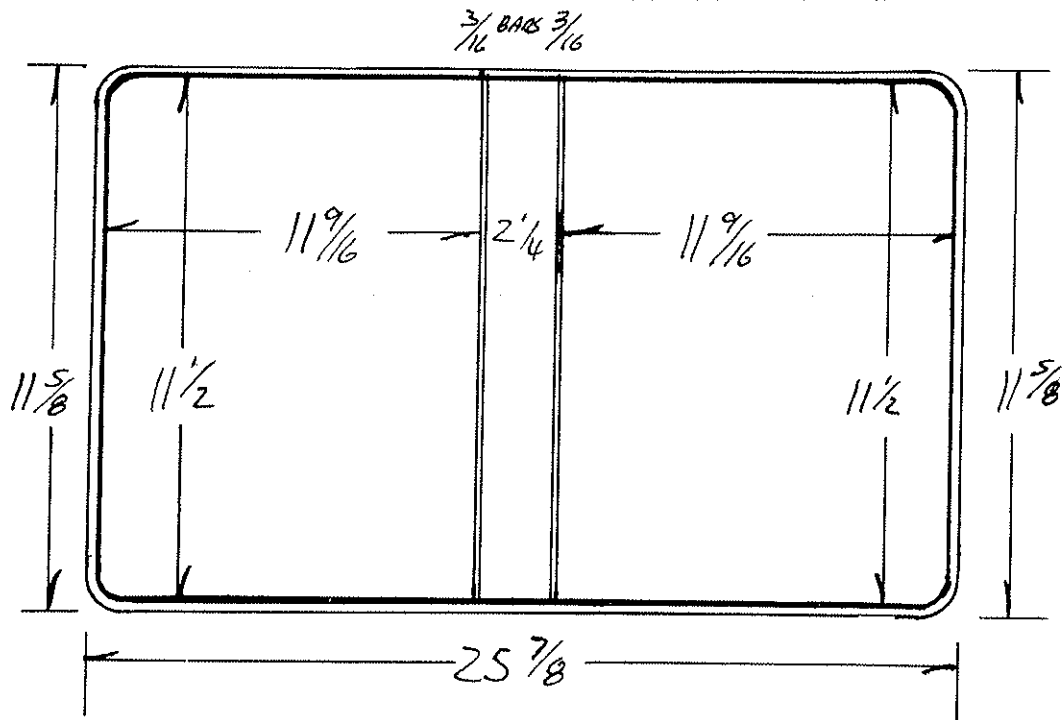

Code	Ga.	Pcs	Cutting Specs		Code	Ga.	Pcs	Cutting Specs	
			Size	Out				Size	Out
Cover Mat.			26 5/8 X 12 3/8	15 1	Lining Mat.			26 5/8 X 12 3/8	15 1
Cover Mat			X		Lining Mat.			X	
Vert. Pckt.			X		Horz. Pckt.			14 3/4 X 11 3/8	8 1
Vert. Pckt.			X		Horz. Pckt.			5 3/8 X 26 5/8	
Pocket			X		Pocket			5 3/8 X 12 1/8	
Label Holder			X		Card Holder			X	
Material			X		Material			X	
Material			X		Material			X	
Material			X		Material			X	
F.C. Board			11 13/32 X 11 15/32		B.C. Board			11 13/32 X 11 15/32	
B.C. Board			X		B.B. Board			X	
Center Board			X		Board B.B			11 13/32 X 2 5/32	
Board			X		Strip			X	
Cover Pad			X		Strip			X	
					B.B. Pad			X	

Product Code

Style Case ST, D VRB

Sheet Size 11³/₄ X 9

Cap. 1¹/₂

Die No. 4117

Order No. 961376.1

Plate

Customer VARCO - BJ.

Metal
Total Vinyl
Quantity
Date 1-9-89
Type Corners RNA
Radius 3/8
Completed

	Gauge	Thick
Tear Seal	016	3/32
Bar Seal		3/32
Bar Seal		

	No. of Feet
Tear Seal	
Bar Seal	
Bar Seal	

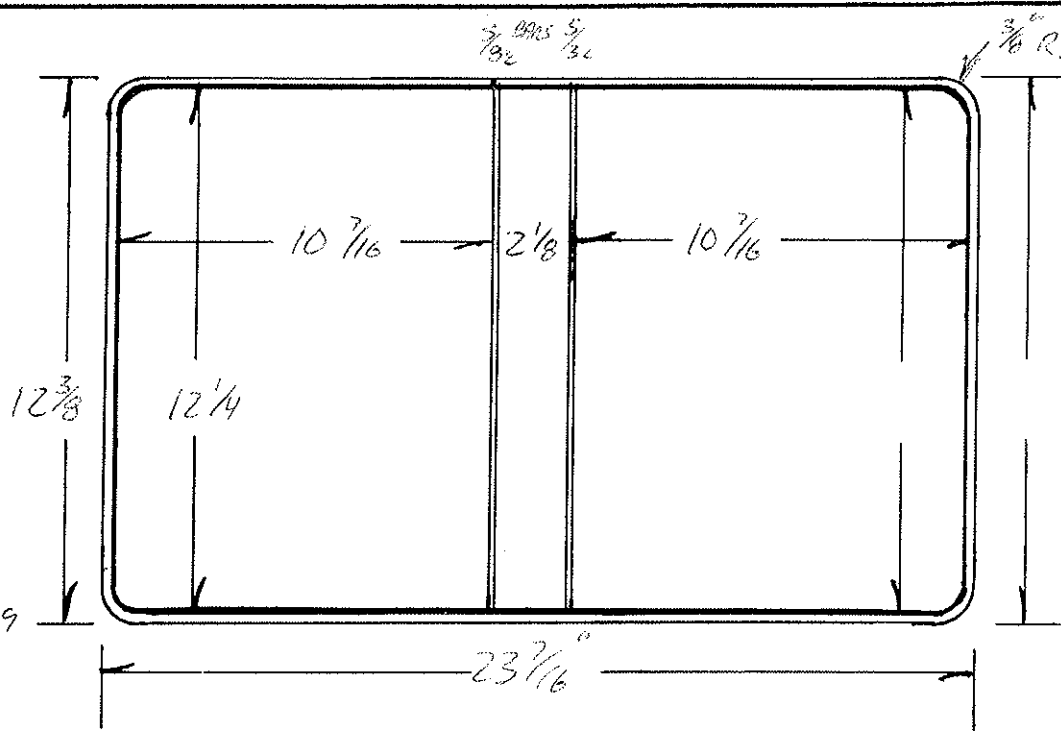

* USE PICTORIAL DIE " 4119

Code	Ga.	# PCS	Cutting Specs		Code	Ga.	# Pcs.	Cutting Specs	
			Size	Out				Size	Out
Cover Mat.		15	1		Lining Mat.		15	1	
Cover Mat.					Lining Mat.				
Vert. Pckt.					Horz. Pckt.				
Vert. Pckt.					Horz. Pckt.				
Pocket					Pocket				
Label Holder					Card Holder				
Material					Material CLEAR		8	1	
Material					Material CLEAR		8	1	
Material					Material				
F.C. Board		100	1		B.C. Board				
B.C. Board		100	1		B.B. Board				
Center Board					Board				
Board					Strip				
Cover Pad					Strip				
					B.B. Pad				

Product Code

Style Case ST, D VRB.

Sheet Size 11 3/4 X 9

Cap. 2"

Die No. 4118

Order No. 961374-1

Plate

Customer VARCO - BJ

Metal
Total Vinyl
Quantity
Date 1-9-89
Type Corners RND
Radius 3/8
Completed

	Gauge	Thick
Tear Seal	016	3/32
Bar Seal		5/32
Bar Seal		

	No. of Feet
Tear Seal	
Bar Seal	
Bar Seal	

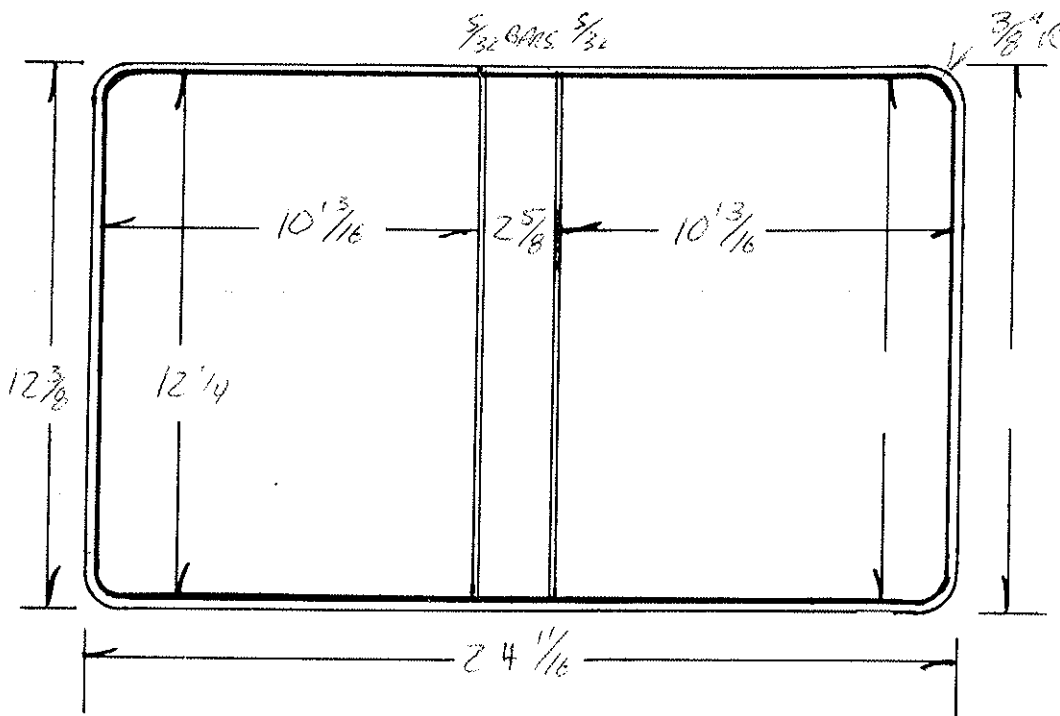

* USE METRICAL DIE # 4119

Code	Ga.	PCS	Cutting Specs		Code	Ga.	Pcs.	Cutting Specs	
			Size	Out				Size	Out
Cover Mat.			13 1/8	X 25 1/2	Lining Mat.			13 1/8	X 25 1/2
Cover Mat				X	Lining Mat.				X
Vert. Pckt.				X	Horz. Pckt.				X
Vert. Pckt.				X	Horz. Pckt.				X
Pocket				X	Pocket				X
Label Holder				X	Card Holder				X
Material				X	Material			13 1/8	X 11 1/8
Material				X	Material			13 1/8	X 3 5/8 8
Material				X	Material				X
F.C. Board			12 5/32	X 10 23/32	B.C. Board				X
B.C. Board			12 5/32	X 10 23/32	B.B. Board			12 5/32	X 2 17/32 100 1
Center Board				X	Board				X
Board				X	Strip				X
Cover Pad				X	Strip				X
					B.B. Pad				X

Product Code

Style Case A.D. VRB

Sheet Size 11 X 9 1/2 Cap. 3" A.O. Die No. 4122

Order No. 961416.1 Plate

Customer COLO PLAST

Metal	3" A.O.
Total Vinyl	
Quantity	
Date	1-13-89
Type Corners	RND
Radius	3/8" R.
Completed	

	Gauge	Thick
Tear Seal	16	3/32
Bar Seal	-	3/32
Bar Seal		

	No. of Feet
Tear Seal	
Bar Seal	
Bar Seal	

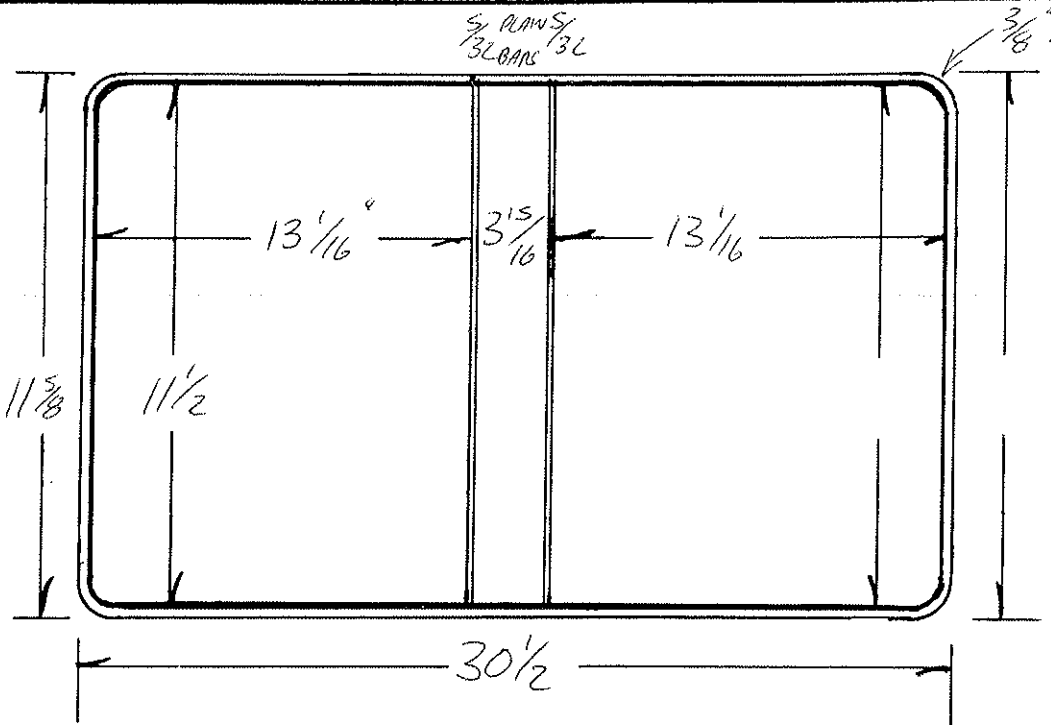

Code	Ga.	# PCS	Cutting Specs		Code	Ga.	# Pcs.	Cutting Specs	
			Size	Out				Size	Out
Cover Mat.			12 3/8	31 1/2	Lining Mat.			12 3/8	31 1/2
Cover Mat			X		Lining Mat.			X	
Vert. Pckt.			X		Horz. Pckt.			5 3/8 X	31 1/2
Vert. Pckt.			X		Horz. Pckt.			5 3/8 X	13 9/16
Pocket			X		Pocket			X	
Label Holder			X		Card Holder			X	
Material			X		Material			X	
Material			X		Material			X	
Material			X		Material			X	
F.C. Board			11 13/32	12 31/32	B.C. Board			X	
B.C. Board			11 13/32	12 31/32	B.B. Board			11 13/32	3 27/32
Center Board			11 7/16	13	Board			X	
Board			11 7/16	3 27/32	Strip			X	
Cover Pad			X		Strip			X	
					B.B. Pad			X	

Product Code

Style Case D-VRB

Sheet Size 11 X 9 Cap. 1

Die No. 4165

Order No. 962033

Plate

Customer AFQA-COMPIGRAPHICS

Metal
Total Vinyl
Quantity
Date 3-15-89
Type Corners RND
Radius 3/8
Completed

	Gauge	Thick
Tear Seal	12	3/32
Bar Seal		3/32
Bar Seal		

	No. of Feet
Tear Seal	
Bar Seal	
Bar Seal	

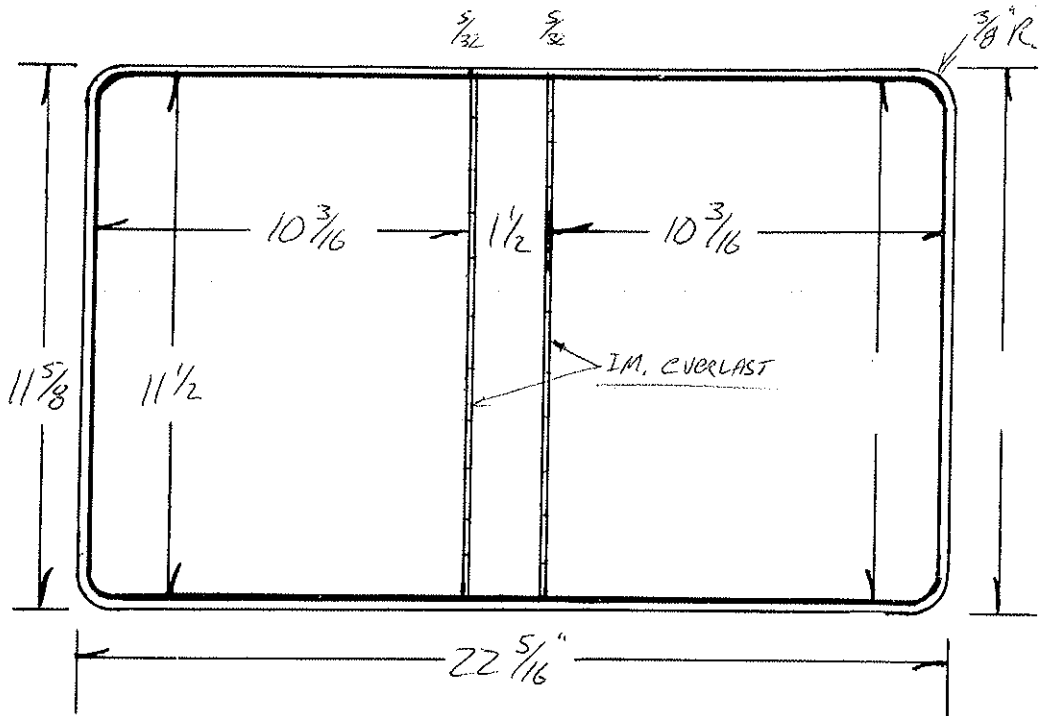

DIE CUT BD. 13 X 24

Code		Cutting Specs				Code		Cutting Specs			
		Ga.	# PCS	Size	Out			Ga.	# Pcs.	Size	Out
Cover Mat.	12 3/8 X 23 1/8	12	1			Lining Mat.	12 3/8 X 23 1/8	12	1		
Cover Mat	X					Lining Mat.	X				
Vert. Pckt.	X					Horz. Pckt.	FLAT X CUT				
Vert. Pckt.	X					Horz. Pckt.	5 3/8 X 10 1/16	12	1		
Pocket	X					Pocket	X				
Label Holder	X					Card Hlder	2 5/8 X 4 1/8	12	1		
Material	X					Material	X				
Material	X					Material	X				
Material	X					Material	X				
F.C. Board	11 1/32 X 10 3/32					B.C. Board	X				
B.C. Board	11 1/32 X 10 3/32					B.B. Board	11 1/32 X 1 1/32				
Center Board	X					Board	X				
Board	X					Strip	X				
Cover Pad	X					Strip	X				
						B.B. Pad	X				

Product Code

Style Case ST. D. VRB - Kolomou

Sheet Size 11 X 9 Cap. 1 1/2 Die No. 4319 Order No. 963952 Plate

Customer

AFGA - COMPIGRAPHICS

Metal
Total Vinyl
Quantity
Date 11-1-89
Type Corners
Radius 3/8
Completed 11-3-89 RET

	Gauge	Thick
Tear Seal	1012	1/16
Bar Seal	#254	1/32
Bar Seal		

	No. of Feet
Tear Seal	
Bar Seal	
Bar Seal	

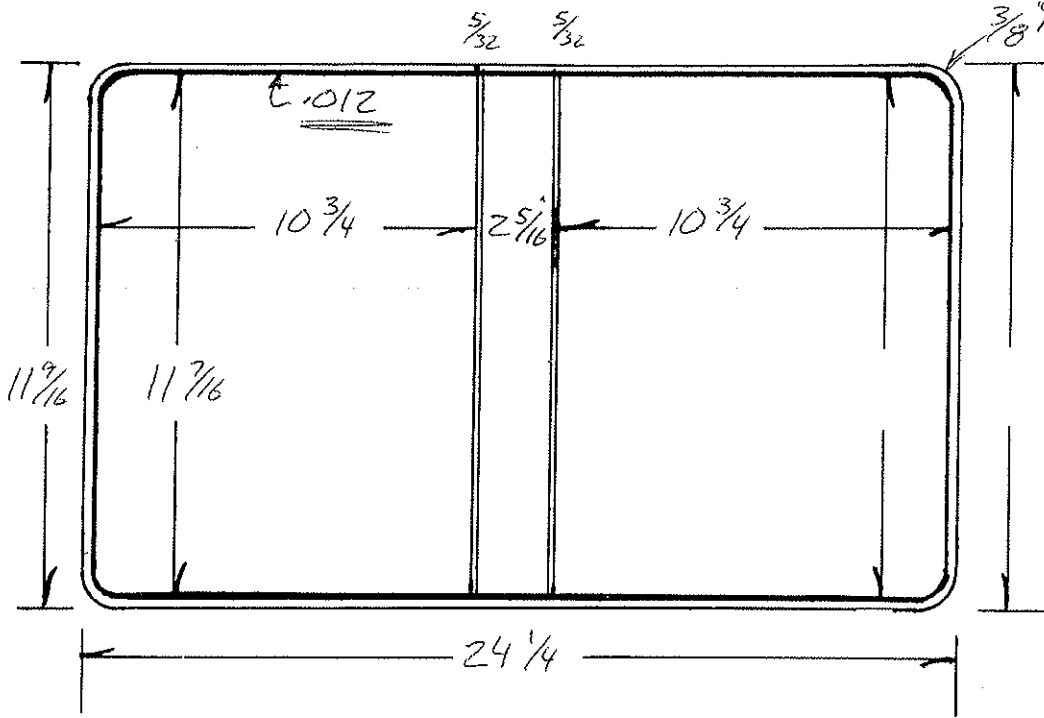

Size BY: B.P.

Check by: DM

REQUIRES CUTTING DIE #4319

Code	Ga.	PCS	Cutting Specs		Code	Ga.	Pcs.	Cutting Specs	
			Size	Out				Size	Out
Cover Mat.		12 1/4 X 25	12	1	Lining Mat.		12 1/4 X 25	12	1
Cover Mat.		X			Lining Mat.		X		
Vert. Pckt.		X			Horz. Pckt.		5 3/8 X 11 1/4	12	1
Vert. Pckt.		X			Horz. Pckt.		5 3/8 X 25		
Pocket		X			Pocket		X		
Label Holder		X			Card Hlder		X		
Material		X			Material		X		
Material		X			Material		X		
Material		X			Material		X		
F.C. Board	die	11 1/32 X 10 21/32		1	B.C. Board		X		
B.C. Board	cut	11 1/32 X 10 21/32		1	B.B. Board		11 1/32 X 2 7/32		1
Center Board		X			Board		X		
Board		X			Strip		X		
Cover Pad		X			Strip		X		
					B.B. Pad		X		

Product Code

Style Case D-VRB

Sheet Size 12 x 18 1/2 Cap. 2

Die No. 4328

Order No. 963669

Plate

Customer

COMSTOCK ENGINEERING

Metal
Total Vinyl
Quantity
Date 11-16-89
Type Corners
Radius 3/8"
Completed 11-17-89 RET

	Gauge	Thick
Tear Seal	.016	1/16
Bar Seal	#178	3/16
Bar Seal		

	No. of Feet
Tear Seal	
Bar Seal	
Bar Seal	

11-20-89

SIZES BY: B.P.

CHECK BY: *KP*

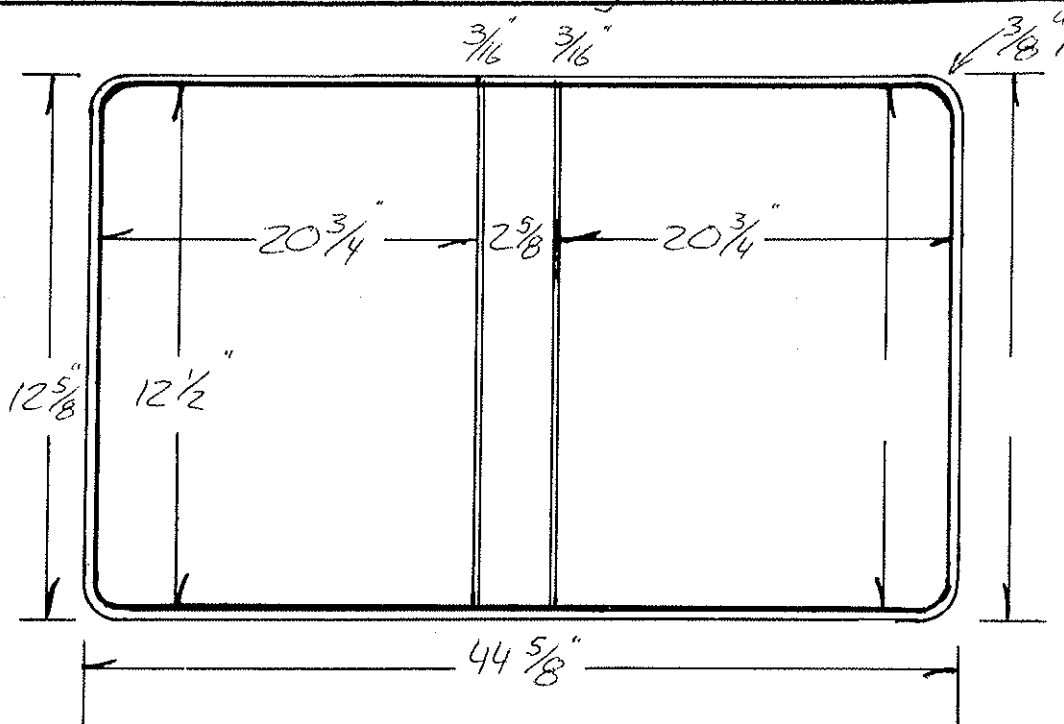

Code	Ga.	PCS	Cutting Specs		Code	Ga.	Pcs.	Cutting Specs	
			Size	Out				Size	Out
Cover Mat.		15	13 1/2 x 45 3/4	1	Lining Mat.		15	13 1/2 x 45 3/4	1
Cover Mat.			X		Lining Mat.			X	
Vert. Pckt.			X		Horz. Pckt.			X	
Vert. Rckt.			X		Horz. Pckt.			X	
Pocket			X		Pocket			X	
Label Holder			X		Card Holder			X	
Material			X		Material			X	
Material			X		Material			X	
Material			X		Material			X	
F.C. Board		100	12 13/32 x 20 21/32	1	B.C. Board			X	
B.G. Board		100	12 13/32 x 20 21/32	1	B.B. Board		100	12 13/32 x 2 17/32	1
Center Board			X		Board			X	
Board			X		Strip			X	
Cover Pad			X		Strip			X	
					B.B. Pad			X	

Product Code

Style Case A.D. VRB

Sheet Size 11 X 9

Cap. 3-A.D Die No. 4366

Order No. 964545 Plate

Customer

STUDIOGRAPHIX

Metal
Total Vinyl
Quantity
Date <u>1-24-90</u>
Type Corners
Radius
Completed

	Gauge	Thick
Tear Seal	<u>.012</u>	<u>1/16"</u>
Bar Seal		
Bar Seal		

	No. of Feet
Tear Seal	
Bar Seal	
Bar Seal	

Size - B.P.
Check - [Signature]

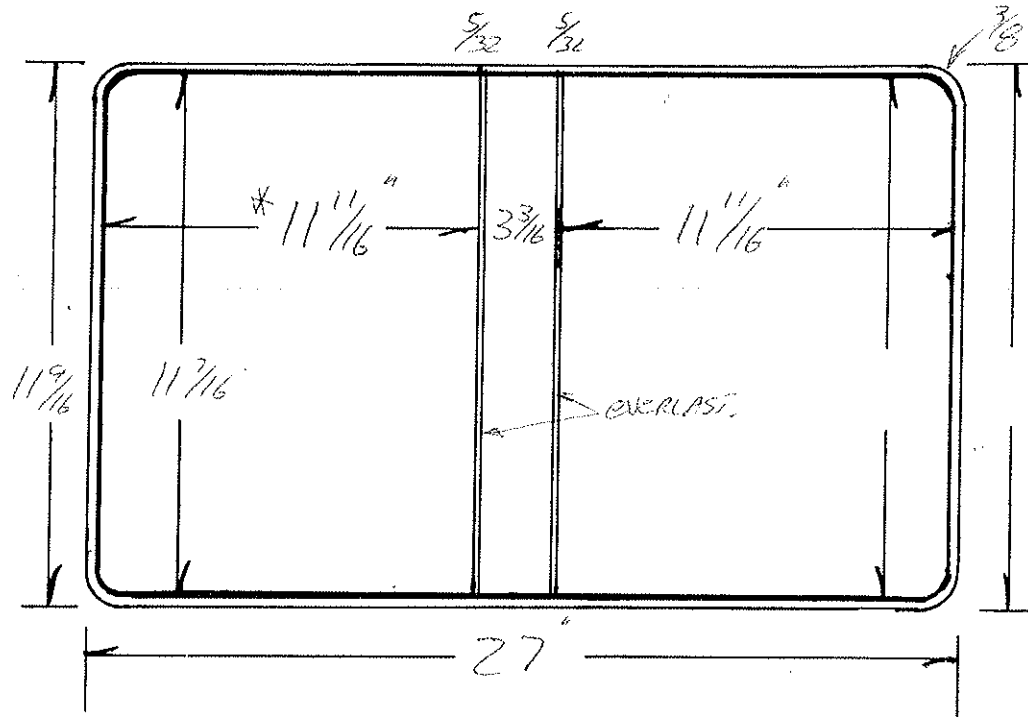

* PER SAMPLE
 CUSTOMER REQUIRES VRB TO BE
 SAME AS SAMPLE

Code	Ga.	# PCS	Cutting Specs		Code	Ga.	# Pcs.	Cutting Specs	
			Size	Out				Size	Out
Cover Mat.		<u>12 1/4 X 28</u>	<u>12</u>	<u>1</u>	Lining Mat.		<u>12 1/4 X 28</u>	<u>12</u>	<u>1</u>
Cover Mat.		X			Lining Mat.		X		
Vert. Pckt.		X			Horz. Pckt.		<u>5 3/8 X 12 3/16</u>		
Vert. Pckt.		X			Horz. Pckt.		<u>5 3/8 X 28</u>		
Pocket		X			Pocket		X		
Label Holder		X			Card Holder		X		
Material		X			Material		X		
Material		X			Material		X		
Material		X			Material		X		
F.C. Board		<u>11 1/32 X 11 19/32</u>		<u>1</u>	B.C. Board		X		
B.C. Board		<u>11 1/32 X 11 19/32</u>		<u>1</u>	B.B. Board		<u>11 1/32 X 3 3/32</u>		<u>1</u>
Center Board		X			Board		X		
Board		X			Strip		X		
Cover Pad		X			Strip		X		
					B.B. Pad		X		

Product Code

Style Case D-VRB

Sheet Size 11 X 9

Cap. 1 1/2-D Die No. 4376

Order No. 964681

Plate

Customer

SCHREIBER CORP.

Metal
Total Vinyl
Quantity
Date
Type Corners
Radius <u>3/16"</u>
Completed

	Gauge	Thick
Tear Seal	<u>.014</u>	<u>1/16</u>
Bar Seal	<u>#253</u>	<u>5/32</u>
Bar Seal		

	No. of Feet
Tear Seal	
Bar Seal	
Bar Seal	

SIZE - B.P.A.C.
CHECK -
14

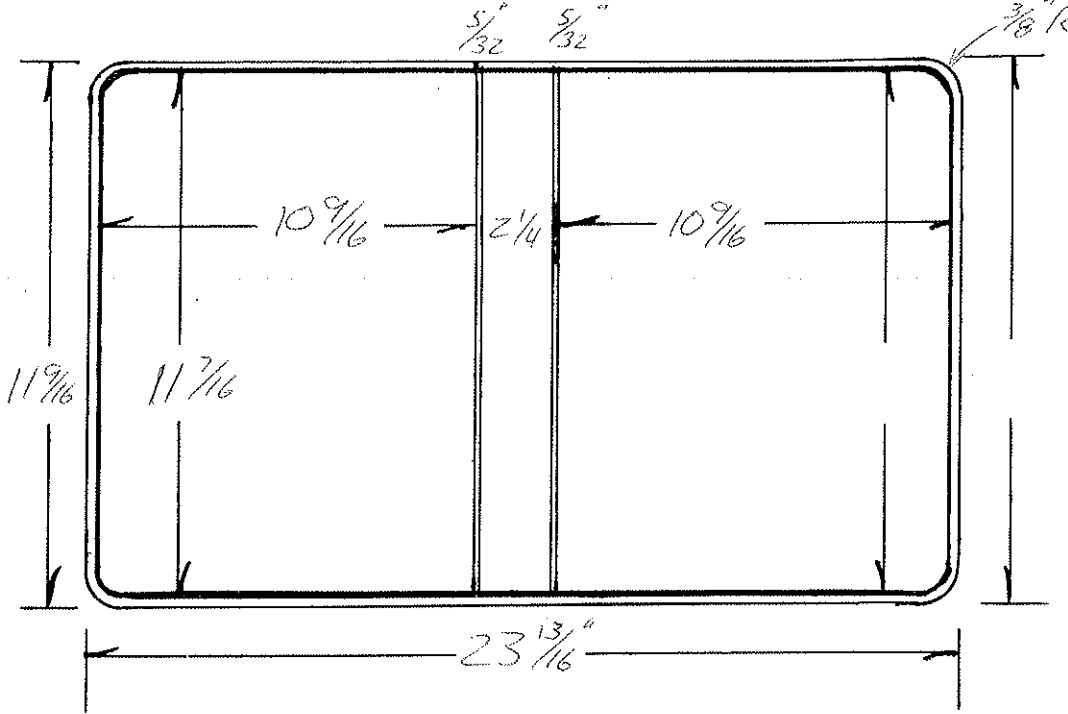

Code		Cutting Specs		Code		Cutting Specs			
		Ga.	# PCS	Size	Out	Ga.	Pcs.	Size	Out
Cover Mat.	<u>12 1/4 X 24 5/8</u>	<u>15</u>	<u>1</u>			Lining Mat.	<u>12 1/4 X 24 5/8</u>	<u>15</u>	<u>1</u>
Cover Mat.	X					Lining Mat.	X		
Vert. Pckt.	X					Horz. Pckt.	<u>5 3/8 X 11 1/16</u>		
Vert. Pckt.	X					Horz. Pckt.	<u>5 3/8 X 24 5/8</u>		
Pocket	X					Pocket	X		
Label Holder	X					Card Hlder	<u>2 3/8 X 3 1/8</u>	<u>0</u>	<u>1</u>
Material	X					Material	X		
Material	X					Material	X		
Material	X					Material	X		
F.C. Board	<u>11 1/32 X 10 15/32</u>	<u>100</u>	<u>1</u>			B.C. Board	X		
B.C. Board	<u>11 1/32 X 10 15/32</u>	<u>100</u>	<u>1</u>			B.B. Board	<u>11 1/32 X 2 9/32</u>	<u>100</u>	<u>1</u>
Center Board	X					Board	X		
Board	X					Strip	X		
Cover Pad	X					Strip	X		
						B.B. Pad	X		

Product Code

Style Case *STR D VRB*

Sheet Size *11 X 9*

Cap. *2*

Die No. *4415*

Order No. *965377*

Plate

Customer

COMMONWEALTH PUBLISHING

Metal
Total Vinyl
Quantity <i>100</i>
Date <i>4-27-90</i>
Type Corners
Radius
Completed

	Gauge	Thick
Tear Seal	<i>2014</i>	<i>1/16</i>
Bar Seal	<i>2170</i>	<i>3/16</i>
Bar Seal		

	No. of Feet
Tear Seal	
Bar Seal	
Bar Seal	

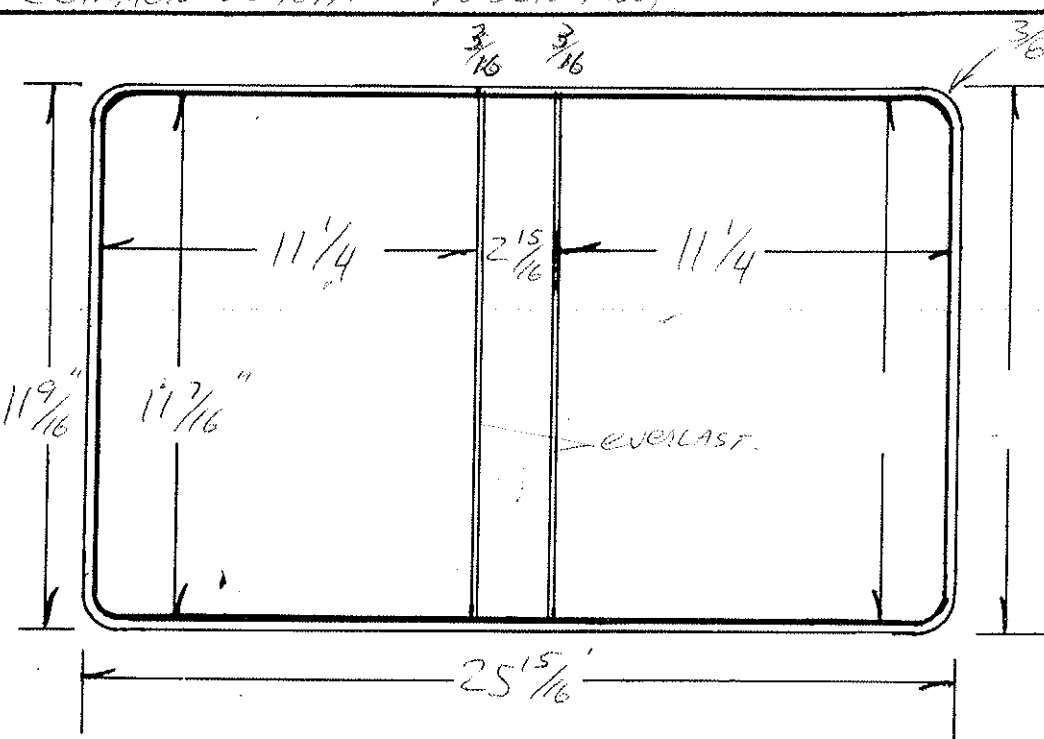

Drawn BP
Check by KP

Code	Ga.	Pcs	Cutting Specs		Code	Ga.	Pcs	Cutting Specs	
			Size	Out				Size	Out
Cover Mat.			$12 \frac{1}{4}$	$26 \frac{3}{4}$	Lining Mat.			$12 \frac{1}{4}$	$26 \frac{3}{4}$
Cover Mat.			X		Lining Mat.			X	
Vert. Pckt.			X		Horz. Pckt.			$5 \frac{3}{8}$	$11 \frac{3}{4}$
Vert. Pckt.			X		Horz. Pckt.			$5 \frac{3}{8}$	$26 \frac{3}{4}$
Pocket			X		Pocket			X	
Label Holder			X		Card Hlder			X	
Material			X		Material			X	
Material			X		Material			X	
Material			X		Material			X	
F.C. Board			$11 \frac{1}{32}$	$11 \frac{5}{32}$	B.C. Board			X	
B.C. Board			$11 \frac{1}{32}$	$11 \frac{5}{32}$	B.B. Board			$11 \frac{1}{32}$	$22 \frac{1}{32}$
Center Board			X		Board			X	
Board			X		Strip			X	
Cover Pad			X		Strip			X	
					B.B. Pad			X	

Product Code

Style Case VRB - D RING

Sheet Size 11 X 9

Cap. Z-D Die No. 4521

Order No. 965597

Plate

Customer

Hume Publishing

(1 up)

Metal
Total Vinyl
Quantity
Date
Type Corners
Radius
Completed

.014 REVERSED RULE $\frac{1}{8}$ $\frac{1}{8}$ - HFT Rule EVERLAST $\frac{3}{8}$ " R

	Gauge	Thick
Tear Seal		
Bar Seal	<u>HFT 72</u>	$\frac{1}{8}$ "
Bar Seal	<u>.014</u>	$\frac{1}{16}$ "
	No. of Feet	
Tear Seal		
Bar Seal		
Bar Seal		

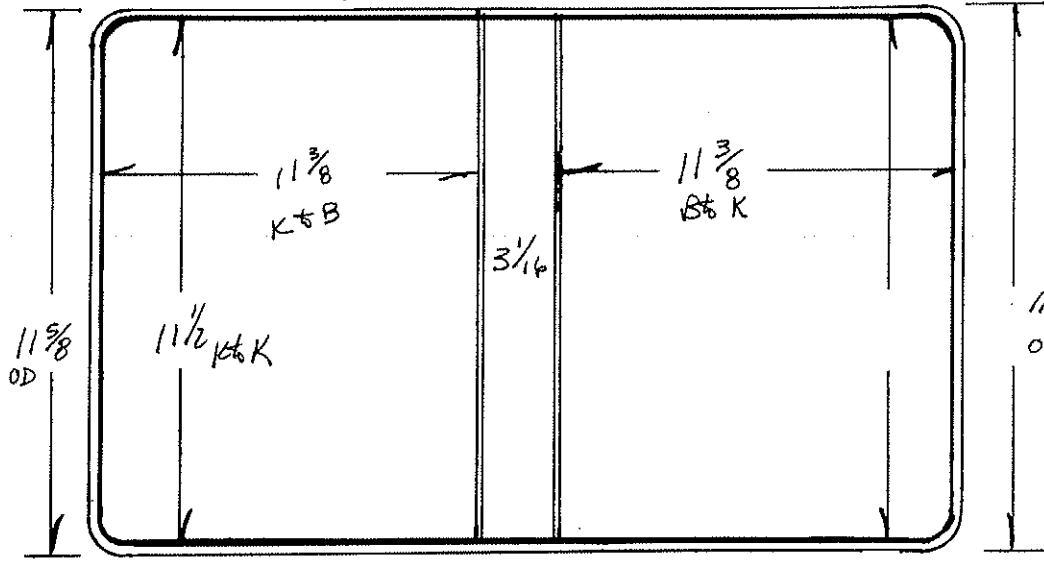

4443 Z-up FIAB

Code	Cutting Specs				Code	Cutting Specs			
	Ga.	PCS	Size	Out		Ga.	Pcs.	Size	Out
Cover Mat.		X			Lining Mat.		12 1/4 X 27		1
Cover Mat.		12 1/4 X 27		1	Lining Mat.		X		
Vert. Pckt.		X			Horz. Pckt.		5 3/8 X 11 7/8		
Vert. Pckt.		12 1/4 X 5 1/4		1	Horz. Pckt.		5 3/8 X 27		
Pocket		X			Pocket		X		
Label Holder		X			Card Holder		X		
Material		X			Material		X		
Material		X			Material		X		
Material		X			Material		X		
F.C. Board		11 3/8 X 11 1/4	120	1	B.C. Board		X		
B.C. Board		11 3/8 X 11 1/4	120	1	B.B. Board		11 3/8 X 2 3/32	120	1
Center Board		X			Board		X		
Board		X			Strip		X		
Cover Pad		X			Strip		X		
					B.B. Pad		X		

Product Code

Style Case URB D Ring

Sheet Size 11 X 9

Cap. 3/4

Die No. 4664

Order No.

Plate C-11-3

Customer

I.B.M.

PART NO. 1SF1932

Metal
Total Vinyl
Quantity
Date <u>7-18-91</u>
Type Corners
Radius
Completed

	Gauge	Thick
Tear Seal	<u>.014</u>	<u>1/16</u>
Bar Seal	<u>#253</u>	<u>1/8</u>
Bar Seal		

	No. of Feet
Tear Seal	
Bar Seal	
Bar Seal	

SIZE - B.PACK

CHECK

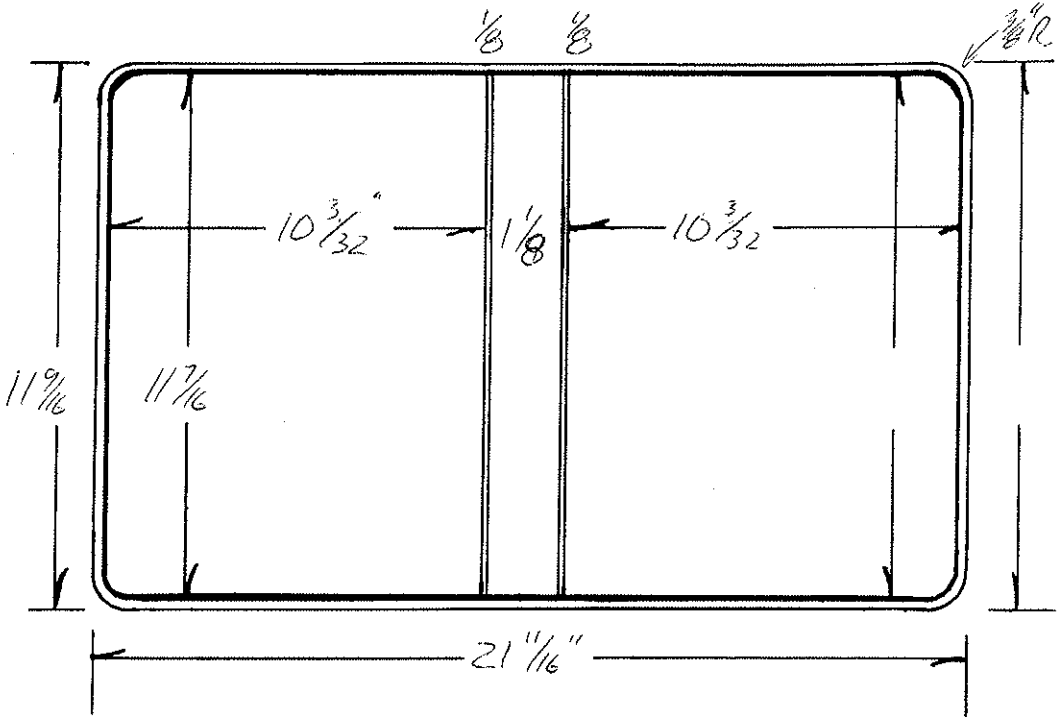

Code	Cutting Specs				Code	Cutting Specs			
	Ga.	#	Size	Out		Ga.	#	Size	Out
Cover Mat.			<u>12 1/4 X 22 1/2</u>	<u>1</u>	Lining Mat.			<u>12 1/4 X 22 1/2</u>	<u>1</u>
Cover Mat			<u>X</u>		Lining Mat.			<u>X</u>	
Vert. Pckt.			<u>X</u>		Horz. Pckt.			<u>5 3/8 X 10 5/8</u>	
Vert. Pckt.			<u>X</u>		Horz. Pckt.			<u>5 3/8 X 22 1/2</u>	
Pocket			<u>X</u>		Pocket			<u>X</u>	
Label Holder			<u>X</u>		Card Holder			<u>X</u>	
Material			<u>X</u>		Material			<u>X</u>	
Material			<u>X</u>		Material			<u>X</u>	
Material			<u>X</u>		Material			<u>X</u>	
F.C. Board			<u>11 3/8 X 10 1/32</u>	<u>1</u>	B.C. Board			<u>X</u>	
B.C. Board			<u>11 3/8 X 10 1/32</u>	<u>1</u>	B.B. Board			<u>11 3/8 X 1 1/32</u>	<u>1</u>
Center Board			<u>X</u>		Board			<u>X</u>	
Board			<u>X</u>		Strip			<u>X</u>	
Cover Pad			<u>X</u>		Strip			<u>X</u>	
					B.B. Pad			<u>X</u>	

Product Code

Style Case *VRB*

D Ring

Sheet Size *11 X 9*

Cap. *1 1/4*

Die No. *4665*

Order No. -

Plate

Customer

J.B.M.

PART NO. 15F1505

Metal
Total Vinyl
Quantity <i>2-10-91</i>
Date
Type Corners
Radius
Completed

	Gauge	Thick
Tear Seal	<i>014</i>	<i>1/16</i>
Bar Seal	<i>#253</i>	<i>1/8</i>
Bar Seal		

	No. of Feet
Tear Seal	
Bar Seal	
Bar Seal	

SIZE - Brace
CHECK -

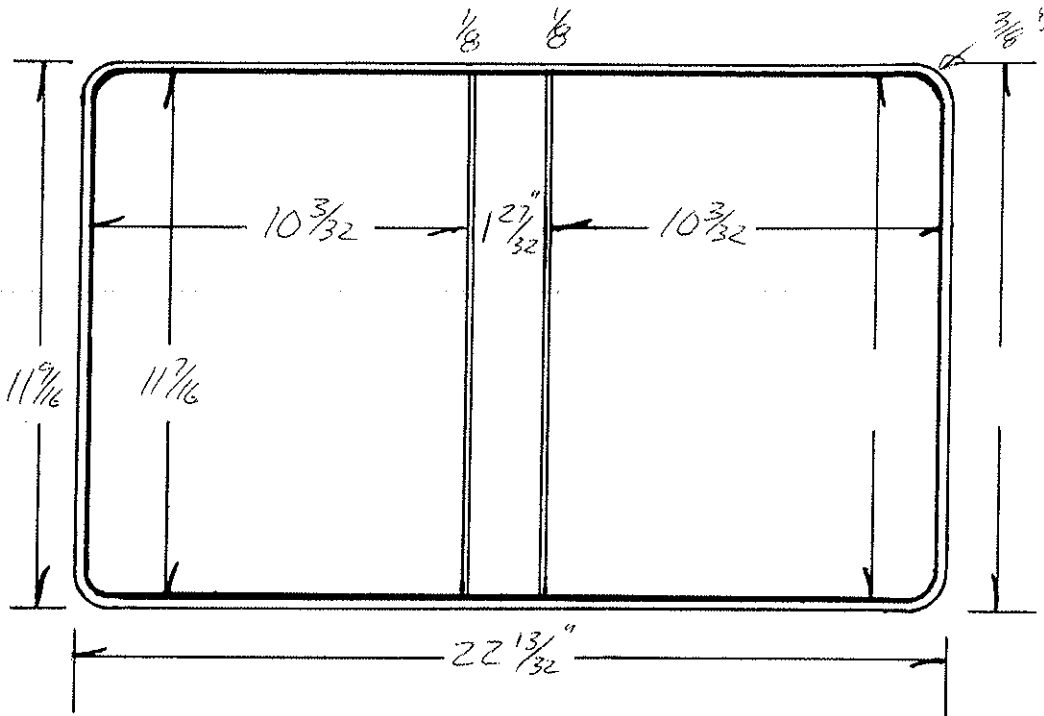

Code	Ga.	PCS	Cutting Specs		Code	Ga.	Pcs.	Cutting Specs	
			Size	Out				Size	Out
Cover Mat.			<i>12 1/4</i>	<i>X 23 1/4</i>	Lining Mat.			<i>12 1/4</i>	<i>X 23 1/4</i>
Cover Mat				<i>X</i>	Lining Mat.				<i>X</i>
Vert. Pckt.				<i>X</i>	Horz. Pckt.			<i>5 3/8</i>	<i>X 10 5/8</i>
Vert. Pckt.				<i>X</i>	Horz. Pckt.			<i>5 3/8</i>	<i>X 23 1/4</i>
Pocket				<i>X</i>	Pocket				<i>X</i>
Label Holder				<i>X</i>	Card Holder				<i>X</i>
Material				<i>X</i>	Material				<i>X</i>
Material				<i>X</i>	Material				<i>X</i>
Material				<i>X</i>	Material				<i>X</i>
F.C. Board			<i>11 3/8</i>	<i>X 10 1/32</i>	B.C. Board				<i>X</i>
B.C. Board			<i>11 3/8</i>	<i>X 10 1/32</i>	B.B. Board			<i>11 3/8</i>	<i>X 1 3/4</i>
Center Board				<i>X</i>	Board				<i>X</i>
Board				<i>X</i>	Strip				<i>X</i>
Cover Pad				<i>X</i>	Strip				<i>X</i>
					B.B. Pad				<i>X</i>

Product Code

Style Case VRB KOLOMAN STR-65/303

Sheet Size 11³/₄ x 8³/₄ Cap. 2¹/₂

Die No. 4683

Order No. 967784

Plate C-12-4

Customer FLUOR DANIEL

Customer	
Metal	
Total Vinyl	
Quantity	<u>38</u>
Date	<u>3-11-91</u>
Type Corners	
Radius	<u>3/8</u>
Completed	

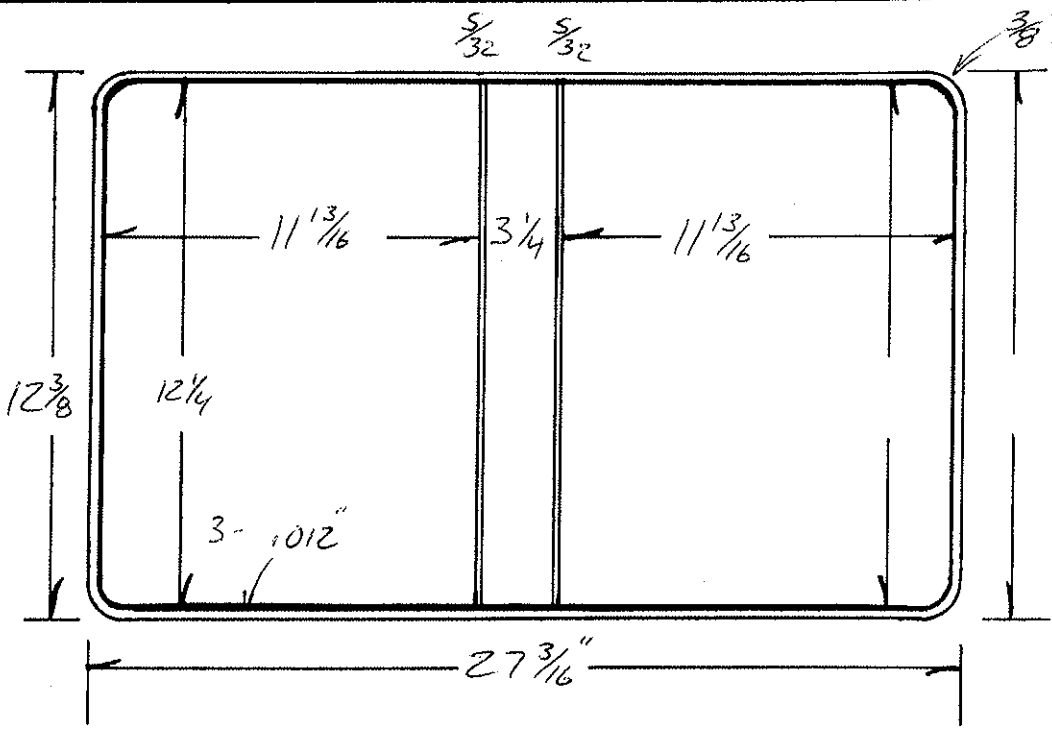

	Gauge	Thick
Tear Seal	<u>.012</u>	<u>1/16</u>
Bar Seal	<u>#254</u>	<u>5/32</u>
Bar Seal		

	No. of Feet
Tear Seal	
Bar Seal	
Bar Seal	

SIZE - BRACE
CHECK - RPV

Code	Ga.	Pcs	Cutting Specs		Code	Ga.	Pcs	Cutting Specs	
			Size	Out				Size	Out
Cover Mat.			13 1/8	28"	Lining Mat.			13 1/8	28"
Cover Mat			X		Lining Mat.			X	
Vert. Pckt.			X		Horz. Pckt.			X	
Vert. Pckt.			X		Horz. Pckt.			X	
Pocket			X		Pocket			X	
Label Holder			X		Card Holder			X	
Material			X		Material			X	
Material			X		Material			X	
Material			X		Material			X	
F.C. Board			12 5/32	11 23/32	B.C. Board			X	
B.C. Board			12 5/32	11 23/32	B.B. Board			12 5/32	3 5/32
Center Board			X		Board			X	
Board			X		Strip			X	
Cover Pad			X		Strip			X	
					B.B. Pad			X	

1" VKB w/12" Panel

Product Code

Style Case VRB - ABLE DIE CO

Sheet Size 11 X 9^{1/2} Cap. 1" AD Die No. 4754 Order No. 968235 Plate

Customer

COMMUNICATIONS MARKETING DISTRIBUTORS

Metal
Total Vinyl
Quantity 30,000
Date 5-10-91
Type Corners
Radius
Completed

	Gauge	Thick
Tear Seal	.012	1/8
Bar Seal		
Bar Seal		

	No. of Feet
Tear Seal	
Bar Seal	
Bar Seal	

SEE DWG.

Dwg - B. Pace
CHECK - 

MADE BY: ABLE DIE CO.

Code	Ga.	CS	Cutting Specs		Code	Ga.	Pcs.	Cutting Specs				
			Size	Qty.				Size	Qty.			
Cover Mat.			12 7/8 X 24 3/4	14	1			12 7/8 X 24 3/4	14	1		
Cover Mat			X					Lin g Mat.		X		
Vert. Pckt.			X					Hor. Pckt.		5 3/8 X 11 5/8		
Vert. Pckt.			X					Horz. Pckt.		5 3/8 X 24 3/4		
Pocket			X					Pocket		X		
Label Holder			X					Card Holder		X		
Material			X					Material		X		
Material			X					Material		X		
Material			X					Material		X		
F.C. Board	1" strip		11 7/16 X 11	100	1			B.C. Board		X		
B.C. Board	1" strip		11 7/16 X 11	100	1			B.B. Board	1" strip	11 7/16 X 1 1/32	100	1
Center Board			X					Board		X		
Board			X					Strip		X		
Cover Pad			X					Strip		X		
								B.B. Pad		X		

Product Code

Style Case 2 ADV. AD VRA

Sheet Size $11\frac{1}{4} \times 9\frac{5}{8}$ Cap. 2 AD. Die No. 4868

Order No. 969896

Plate C-18

Customer

ALABAMA GAS CORP.

9-13

Metal
Total Vinyl
Quantity 50
Date 9-3-91
Type Corners
Radius
Completed

	Gauge	Thick
Tear Seal	.014	1/16
Bar Seal	48-4	5/16
Bar Seal		

	No. of Feet
Tear Seal	
Bar Seal	
Bar Seal	

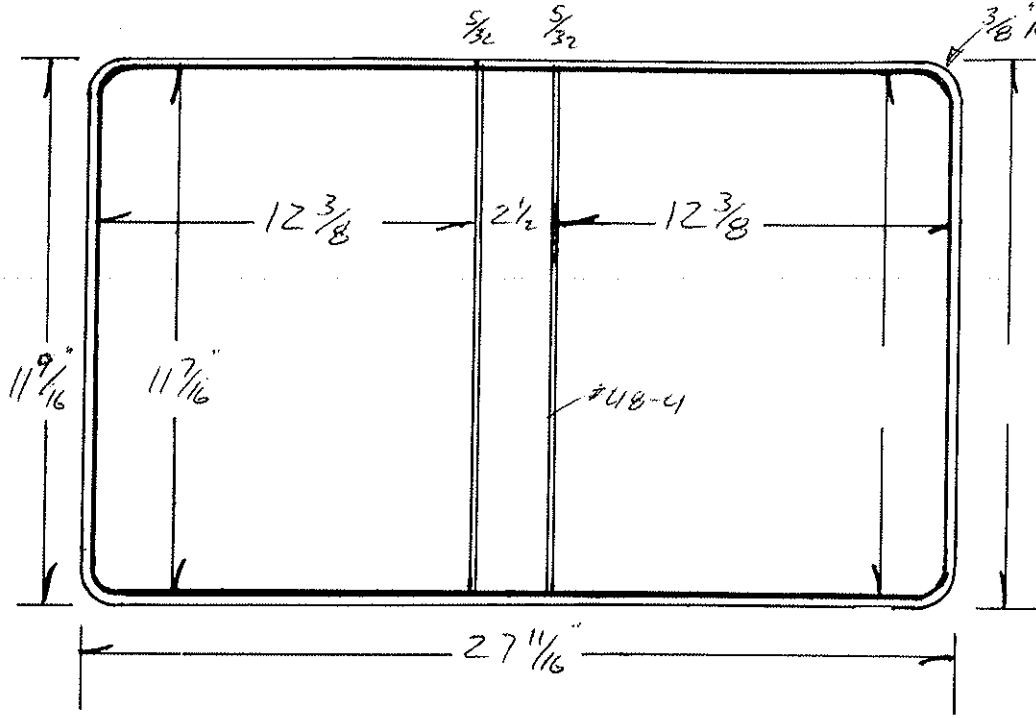

Dwg - B. Pace
 Check. *(Signature)*

Code		Cutting Specs		Code		Cutting Specs			
		Ga.	PCS	Size	Out	Ga.	Pcs.	Size	C
Cover Mat.	$12\frac{1}{4} \times 28\frac{1}{2}$		1			Lining Mat.		$12\frac{1}{4} \times 28\frac{1}{2}$	1
Cover Mat	X					Lining Mat.		X	
Vert. Pckt.	X					Horz. Pckt. FC		$5\frac{3}{8} \times 12\frac{7}{8}$	1
Vert. Pckt.	X					Horz. Pckt.		X	
Pocket	X					Pocket		X	
Label Holder	X					Card Holder		X	
Material	X					Material		X	
Material	X					Material		X	
Material	X					Material		X	
F.C. Board	$11\frac{1}{32} \times 12\frac{9}{32}$	120	1			B.C. Board		X	
B.C. Board	$11\frac{1}{32} \times 12\frac{9}{32}$	120	1			B.B. Board		$11\frac{1}{32} \times 2\frac{13}{32}$	120 1
Center Board	X					Board		X	
Board	X					Strip		X	
Cover Pad	X					Strip		X	
						B.B. Pad		X	

Product Code

Style Case *URB 11-3-Z-D HULLMAN*

Sheet Size *11 x 9*

Cap. *2" D*

Die No. *4943*

Order No. *970902*

Plate *D-2-6*

Customer

RR DONNELLEY & SONS CO.

1-9-92

Metal
Total Vinyl
Quantity
Date <i>12-20-91</i>
Type Corners
Radius
Completed

	Gauge	Thick
Tear Seal	<i>.014</i>	<i>1/16</i>
Bar Seal	<i>48-4</i>	<i>5/32"</i>
Bar Seal		

	No. of Feet
Tear Seal	
Bar Seal	
Bar Seal	

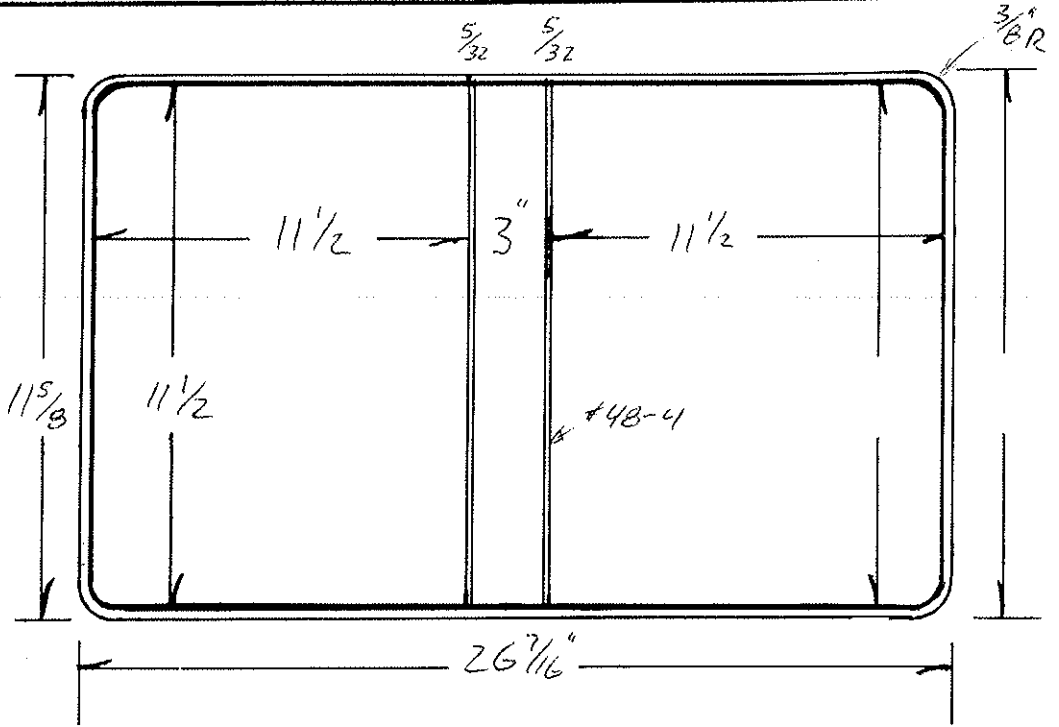

Dwg - B. PAIC
CHECK
(Signature)

PER SAMPLE

Code	Ga.	# PCS	Cutting Specs		Code	Ga.	# Pcs.	Cutting Specs	
			Size	Out				Size	Out
Cover Mat.		<i>12 1/4 X 27 1/4</i>		<i>1</i>	Lining Mat.		<i>12 1/4 X 27 1/4</i>		<i>1</i>
Cover Mat.		X			Lining Mat.		X		
Vert. Pckt.		X			Horz. Pckt.		X		
Vert. Rckt.		X			Horz. Pckt.		X		
Pocket		X			Pocket		X		
Label Holder		X			Card Hlder		X		
Material	<i>C.O.L.</i>	<i>11 13/16 X 27 1/4</i>	<i>8</i>	<i>1</i>	Material		X		
Material		X			Material		X		
Material		X			Material		X		
F.C. Board		<i>11 13/32 X 11 13/32</i>	<i>120</i>	<i>1</i>	B.C. Board		X		
B.C. Board		<i>11 13/32 X 11 13/32</i>	<i>100</i>	<i>1</i>	B.B. Board		<i>11 13/32 X 2 29/32</i>	<i>120</i>	
B.A.C.U.P. Board		<i>11 3/8 X 11 3/8</i>	<i>22</i>	<i>1</i>	Board		X		
Board		X			Strip		X		
Cover Pad		X			Strip		X		
					B.B. Pad		X		

Product Code

Style Case STR 0 VRB 3-D L.L.

Sheet Size 11 X 9

Cap. 3-D

Die No. 4958

Order No. 971018

Plate 0-3-5

Customer

R R DONNELLEY & SONS CO.

1-17

Metal	L.L. 4-3-3-17
Total Vinyl	
Quantity	1760
Date	1-2-92
Type Corners	
Radius	3/16
Completed	

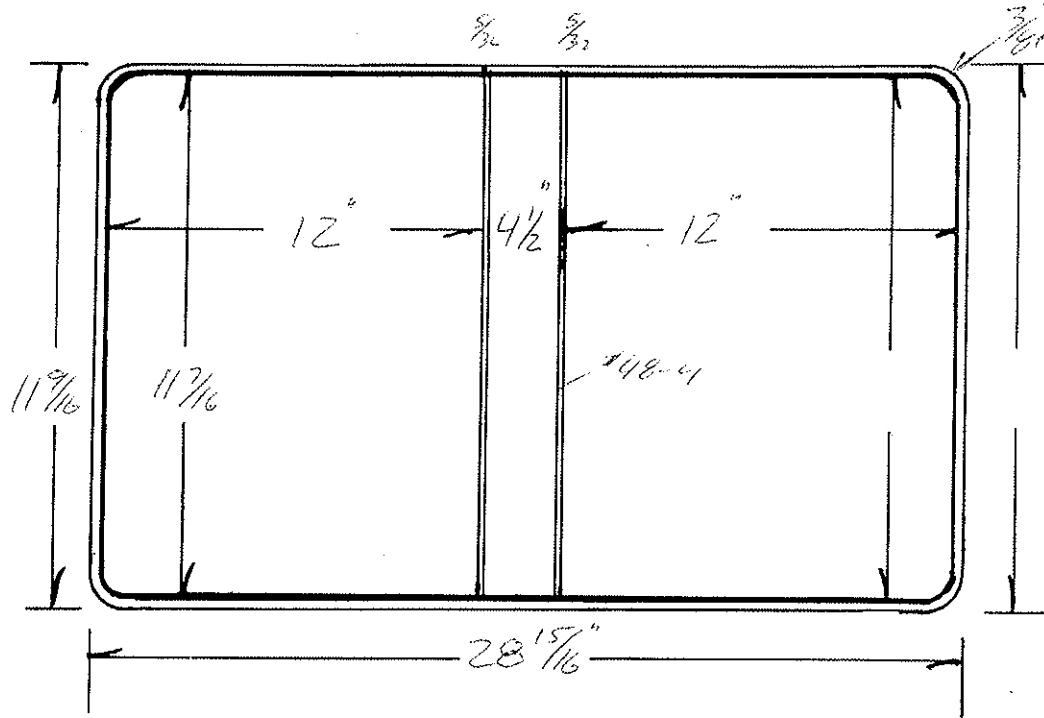

	Gauge	Thick
Tear Seal	.014	1/16
Bar Seal	48-4	3/16
Bar Seal		

	No. of Feet
Tear Seal	
Bar Seal	
Bar Seal	

Dwg. B Spec
 CHECK. *(Signature)*

Code	Ga.	# PCS	Cutting Specs		Code	Ga.	# Pcs.	Cutting Specs	
			Size	Out				Size	Out
Cover Mat.		14	12 1/4 X 29 3/4	1	Lining Mat.		14	12 1/4 X 29 3/4	1
Cover Mat			X		Lining Mat.			X	
Vert. Pckt.			X		Horz. Pckt.			X	
Vert. Pckt.			X		Horz. Pckt.			X	
Pocket			X		Pocket			X	
Label Holder	FULL		X		Card Holder			X	
Material	COL.	8	11 11/16 X 29 3/4	1	Material			X	
Material			X		Material			X	
Material			X		Material			X	
F.C. Board		120	11 1/32 X 11 29/32	1	B.C. Board	BACK-UP	22	11 5/16 X 11 7/8	1
B.C. Board		10	11 1/32 X 11 29/32	1	B.B. Board		120	11 1/32 X 4 11/32	1
Center Board			X		Board			X	
Board			X		Strip			X	
Cover Pad			X		Strip			X	
					B.B. Pad			X	

Product Code

Style Case *VRB*

Sheet Size *11 X 9*

Cap. *1 1/2 A.D*

Die No. *4997-B*

Order No. *971463*

Plate *0-4-0*

Customer

R. R. Donnelley

2-28

Metal
Total Vinyl
Quantity <i>3 -</i>
Date <i>2-25-92</i>
Type Corners
Radius <i>3/8</i>
Completed

	Gauge	Thick
Tear Seal	<i>.014</i>	<i>1/16</i>
Bar Seal	<i>48-3</i>	<i>1/8</i>
Bar Seal		

	No. of Feet
Tear Seal	
Bar Seal	
Bar Seal	

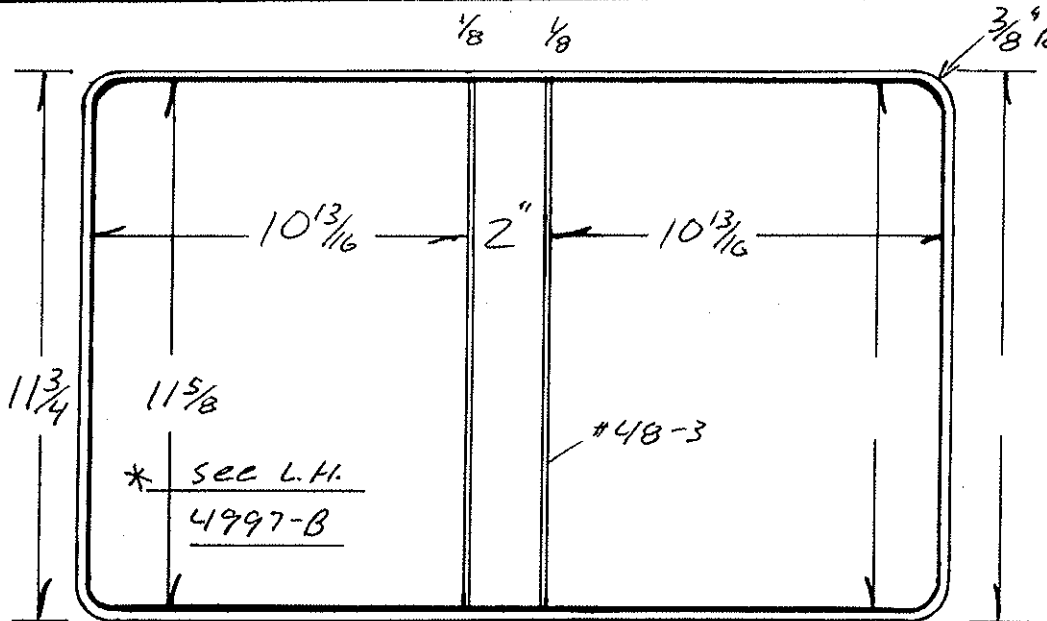

Dwg - B. Page
Check - VRB

** LAYOUT ART FOR 1/4" TEAR-OVER*

** PER SAMPLE*

		Cutting Specs						Cutting Specs			
Code		Ga.	PCS	Size	Out	Code		Ga.	PCS	Size	Out
Cover Mat.	$12\frac{1}{4} \times 24\frac{3}{4}$	14	1			Lining Mat.	$12\frac{1}{4} \times 24\frac{3}{4}$	14	1		
Cover Mat	X					Lining Mat.	X				
Vert. Pckt.	X					Horz. Pckt.	$5\frac{3}{8} \times 11\frac{5}{16}$				
Vert. Pckt.	X					Horz. Pckt.	X				
Pocket	X					Pocket	X				
Label Holder	<i>4997-B</i> $5\frac{3}{8} \times 1\frac{3}{8}$	8	1			Card Holder	X				
Material	X					Material	X				
Material	X					Material	X				
Material	X					Material	X				
F.C. Board	$11\frac{17}{32} \times 10\frac{23}{32}$	120	1			B.C. Board	X				
B.C. Board	$11\frac{17}{32} \times 10\frac{23}{32}$	120	1			B.B. Board	$11\frac{17}{32} \times 1\frac{29}{32}$	120	1		
Center Board	X					Board	X				
Board	X					Strip	X				
Cover Pad	X					Strip	X				
						B.B. Pad	X				

Product Code

Style Case

Angle D

Sheet Size 11 x 10 Cap. 1 1/2 Die No. 5/42

Order No. 973075.1 Plate 8-14

Customer

Shiseido Cosmetics

D10-4

Metal
Total Vinyl
Quantity 275
Date 8-10-92
Type Corners
Radius 3/8
Completed

	Gauge	Thick
Tear Seal	20/32	1/32
Bar Seal	48.4	5/32
Bar Seal		

	No. of Feet
Tear Seal	
Bar Seal	
Bar Seal	

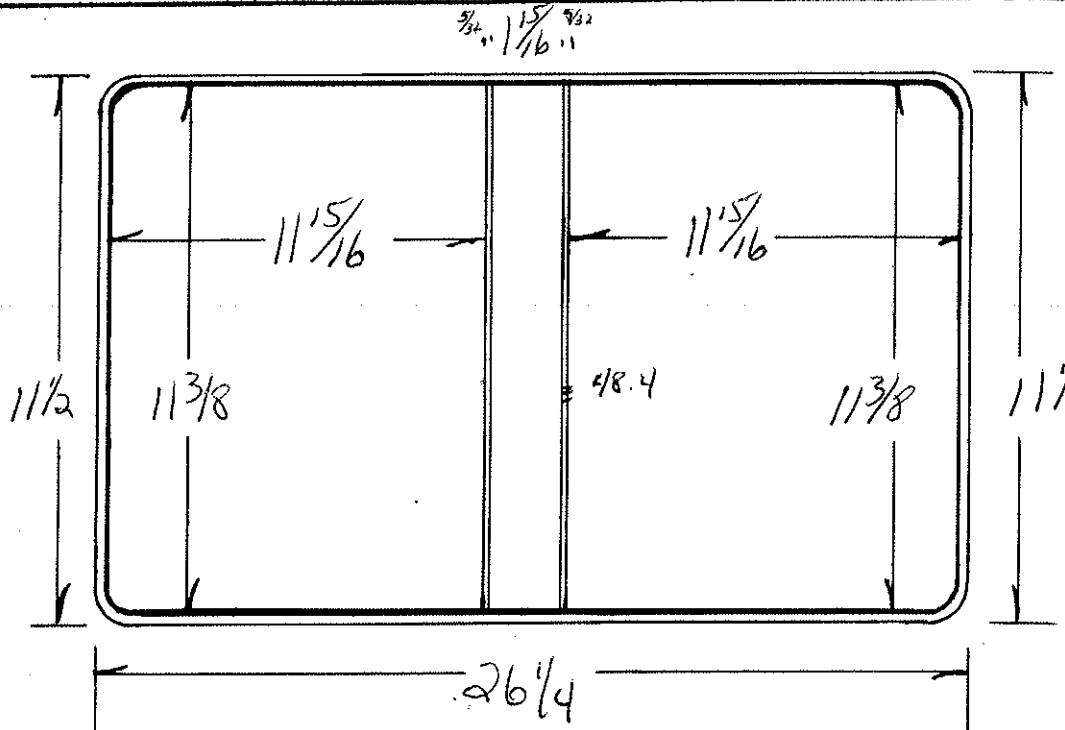

Dwg. Jim

Code	Ga.	#	Cutting Specs		Code	Ga.	#	Cutting Specs	
			Size	Out				Size	Out
Cover Mat.			12 1/4 x 27	1	Lining Mat.			24 1/4 x 27	1
Cover Mat			X		Lining Mat.			X	
COL Pckt.			11 3/4 x 27	1	Horz. Pckt.			5 3/8 x 12 1/2	1
Vert. Pckt.			X		Horz. Pckt.			X	
Pocket			X		Pocket			X	
Label Holder			X		Card Holder			X	
Material			X		Material			X	
Material			X		Material			X	
Material			X		Material			X	
F.C. Board			11 9/32 x 11 27/32	100	B.C. Board			11 5/16 x 11 7/8	100
B.C. Board			11 9/32 x 11 27/32	100	F.B. Board			11 5/16 x 11 7/8	100
Center Board			11 9/32 x 1 27/32	100	Board			11 5/16 x 1 27/32	100
Board			X		Strip			X	
Cover Pad			X		Strip			X	
					B.B. Pad			X	

Matched Sample

Angle D

DIE # 5307	STYLE CASE VRB	LOCATION D18-3
SHEET SIZE 11 x 8 1/2 + 1/2	CAP. 1/2	ORDER NO. 64885
CUSTOMER EBSCO Media	DUE DATE	

QUANTITY	6000
DATE	4-5-93

RADIUS	3/8
COMPLETED	

TEAR SEAL	.014
BAR SEAL	483

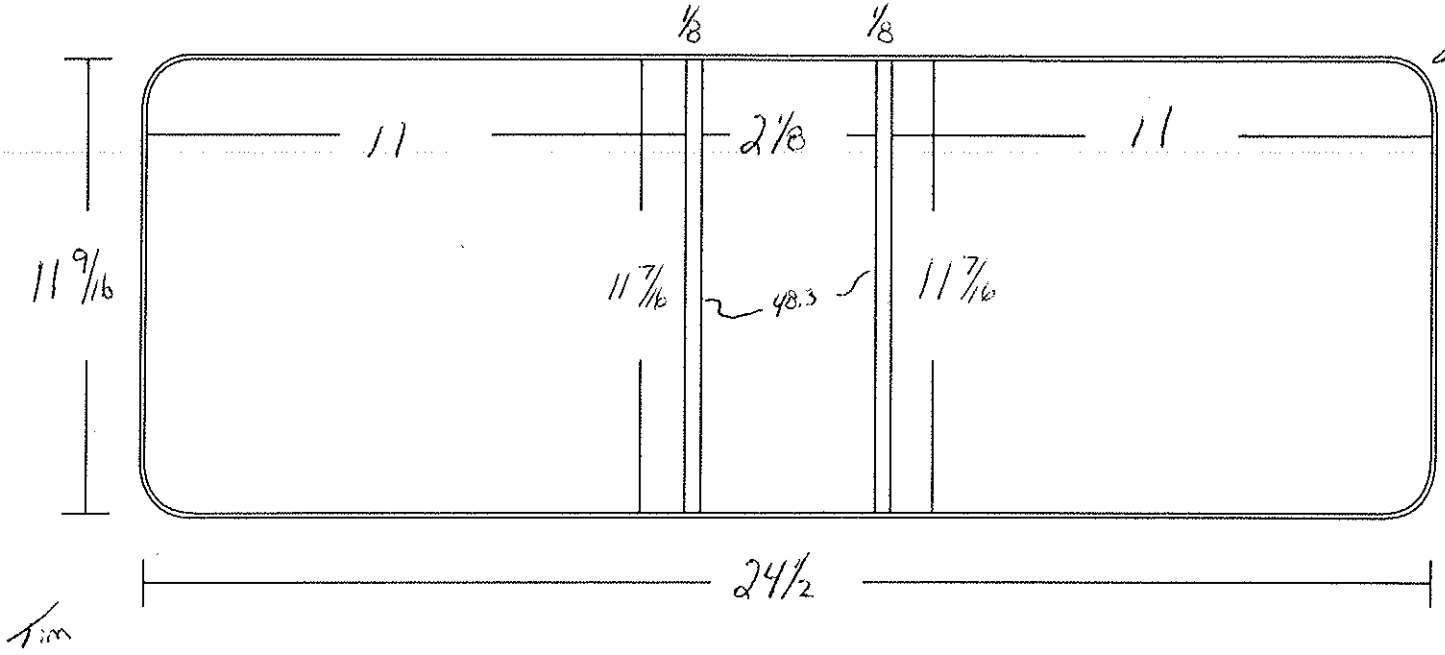

MATERIAL

	CODE	GA	PCS		CODE	GA	PCS
COVER MATL	12 5/16 X 25 1/4			LINING	12 5/16 X 25 1/4		
COVER MATL	X			LINING	X		
VERT PKT	X			HORZ PKT	4 7/8 X 25 1/4		
VERT PKT	X			HORZ PKT	X		
CARD HOLDER	X			DIAGONAL PKT	X		
COL	X			LABEL HOLDER	X		
EX. COL	X			GUSSETT	X		
	X			REINF.	X		
	X				X		

PRINTS

FRONT COVER	X	BACK BONE	X	BACK COVER	X
-------------	---	-----------	---	------------	---

BOARDS

	CODE	PT	PCS		CODE	PT	PCS
F.C. BOARD	11 3/8 X 10 7/16	100	1	F.C. BOARD	11 1/32 X 10 29/32	120	1
B.B. BOARD	11 3/8 X 2 1/32	100	1	B.B. BOARD	11 1/32 X 2 1/32	120	1
B.C. BOARD	11 3/8 X 10 15/16	100	1	B.C. BOARD	11 1/32 X 10 29/32	120	1
B. UP STRIP	X				X		
	X				X		

Product Code

Style Case

Angle D VRR

Sheet Size X

Cap. 2 1/2

Die No. 5390

Order No. 975718

Plate E5-2

Customer

Valvoline Inc.

Metal
Total Vinyl
Quantity 1000
Date 8-4-93
Type Corners RND
Radius 59
Completed

	Gauge
Bar Seal	.012
Bar Seal	484
Bar Seal	

	No. of
Bar Seal	
Bar Seal	
Bar Seal	

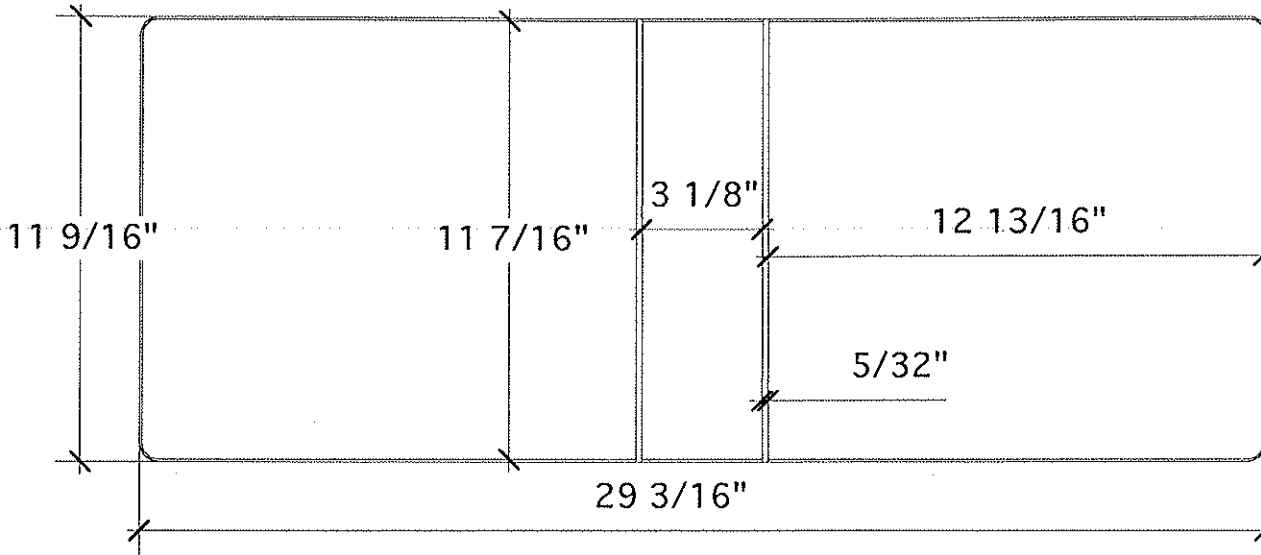

Tim

Code	Ga.	PCS	Cutting Specs		Code	Ga.	Pcs.	Cutting Specs.	
			Size	Out				Size	Out
Cover Mat.		1	12 5/16 X	30	Lining Mat.		1	12 5/16 X	30
Cover Mat.			X		Lining Mat.			X	
Ext. Pckt.			X		Horz. Pckt.			X	
Ext. Pckt.			X		Horz. Pckt.			X	
Picture Pocket		1	12 5/16 X	30	Pocket		1	5 7/8 X	13 3/16
Label Holder			X		Card Holder			X	
Material			X		Material			X	
Material			X		Material			X	
Material			X		Material			X	
B.C. Board		100	11 3/8 X	12 3/4	B.C. Board		120	11 11/32 X	12 23/32
B.C. Board		100	11 3/8 X	3 1/32	B.B. Board		120	11 11/32 X	3 1/32
Center Board		100	11 3/8 X	12 3/4	Board		120	11 11/32 X	12 23/32
Board			X		Strip			X	
Cover Pad			X		Strip			X	
					B.B. Pad			X	

Per Sample

Angle

DIE #	5398	STYLE CASE	VRB Dring	LOCATION	E5-4
SHEET SIZE	11 X 9 +	CAP.	4"	ORDER NO.	975857
CUSTOMER	Semen Energy & Automation			DUE DATE	

QUANTITY	3
DATE	8-12-93

RADIUS	3/8
COMPLETED	

TEAR SEAL	014
BAR SEAL	484

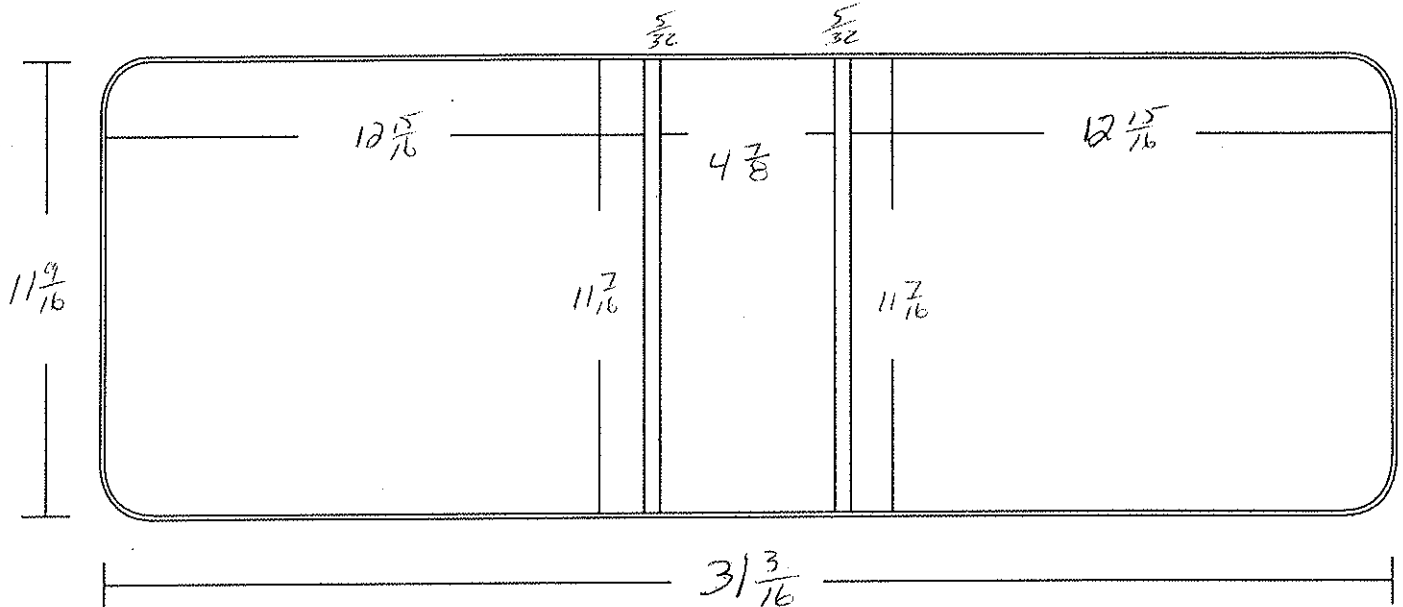

Binder will hold open per customer

MATERIAL

	CODE		GA	PCS		CODE		GA	PCS
COVER MATL		12 5/16 X 31 15/16		1	LINING		12 5/16 X 31 15/16		1
COVER MATL		X			LINING		X		
VERT PKT		X			HORZ PKT		X		
VERT PKT		X			HORZ PKT		X		
CARD HOLDER		X			DIAGONAL PKT		X		
COL		X			LABEL HOLDER		4 5/8 X 5 5/16		1
EX. COL		X			GUSSETT		X		
		X			REINF.		X		
		X					X		

PRINTS

FRONT COVER	X	BACK BONE	X	BACK COVER	X
-------------	---	-----------	---	------------	---

BOARDS

	CODE		PT	PCS		CODE		PT	PCS
F.C. BOARD		11 1/32 X 12 27/32	134	1	F.C. BOARD		X		
B.B. BOARD		11 1/32 X 4 25/32	134	1	B.B. BOARD		X		
B.C. BOARD		11 1/32 X 12 27/32	134	1	B.C. BOARD		X		
B. UP STRIP		X					X		
		X					X		

STD - NB

DIE # 5562		STYLE CASE VINLY D RING BINDER		LOCATION E3-9	
SHEET SIZE 11 X 8 1/2 + 1/2		CAP. 1 3/4		ORDER # 67765	
CUSTOMER EBSCO MEDIA				DUE DATE	
QUANTITY		RADIUS	3/8	TEAR SEAL	.012
DATE		COMPLETED		BAR SEAL	484

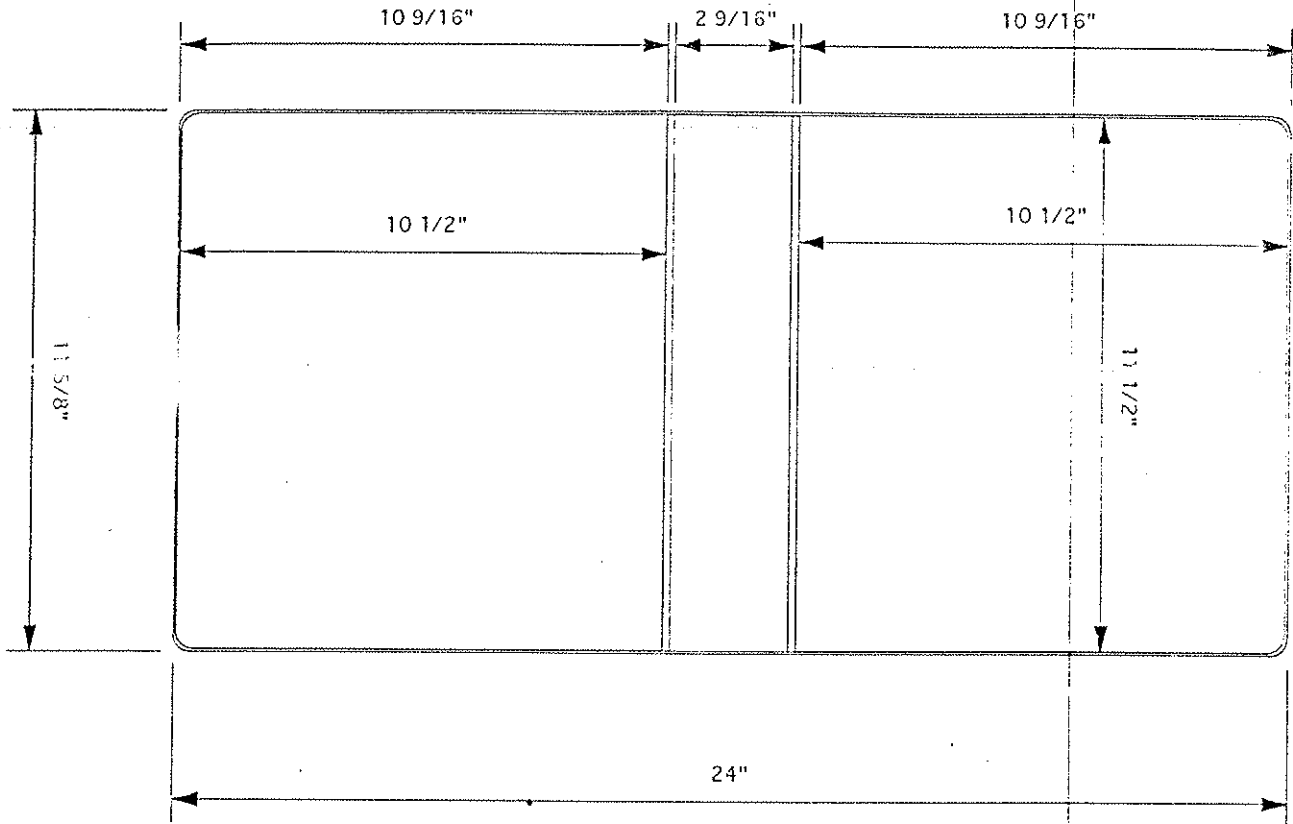

MATERIAL SPECS		GA		PCS	
COVER MATL	12 3/8 X 24 3/4	1	LINING	12 3/8 X 24 3/4	1
COVER MATL			LINING		
VERT PKT			HORZ PKT		
VERT PKT			HORZPKT		
CARD HOLDER			DIAGONAL PKT		
COL			LABEL HOLDER		
DIE CUT COL	13 3/8 X 25 3/4	1	GUSSETT		
			REINF		

BOARD SPECS					
F.C. BOARD	11 7/16 X 10 7/16	100	1	F.C. BOARD	
B.B. BOARD	11 7/16 X 2 15/32	100	1	B.B. BOARD	
B.C. BOARD	11 7/16 X 10 7/16	100	1	B.C. BOARD	
BU STRIP					

Special Size

DIE #	7104	METAL	3.5 ANGLE D	RADIUS	3/8"
ORDER #	431417	CUSTOMER	SANDE WELLS	TEAR SEAL	BLIND
SHEET SIZE	11 X 9	STYLE CASE	VINYL BINDER	BAR SEAL	48-4
CAP.	3 1/2"	DUE DATE	7-4-01	COMPLETED	
LOCATION		QUANTITY	5000	DATE	6-4-01

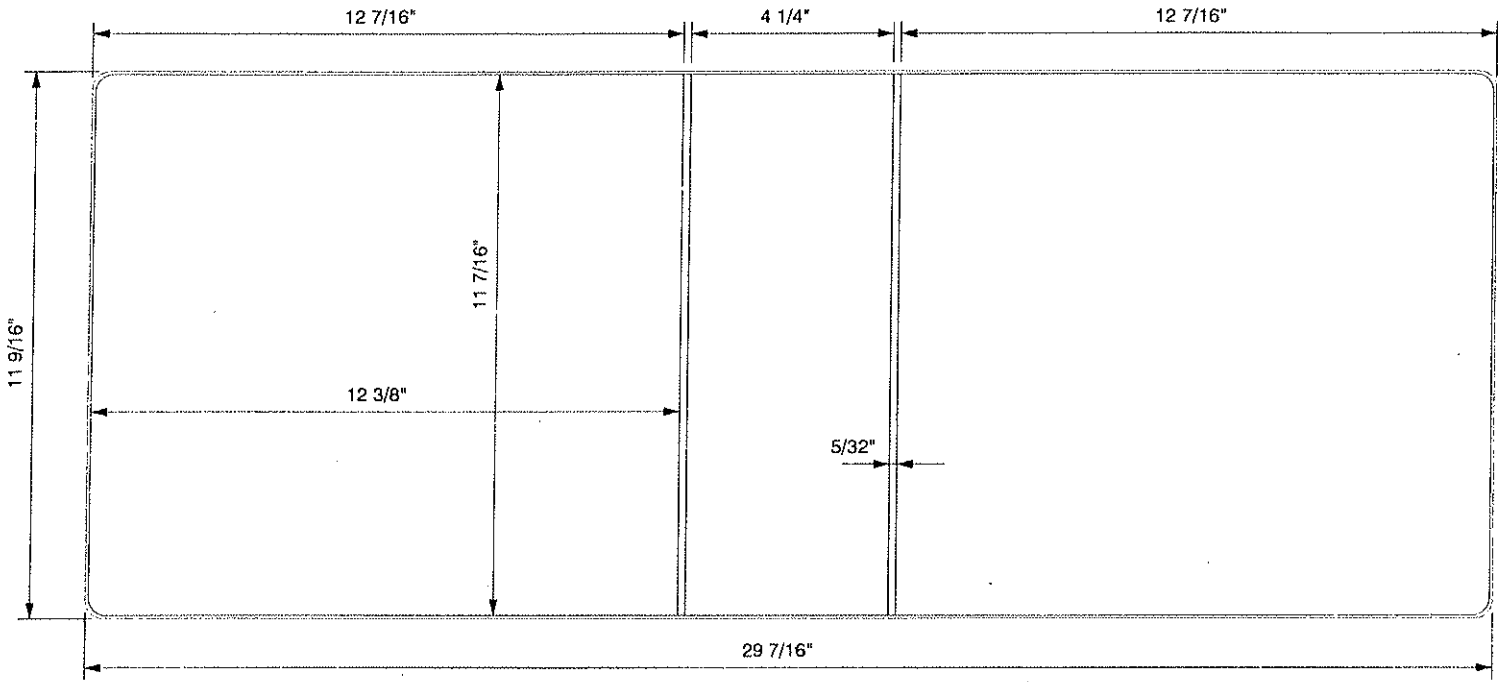

MATERIAL SPECS		GAUGE	PCS.	MATERIAL SPECS		GAUGE	PCS.
COVER MAT.	12 5/16 X 30 1/4		1	LINING MAT.	12 5/16 X 30 1/4		1
COVER MAT.				LINING MAT.			
DIE CUT				HORZ. PKT.			
COL				VERT. PKT.			
LABEL HOLDER				DIE CUT			
GUSSET				REINF.			

BOARD SPECS		GAUGE	PCS.	BOARD SPECS		GAUGE	PCS.
	5/16" R. CORNERS				5/16" R. CORNERS		
F.C. BOARD	11 3/8 X 12 5/16	100	1	F.C. BOARD			
B.B. BOARD	11 3/8 X 4 5/32	100	1	B.B. BOARD			
B.C. BOARD	11 3/8 X 12 5/16	100	1	B.C. BOARD			
FLAP BD.				DIE CUT			
BOARD				DIE CUT			

DIE #	7398	METAL	ANGLE D	RADIUS	3/8"
ORDER #	544411	CUSTOMER	INTERFACE INC.	TEAR SEAL	BLIND
SHEET SIZE	11 X 9	STYLE CASE	VINYL BINDER	BAR SEAL	48-4
CAP.	3"	DUE DATE	3-10-03	COMPLETED	
LOCATION		QUANTITY	2	DATE	3-6-03

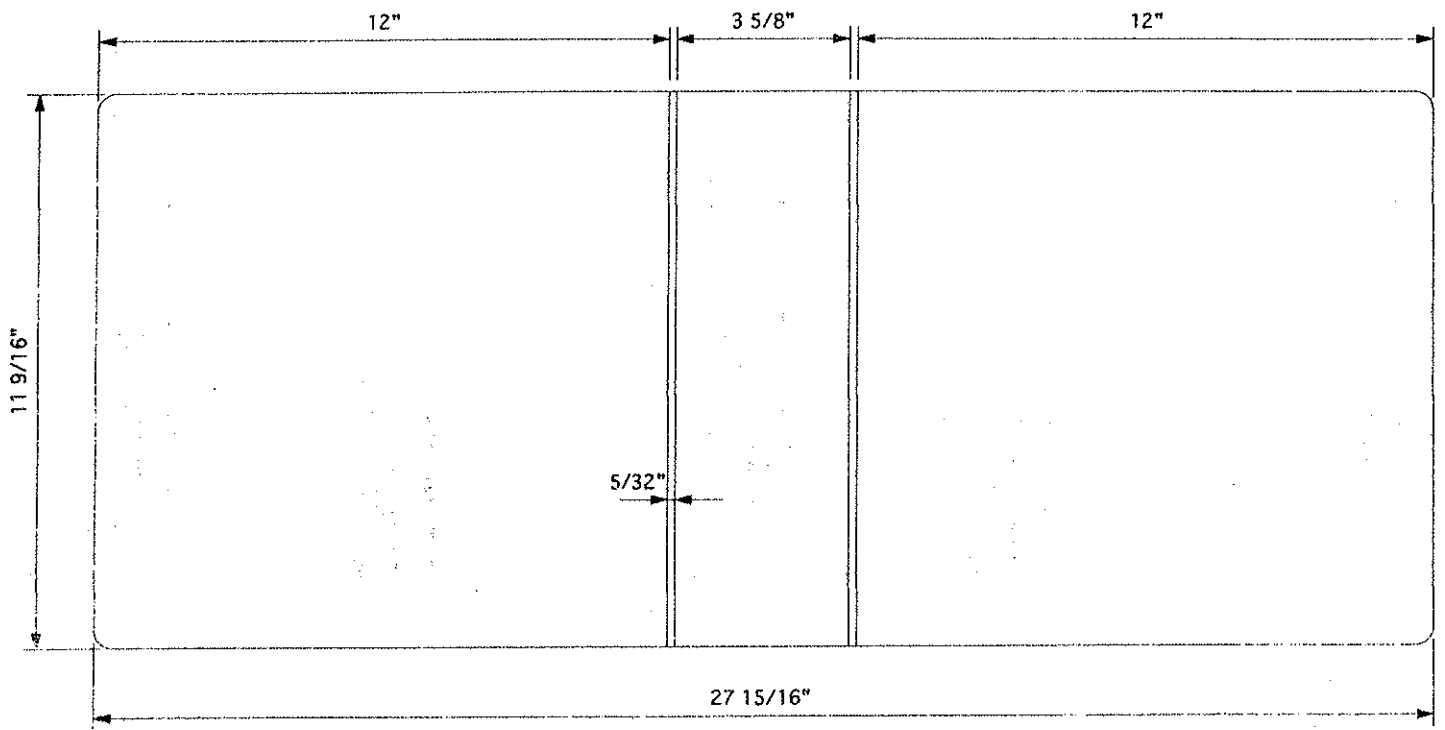

MATERIAL SPECS		GAUGE	PCS.	MATERIAL SPECS		GAUGE	PCS.
COVER MAT.	12 1/4 X 28 11/16		1	LINING MAT.	12 1/4 X 28 11/16		1
COVER MAT.				LINING MAT.			
DIE CUT				HORZ. PKT.			
COL				VERT. PKT.			
LABEL HOLDER				DIE CUT			
GUSSET				REINF.			
BOARD SPECS	5/16" R. CORNERS	GAUGE	PCS.	BOARD SPECS	5/16" R. CORNERS	GAUGE	PCS.
F.C. BOARD	11 7/16 X 11 7/8		1	F.C. BOARD			
B.B. BOARD	11 7/16 X 3 17/32		1	B.B. BOARD			
B.C. BOARD	11 7/16 X 11 7/8		1	B.C. BOARD			
FLAP BD.				DIE CUT			
BOARD				DIE CUT			

DIE #	8222	METAL	AD	RADIUS	3/8"
ORDER #	757847	CUSTOMER	DOCUSOURCE OF NC	TEAR SEAL	.012
SHEET SIZE	11 X 9 1/2	STYLE CASE	VINYL BINDER	BAR SEAL	48-4
CAP.	2"	DUE DATE	11-1-06	COMPLETED	
LOCATION		QUANTITY	510	DATE	10-16-06

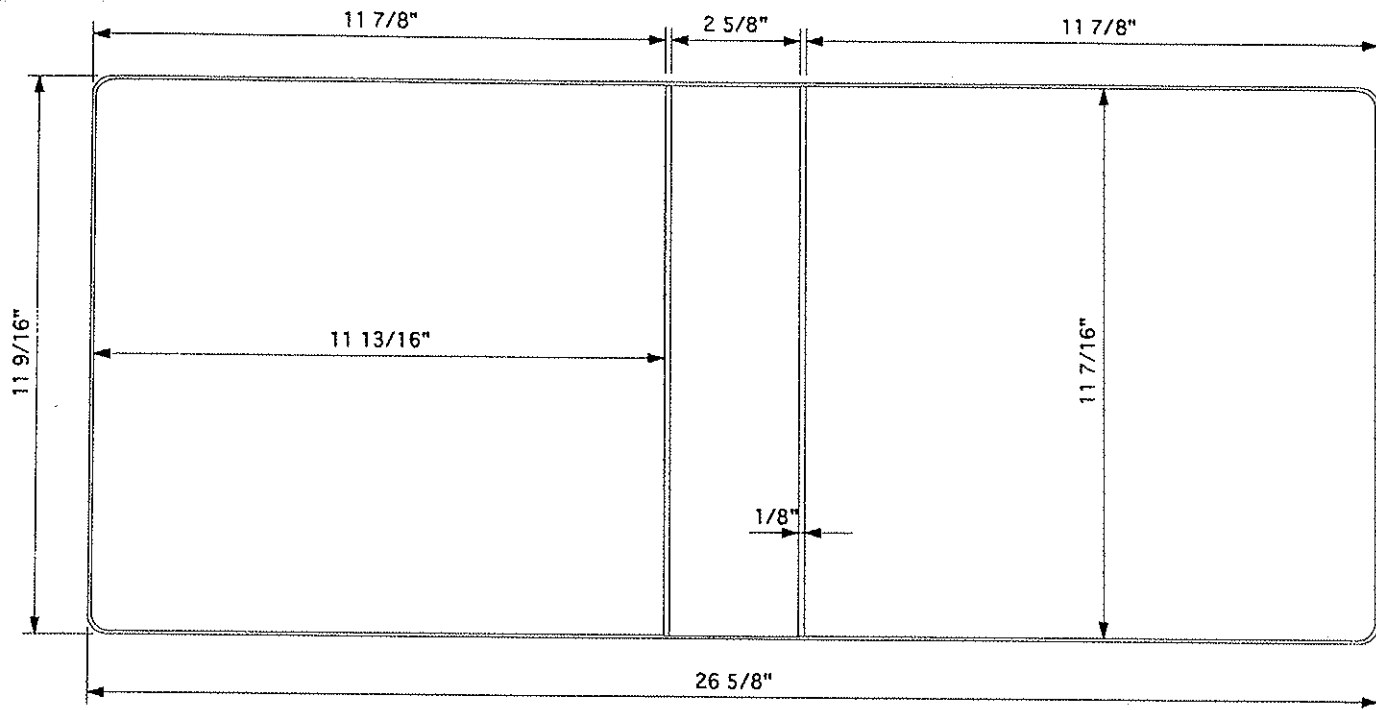

MATERIAL SPECS		GAUGE	PCS.	MATERIAL SPECS		GAUGE			
COVER MAT.	12 5/16 X 27 3/8		1	LINING MAT.	12 5/16 X 27 3/8				
COVER MAT.				LINING MAT.					
DIE CUT				HORZ. PKT.	4 7/8 X 27 3/8				
COL	11 11/16 X 15 5/8		1	VERT. PKT.					
LABEL HOLDER				DIE CUT					
GUSSET				REINF.					
BOARD SPECS		5/16" R. CORNERS		GAUGE	PCS.	BOARD SPECS	5/16" R. CORNERS		GAUGE
F.C. BOARD	11 3/8 X 11 3/4	120	1	F.C. BOARD					
B.B. BOARD	11 3/8 X 2 17/32	120	1	B.B. BOARD					
B.C. BOARD	11 3/8 X 11 3/4	120	1	B.C. BOARD					
FLAP BD.				DIE CUT					
BOARD				DIE CUT					

DIE #	8653	METAL	ANGLE D ONLY	RADIUS	3/8"
ORDER #		CUSTOMER		TEAR SEAL	.016
SHEET SIZE	11 X 9	STYLE CASE	NEW STOCK	BAR SEAL	48-4
CAP.	1"	DUE DATE		COMPLETED	
LOCATION		QUANTITY		DATE	6-30-04

PULL D3-100-AD AND INSERT STEPPED BRASS.

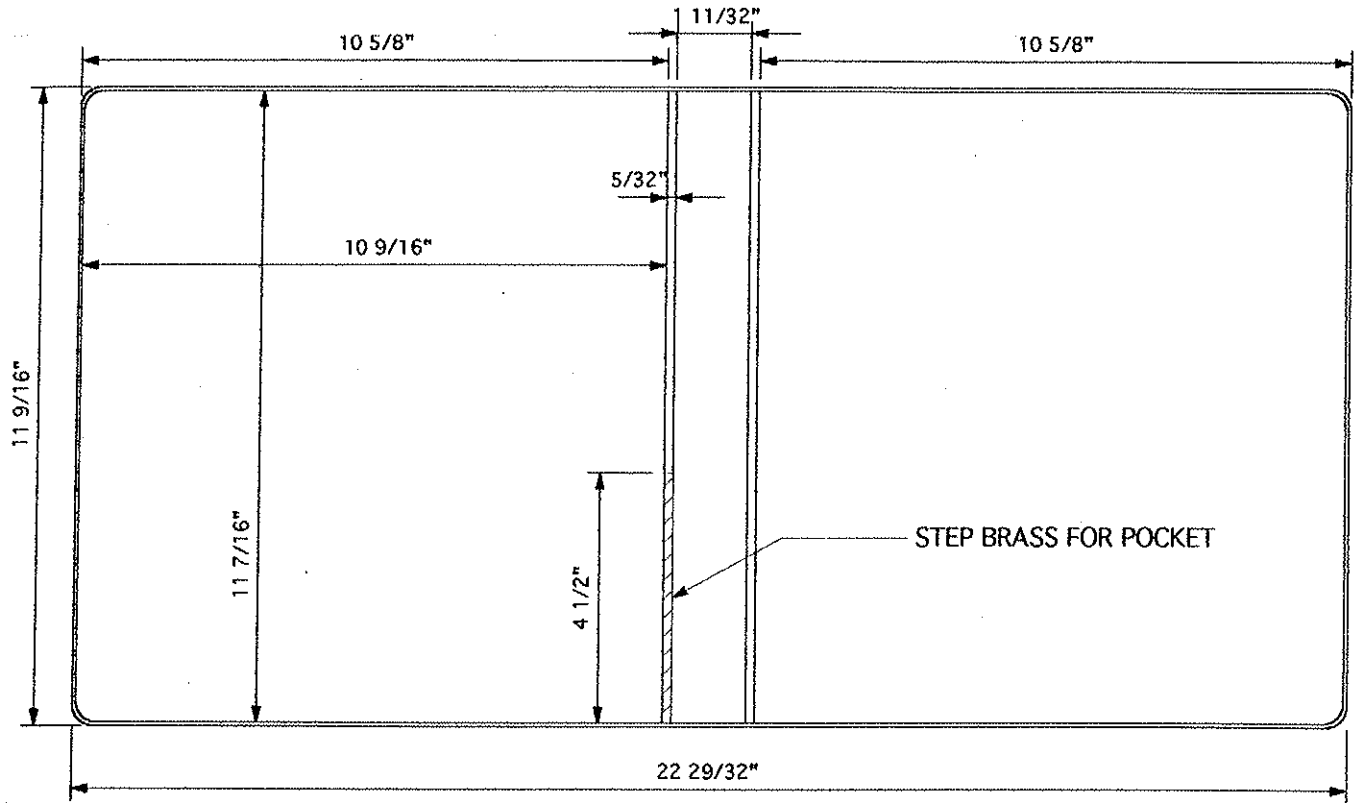

MATERIAL SPECS		GAUGE	PCS.	MATERIAL SPECS		GAUGE	PCS.
COVER MAT.	12 1/4 X 23 11/16		1	LINING MAT.	12 1/4 X 23 11/16		1
PADDED COVER				LINING MAT.			
PICTORIAL	12 1/4 X 23 11/16		1	5" HORZ.			
COL				4.5" HORZ.			
EX COL NO TRIM				ONE SIDED			
EX COL				ONE SIDED	4 7/8 X 11 1/8		1

BOARD SPECS		PART NUMBER	GAUGE	PCS.
BOARD	11 3/8 X 10 15/32	030012	90	1
B.B. BOARD	11 3/8 X 1 1/4	030013	90	1
B.B. BOARD	11 3/8 X 1 1/4	030034	118	1
BOARD	11 3/8 X 10 15/32	030028	118	1

DIE #	8654	METAL	ANGLE D ONLY	RADIUS	3/8"
ORDER #		CUSTOMER		TEAR SEAL	.016
SHEET SIZE	11 X 9	STYLE CASE	NEW STOCK	BAR SEAL	48-4
CAP.	1 1/2"	DUE DATE		COMPLETED	
LOCATION		QUANTITY		DATE	6-30-04

PULL D3-150-AD AND INSERT STEPPED BRASS.

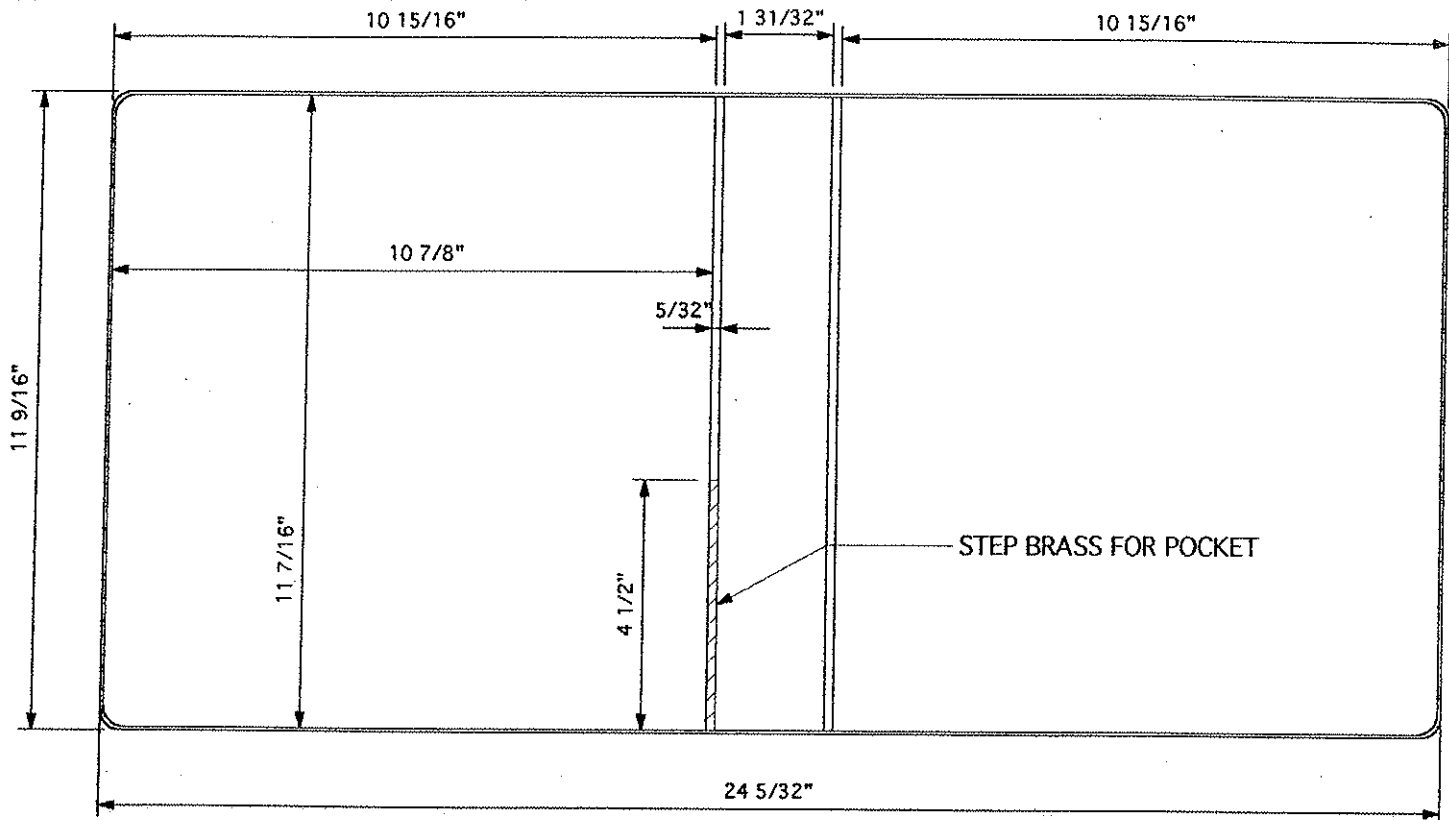

MATERIAL SPECS		GAUGE		MATERIAL SPECS		GAUGE	
COVER MAT.	12 1/4 X 24 7/8	1		LINING MAT.	12 1/4 X 24 7/8	1	
PADDED COVER				LINING MAT.			
PICTORIAL	12 1/4 X 24 7/8	1		5" HORZ.			
COL				4.5" HORZ.			
EX COL NO TRIM				ONE SIDED			
EX COL				ONE SIDED	4 7/8 X 11 1/2		1

BOARD SPECS		PART NUMBER		GAUGE	
BOARD	11 3/8 X 10 25/32	030014	90	1	
B.B. BOARD	11 3/8 X 1 7/8	030015	90	1	
B.B. BOARD	11 3/8 X 1 7/8	030035	118	1	
BOARD	11 3/8 X 10 25/32	030030	118	1	

DIE #	8655	METAL	AD LOCKING	RADIUS	3/8"
ORDER #	881493	CUSTOMER	DORMA GROUP	TEAR SEAL	.014
SHEET SIZE	11 X 9	STYLE CASE	VINYL BINDER W/HOLE	BAR SEAL	48-4
CAP.	2"	DUE DATE	2-25-09	COMPLETED	
LOCATION		QUANTITY	300	DATE	2-4-09

*** WARNING DRAWING NOT ACTUAL SIZE ***

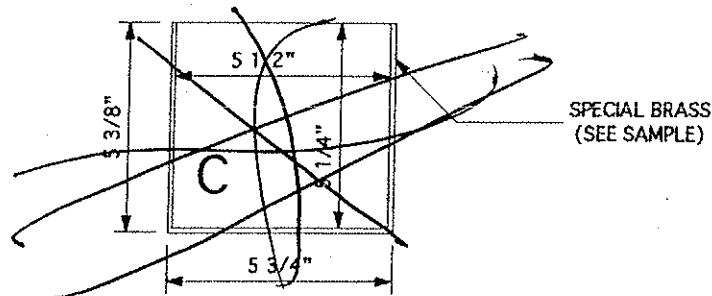
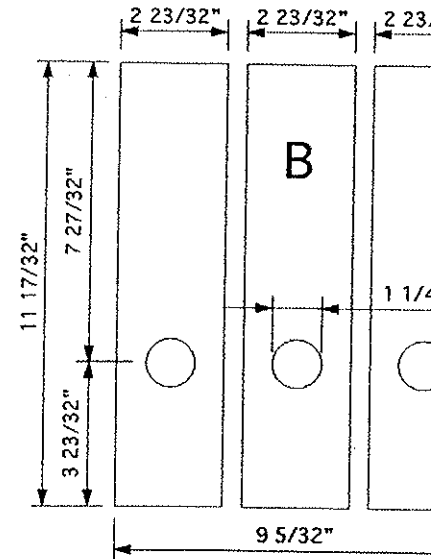
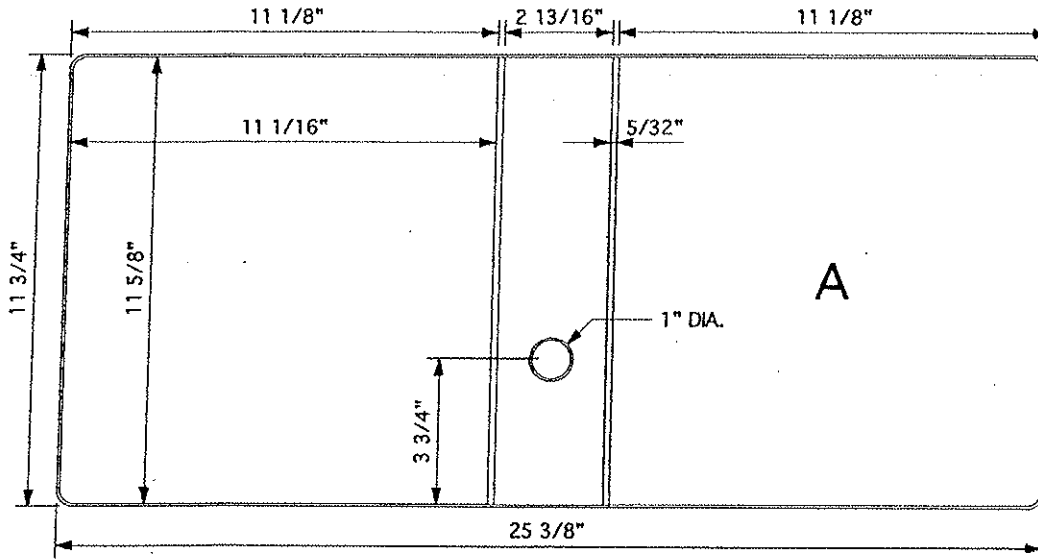

MATERIAL SPECS		GAUGE	PCS.	MATERIAL SPECS		GAUGE	PCS.				
COVER MAT.	12 1/2 X 26 1/8		1	LINING MAT.	12 1/2 X 26 1/8		1				
COVER MAT.				LINING MAT.							
DIE CUT				HORZ. PKT.	5 3/8 X 5 3/4	C	1				
COL				VERT. PKT.							
LABEL HOLDER				DIE CUT							
GUSSET				REINF.							
BOARD SPECS		5/16" R. CORNERS		GAUGE	PCS.	BOARD SPECS		5/16" R. CORNERS		GAUGE	PCS.
F.C. BOARD	11 9/16 X 11	120	1	F.C. BOARD							
B.B. BOARD				B.B. BOARD							
B.C. BOARD	11 9/16 X 11	120	1	B.C. BOARD							
FLAP BD.				DIE CUT							
BOARD				DIE CUT B	12 1/2 X 10 1/8	30UT	120				1

DIE #	8700	METAL	AD	RADIUS	3/8"
ORDER #		CUSTOMER	DORMA GROUP	TEAR SEAL	.014
SHEET SIZE	11 X 9	STYLE CASE	VINYL BINDER W/HOLE	BAR SEAL	48-4
CAP.	2 1/2"	DUE DATE		COMPLETED	
LOCATION		QUANTITY		DATE	

*** WARNING DRAWING NOT ACTUAL SIZE ***

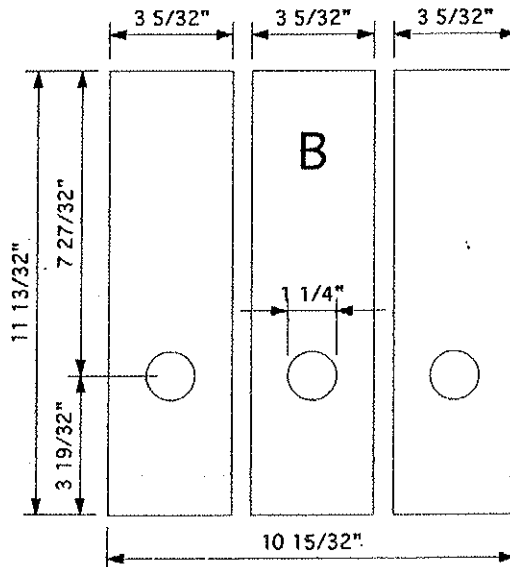
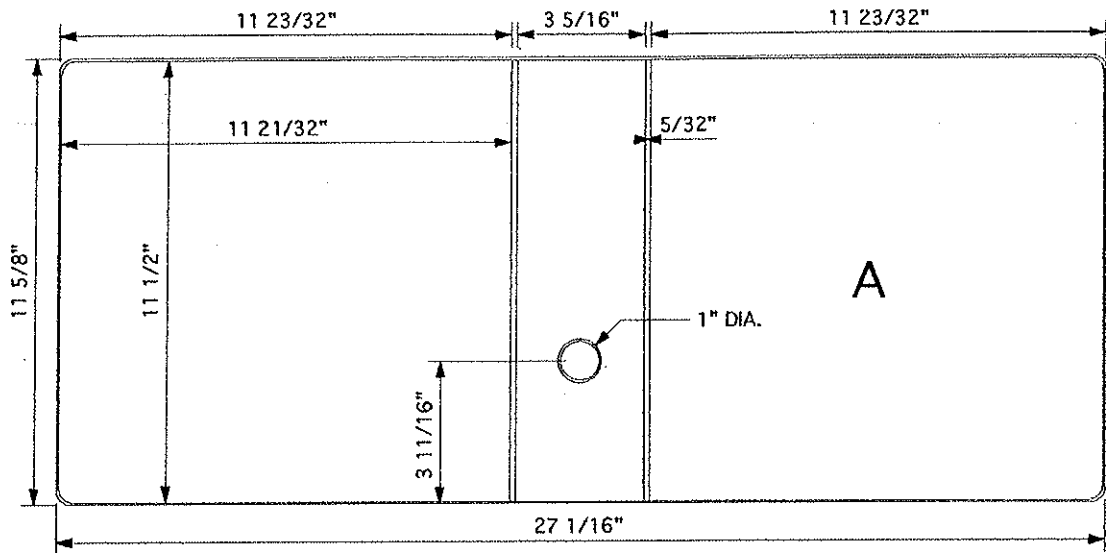

MATERIAL SPECS		GAUGE	PCS.	MATERIAL SPECS	GAUGE	PCS.
COVER MAT.	12 3/8 X 27 13/16		1	LINING MAT.	12 3/8 X 27 13/16	1
LABEL HOLDER				DIE CUT		
GUSSET				REINF.		
BOARD SPECS		GAUGE	PCS.	BOARD SPECS	GAUGE	PCS.
F.C. BOARD	11 13/32 X 11 9/16	120	1	F.C. BOARD		
B.B. BOARD				B.B. BOARD		
B.C. BOARD	11 13/32 X 11 9/16	120	1	B.C. BOARD		
FLAP BD.				DIE CUT		
BOARD				DIE CUT B	12 3/8 X 11 1/2	30UT 120 1