

Product Code

Style Case

U Ring

Back Cover

Sheet Size  $8\frac{1}{2} \times 16\frac{5}{8}$  Cap. 1

Die No. 3346

Order No. 69845

Plate

Customer

Material

Total Vinyl

Quantity

Date

Type Corners

Radius  $3/8$

Completed

Stack

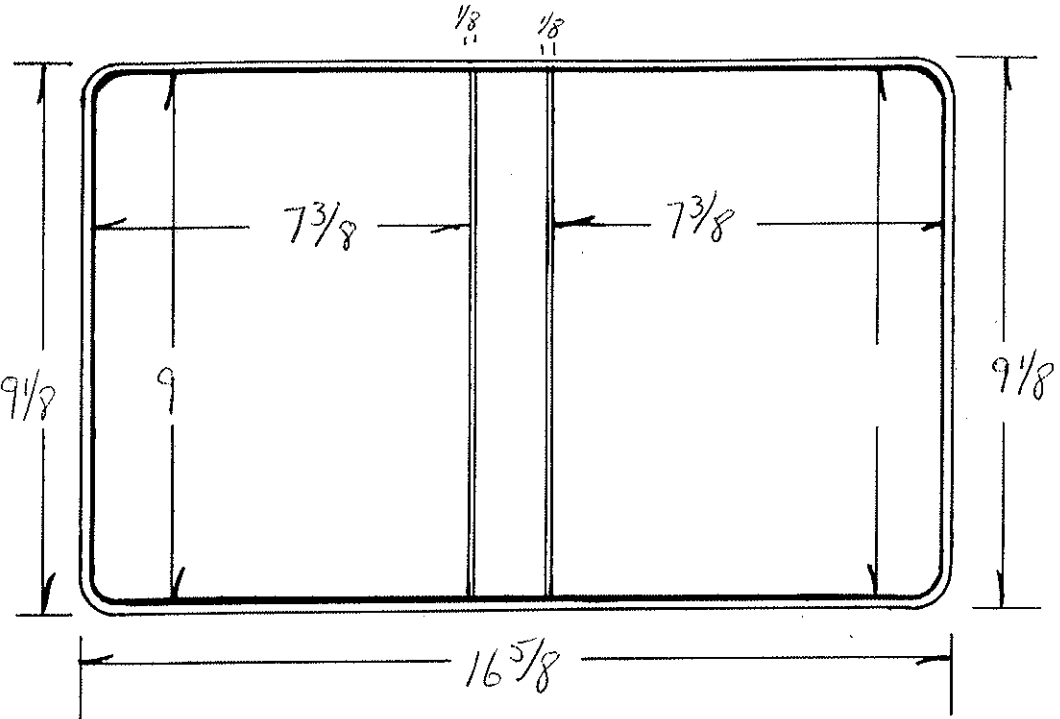

	Gauge	Thick
ear Seal		
ar Seal		
ar Seal		

	No. of Feet
ear Seal	
ar Seal	
ar Seal	

Draw. Jim  
To go with  
die # 3347

Code	Ga.	PCS	Cutting Specs		Code	Ga.	Pcs.	Cutting Specs	
			Size	Out				Size	Out
Cover Mat.		1	$9\frac{3}{4} \times 17\frac{3}{8}$		Lining Mat.		1	$9\frac{3}{4} \times 17\frac{3}{8}$	
Cover Mat			X		Lining Mat.			X	
Vert. Pckt.	13B1el	1	$9\frac{3}{4} \times 2\frac{1}{2}$		Horz. Pckt.		1	$9\frac{5}{16} \times 11\frac{3}{8}$	
Vert. Pckt.			X		Horz. Pckt.			X	
Pocket			X		Pocket	COL		$9\frac{1}{4} \times 10\frac{1}{8}$	
Label Holder			X		Card Hlder			X	
Material			X		Material			X	
Material			X		Material			X	
Material			X		Material			X	
B.C. Board		100	$8\frac{29}{32} \times 7\frac{9}{32}$	1	B.C. Board		100	$8\frac{15}{16} \times 7\frac{5}{16}$	1
B.C. Board		100	$8\frac{29}{32} \times 7\frac{9}{32}$	1	B.B. Board		100	$8\frac{15}{16} \times 7\frac{5}{16}$	1
Center Board		100	$8\frac{29}{32} \times 1\frac{13}{32}$	1	Board		100	$8\frac{15}{16} \times 1\frac{13}{32}$	1
Board			X		Strip			X	
Cover Pad			X		Strip			X	
					B.B. Pad			X	



Product Code Special Size

Style Case U.S. Ring straight D 1/16

Sheet Size 8 1/2 X 7 1/2 Cap. 1 1/2

Die No. 3649

Order No. 953692

Plate

Customer

TCS Software

Metal
Total Vinyl <u>.030</u>
Quantity <u>600</u>
Date <u>12-12-86</u>
Type Corners <u>Rd</u>
Radius <u>1/4</u>
Completed <u>1-2-87</u>

	Gauge	Thick
Tear Seal	<u>Feather edge</u>	
Bar Seal	<u>23</u>	<u>1/2</u>
Bar Seal		

	No. of Feet
Tear Seal	
Bar Seal	
Bar Seal	

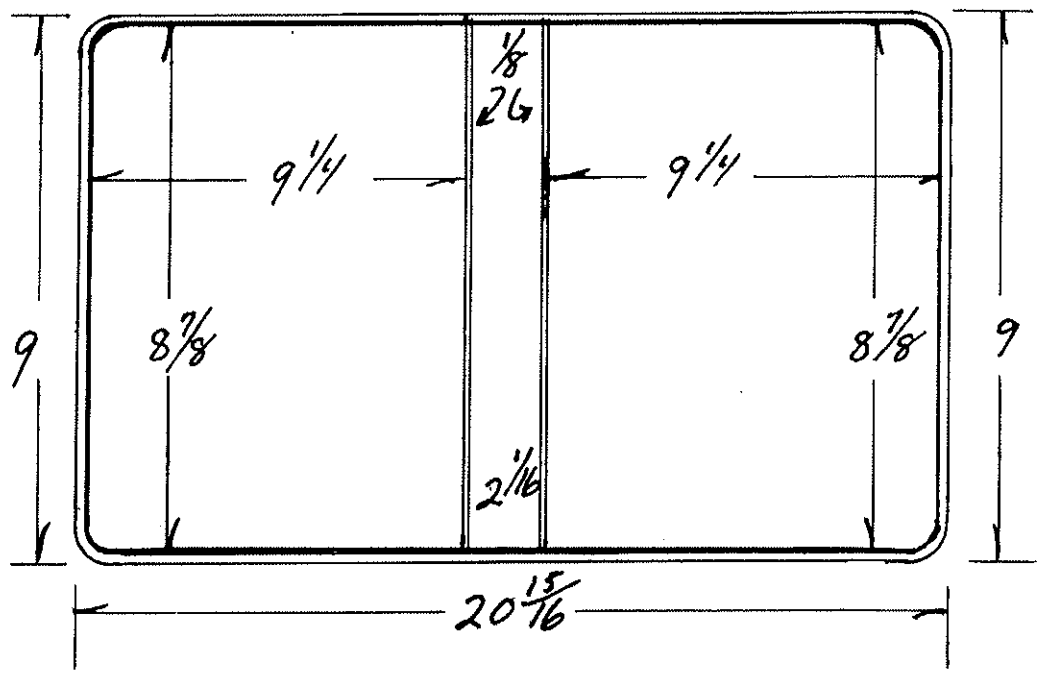

Code	Ga.	#	Cutting Specs		Code	Ga.	#	Cutting Specs	
			Size	Out				Size	Out
Cover Mat.			$9 \frac{5}{8} X 21 \frac{11}{16}$	1	Lining Mat.			$9 \frac{5}{8} X 21 \frac{11}{16}$	1
Cover Mat			X		Lining Mat.			X	
Vert. Pckt.			X		Horz. Pckt.			$9 \frac{5}{8} X 21 \frac{15}{16}$	1
Vert. Pckt.			X		Horz. Pckt.			X	
Pocket			X		Pocket			X	
Label Holder			X		Card Holder			X	
Material			X		Material			X	
Material			X		Material			X	
Material			X		Material			X	
F.C. Board			$8 \frac{25}{32} X 9 \frac{5}{32}$	1	B.C. Board			$8 \frac{25}{32} X 9 \frac{5}{32}$	1
B.C. Board			X		B.B. Board			$8 \frac{25}{32} X 13 \frac{1}{32}$	1
Center Board			X		Board			X	
Board			X		Strip			X	
Cover Pad			X		Strip			X	
					B.B. Pad			X	

Product Code

8 1/2 x 15 1/2 + 1/2 - 1"

2-up Die 5880

Style Case

Ring Binder

AS Sample

Sheet Size

X

Cap.

Die No. 3657

Order No. 953580

Plate

Customer

Associated Computer Service

Metal
Total Vinyl .030
Quantity 250
Date 11-7-86
Type Corners R
Radius 1/4
Completed

Gauge	Thick
Tear Seal .016	3/32
Bar Seal 72	1/8
Bar Seal	

No. of Feet	
Tear Seal	
Bar Seal	
Bar Seal	

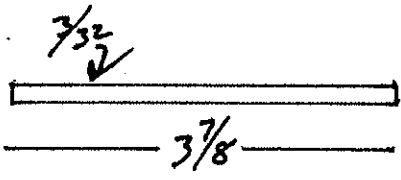
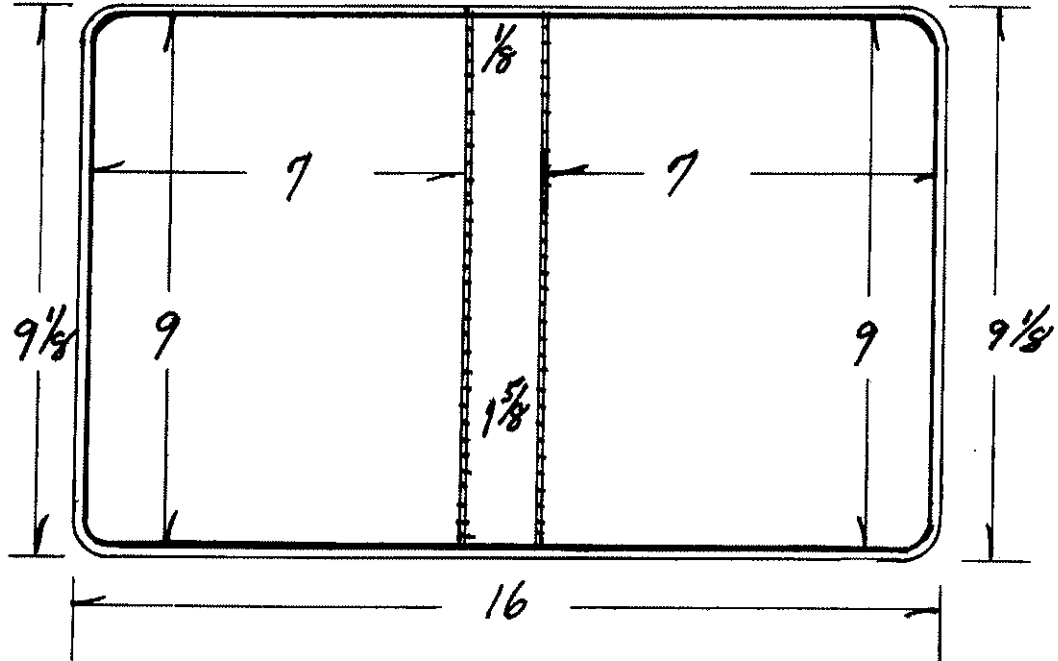

Code		Cutting Specs				Code		Cutting Specs			
		Ga.	# PCS	Size	Out			Ga.	# Pcs.	Size	Out
Cover Mat.	9 3/4 X 16 3/4		1			Lining Mat.	9 3/4 X 16 3/4		1		
Cover Mat	X					Lining Mat.	X				
Vert. Pckt.	X					Horz. Pckt.	9 7/16 X 9 1/4		1		
Vert. Pckt.	X					Horz. Pckt.	3 7/16 X 7 9/16		1		
Pocket	X					Pocket	4 3/8 X 7 5/8				
Label Holder	X					Card Holder	4 3/8 X 16 3/4				
Material	X					Material	X				
Material	X					Material	X				
Material	X					Material	X				
B.C. Board	8 29/32 X 6 29/32	120	1			B.C. Board	8 29/32 X 6 29/32	120	1		
B.C. Board	X					B.B. Board	8 29/32 X 1 1/32	120	1		
Center Board	8 15/16 X 6 15/16	100	2			Board	X				
Board	8 15/16 X 1 17/32	100	1			Strip	X				
Cover Pad	X					Strip	X				
						B.B. Pad	X				

Product Code

Style Case Benson D rings w/10

Sheet Size 8 1/2 X 6 5/8 Cap. 1 1/4 Die No. 3660 Order No. 953563 Plate

Customer

U B+C Sample

Metal
Total Vinyl <u>.032</u>
Quantity <u>1</u>
Date <u>11-7-86</u>
Type Corners <u>R2</u>
Radius <u>1/4</u>
Completed

	Gauge	Thick
Tear Seal	<u>Feather</u>	<u>edge</u>
Bar Seal	<u>.8965</u>	<u>1/2</u>
Bar Seal		

	No. of Feet
Tear Seal	
Bar Seal	
Bar Seal	

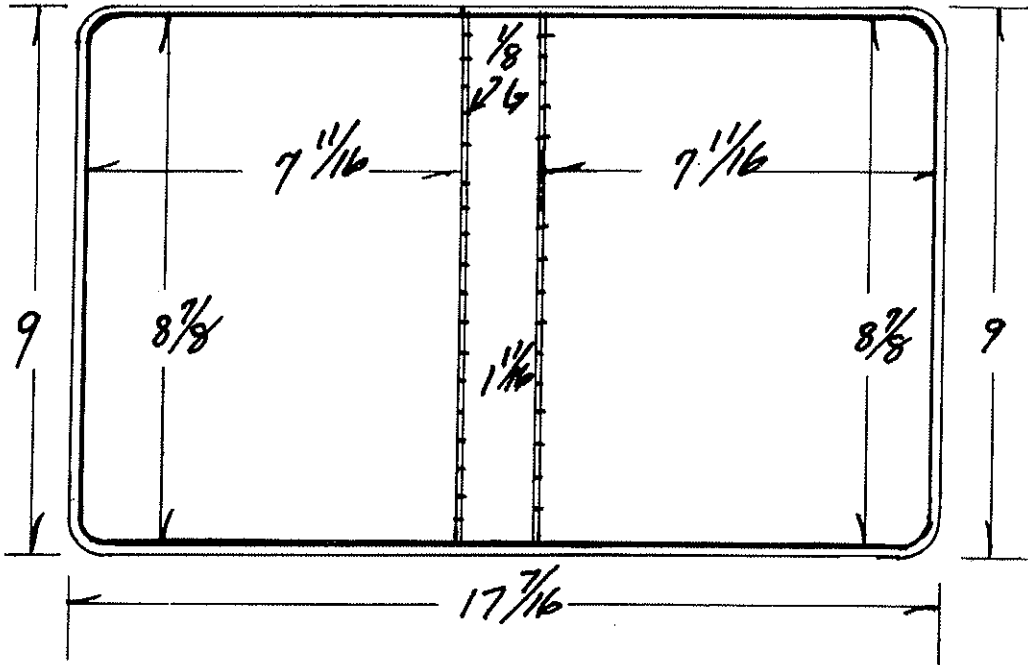

B.B. to be mill  
Down .902

Code		Ga.	#	PCS	Size	Out	Cutting Specs	Code		Ga.	#	PCS	Size	Out	Cutting Specs
Cover Mat.				1	9 3/8 X 18 3/16			Lining Mat.				1			
Cover Mat.					X			Lining Mat.					X		
Vert. Pckt.					X			Horz. Pckt.				1	9 1/16 X 18 1/16		
Vert. Pckt.					X			Horz. Pckt.					X		
Pocket					X			Pocket					X		
Label Holder					X			Card Holder					X		
Material					X			Material					X		
Material					X			Material					X		
Material					X			Material					X		
F.C. Board				1	8 25/32 X 7 19/32			B.C. Board				1	8 25/32 X 7 19/32		
B.C. Board					X			B.B. Board				1	8 25/32 X 1 1/32		
Center Board					X			Board					X		
Board					X			Strip					X		
Cover Pad					X			Strip					X		
								B.B. Pad					X		

Product Code

Style Case U.S. Ring D ring

NOR  
BOOK

Sheet Size 8 1/2 X 6 3/8 Cap. 1 1/4 Die No. 3683 Order No. 953704 Plate

Customer

TEM INC.

Metal
Total Vinyl <u>.030</u>
Quantity <u>1000</u>
Date <u>12-8-86</u>
Type Corners <u>Rd</u>
Radius <u>1/4</u>
Completed

	Gauge	Thick
Tear Seal	<u>1016</u>	<u>3/32</u>
Bar Seal	<u>23</u>	<u>1/8</u>
Bar Seal		

	No. of Feet
Tear Seal	
Bar Seal	
Bar Seal	

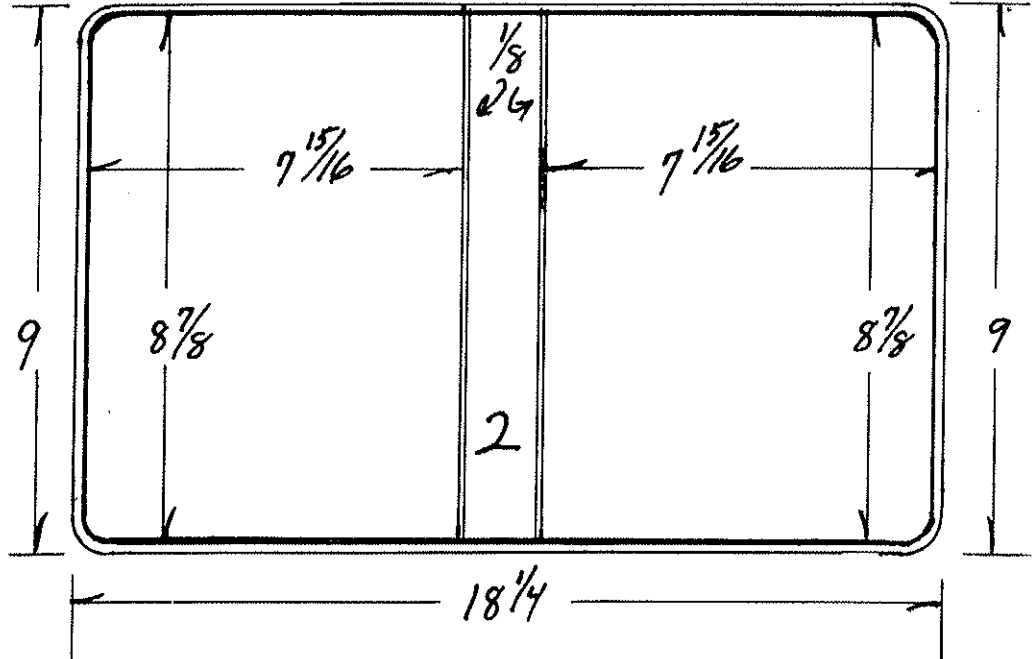

Code	Ga.	PCS	Cutting Specs		Code	Ga.	Pcs.	Cutting Specs	
			Size	Out				Size	Out
Cover Mat.		<u>1</u>	<u>9 5/8 X 19</u>		Lining Mat.		<u>1</u>	<u>9 5/8 X 19</u>	
Cover Mat			X		Lining Mat.			X	
Vert. Pckt.			X		Horz. Pckt.			X	
Vert. Pckt.			X		Horz. Pckt.			X	
Pocket			X		Pocket			X	
Label Holder		<u>1</u>	<u>9 1/16 X 2 1/4</u>		Card Hlder			X	
Material			X		Material			X	
Material			X		Material			X	
Material			X		Material			X	
F.C. Board		<u>1</u>	<u>8 25/32 X 7 1/32</u>		B.C. Board		<u>1</u>	<u>8 25/32 X 7 1/32</u>	
B.C. Board			X		B.B. Board		<u>1</u>	<u>8 25/32 X 1 1/32</u>	
Center Board			X		Board			X	
Board			X		Strip			X	
Cover Pad			X		Strip			X	
					B.B. Pad			X	

Product Code

Style Case Leonard straight D

Sheet Size 8 1/2 X 6 5/8 Cap. 1 1/4 Die No. 3685 Order No. 953870 Plate W 001

Customer

Connections Telecommunications

Metal
Total Vinyl .030
Quantity 300
Date 12-19-86
Type Corners R
Radius 1/4
Completed

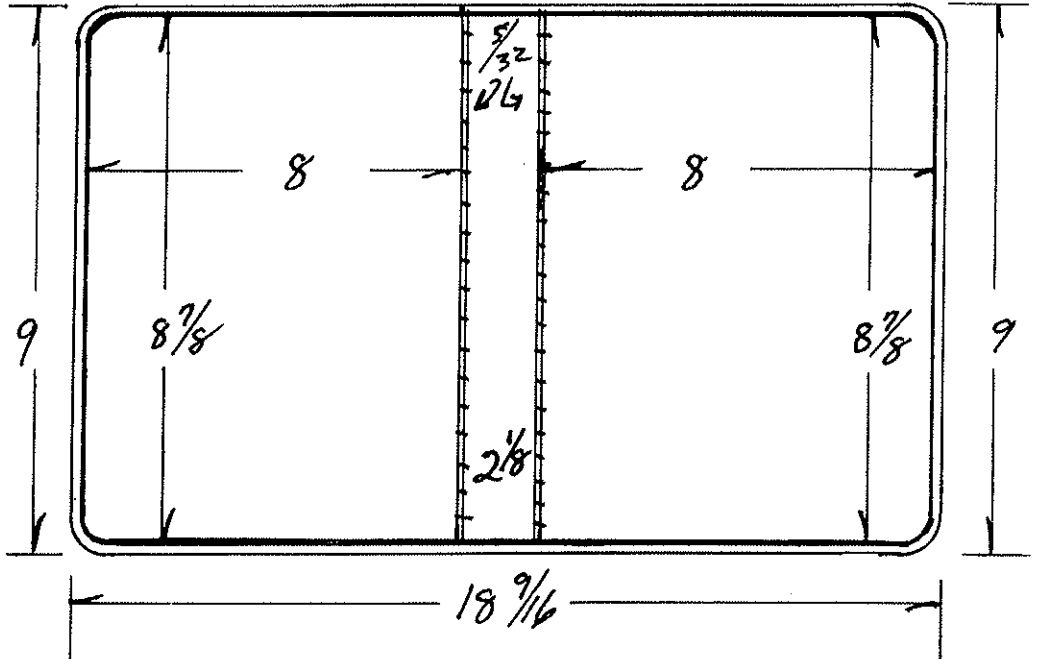

	Gauge	Thick
Tear Seal	.016	1PT.
Bar Seal	89 bis	4.M.M
Bar Seal		

	No. of Feet
Tear Seal	
Bar Seal	
Bar Seal	

Code	Ga.	# PCS	Cutting Specs		Code	Ga.	# Pcs.	Cutting Specs	
			Size	Out				Size	Out
Cover Mat.		1	9 5/8 X 19 5/16		Lining Mat.		1	9 5/8 X 19 5/16	
Cover Mat.			X		Lining Mat.			X	
Vert. Pckt.			X		Horz. Pckt.		1	9 1/16 X 10 13/16	
Vert. Pckt.			X		Horz. Pckt.			X	
Pocket			X		Pocket			X	
Label Holder			X		Card Holder			X	
Material			X		Material			X	
Material			X		Material			X	
Material			X		Material			X	
F.C. Board			8 25/32 X 7 29/32		B.C. Board		1	8 25/32 X 7 29/32	
B.C. Board			X		B.B. Board		1	8 25/32 X 2 1/32	
Center Board			X		Board			X	
Board			X		Strip			X	
Cover Pad			X		Strip			X	
					B.B. Pad			X	





Product Code

Style Case *Ring Binder* *Leonard*

Sheet Size  $8\frac{1}{2} \times 6\frac{5}{8}$  Cap. 1

Die No. 3856

Order No. 956306

Plate

Customer

Software of the Future

Metal
Total Vinyl .030
Quantity 1000
Date 8-19-87
Type Corners RJ
Radius 1/4
Completed

	Gauge	Thick
Tear Seal	.016	3/32
Bar Seal	178	3/16
Bar Seal		

	No. of Feet
Tear Seal	
Bar Seal	
Bar Seal	

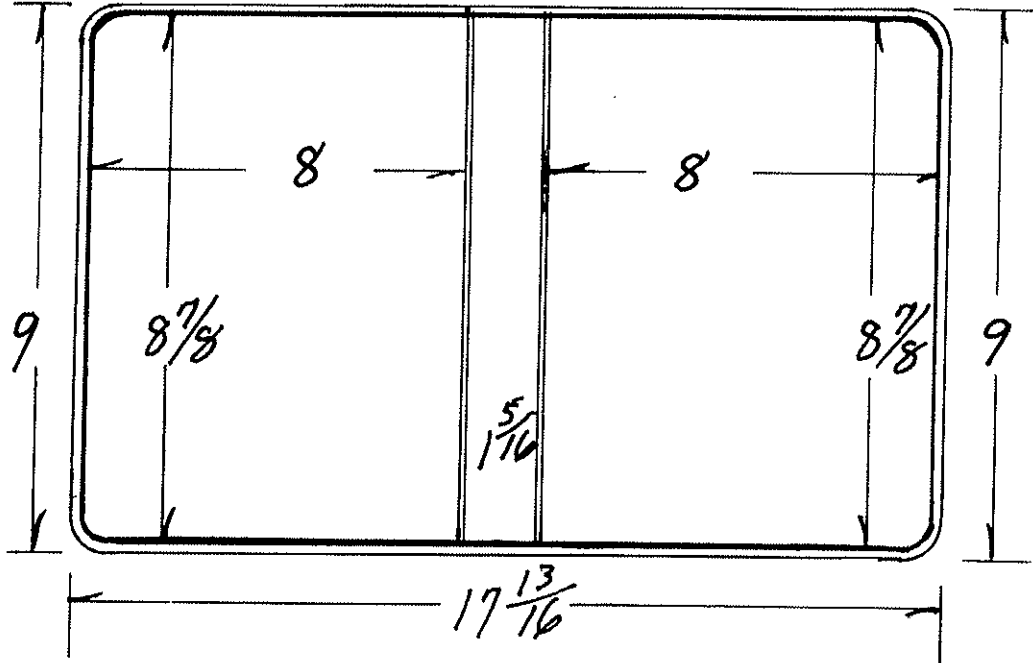

Code	Ga.	#	PCS	Cutting Specs		Code	Ga.	#	PCS	Cutting Specs	
				Size	Out					Size	Out
Cover Mat.			1	$9\frac{5}{8} \times 18\frac{9}{16}$		Lining Mat.			1	$9\frac{5}{8} \times 18\frac{9}{16}$	
Cover Mat.				X		Lining Mat.				X	
Vert. Pckt.				X		Horz. Pckt.				X	
Vert. Pckt.				X		Horz. Pckt.				X	
Pocket				X		Pocket			1	$5\frac{3}{8} \times 8\frac{9}{16}$	
Label Holder				X		Card Hlder				X	
Material				X		Material				X	
Material				X		Material				X	
Material				X		Material				X	
F.C. Board			1	$8\frac{25}{32} \times 7\frac{29}{32}$		B.C. Board			1	$8\frac{25}{32} \times 7\frac{29}{32}$	
B.C. Board				X		B.B. Board			1	$8\frac{25}{32} \times 1\frac{1}{32}$	
Center Board				X		Board				X	
Board				X		Strip				X	
Cover Pad				X		Strip				X	
						B.B. Pad				X	

Product Code

Style Case *D-Ring Binder* w/Bo

Sheet Size *8 1/2 X 6 1/2* Cap. *1* Die No. *3893* Order No. *10064* Plate

Customer

*Ring Binder supply*

Metal
Total Vinyl <i>.038</i>
Quantity <i>1</i>
Date <i>A.S.A.P</i>
Type Corners <i>Rd.</i>
Radius <i>3/8</i>
Completed

	Gauge	Thick
Tear Seal	<i>Knife</i>	<i>edge</i>
Bar Seal		<i>1/8</i>
Bar Seal		

	No. of Feet
Tear Seal	
Bar Seal	
Bar Seal	

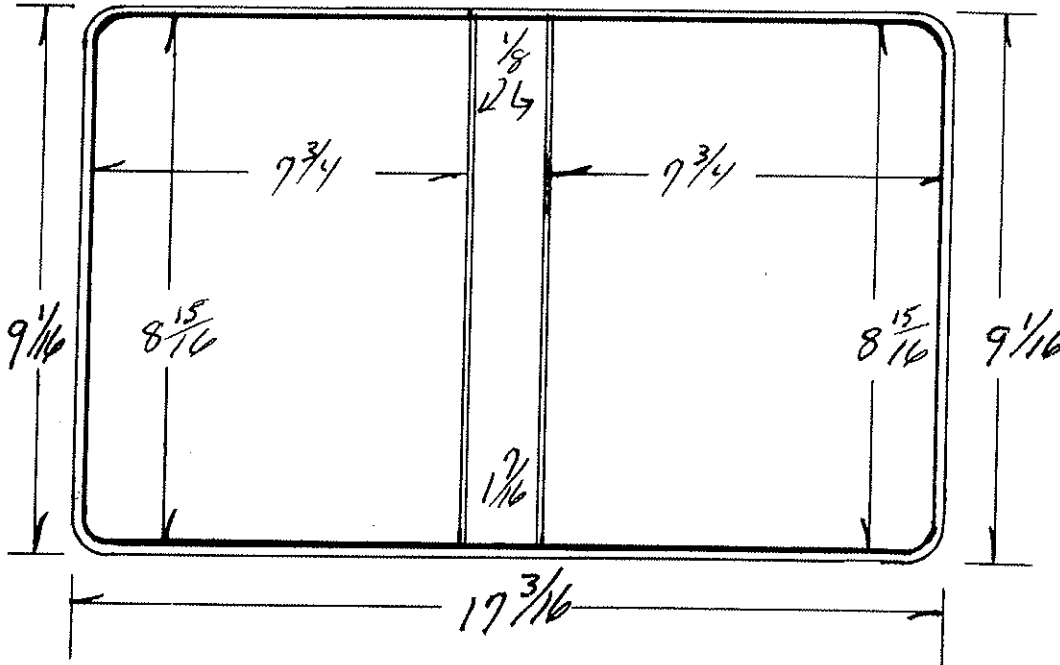

*Inside of Die is outside of Binder*  
*To be make by Able Die Co.*

Code	Ga.	#	PCS	Cutting Specs		Code	Ga.	#	PCS	Cutting Specs	
				Size	Out					Size	Out
Cover Mat.			<i>1</i>			Lining Mat.			<i>1</i>		
Cover Mat. <i>Clear</i>			<i>1</i>			Lining Mat.					
Vert. Pckt.						Horz. Pckt.					
Vert. Pckt.						Horz. Pckt.					
Pocket						Pocket					
Label Holder						Card Holder					
Material						Material					
Material						Material					
Material						Material					
F.C. Board			<i>1</i>			B.C. Board			<i>1</i>		
B.C. Board						B.B. Board			<i>1</i>		
Center Board						Board					
Board						Strip					
Cover Pad						Strip					
						B.B. Pad					

Product Code

Style Case *D-ring Binder* w/Board

Sheet Size  $8\frac{1}{2}$  X  $6\frac{1}{2}$

Cap.  $1\frac{1}{4}$

Die No. 3894

Order No. 100103

Plate

Customer

*Ring Binder Supply*

Metal
Total Vinyl <i>1.038</i>
Quantity <i>1</i>
Date <i>ASHP</i>
Type Corners <i>Rd</i>
Radius <i>3/8</i>
Completed

	Gauge	Thick
Tear Seal	<i>Knife</i>	<i>edge</i>
Bar Seal		<i>1/8</i>
Bar Seal		

	No. of Feet
Tear Seal	
Bar Seal	
Bar Seal	

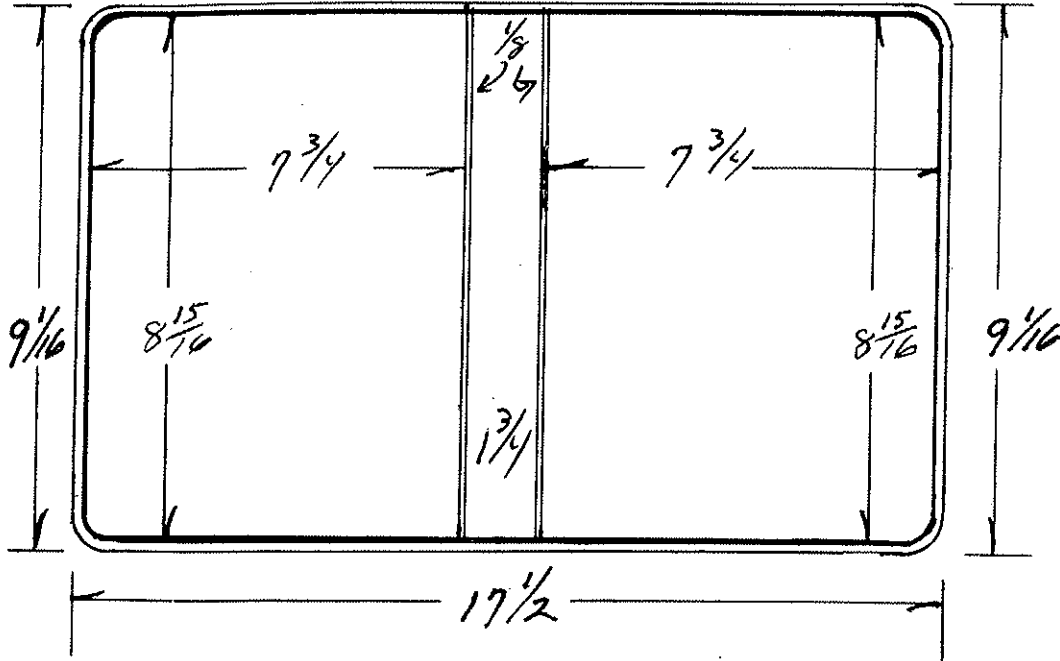

*Inside of Die is outside of Binder*

*Able Die Co. to Make Die*

Code		Cutting Specs				Code		Cutting Specs			
		Ga.	# PCS	Size	#			Ga.	# Pcs.	Size	#
Cover Mat.			1	$9\frac{1}{16}$ X $18\frac{5}{8}$		Lining Mat.			1	$9\frac{1}{16}$ X $18\frac{5}{8}$	
Cover Mat	<i>Clear</i>		1	$9\frac{1}{16}$ X $18\frac{5}{8}$		Lining Mat.		X			
Vert. Pckt.				X		Horz. Pckt.		X			
Vert. Pckt.				X		Horz. Pckt.		X			
Pocket				X		Pocket		X			
Label Hoker				X		Card Hlder		X			
Material				X		Material		X			
Material				X		Material		X			
Material				X		Material		X			
F.C. Board			120	$8\frac{27}{32}$ X $7\frac{21}{32}$	1	B.C. Board			120	$8\frac{27}{32}$ X $7\frac{21}{32}$	1
B.C. Board			100	$8\frac{7}{8}$ X $7\frac{11}{16}$	2	B.B. Board			120	$8\frac{27}{32}$ X $1\frac{21}{32}$	1
Center Board			100	$8\frac{7}{8}$ X $1\frac{21}{32}$	1	Board		X			
Board				X		Strip		X			
Cover Pad				X		Strip		X			
						B.B. Pad		X			



Product Code

Style Case leonard str. P.

Sheet Size 8 1/2 X 6 1/4 Cap. 1 Die No. 3960 Order No. 958107 Plate

Customer

Prime Computer, Inc.

Metal
Total Vinyl <u>1030</u>
Quantity <u>2250</u>
Date <u>2-19-88</u>
Type Corners <u>Rd</u>
Radius <u>1/4</u>
Completed

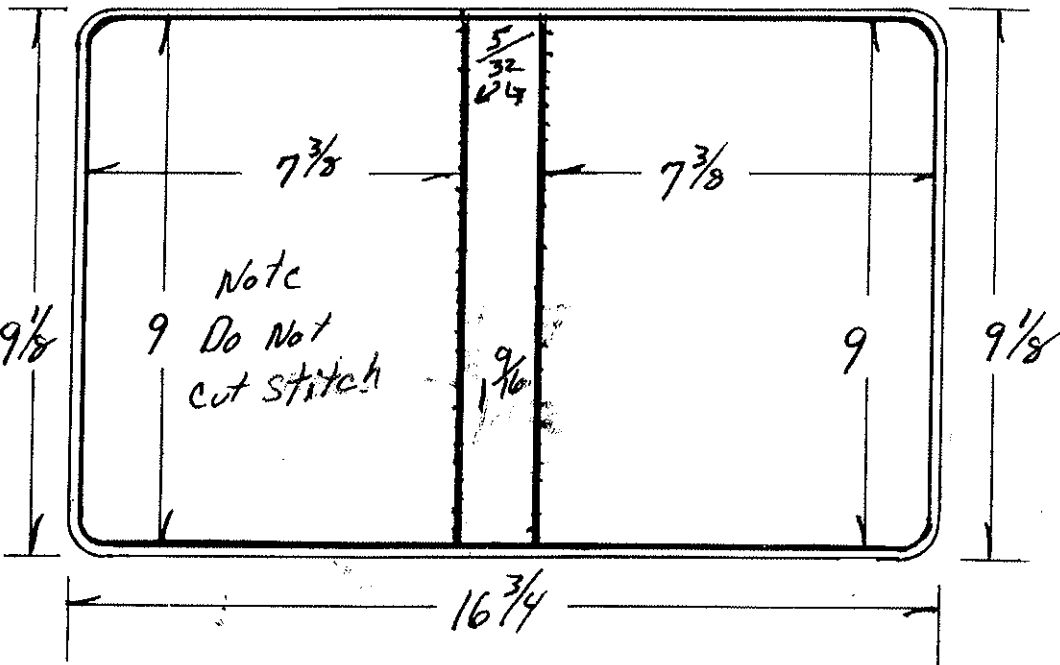

	Gauge	Thick
Tear Seal	<u>.016</u>	<u>101</u>
Bar Seal	<u>254</u>	<u>5/32</u>
Bar Seal		

	No. of Feet
Tear Seal	
Bar Seal	
Bar Seal	

Code	Ga.	# PCS	Cutting Specs		Code	Ga.	# Pcs.	Cutting Specs	
			Size	Out				Size	Out
Cover Mat.		<u>1</u>	<u>9 3/4 X 17 3/8</u>		Lining Mat.		<u>1</u>	<u>9 3/4 X 17 3/8</u>	
Cover Mat.			X		Lining Mat.			X	
Vert. Pckt.			X		Horz. Pckt.			X	
Vert. Pckt.			X		Horz. Pckt.			X	
Pocket			X		Pocket			X	
Label Holder			X		Card Holder			X	
Material			X		Material			X	
Material			X		Material			X	
Material			X		Material			X	
F.C. Board		<u>100</u>	<u>8 29/32 X 7 9/32</u>		B.C. Board		<u>100</u>	<u>8 29/32 X 7 9/32</u>	
B.G. Board		<u>100</u>	<u>8 15/16 X 7 5/16</u>		B.B. Board		<u>100</u>	<u>8 29/32 X 1 15/32</u>	
Center Board		<u>100</u>	<u>8 15/16 X 1 1/2</u>		Board			X	
Board			X		Strip			X	
Cover Pad			X		Strip			X	
Padded Board			<u>Die # 3960B</u>		B.B. Pad			X	
			<u>10 X 21 3/8</u>						



Product Code Everlast Rings

Style Case Lenord Angle D

Sheet Size 8 1/2 X 6 Cap. 1

Die No. 4057

Order No. 959759

Plate 100/800

Customer Rhodes Furniture

Metal
Total Vinyl
Quantity
Date
Type Corners <u>Rd</u>
Radius <u>1/4</u>
Completed

	Gauge	Thick
Tear Seal	<u>16</u>	<u>202</u>
Bar Seal	<u>250</u>	<u>1/2</u>
Bar Seal		

	No. of Feet
Tear Seal	
Bar Seal	
Bar Seal	

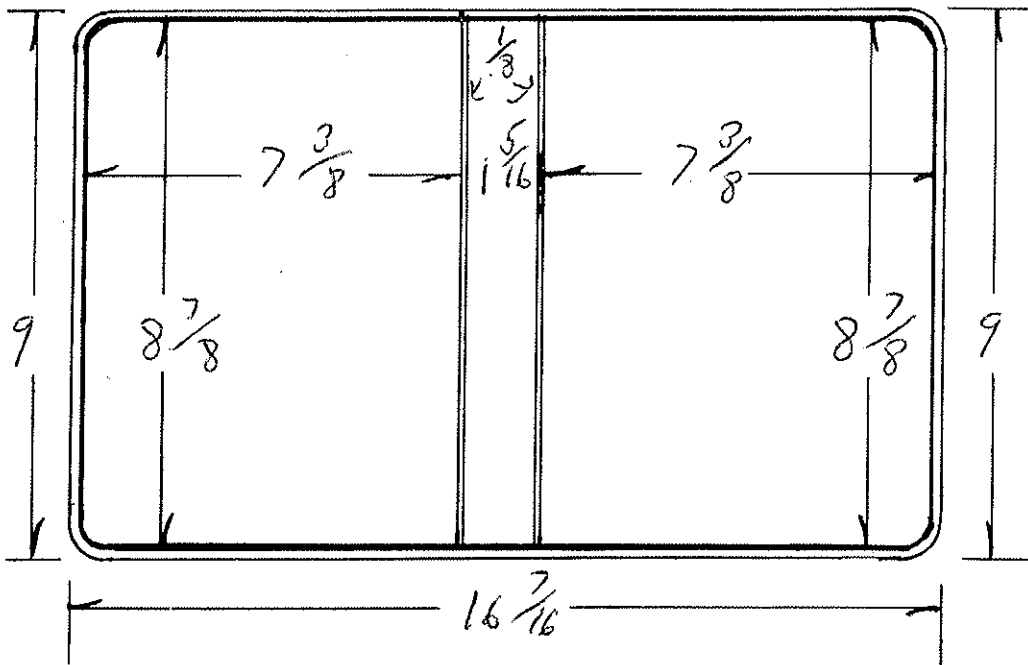

Code	Ga.	#	Cutting Specs		Code	Ga.	#	Cutting Specs			
			Size	Out				Size	Out		
Cover Mat.			<u>9 5/8 X 17 1/4</u>	<u>1</u>	Lining Mat.			<u>9 5/8 X 12 1/4</u>	<u>1</u>		
Cover Mat			X		Lining Mat.			X			
Vert. Pckt.			X		Horz. Pckt.			X			
Vert. Pckt.			X		Horz. Pckt.			X			
Pocket			X		Pocket			X			
Label Holder			X		Card Holder			X			
Material			X		Material			X			
Material			X		Material			X			
Material			X		Material			X			
F.C. Board			<u>8 25/32 X 7 9/32</u>	<u>100</u>	<u>1</u>	B.C. Board			<u>8 25/32 X 7 9/32</u>	<u>100</u>	<u>1</u>
B.C. Board			X		B.B. Board			<u>8 25/32 X 1 7/32</u>	<u>100</u>	<u>1</u>	
Center Board			<u>8 13/16 X 7 5/16</u>	<u>100</u>	<u>2</u>	Board			X		
Board			<u>8 13/16 X 1 7/32</u>	<u>100</u>	<u>1</u>	Strip			X		
Cover Pad			X		Strip			X			
					B.B. Pad			X			

Product Code

Style Case D-VRB w/ Beater

Sheet Size  $8\frac{1}{2} \times 6\frac{3}{8}$  Cap.  $1\frac{1}{2}$ " Die No. 4207

Order No. 962543 Plate

Customer INTERSTATE 2

Metal
Total Vinyl
Quantity
Date
Type Corners
Radius
Completed

	Gauge	Thick
Tear Seal	Ø	$\frac{1}{32}$ "
Bar Seal		$\frac{5}{32}$ R/B
Bar Seal		

	No. of Feet
Tear Seal	
Bar Seal	
Bar Seal	

USE CUTTING DIE # 4208

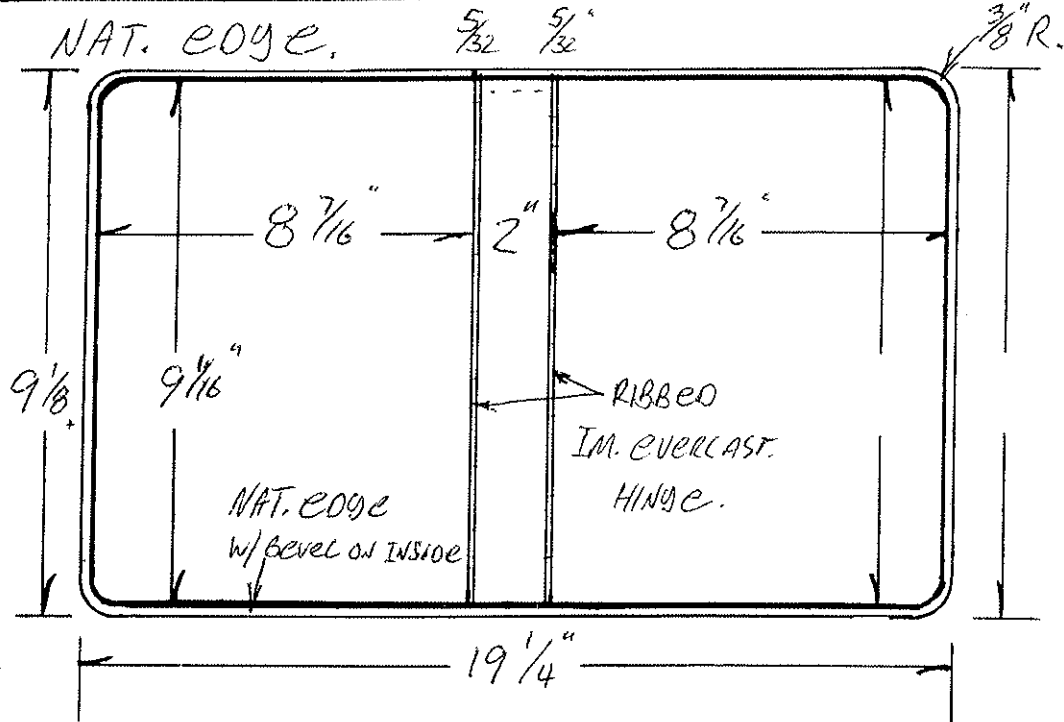

Code		Ga.	# PCS	Size	Cutting Specs	Code		Ga.	# Pcs.	Size	Cutting Specs
Cover Mat.	$9\frac{7}{8} \times 20"$	15	1			Lining Mat.	$9\frac{7}{8} \times 20"$	15	1		
Cover Mat.	X					Lining Mat.	X				
Vert. Pckt.	X					Horz. Pckt.	X				
Vert. Pckt.	X					Horz. Pckt.	X				
Pocket	X					Pocket	X				
Label Holder	X					Card Hlder	X				
Material	X					Material <i>die cut</i>	$11 \times 21$	8	1		
Material	X					Material	X				
Material	X					Material	X				
F.C. Board	$8\frac{3}{32} \times 8\frac{11}{32}$	100	1			B.C. Board	X				
B.C. Board	$8\frac{3}{32} \times 8\frac{11}{32}$	100	1			B.B. Board	$8\frac{3}{32} \times 1\frac{29}{32}$				
Center Board	X					Board	X				
Board	X					Strip	X				
Cover Pad	X					Strip	X				
						B.B. Pad	X				





Product Code

Style Case *SLANT D. VRB-LEON.*

Sheet Size *8 1/2 x 6* Cap. *2* Die No. *4255* Order No. *963282* Plate

Customer

*CONTINENTAL AIRLINES*

*MPH Edge / Detail*

Metal
Total Vinyl
Quantity <i>1,000</i>
Date <i>8-10-89</i>
Type Corners <i>NO</i>
Radius <i>3/8"</i>
Completed

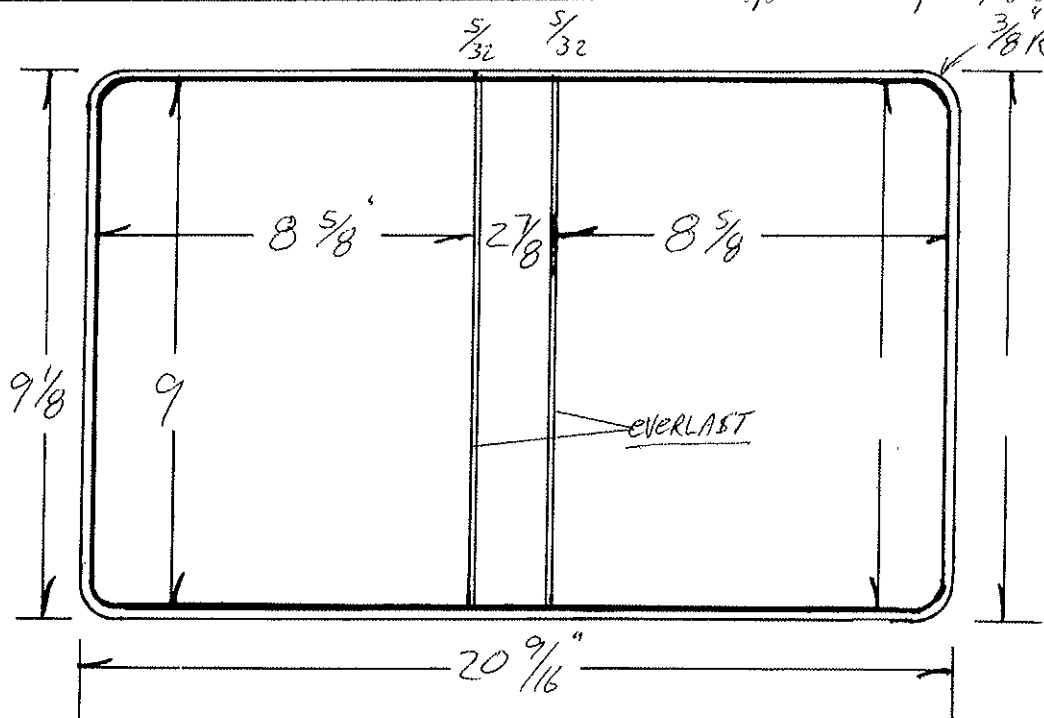

	Gauge	Thick
Tear Seal	<i>016</i>	<i>3/32</i>
Bar Seal	<i>#254</i>	<i>3/32</i>
Bar Seal		

	No. of Feet
Tear Seal	
Bar Seal	
Bar Seal	

*PER SAMPLE METAL*

*\* best cut comes from 9 7/8 so 3/4 was added*

Code		Ga. #		PCS		Cutting Specs		Code		Ga. #		PCS		Cutting Specs	
						Size	Out					Size	Out		
Cover Mat.	<i>*</i>	<i>9 7/8</i>	<i>X</i>	<i>21 3/16</i>	<i>15</i>	<i>1</i>		Lining Mat.		<i>9 7/8</i>	<i>X</i>	<i>21 3/16</i>	<i>15</i>	<i>1</i>	
Cover Mat			<i>X</i>					Lining Mat.			<i>X</i>				
Vert. Pckt.			<i>X</i>					Horz. Pckt.			<i>X</i>				
Vert. Pckt.			<i>X</i>					Horz. Pckt	<i>1 side</i>	<i>5 3/8</i>	<i>X</i>	<i>9 1/8</i>	<i>15</i>	<i>1</i>	
Pocket			<i>X</i>					Pocket			<i>X</i>				
Label Holder			<i>X</i>					Card Hlder			<i>X</i>				
Material			<i>X</i>					Material	<i>C.O.L.</i>	<i>9 1/4</i>	<i>X</i>	<i>21 3/8</i>	<i>8</i>	<i>1</i>	
Material			<i>X</i>					Material			<i>X</i>				
Material			<i>X</i>					Material			<i>X</i>				
F.C. Board		<i>8 29/32</i>	<i>X</i>	<i>8 17/32</i>	<i>120</i>	<i>1</i>		B.C. Board			<i>X</i>				
B.C. Board		<i>8 29/32</i>	<i>X</i>	<i>8 17/32</i>	<i>120</i>	<i>1</i>		B.B. Board		<i>8 29/32</i>	<i>X</i>	<i>2 25/32</i>	<i>120</i>	<i>1</i>	
Center Board		<i>8 15/16</i>	<i>X</i>	<i>8 9/16</i>	<i>120</i>	<i>2</i>		Board			<i>X</i>				
Board		<i>8 15/16</i>	<i>X</i>	<i>2 25/32</i>		<i>1</i>		Strip			<i>X</i>				
Cover Pad			<i>X</i>					Strip			<i>X</i>				
								B.B. Pad			<i>X</i>				

Product Code Journal NB Angle S 2 NB Style Case C.O.L. V.R.B. Wing

Sheet Size 8 1/2 x 6 Cap. 1 1/2 Die No. 4265 Order No. 963349 Plate

Customer CONTINENTAL EXPRESS AIRLINES

Metal
Total Vinyl
Quantity <u>300</u>
Date <u>8-21-69</u>
Type Corners <u>RIND</u>
Radius <u>3/8</u>
Completed

	Gauge	Thick
Tear Seal	<u>016</u>	<u>3/32</u>
Bar Seal	<u>#254</u>	<u>3/32</u>
Bar Seal		

	No. of Feet
Tear Seal	
Bar Seal	
Bar Seal	

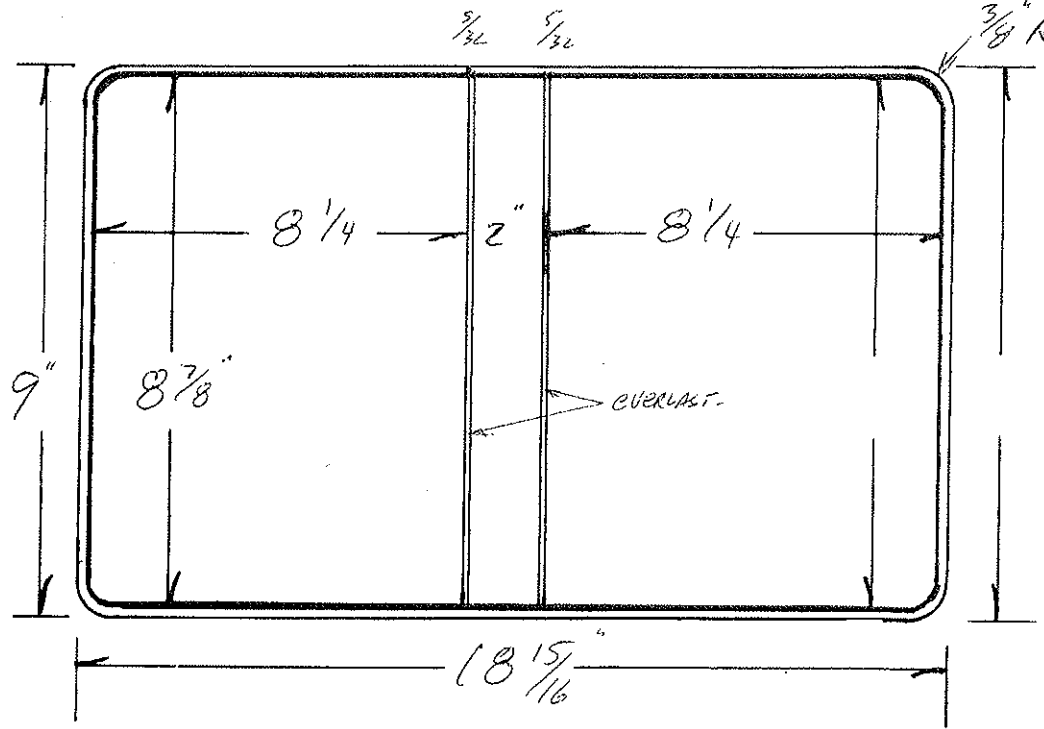

Code		Cutting Specs				Code		Cutting Specs			
		Ga.	# PCS	Size	#			Ga.	# Pcs.	Size	#
Cover Mat.	<u>9 3/4 X 19 3/4</u>	<u>15</u>	<u>1</u>			Lining Mat.	<u>9 3/4 X 19 3/4</u>	<u>15</u>	<u>1</u>		
Cover Mat	X					Lining Mat.	X				
Vert. Pckt.	X					Horz. Pckt.	<u>.5" 5 3/8 X 19 3/4</u>		<u>1</u>		
Vert. Pckt.	X					Horz. Pckt.	<u>5" 5 3/8 X 8 3/4</u>	<u>15</u>	<u>1</u>		
Pocket	X					Pocket	<u>4" 4 3/8 X 19 3/4</u>		<u>1</u>		
Label Holder	X					Card Holder	X				
Material	X					Material	<u>FULL C.O.L. 9 1/8 X 19 3/4</u>	<u>8</u>	<u>1</u>		
Material	X					Material	<u>EX C.O.L. 9 1/8 X 11 1/2</u>	<u>8</u>	<u>1</u>		
Material	X					Material	X				
F.C. Board	<u>8 25/32 X 8 5/32</u>	<u>100</u>	<u>1</u>			B.C. Board	X				
B.C. Board	<u>8 25/32 X 8 5/32</u>	<u>100</u>	<u>1</u>			B.B. Board	<u>8 25/32 X 1 29/32</u>	<u>100</u>	<u>1</u>		
Center Board	<u>8 13/16 X 8 3/16</u>	<u>100</u>	<u>2</u>			Board	X				
Board	<u>8 13/16 X 1 29/32</u>	<u>100</u>	<u>1</u>			Strip	X				
Cover Pad	X					Strip	X				
						B.B. Pad	X				

Product Code

Steward  
Style Case A.D. VRR

Sheet Size  $8\frac{1}{2} \times 6\frac{7}{8}$  Cap.  $1\frac{1}{2}$  Die No. 4341 Order No. 964335 Plate

Customer

CHASE ACCESS SERVICES

Metal
Total Vinyl
Quantity 250
Date 12-13-89
Type Corners
Radius $\frac{3}{8}$ "
Completed

	Gauge	Thick
Tear Seal	.016	$\frac{1}{16}$
Bar Seal	EVERLAST	$\frac{3}{32} +$
Bar Seal		

	No. of Feet
Tear Seal	
Bar Seal	
Bar Seal	

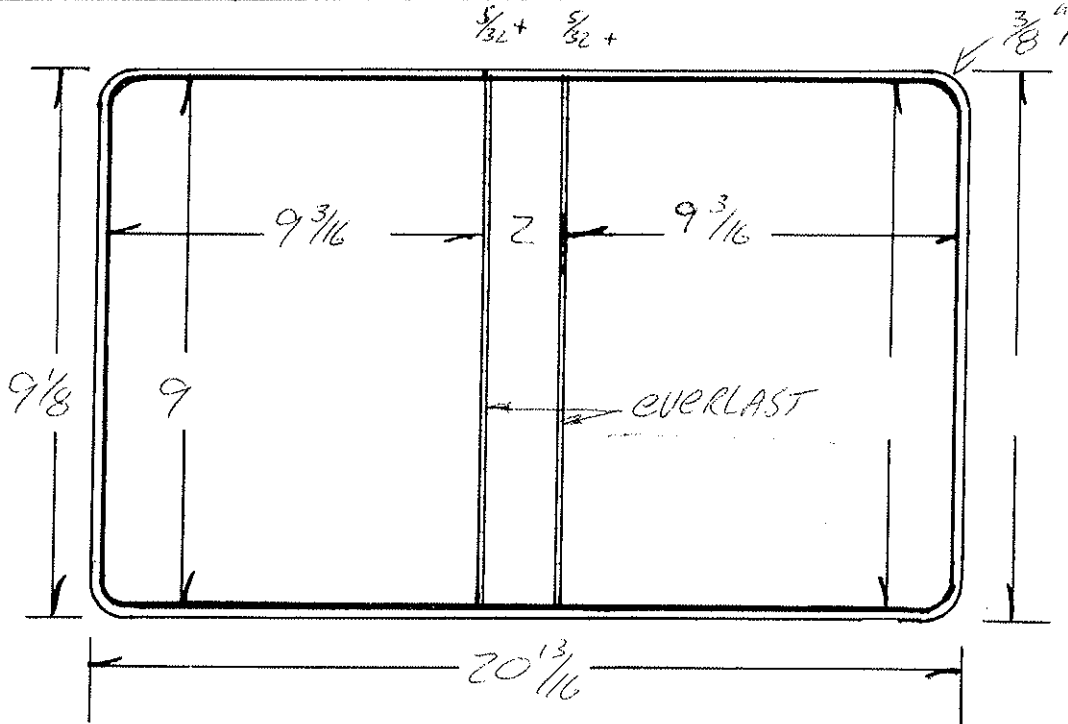

BY-12-18-89

SIZES BY: B.P.

CHECK BY:

*(Handwritten signature/initials)*

Code		Cutting Specs		Code		Cutting Specs	
Ga.	# PCS	Size	Out	Ga.	# PCS	Size	Out
Cover Mat.	10	X	$21\frac{5}{8}$	15	1	Lining Mat.	10 X $21\frac{5}{8}$ 15 1
Cover Mat.		X		Lining Mat.		X	
Vert. Pckt.		X		Horz. Pckt.		X	
Vert. Rckt.		X		Horz. Pckt.		X	
Pocket		X		Pocket		X	
Label Holder		X		Card Hlder		X	
Material		X		Material	$9\frac{1}{4} \times 21\frac{5}{8}$	8	1
Material		X		Material		X	
Material		X		Material		X	
F.C. Board	$8\frac{29}{32}$	X	$9\frac{3}{32}$	B.C. Board		X	
B.C. Board	$8\frac{29}{32}$	X	$9\frac{3}{32}$	B.B. Board	$8\frac{29}{32}$	X	$12\frac{9}{32}$ 100 1
Center Board		X		Board		X	
Board	$8\frac{15}{16}$	X	$9\frac{1}{8}$	Strip		X	
Cover Pad	$8\frac{15}{16}$	X	$12\frac{9}{32}$	Strip		X	
				B.B. Pad		X	

Product Code

Style Case STR. D. VRB

Sheet Size 8 1/2 x 7 1/4 Cap. 1 1/2-D Die No. 4368

Order No. 59182 Plate

Customer

NSC - TUSSEY COMPUTER PRODUCTS

Metal
Total Vinyl
Quantity <u>500</u>
Date <u>1-22-90</u>
Type Corners
Radius <u>3/8"</u>
Completed

	Gauge	Thick
Tear Seal	<u>.014</u>	<u>1/16</u>
Bar Seal	<u>.4253</u>	<u>1/8"</u>
Bar Seal		

	No. of Feet
Tear Seal	
Bar Seal	
Bar Seal	

Size - B.P.

Check - [Signature]

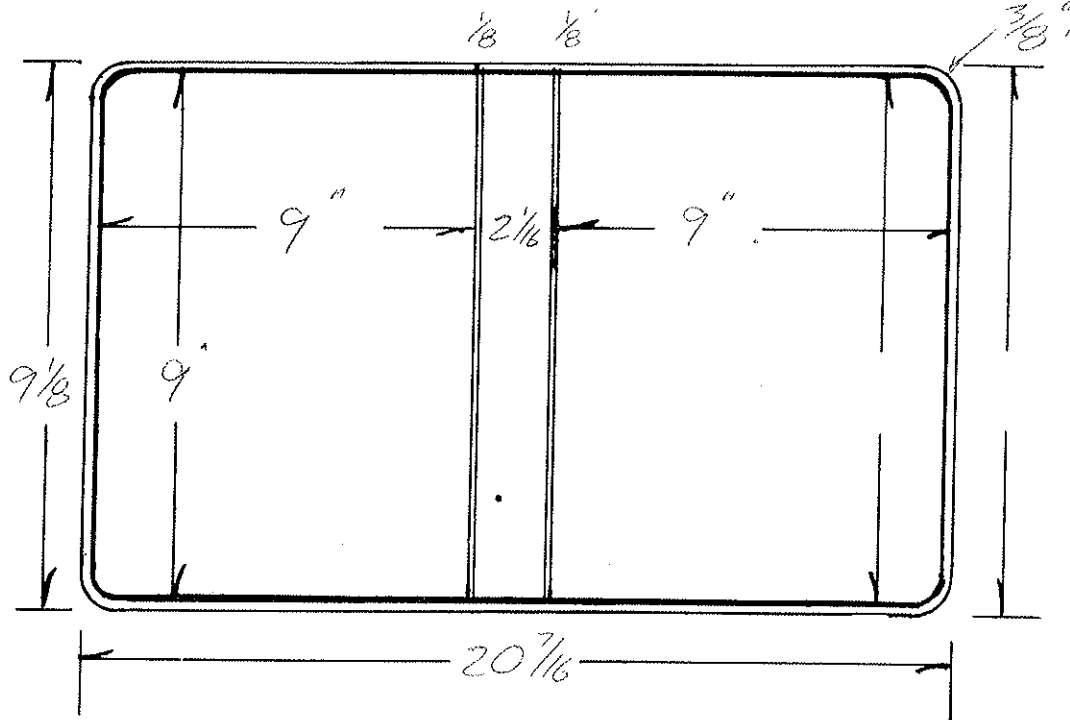

1-24

Code	Ga.	# PCS	Cutting Specs		Code	Ga.	# Pcs.	Cutting Specs			
			Size	Out				Size	Out		
Cover Mat. <u>S-0245</u>			$9 \frac{3}{4} \times 21 \frac{1}{4}$	15	1	Lining Mat. <u>S-0245</u>			$9 \frac{3}{4} \times 21 \frac{1}{4}$	15	1
Cover Mat.			X		Lining Mat.			X			
Vert. Pckt.			X		Horz. Pckt.			X			
Vert. Pckt.			X		Horz. Pckt.			X			
Pocket			X		Pocket			X			
Label Holder			X		Card Holder			X			
Material			X		Material <u>C.O.L.</u>			$9 \frac{1}{4} \times 21 \frac{1}{4}$	8	1	
Material			X		Material			X			
Material			X		Material			X			
F.C. Board			$8 \frac{29}{32} \times 8 \frac{29}{32}$	120	1	B.C. Board			X		
B.C. Board			$8 \frac{29}{32} \times 8 \frac{29}{32}$	100	1	B.B. Board			$8 \frac{29}{32} \times 1 \frac{31}{32}$	100	1
Center Board			$8 \frac{15}{16} \times 8 \frac{15}{16}$	100	2	Board			X		
Board			$8 \frac{15}{16} \times 1 \frac{31}{32}$	100	1	Strip			X		
Cover Pad			X		Strip			X			
					B.B. Pad			X			

Product Code

Style Case STR. 0-VRB. (LAWAN)

Sheet Size 8 1/2 X 6 1/2

Cap. 2-

Die No. 4384

Order No. 964817

Plate

Customer

SINAI SAMARITAN

Metal
Total Vinyl
Quantity 2000
Date 2-19-90
Type Corners
Radius 3/8
Completed

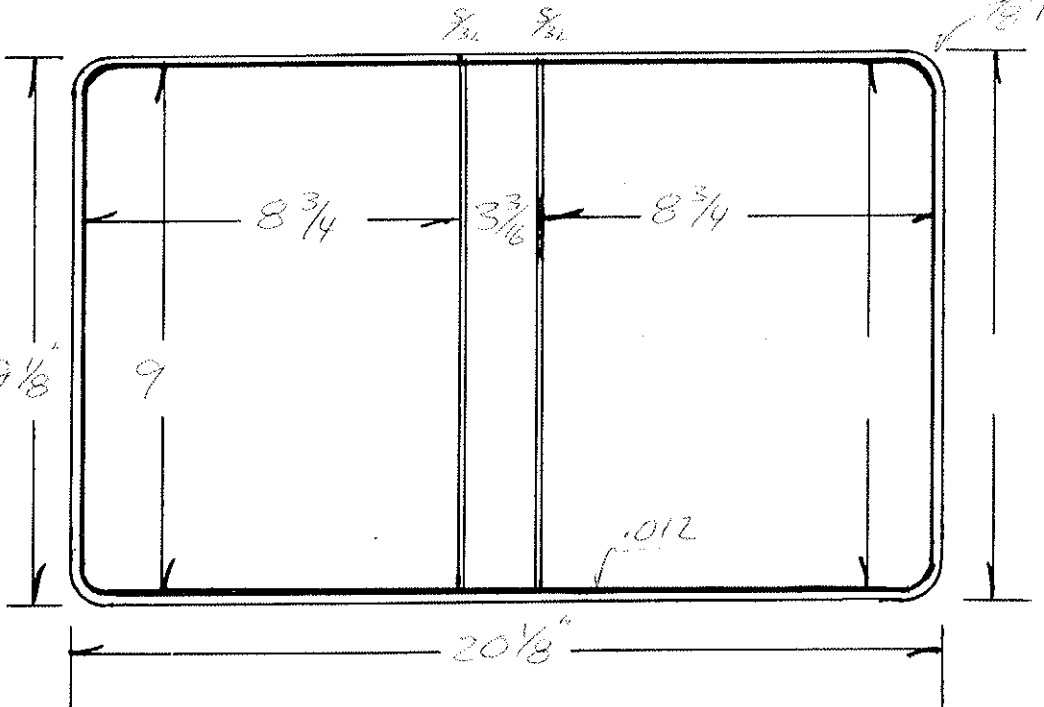

Gauge	Thick
Tear Seal .012	1/16
Bar Seal .0254	3/16
Bar Seal	

No. of Feet
Tear Seal
Bar Seal
Bar Seal

Size - Place  
 Label - *KPV*

Code	Ga.	# PCS	Cutting Specs		Code	Ga.	# Pcs.	Cutting Specs	
			Size	Out				Size	Out
Cover Mat.		9 3/4 X 20 7/8	12	1	Lining Mat.		9 3/4 X 20 7/8	12	1
Cover Mat		X			Lining Mat.		X		
Vert. Pckt.		X			Horz. Pckt.		X		
Vert. Pckt.		X			Horz. Pckt.		4 3/8 X 9 1/4	12	1
Pocket		X			Pocket		X		
Label Holder		X			Card Holder		X		
Material		X			Material	COL	9 1/4 X 20 7/8	8	1
Material		X			Material		X		
Material		X			Material		X		
F.C. Board		8 3/16 X 8 3/16	100	1	B.C. Board		X		
B.C. Board		8 3/16 X 8 3/16	100	1	B.B. Board		8 3/16 X 3 3/16	100	1
Center Board		X			Board		X		
Board		X			Strip		X		
Cover Pad		X			Strip		X		
					B.B. Pad		X		

Product Code

Style Case *STR. D. VRB N.R. (B...*

Sheet Size *8 1/2 x 7 1/4* Cap. *2*

Die No. *4389*

Order No. *964981*

Plate

Customer

*J.L. PRINTING - JOHNSON PUBLISHING*

Metal
Total Vinyl
Quantity <i>300</i>
Date <i>3-7-90</i>
Type Corners
Radius <i>3/16</i>
Completed

Gauge	Thick
Tear Seal <i>214</i>	<i>1/16</i>
Bar Seal <i>7374</i>	<i>7/16</i>
Bar Seal	

No. of Feet
Tear Seal
Bar Seal
Bar Seal

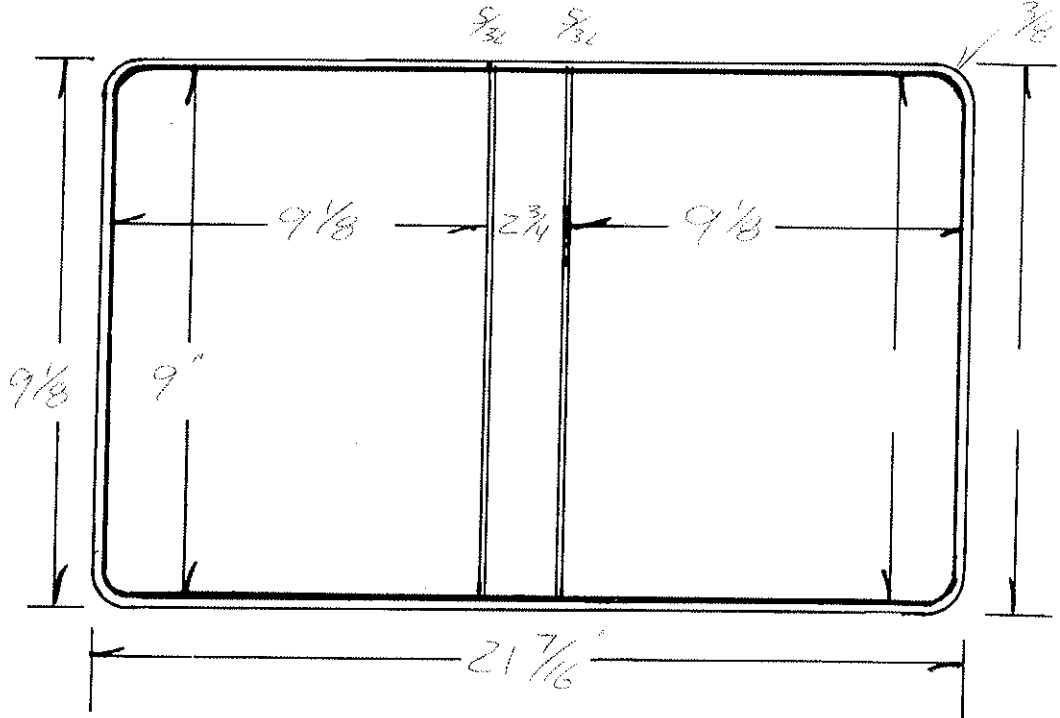

*Size - Reference*  
*Cross - 1/4"*

Code	Ga.	# PCS	Cutting Specs		Code	Ga.	# Pcs.	Cutting Specs	
			Size	Out				Size	Out
Cover Mat.			<i>9 3/4</i>	<i>x 22 1/4</i>	Lining Mat.			<i>9 3/4</i>	<i>x 22 1/4</i>
Cover Mat.			X		Lining Mat.			X	
Vert. Pckt.			X		Horz. Pckt.			X	
Vert. Pckt.			X		Horz. Pckt.			X	
Pocket			X		Pocket			X	
Label Holder			X		Card Holder			X	
Material			X		Material			X	
Material			X		Material			X	
Material			X		Material			X	
F.C. Board			<i>8 3/16</i>	<i>x 9 1/2</i>	B.C. Board			X	
B.C. Board			<i>8 3/16</i>	<i>x 9 1/2</i>	B.B. Board			<i>8 3/16</i>	<i>x 2 3/16</i>
Center Board			X		Board			X	
Board			<i>8 15/16</i>	<i>x 9 1/16</i>	Strip			X	
Cover Pad			<i>8 15/16</i>	<i>x 22 1/32</i>	Strip			X	
					B.B. Pad			X	

DIE #	4467	CAP.	1 1/2	METAL	STR. D VRB
STYLE CASE	VINYL RING BINDER			LOCATION	
SHEET SIZE	8 1/2 X 6 5/8		ORDER # 965935		
CUSTOMER	DATA GENERAL			DUE DATE	
QUANTITY		RADIUS	3/8		TEAR SEAL
DATE	1-5-95	COMPLETED		BAR SEAL	

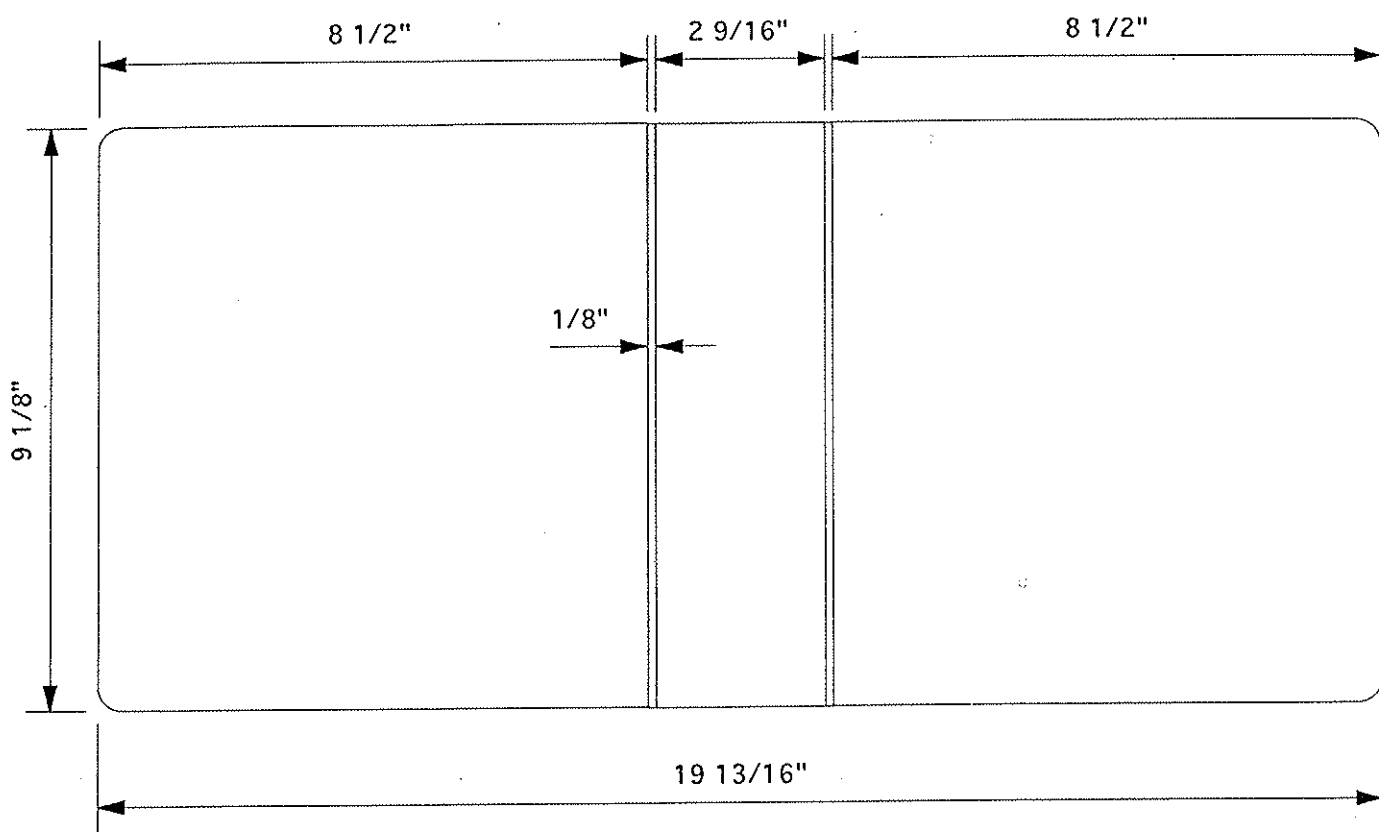

MATERIAL SPECS		GA	PCS			GA	PCS
COVER MAT.	9 3/4 X 20 5/8		1	LINING MAT	9 3/4 X 20 5/8		1
COVER MAT.				LINING MAT			
VERT PKT				HORZ PKT	5 3/8 X 20 5/8		1
CARD HOLDER				GUSSET			
COL				DIAGONAL PKT			
LABEL HOLDER				REINF			
BOARD SPECS		GA	PCS			GA	PCS
F.C. BOARD	9 X 8 11/32	100	1	F.C. BOARD			
B.B. BOARD	9 X 2 15/32	100	1	B.B. BOARD			
B.C. BOARD	9 X 8 11/32	100	1	B.C. BOARD			
B.U. STRIP							



Product Code

REPLACES 3701

Style Case STR. D. VRB

Sheet Size 8 1/2 x 6 1/2

Cap. 1-D

Die No. 4480

Order No.

Plate

Customer

ED. REVIEW / PC MASS

Metal
Total Vinyl
Quantity
Date 7-18-90
Type Corners
Radius 3/8
Completed

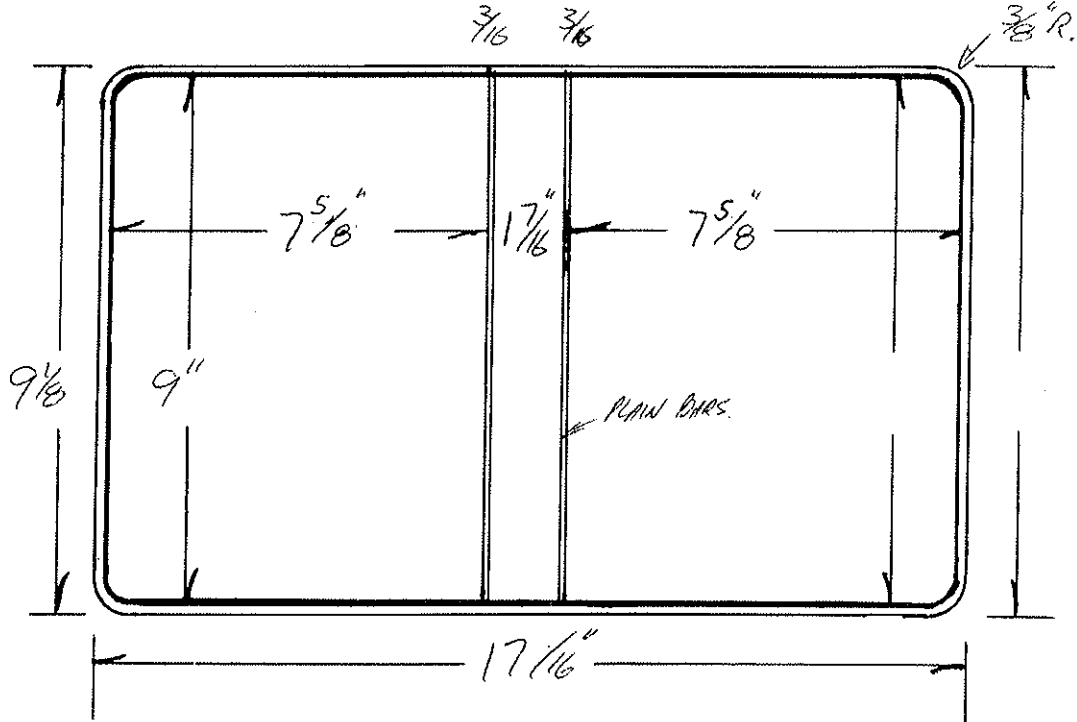

	Gauge	Thick
Tear Seal	214	1/16
Bar Seal	4178	7/16
Bar Seal		

	No. of Feet
Tear Seal	
Bar Seal	
Bar Seal	

SIZE - B. P. M.

CHECK - JAP V

PICTORIAL INSERT SIZES

8 7/8 x 7 3/8 - PANELS

8 7/8 x 1 1/32 - B.B.

Code	Ga.	# PCS	Cutting Specs		Code	Ga.	# Pcs.	Cutting Specs	
			Size	Out				Size	Out
Cover Mat.		15	9 3/4 X 18		Lining Mat.		15	9 3/4 X 18	
Cover Mat.			X		Lining Mat.			X	
Vert. Pckt.			X		Horz. Pckt. 1-5102		15	4 3/8 X 8 1/8	1
Vert. Pckt.			X		Horz. Pckt.			X	
Pocket			X		Pocket			X	
Label Holder			X		Card Holder			X	
Material			X		Material			X	
Material			X		Material			X	
Material			X		Material			X	
F.C. Board		120	8 29/32 X 7 17/32	1	B.C. Board			X	
B.G. Board		120	8 29/32 X 7 17/32	1	B.B. Board		120	8 29/32 X 13/8	1
Center Board			X		Board			X	
Board			X		Strip			X	
Cover Pad			X		Strip			X	
					B.B. Pad			X	

Product Code

Style Case *Straight D*

Sheet Size  $8\frac{1}{2} \times 6$  Cap.  $1\frac{1}{2}$  Die No. *4520* Order No. *966491.1* Plate

Customer

*LOGISTIX*

Metal
Total Vinyl
Quantity <i>1000</i>
Date <i>8-29-90</i>
Type Corners
Radius <i>3/16</i>
Completed

	Gauge	Thick
Tear Seal	<i>.012</i>	<i>1/16"</i>
Bar Seal	<i>#253</i>	<i>1/8"</i>
Bar Seal		

	No. of Feet
Tear Seal	
Bar Seal	
Bar Seal	

*DWS by KP*  
*Spec by KP*  
*✓ by B.P.*

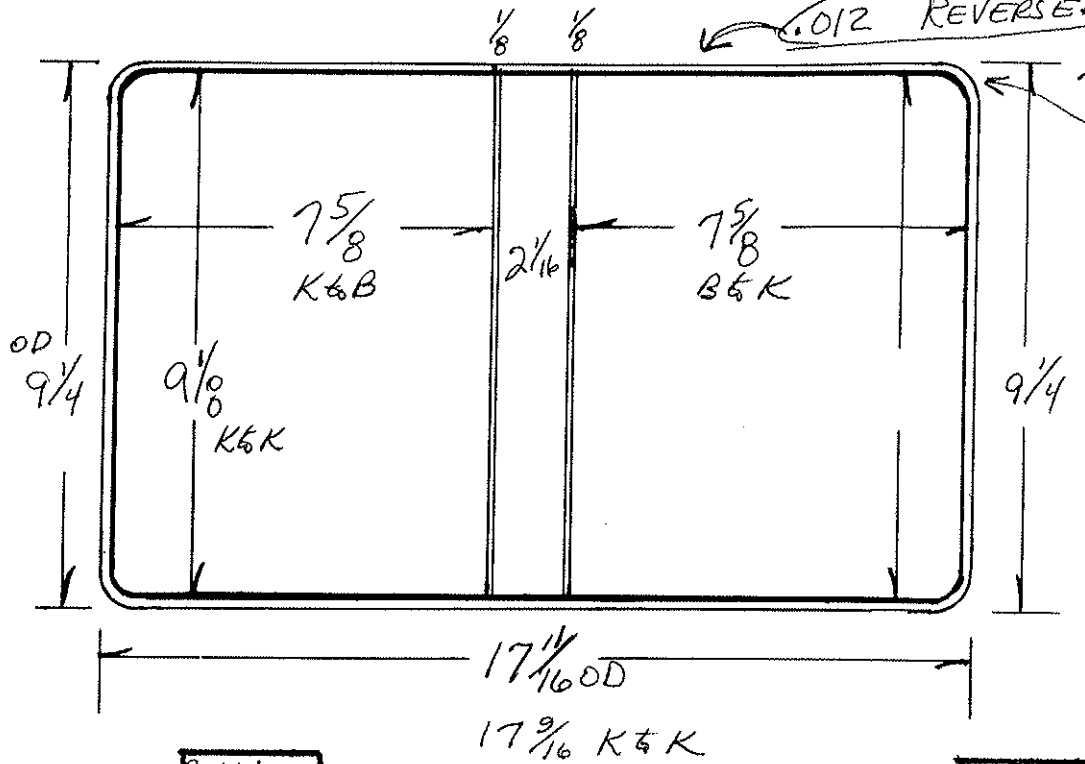

Code		Ga.	# PCS	Size	Out	Cutting Specs	Code		Ga.	# Pcs.	Size	Out	Cutting Specs	
Cover Mat.				<i>10 X 18 3/16</i>	<i>12</i>	<i>1</i>		Lining Mat.			<i>10 X 18 3/16</i>	<i>12</i>	<i>1</i>	
Cover Mat				X				Lining Mat.			X			
Vert. Pckt.				X				Horz. Pckt.			X			
Vert. Pckt.				X				Horz. Pckt.			X			
Pocket				X				Pocket			X			
Label Holder				X				Card Holder			X			
Material				X				Material			X			
Material				X				Material			X			
Material				X				Material			X			
F.C. Board				<i>9 X 7 1/2</i>	<i>100</i>	<i>1</i>		B.C. Board			X			
B.C. Board				<i>9 X 7 1/2</i>	<i>100</i>	<i>1</i>		B.B. Board			<i>9 X 1 3/32</i>	<i>100</i>	<i>1</i>	
Center Board				X				Board			X			
Board				X				Strip			X			
Cover Pad				X				Strip			X			
								B.B. Pad			X			

Product Code

Kolomon Hawley STR.D. ND CO-210-500  
Style Case STR.D. VRB (BENSON) 1)

Sheet Size  $8\frac{1}{2}$  x 6 Cap. 2"D Die No. 4610 Order No. 967169 Plate

Customer

CNG PRODUCING CO.

Metal
Total Vinyl
Quantity 50
Date 12-10-90
Type Corners
Radius $3/8"$
Completed

	Gauge	Thick
Tear Seal	1014	$1/16"$
Bar Seal		
Bar Seal		

	No. of Feet
Tear Seal	
Bar Seal	
Bar Seal	

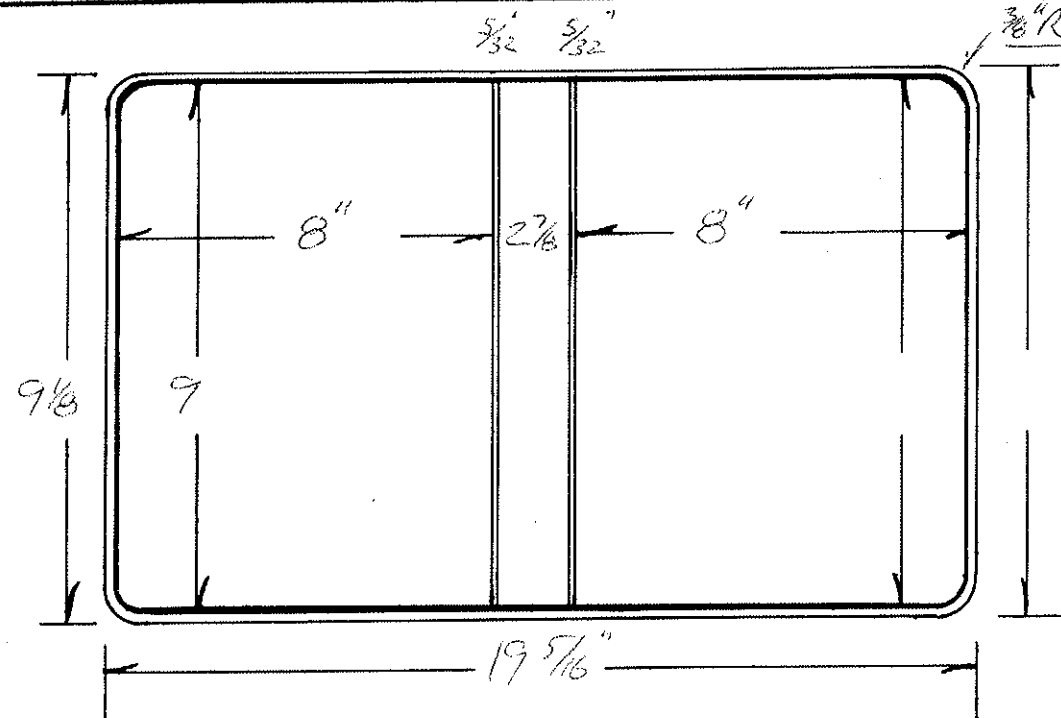

SIZE - B.P.  
CHECK - *(Signature)*

Code	Ga.	# PCS	Cutting Specs		Code	Ga.	# Pcs.	Cutting Specs	
			Size	Out				Size	Out
Cover Mat.		15	1		Lining Mat.	15	1		
Cover Mat.					Lining Mat.				
Vert. Pckt.					Horz. Pckt.				
Vert. Rckt.					Horz. Pckt.				
Pocket					Pocket				
Label Holder					Card Hlder				
Material					Material				
Material					Material				
Material					Material				
F.C. Board		100	1		B.C. Board				
B.G. Board		100	1		B.B. Board				
Center Board					Board				
Board	FC BC	100	2		Strip				
Cover Pad	BB	100	1		Strip				
					B.B. Pad				

Product Code

Stock: St. D. N.B.  
Style Case

Sheet Size 8 1/2 X 6 Cap. 1 1/2 D Die No. 4763 Order No. 968777 Plate C-14-7

Customer	INTERGRAPH CORP. (FIAB Die 7885)	
Metal		
Total Vinyl		
Quantity	500	
Date	5-15-91	
Type Corners		
Radius	3/8"	
Completed		

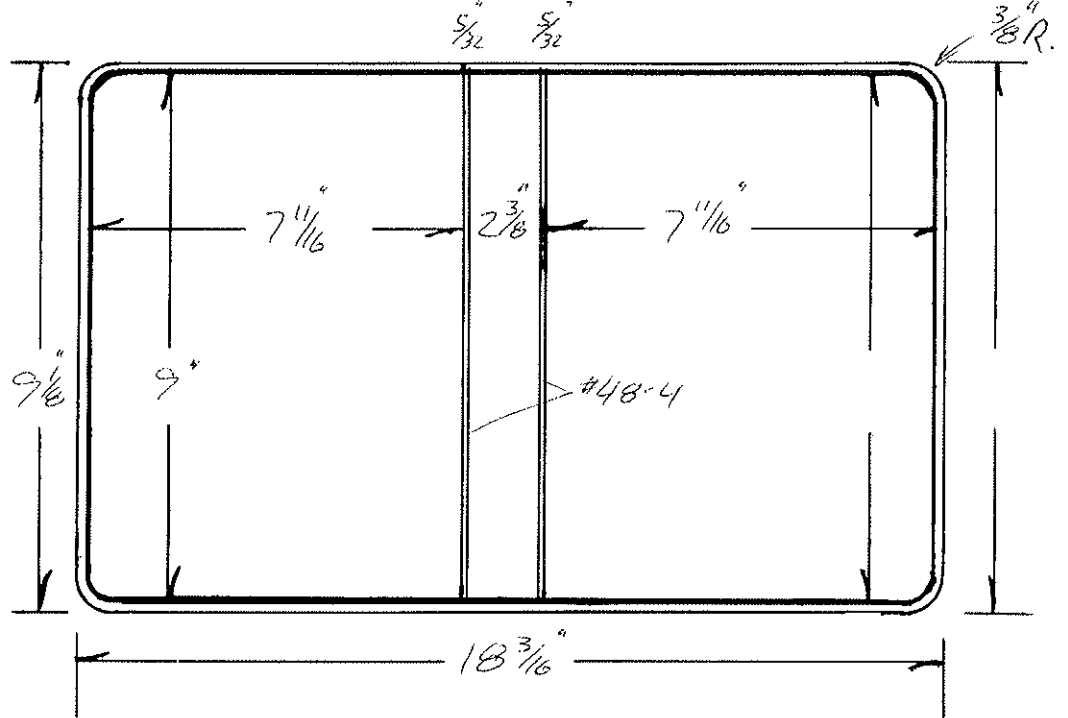

	Gauge	Thick
Tear Seal	.014	1/16
Bar Seal	#48-4	5/32
Bar Seal		

	No. of Feet
Tear Seal	
Bar Seal	
Bar Seal	

Order: B. Price  
Check

Code	Per metal	Cutting Specs				Code	Per metal	Cutting Specs			
		Ga.	#	Size	Out			Ga.	#	Size	Out
Cover Mat.	9 3/4 X 19	14	1			Lining Mat.	9 3/4 X 19	14	1		
Cover Mat.	X					Lining Mat.	X				
Vert. Pckt.	X					Horz. Pckt.	4 3/8 X 8 1/4				
Vert. Pckt.	X					Horz. Pckt.	4 3/8 X 19				
Pocket	X					Pocket	X				
Label Holder	X	8	1			Card Holder	X				
Material	X					Material	X				
Material	X					Material	X				
Material	X					Material	X				
F.C. Board	8 29/32 X 7 19/32	100	1			B.C. Board	X				
B.C. Board	8 29/32 X 7 19/32	100	1			B.B. Board	8 29/32 X 2 9/32	100	1		
Center Board	8 15/16 X 7 5/8	100	2			Board	8 15/16 X 2 9/32	100	1		
Board	X					Strip	X				
Cover Pad	X					Strip	X				
						B.B. Pad	X				

Product Code

Stock Style Case **STD NB**

Sheet Size **8 1/2 X 6** Cap. **2" 0** Die No. **4764** Order No. **968779** Plate **C-14-8**

Customer

**INTERGRAPH CORP.**

Metal
Total Vinyl
Quantity <b>500</b>
Date <b>5-15-91</b>
Type Corners
Radius <b>3/8</b>
Completed

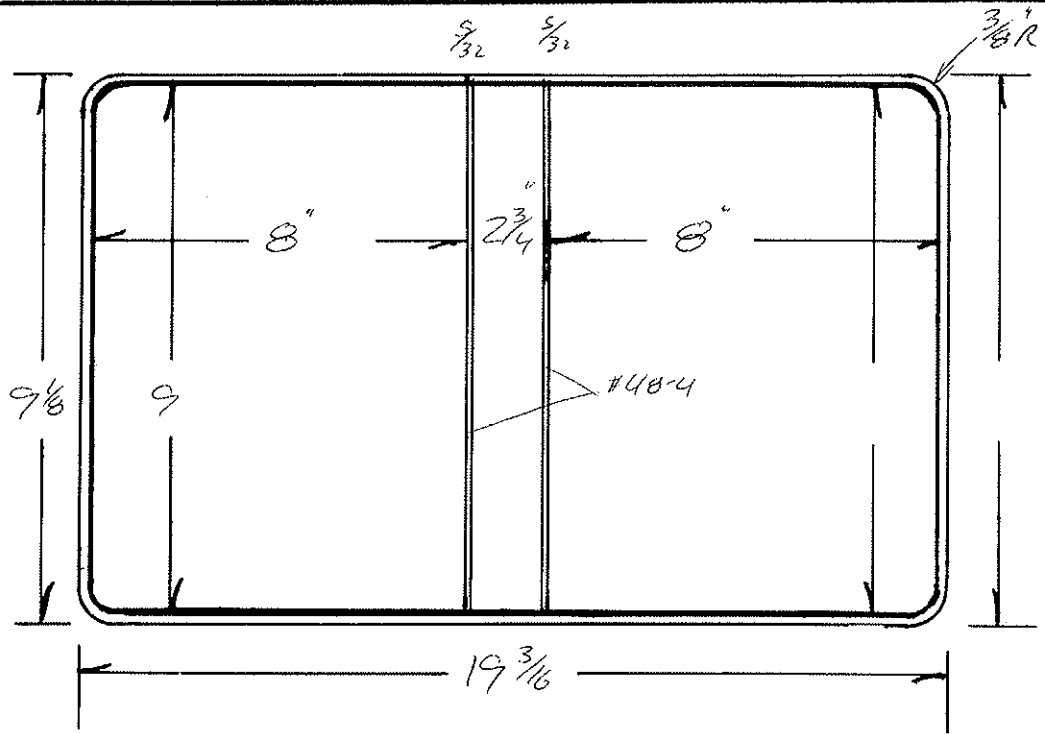

	Gauge	Thick
Tear Seal	.014	1/16
Bar Seal	#48-4	5/16
Bar Seal		

	No. of Feet
Tear Seal	
Bar Seal	
Bar Seal	

Dwg. B. Price  
Cwell. *[Signature]*

Code	PER METAL	Cutting Specs				Code	Cutting Specs			
		Ga.	# PCS	Size	Out		Ga.	# Pcs.	Size	Out
Cover Mat.		9 3/4	1	20"		Lining Mat.	9 3/4	1	20"	
Cover Mat.	X					Lining Mat.	X			
Vert. Pckt.	X					Horz. Pckt.	X			
Vert. Pckt.	X					Horz. Pckt.	4 3/8 X 20			
Pocket	X					Pocket	X			
Label Holder	X	8	1			Card Holder	X			
Material	X					Material	X			
Material	X					Material	X			
Material	X					Material	X			
F.C. Board		8 29/32	1	7 29/32	120	B.C. Board	X			
B.C. Board		8 29/32	1	7 29/32	100	B.B. Board	8 29/32 X 7 29/32	100	1	
Center Board	X					Board	X			
Board	X					Strip	X			
Cover Pad	X					Strip	X			
						B.B. Pad	X			

Product Code

Style Case STR. O. VRB BENSON

Sheet Size 8 1/2 X 6 5/8 Cap. 3/4 STD Die No. 4865

Order No. 969867

Plate C-18-6

JAMS SOFTWARE

9-4

Customer	
Material	BENSON 0210-3-20-SP
Total Vinyl	
Quantity	2500
Date	8-27-91
Type Corners	
Radius	3/8
Completed	

	Gauge	Thick
Ear Seal	.014	1/16
Ear Seal	48-4	3/32
Ear Seal		

	No. of Feet
Ear Seal	
Ear Seal	
Ear Seal	

WWS - B. Pace  
 KPD

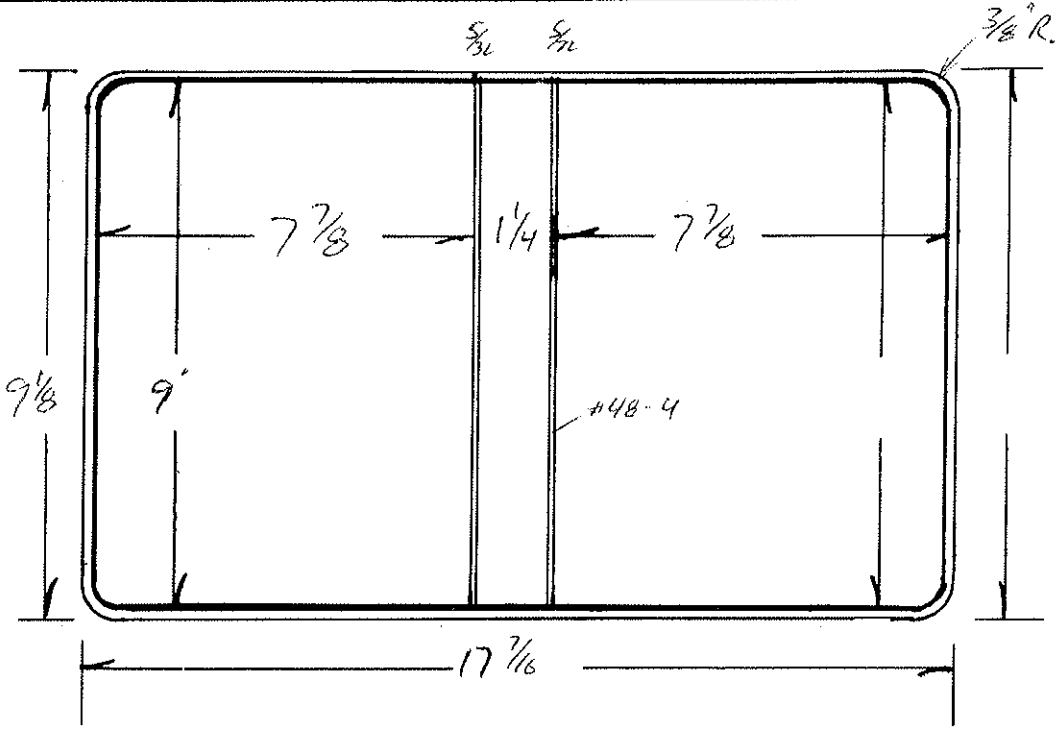

Code	Ga.	# PCS	Cutting Specs		Code	Ga.	# Pcs.	Cutting Specs	
			Size	Out				Size	Out
cover Mat.		14	9 3/4 X 18 1/4		Lining Mat.	14	1	9 3/4 X 18 1/4	
cover Mat			X		Lining Mat.			X	
ert. Pckt.			X		Horz. Pckt.	8	1	4 3/8 X 18 1/4	
ert. Pckt.			X		Horz. Pckt.			X	
Pocket			X		Pocket			X	
Label Holder			X		Card Holder			X	
aterial			X		Material			X	
aterial			X		Material			X	
aterial			X		Material			X	
.C. Board		100	8 5/16 X 7 13/16	1	B.C. Board			X	
.C. Board		100	8 5/16 X 7 13/16	1	B.B. Board			X	
enter Board		100	8 5/16 X 1 5/32	1	Board			X	
oard			X		Strip			X	
over Pad			X		Strip			X	
					B.B. Pad			X	

Product Code

Style Case

VRB Dring UB-A

Sheet Size 8 1/2

x 7 1/4

Cap. 1 1/2

Die No. 5231

Order No. 974017.1

Plate D14-6

Customer

Republic Financial Service

12-31

Metal
Total Vinyl
Quantity 2000
Date 12-7-92
Type Corners RJD
Radius 3/8
Completed

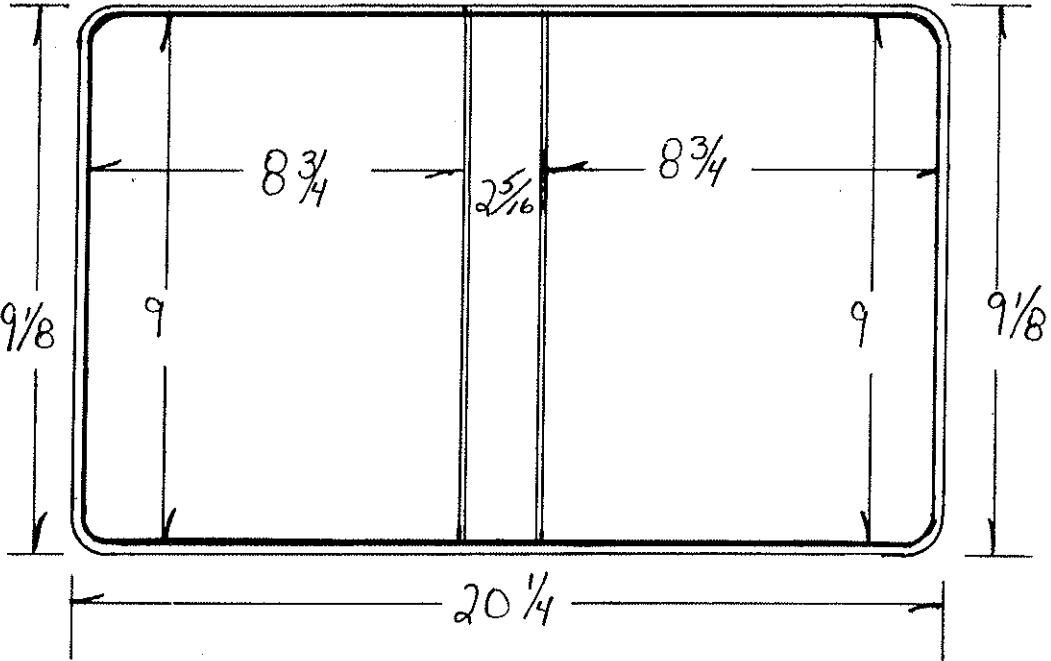

	Gauge	Thick
Tear Seal	.014	1/16
Bar Seal	484	5/32
Bar Seal		

	No. of Feet
Tear Seal	
Bar Seal	
Bar Seal	

Tim

Code	Ga.	# PCS	Cutting Specs		Code	Ga.	# Pcs.	Cutting Specs	
			Size	Out				Size	Out
Cover Mat.		1	9 1/8	X 21	Lining Mat.		1	9 1/8	X 21
Cover Mat.				X	Lining Mat.				X
Vert. Pckt.				X	Horz. Pckt.				X
Vert. Rckt.				X	Horz. Pckt.				X
Pocket				X	Pocket				X
Label Holder				X	Card Holder				X
Material				X	Material				X
Material				X	Material				X
Material				X	Material				X
F.C. Board		120	1	8 29/32 X 8 21/32	B.C. Board	100	1	8 15/16 X 8 11/16	
B.G. Board		120	1	8 29/32 X 8 21/32	B.B. Board	100	1	8 15/16 X 2 7/32	
Center Board		120	1	8 29/32 X 2 7/32	Board	100	1	8 15/16 X 8 11/16	
Board				X	Strip				X
Cover Pad				X	Strip				X
					B.B. Pad				X





Angle Per Sample

DIE # 5304	STYLE CASE VRB Dring	LOCATION D18-1
SHEET SIZE 8 1/2 x 5 1/2 + 1/2	CAP. 2	ORDER NO. 974672
CUSTOMER JC Penney		DUE DATE

QUANTITY	10000
DATE	3-19-93

RADIUS	1/4
COMPLETED	

TEAR SEAL	.014
BAR SEAL	102

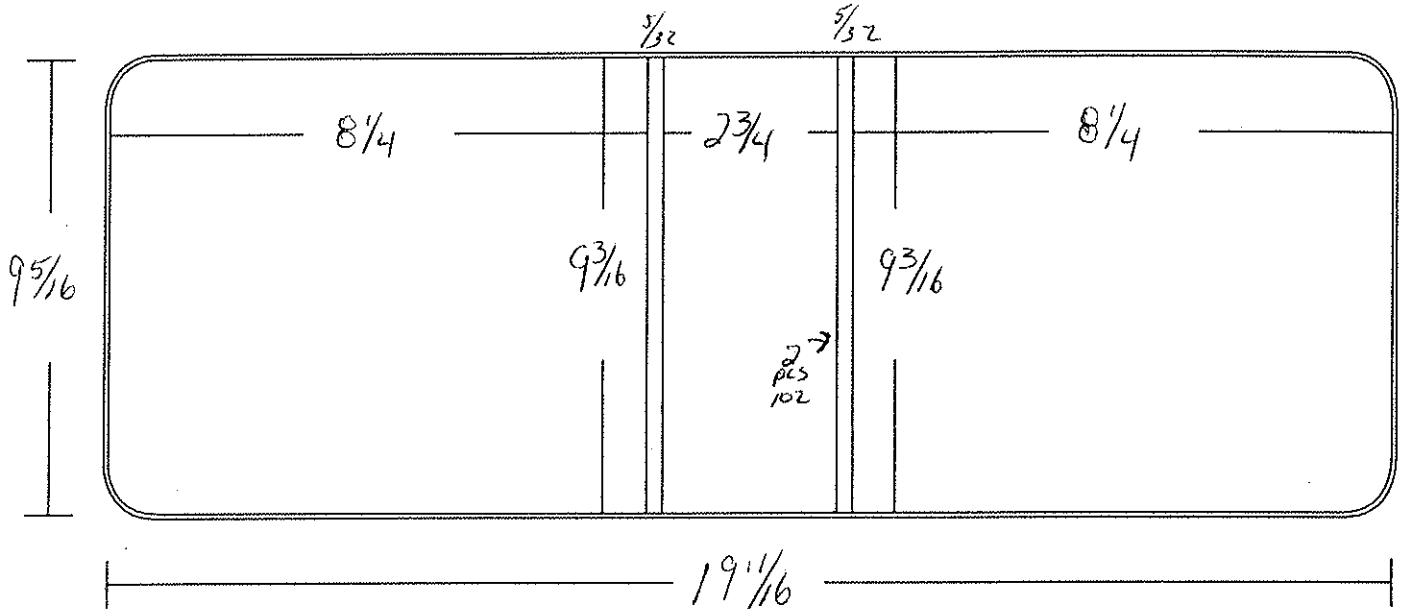

### MATERIAL

	CODE		GA	PCS		CODE		GA	PCS
COVER MATL		10 3/8 X 20 7/16		1	LINING		10 3/8 X 20 7/16		1
COVER MATL		X			LINING		X		
VERT PKT		X			HORZ PKT		4 7/8 X 8 13/16		1
VERT PKT		X			HORZ PKT		X		
CARD HOLDER	diecut	8 1/8 X 6 7/8			DIAGONAL PKT		X		
COL		X			LABEL HOLDER		X		
EX. COL		X			GUSSET		X		
		X			REINF.		X		
		X					X		

### PRINTS

FRONT COVER	X	BACK BONE	X	BACK COVER	X
-------------	---	-----------	---	------------	---

### BOARDS

	CODE		PT	PCS		CODE		PT	PCS
F.C. BOARD		9 1/8 X 8 3/16	100	1	F.C. BOARD		9 3/32 X 8 5/32	120	1
B.B. BOARD		9 1/8 X 2 2 1/32	100	1	B.B. BOARD		9 3/32 X 2 2 1/32	120	1
B.C. BOARD		9 1/8 X 8 3/16	100	1	B.C. BOARD		9 3/32 X 8 5/32	120	1
B. UP STRIP		X					X		
		X					X		

DIE #	5323	STYLE CASE	VRB Straight D NR	LOCATION	D19-6
SHEET SIZE	8 $\frac{1}{2}$ X 5 $\frac{1}{2}$ + $\frac{1}{2}$	CAP.	1 $\frac{1}{4}$	ORDER NO.	974976
CUSTOMER	Hester Associates			DUE DATE	

QUANTITY	200 + 7
DATE	5-3-93

RADIUS	3/8
COMPLETED	

TEAR SEAL	.012 Nat
BAR SEAL	484

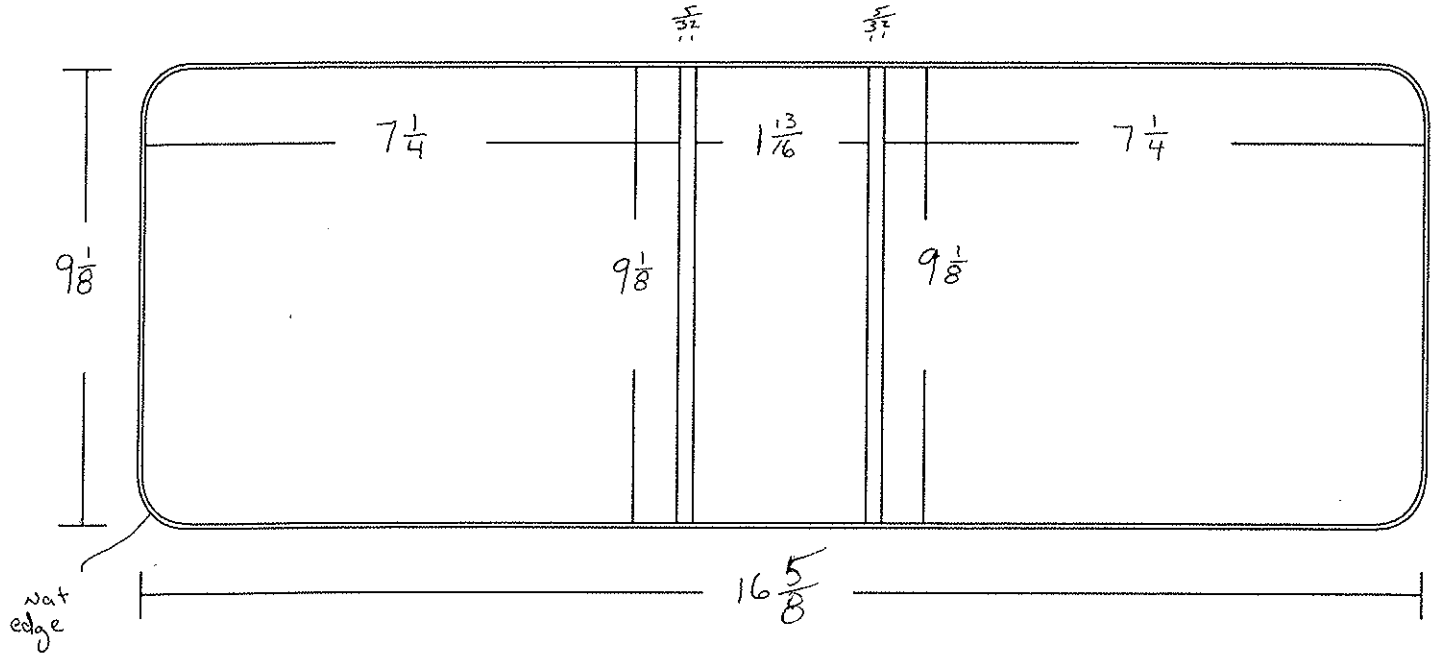

### MATERIAL

	CODE	GA	PCS		CODE	GA	PCS
COVER MATL	9 $\frac{7}{8}$ X 17 $\frac{1}{2}$		1	LINING	9 $\frac{7}{8}$ X 17 $\frac{1}{2}$		1
COVER MATL	X			LINING	X		
VERT PKT	X			HORZ PKT	4 $\frac{3}{8}$ X 17 $\frac{1}{2}$		
VERT PKT	X			HORZ PKT	X		
CARD HOLDER	X			DIAGONAL PKT	X		
COL	X			LABEL HOLDER	X		
EX. COL	X			GUSSETT	X		
	X			REINF.	X		
	X				X		

### PRINTS

FRONT COVER	X	BACK BONE	X	BACK COVER	X
-------------	---	-----------	---	------------	---

### BOARDS

	CODE	PT	PCS		CODE	PT	PCS
F.C. BOARD	9 $\frac{1}{16}$ X 7 $\frac{3}{16}$	100	1	F.C. BOARD	9 $\frac{1}{32}$ X 7 $\frac{5}{32}$	120	1
B.B. BOARD	9 $\frac{1}{16}$ X 1 $\frac{23}{32}$	100	1	B.B. BOARD	9 $\frac{1}{32}$ X 1 $\frac{23}{32}$	120	1
B.C. BOARD	9 $\frac{1}{16}$ X 7 $\frac{3}{16}$	100	1	B.C. BOARD	9 $\frac{1}{32}$ X 7 $\frac{5}{32}$	120	1
B. UP STRIP	X				X		
	X				X		

Slipcase Die # 5418

UB (Undershield)

DIE #5417		STYLE CASE VRB D RING 2" ADV. D		LOCATION E6-6	
SHEET SIZE 8 1/2 x 5 1/2 + 1/2		CAP. 2		ORDER # 976084	
CUSTOMER UNIQUEST INC.				DUE DATE	
QUANTITY	2000	RADIUS	1/4	TEAR SEAL	.012
DATE	9-13-93	COMPLETED		BAR SEAL	485

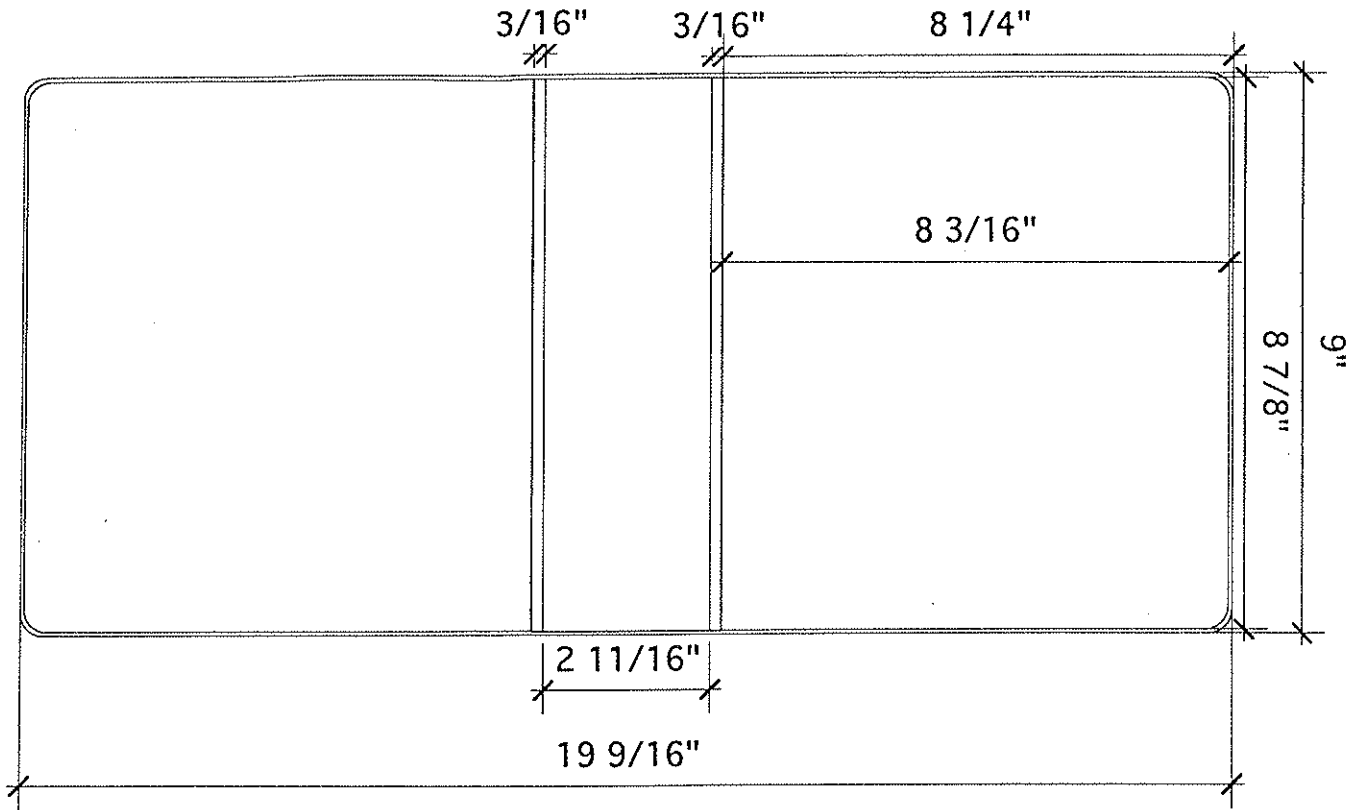

MATERIAL SPECS		GA		PCS	
COVER MATL	9 3/4 x 20 5/16	1	LINING	9 3/4 x 20 5/16	1
COVER MATL			LINING		
VERT PKT			HORZ PKT		
VERT PKT			HORZPKT		
CARD HOLDER			DIAGONAL PKT		
COL			LABEL HOLDER	9 1/4 x 4	1
EX COL			GUSSETT		
			REINF		

BOARD SPECS					
F.C. BOARD	8 25/32 x 8 3/32	120		F.C. BOARD	
B.B. BOARD	8 25/32 x 2 19/32	120	1	B.B. BOARD	
B.C. BOARD	8 25/32 x 8 3/32	120		B.C. BOARD	
BU STRIP					

Angle D

DIE # 5549		STYLE CASE VINYL RING BINDER		LOCATION E8-3	
SHEET SIZE 8 1/2 x 6		CAP. 3		ORDER # 977683	
CUSTOMER PERKINS				DUE DATE	
QUANTITY		RADIUS	3/8	TEAR SEAL	.012
DATE		COMPLETED		BAR SEAL	484

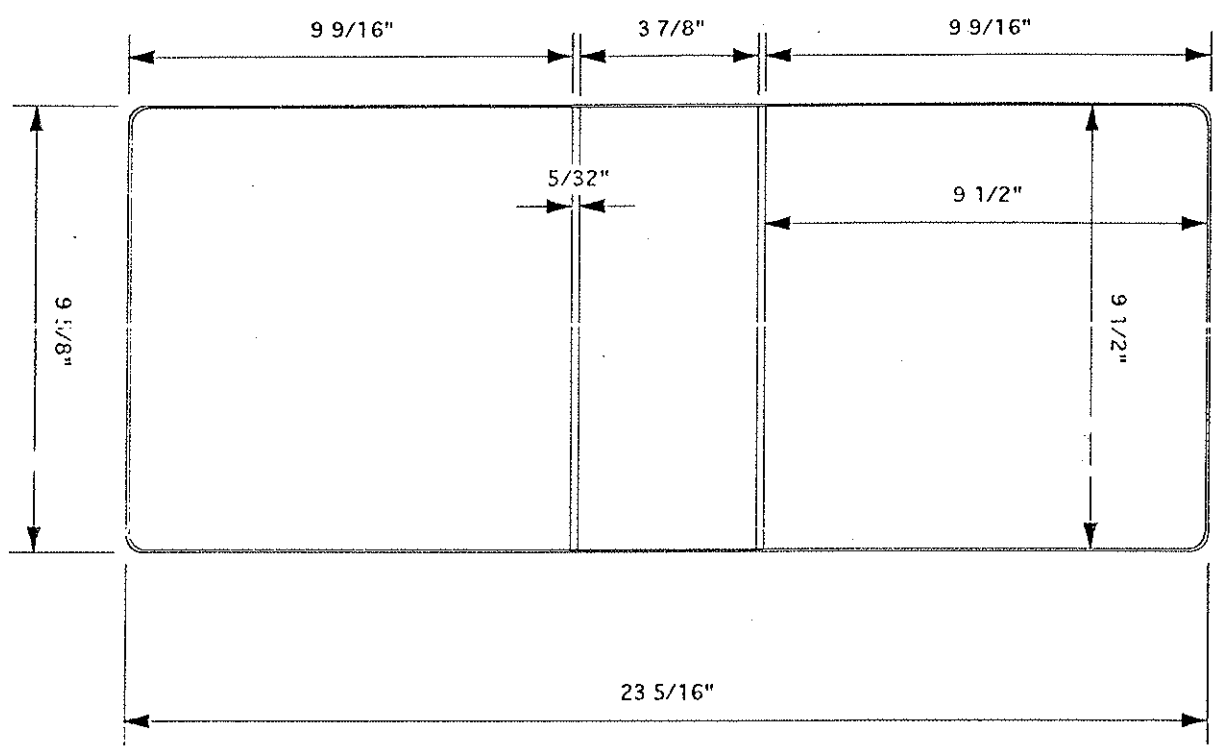

MATERIAL SPECS	GA	PCS		GA	PCS
COVER MATL	10 3/8 x 24 1/16	1	LINING	10 3/8 x 24 1/16	
COVER MATL			LINING		
VERT PKT			HORZ PKT		
VERT PKT			HORZPKT		
CARD HOLDER			DIAGONAL PKT		
COL			LABEL HOLDER		
EX COL			GUSSETT		
			REINF		

BOARD SPECS					
F.C. BOARD	<del>9 13/32 x 9 13/32</del> 120	1	F.C. BOARD	9 7/16 x 9 7/16	1
B.B. BOARD	<del>9 13/32 x 3 25/32</del> 120	1	B.B. BOARD	9 7/16 x 3 25/32	1
B.C. BOARD	<del>9 13/32 x 9 13/32</del> 120	1	B.C. BOARD		
BU STRIP					

HELDS HIGH ADVANTAGE ANGLE W/ NO BOOSTER

*Beaded Edge Die # 5886*

DIE # 5584		STYLE CASE		LOCATION E 10-4	
SHEET SIZE 8 1/2 X 6		CAP. 1		ORDER # 978298	
CUSTOMER ADR			DUE DATE		
QUANTITY		RADIUS		TEAR SEAL	NAT EDGE
DATE		COMPLETED		BAR SEAL	484

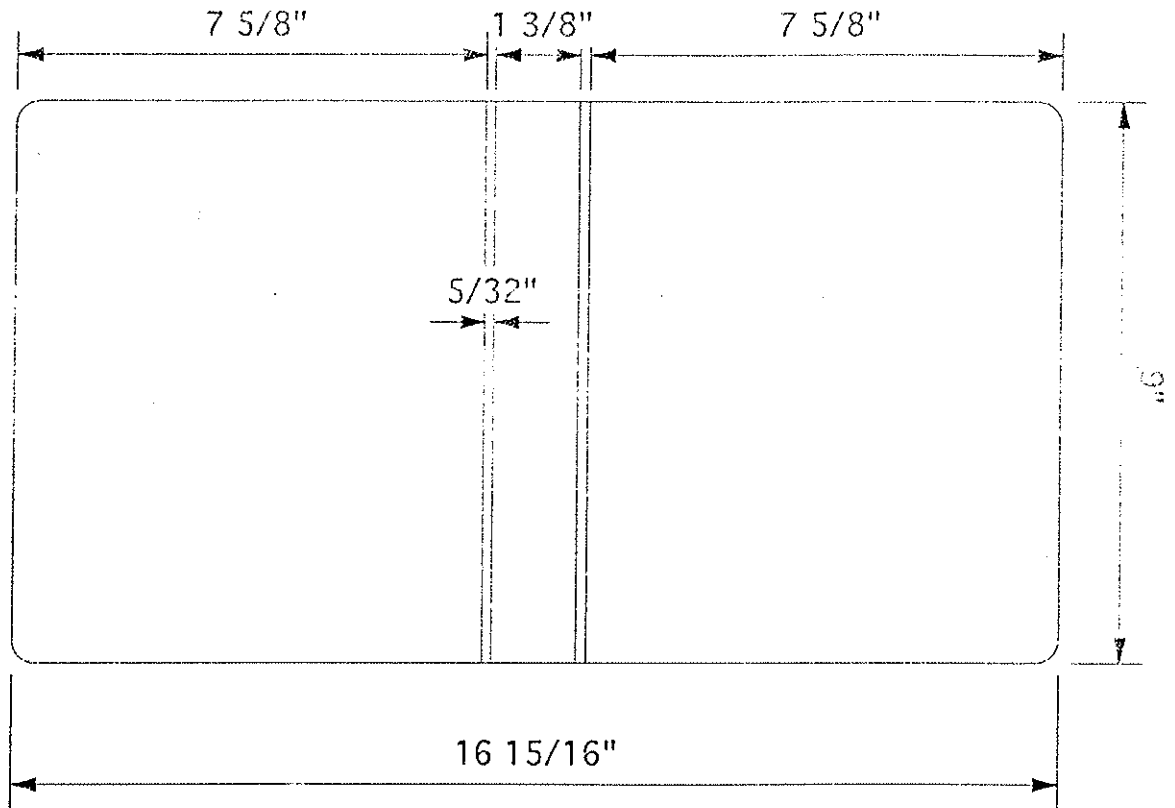

MATERIAL SPECS		GA		PCS	
COVER MATL	9 3/4 X 17 11/16	1	LINING	9 3/4 X 17 11/16	1
COVER MATL			LINING		
VERT PKT			HORZ PKT	4 7/8 X 8 1/8	1
VERT PKT			HORZPKT		
CARD HOLDER			DIAGONAL PKT		
COL			LABEL HOLDER		
EX COL			GUSSETT		
			REINF		

BOARD SPECS					
F.C. BOARD	8 7/8 X 7 9/16	100	1	F.C. BOARD	
B.B. BOARD	8 7/8 X 1 9/32	100	1	B.B. BOARD	
B.C. BOARD	8 7/8 X 7 9/16	100	1	B.C. BOARD	
BU STRIP					

DIE # 5759-A		CAP. 1"		METAL 1" STR D NB	
STYLE CASE VINYL RING BINDER				LOCATION E-19-1	
SHEET SIZE 8 1/4 X 7 3/4			ORDER # 980366		
CUSTOMER SIEMENS IND AUTO				DUE DATE 2-3-95	
QUANTITY	1000	RADIUS	1/4	TEAR SEAL	.014
DATE	1-19-95	COMPLETED		BAR SEAL	48-4

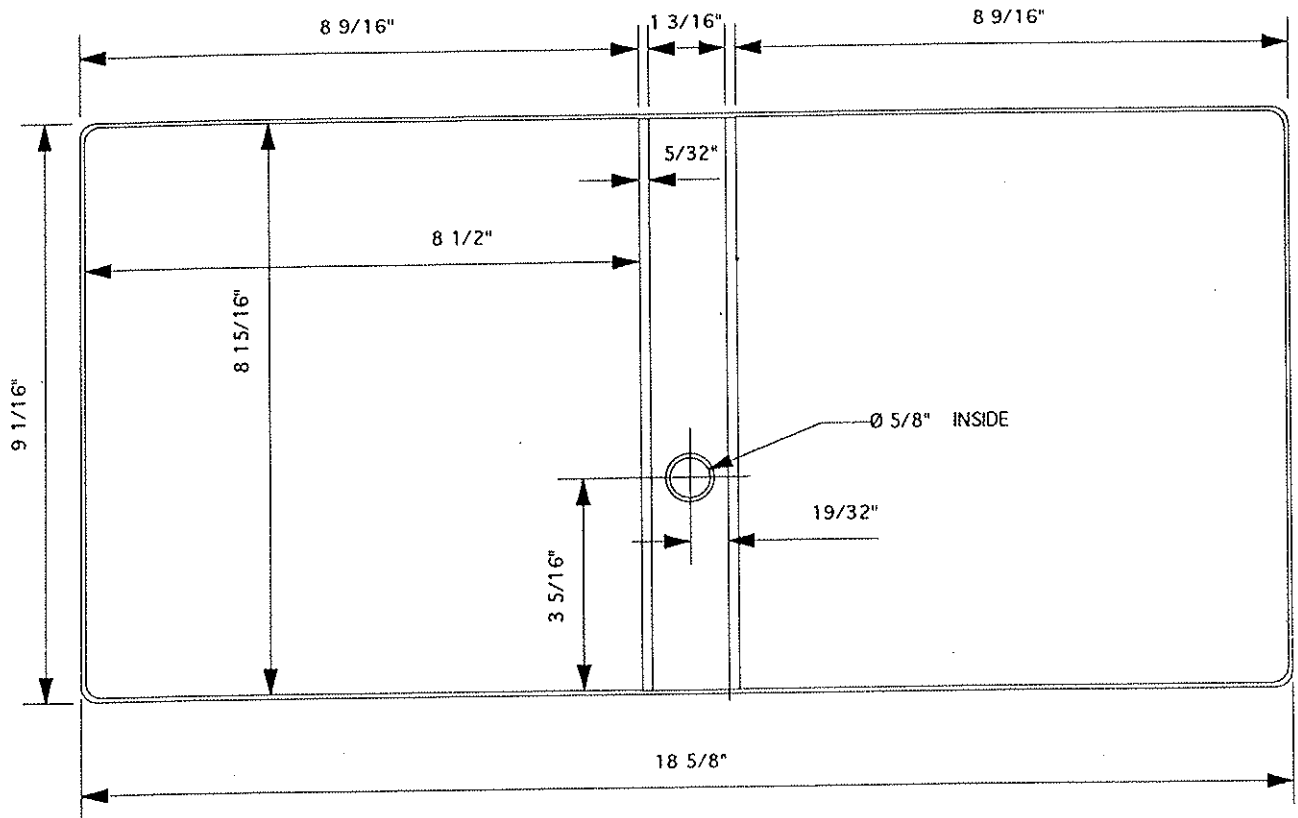

MATERIAL SPECS		GA	PCS	GA		PCS
COVER MAT.	9 13/16 X 19 3/8	1		LINING MAT	9 13/16 X 19 3/8	1
COVER MAT.				LINING MAT		
VERT PKT				HORZ PKT	6 1/4 X 9 1/8	1
CARD HOLDER				GUSSET		
COL				DIAGONAL PKT		
LABEL HOLDER	1 7/16 X 2 3/8	1		REINF		
BOARD SPECS		GA	PCS	GA		PCS
F.C. BOARD	8 7/8 X 8 7/16	100	1	F.C. BOARD		
B.B. BOARD	SEE 5759-B 9 7/8 x 3" 1/4 (2-out No Cut)			B.B. BOARD		
B.C. BOARD	8 7/8 X 8 7/16	100	1	B.C. BOARD		
B.U. STRIP						

DIE #	5811-A	CAP.	2"	METAL	2" STR D.
STYLE CASE	VINYL RING BINDER				LOCATION
SHEET SIZE	8 1/2 X 6			ORDER #	981043
CUSTOMER	ZBR PUBLISHING			DUE DATE	4/12/95
QUANTITY	200	RADIUS	3/8		TEAR SEAL .014
DATE	3-28-95	COMPLETED			BAR SEAL 102

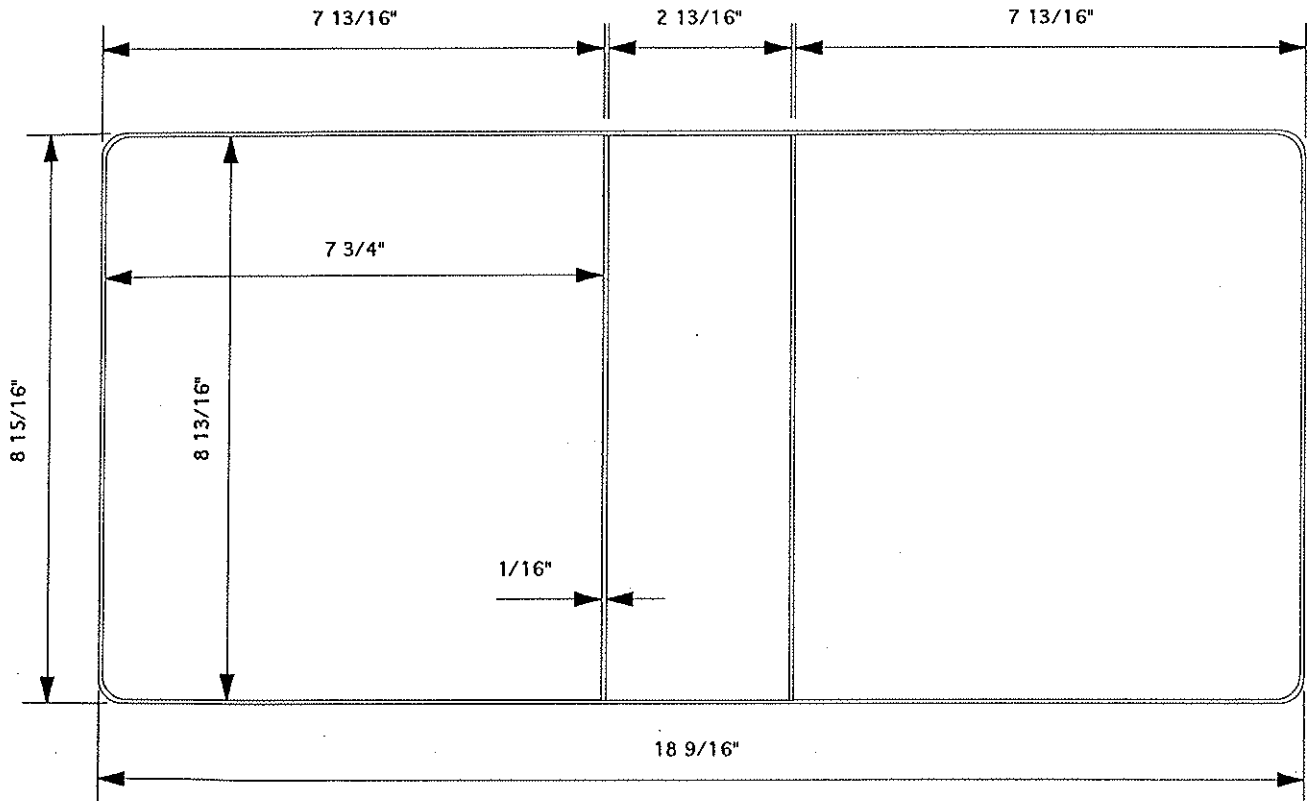

MATERIAL SPECS		GA	PCS	GA	PCS	
COVER MAT.	9 3/4 X 19 1/4		1	LINING MAT	9 3/4 X 19 1/4	1
COVER MAT.				LINING MAT		
VERT PKT				HORZ PKT	5 3/8 X 8 1/4	1
CARD HOLDER	4 7/8 X 2 3/4	LT 5811-B	1	GUSSET		
COL				DIAGONAL PKT		
LABEL HOLDER	2 1/8 X 3		1	REINF		
BOARD SPECS		GA	PCS	GA	PCS	
F.C. BOARD	8 23/32 X 7 21/32	120	1	F.C. BOARD		
B.B. BOARD	8 23/32 X 2 23/32	120	1	B.B. BOARD		
B.C. BOARD	8 23/32 X 7 21/32	120	1	B.C. BOARD		
B.U. STRIP						

Natural Edge Die # 5584

DIE #	5886	METAL	ADVANTAGE ANGLE D	RADIUS	3/8
ORDER #		CUSTOMER		TEAR SEAL	.014
SHEET SIZE	8 1/2 X 6	STYLE CASE	BEADED EDGE VERSION OF 5584	BAR SEAL	48-4
CAP.	1"	DUE DATE		COMPLETED	
LOCATION	F-11-3	QUANTITY		DATE	8-9-95

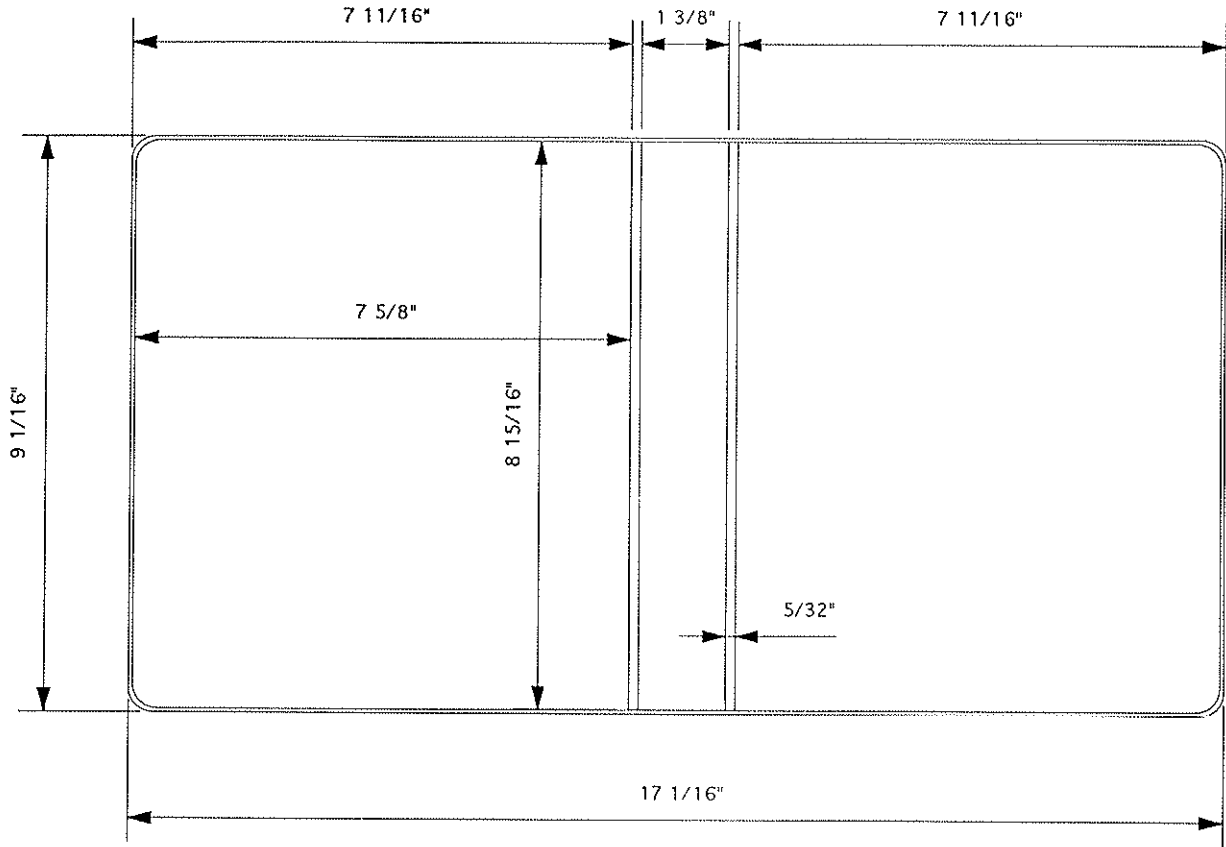

MATERIAL SPECS		GAUGE		MATERIAL SPECS		GAUGE	
COVER MAT.	9 3/4 X 17 11/16		1	LINING MAT.	9 3/4 X 17 11/16		1
COVER MAT.				LINING MAT.			
DIE CUT				HORZ. PKT.	4 7/8 X 8 1/8		1
COL				VERT. PKT.			
LABEL HOLDER				DIE CUT			
GUSSET				REINF.			

BOARD SPECS		GAUGE		BOARD SPECS		GAUGE	
F.C. BOARD	8 7/8 X 7 9/16	100	1	F.C. BOARD			
B.B. BOARD	8 7/8 X 1 9/32	100	1	B.B. BOARD			
B.C. BOARD	8 7/8 X 7 9/16	100	1	B.C. BOARD			
B.U. STRIP				DIE CUT			
DIE CUT				DIE CUT			



DIE #	6114	METAL	3" ANGLE D W/B	RADIUS	3/8"
ORDER #	2001458	CUSTOMER	NAZARENE PUBLISHING	TEAR SEAL	.014
SHEET SIZE	8 1/2 X 11 1/2	STYLE CASE	VINYL RING BINDER	BAR SEAL	254
CAP.	3"	DUE DATE	9-13-96	COMPLETED	
LOCATION	NELL	QUANTITY	150	DATE	9-3-96

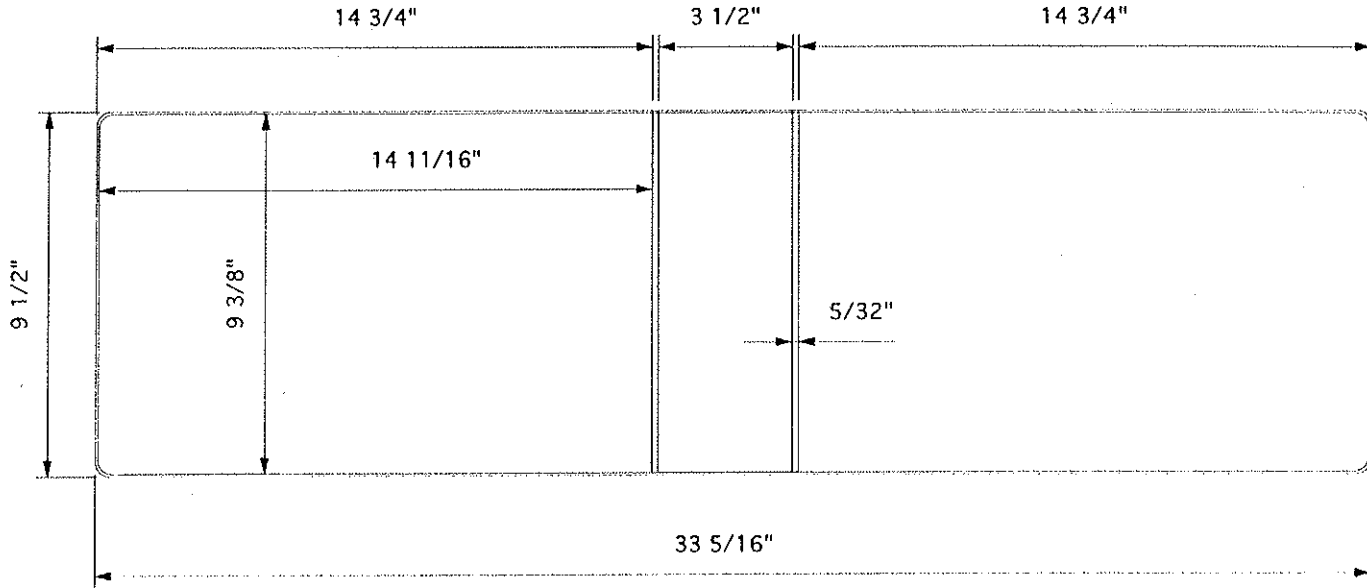

MATERIAL SPECS		GAUGE PCS.		MATERIAL SPECS		GAUGE	
COVER MAT.	10 1/4 X 34 1/8		1	LINING MAT.	10 1/4 X 34 1/8		
COVER MAT.				LINING MAT.			
DIE CUT				HORZ. PKT.			
COL				VERT. PKT.			
LABEL HOLDER	9 5/8 X 3 15/16		1	DIE CUT			
GUSSET				REINF.			

BOARD SPECS		GAUGE PCS.		BOARD SPECS		GAUGE	
F.C. BOARD	9 9/32 X 14 19/32	120	1	F.C. BOARD			
B.B. BOARD	9 9/32 X 3 13/32	120	1	B.B. BOARD			
B.C. BOARD	9 9/32 X 14 19/32	120	1	B.C. BOARD			
FLAP BD.				DIE CUT			
BOARD				DIE CUT			

Fab Die # 6151

DIE #	6122	METAL	ANGLE D	RADIUS	3/8"
ORDER #	985552	CUSTOMER	QMS INC	TEAR SEAL	.104
SHEET SIZE	8 1/2 X 6 1/2	STYLE CASE	VRB	BAR SEAL	253
CAP.	1 1/2"	DUE DATE	9-30-96	COMPLETED	
LOCATION	G-4-1	QUANTITY	2500	DATE	9-25-96

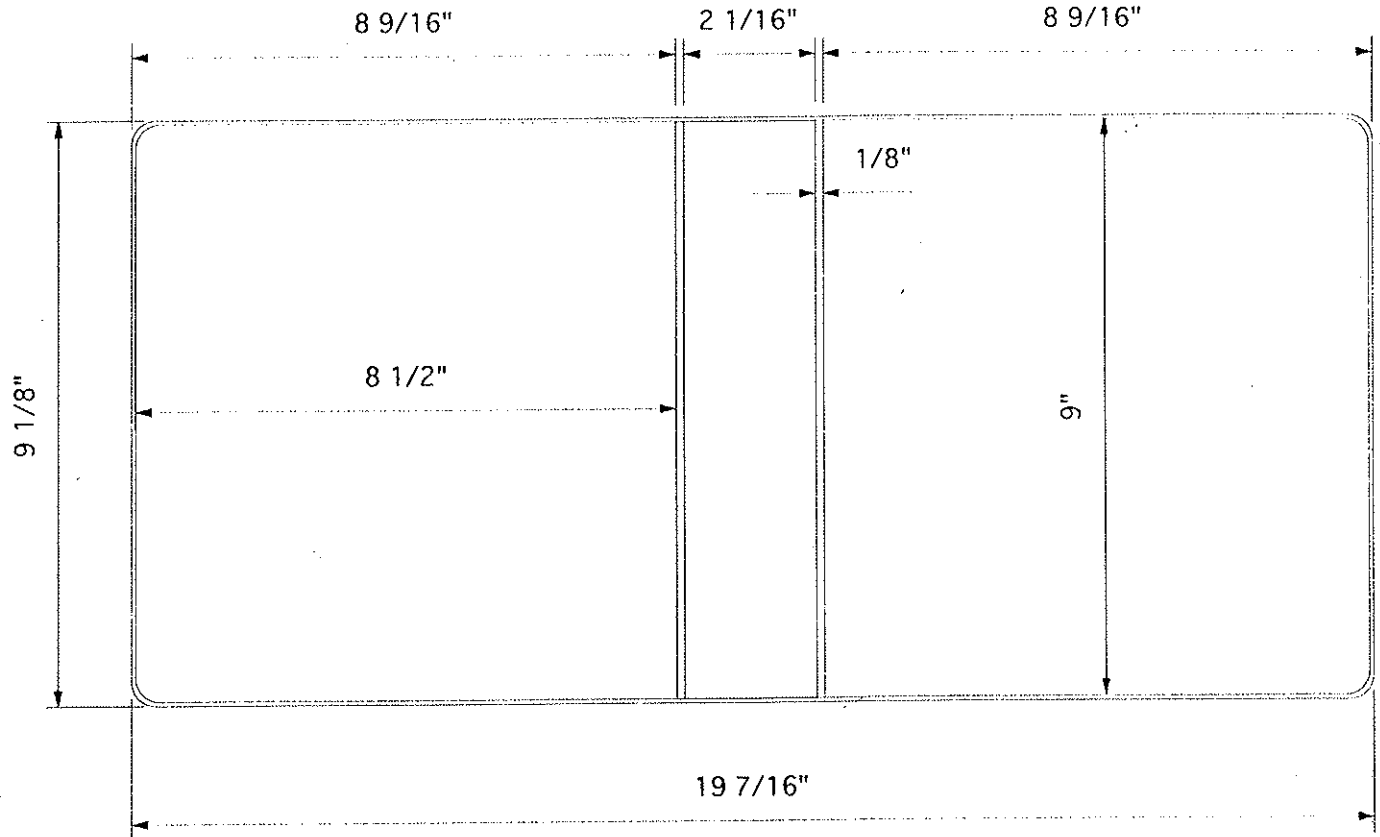

MATERIAL SPECS		GAUGE		PCS.		MATERIAL SPECS		GAUGE	
COVER MAT.	9 7/8 X 20 1/4			1		LINING MAT.	9 7/8 X 20 1/4		
COVER MAT.	9 5/16 X 20 1/4			1		LINING MAT.			
DIE CUT						HORZ. PKT.			
COL						VERT. PKT.			
LABEL HOLDER						DIE CUT			
GUSSET						REINF.			
BOARD SPECS		GAUGE		PCS.		BOARD SPECS		GAUGE	
F.C. BOARD	8 29/32 X 8 13/32	120		1		F.C. BOARD			
B.B. BOARD	8 29/32 X 1 31/32	120		1		B.B. BOARD			
B.C. BOARD	8 29/32 X 8 13/32	120		1		B.C. BOARD			
FLAP BD.						DIE CUT			
BOARD						DIE CUT			

DIE #	6254	METAL	BENSON STR D NB	RADIUS	3/8"
ORDER #	987287	CUSTOMER	DRESSER INDUSTRIES	TEAR SEAL	.014
SHEET SIZE	8 1/2 X 6	STYLE CASE	VINYL RING BINDER	BAR SEAL	178
CAP.	2 1/2"	DUE DATE	6-3-97	COMPLETED	
LOCATION	H-4-3	QUANTITY	300	DATE	5-23-97

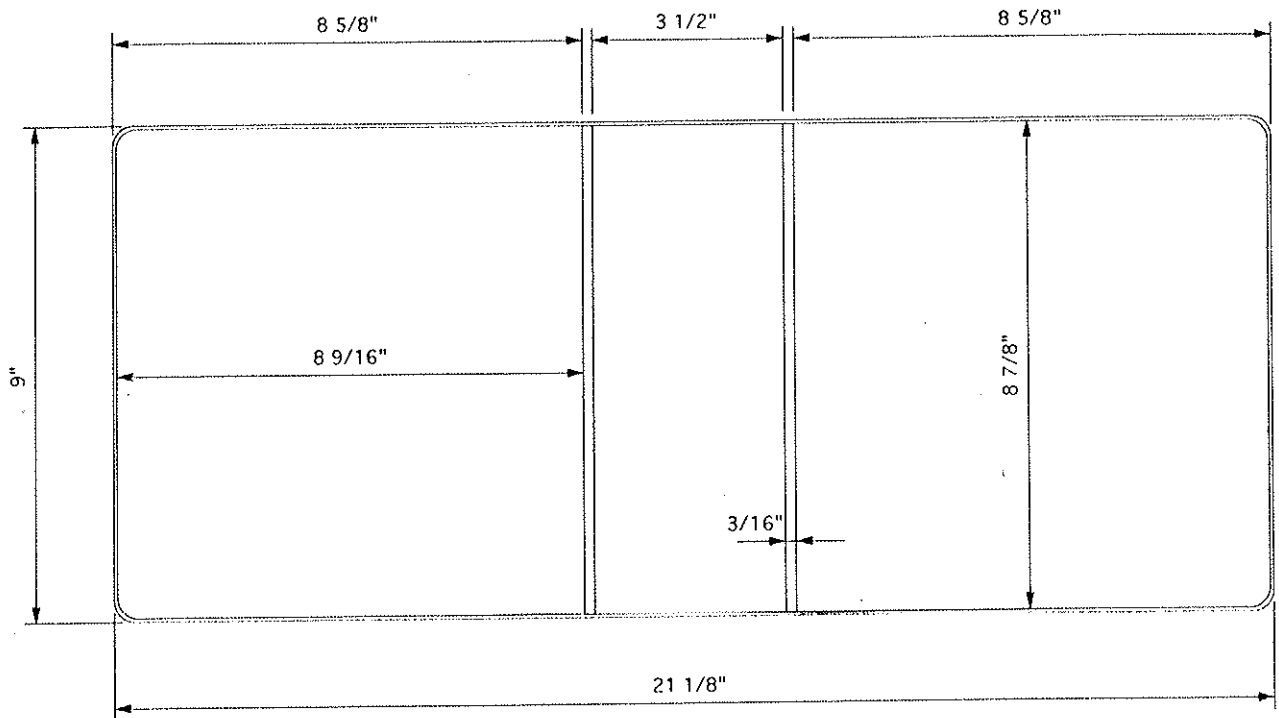

MATERIAL SPECS		GAUGE PCS		MATERIAL SPECS		GAUGE F	
COVER MAT.	9 3/4 X 21 7/8		1	LINING MAT.	9 3/4 X 21 7/8		
COVER MAT.				LINING MAT.			
DIE CUT				HORZ. PKT.	4 3/8 X 9 1/4		
COL				VERT. PKT.			
LABEL HOLDER				DIE CUT			
GUSSET				REINF.	8 13/16 X 4 5/8		SKRIM
BOARD SPECS		GAUGE PCS.		BOARD SPECS		GAUGE I	
F.C. BOARD	8 13/16 X 8 1/2	120	1	F.C. BOARD			
B.B. BOARD	8 13/16 X 3 13/32	120	1	B.B. BOARD			
B.C. BOARD	8 13/16 X 8 1/2	120	1	B.C. BOARD			
FLAP BD.				DIE CUT			
BOARD				DIE CUT			

and W/B

DIE #	6269	METAL	ANGLE D W/BOOSTER	RADIUS	3/8"
ORDER #	987405	CUSTOMER	REGENCY PRESS	TEAR SEAL	.014
SHEET SIZE	8.5 X 6	STYLE CASE	VINYL RING BINDER	BAR SEAL	253
CAP.	2 1/2"	DUE DATE	6-24-97	COMPLETED	
LOCATION	H-3-2	QUANTITY	1500	DATE	6-18-97

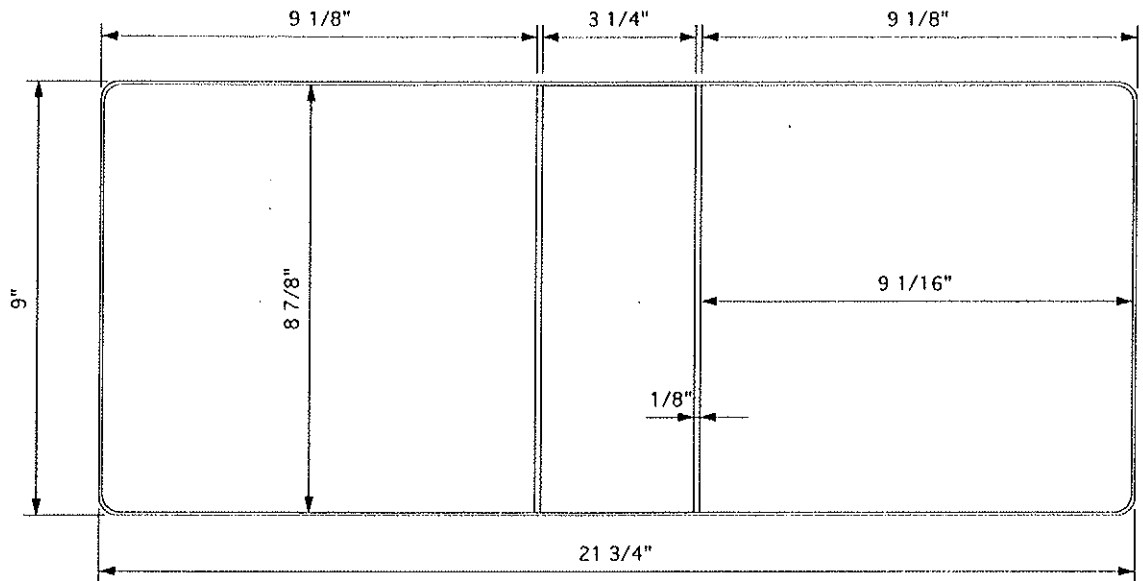

MATERIAL SPECS		GAUGE		PCS.		MATERIAL SPECS		GAUGE		PCS.	
COVER MAT.	9 3/4 X 22 1/2			1		LINING MAT.	9 3/4 X 22 1/2			1	
COVER MAT.						LINING MAT.					
DIE CUT						HORZ. PKT.					
COL	9 3/16 X 13			1		VERT. PKT.					
LABEL HOLDER						DIE CUT					
GUSSET						REINF.					

BOARD SPECS		GAUGE		PCS.		BOARD SPECS		GAUGE		PCS.	
F.C. BOARD	8 25/32 X 8 31/32	120		1		F.C. BOARD					
B.B. BOARD	8 25/32 X 3 5/32	120		1		B.B. BOARD					
B.C. BOARD	8 25/32 X 8 31/32	120		1		B.C. BOARD					
FLAP BD.						DIE CUT					
BOARD						DIE CUT					

and  $\frac{1}{8}$ "

DIE #	6269	METAL	ANGLE D W/BOOSTER	RADIUS	3/8"
ORDER #	987405	CUSTOMER	REGENCY PRESS	TEAR SEAL	.014
SHEET SIZE	8.5 X 6	STYLE CASE	VINYL RING BINDER	BAR SEAL	253
CAP.	2 1/2"	DUE DATE	6-24-97	COMPLETED	
LOCATION	H-3-2	QUANTITY	1500	DATE	6-18-97

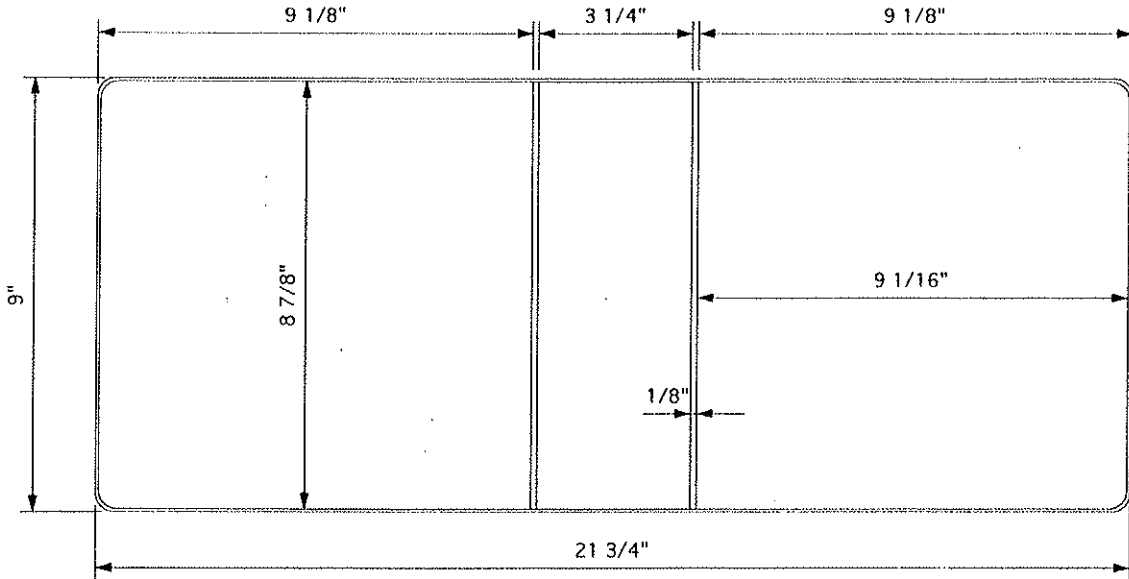

MATERIAL SPECS		GAUGE		PCS.		MATERIAL SPECS		GAUGE		PCS.	
COVER MAT.	9 3/4 X 22 1/2			1		LINING MAT.	9 3/4 X 22 1/2			1	
COVER MAT.						LINING MAT.					
DIE CUT						HORZ. PKT.					
COL	9 3/16 X 13			1		VERT. PKT.					
LABEL HOLDER						DIE CUT					
GUSSET						REINF.					
BOARD SPECS		GAUGE		PCS.		BOARD SPECS		GAUGE		PCS.	
F.C. BOARD	8 25/32 X 8 31/32	120		1		F.C. BOARD					
B.B. BOARD	8 25/32 X 3 5/32	120		1		B.B. BOARD					
B.C. BOARD	8 25/32 X 8 31/32	120		1		B.C. BOARD					
FLAP BD.						DIE CUT					
BOARD						DIE CUT					

DIE #	6564	METAL	ANGLE D NB	RADIUS	3/8"
ORDER #	163619	CUSTOMER	HOLTZ MARKETING	TEAR SEAL	.014
SHEET SIZE	8 1/2 X 7 1/2	STYLE CASE	VINYL BINDER	BAR SEAL	253
CAP.	2 1/2"	DUE DATE	9-18-98	COMPLETED	
LOCATION	A-19-5	QUANTITY	300	DATE	9-14-98

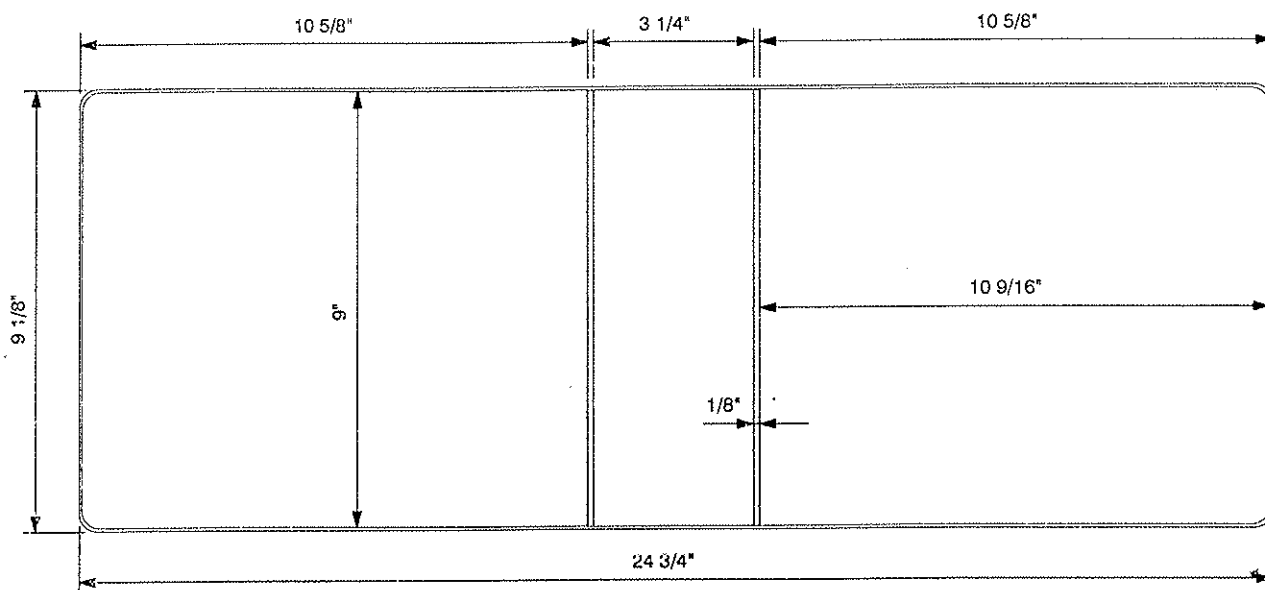

MATERIAL SPECS		GAUGE	PCS.	MATERIAL SPECS		GAUGE			
COVER MAT.	9 7/8 X 25 1/2		1	LINING MAT.	9 7/8 X 25 1/2				
COVER MAT.	9 7/8 X 25 1/2		1	LINING MAT.					
DIE CUT				HORZ. PKT.					
COL				VERT. PKT.					
LABEL HOLDER				DIE CUT					
GUSSET				REINF.					
BOARD SPECS		9/16" R. CORNERS		GAUGE	PCS.	BOARD SPECS	9/16" R. CORNERS		GAUGE
F.C. BOARD	8 29/32 X 10 15/32	120	1	F.C. BOARD					
B.B. BOARD	8 29/32 X 3 5/32	120	1	B.B. BOARD					
B.C. BOARD	8 29/32 X 10 15/32	120	1	B.C. BOARD					
FLAP BD.				DIE CUT					
BOARD				DIE CUT					