

STOCK

Customer _____
 Metal _____
 Total Vinyl _____
 Quantity _____
 Date 6-30-92
 Type Corners _____
 Radius _____
 Completed _____

	Gauge	Thick
Clear Seal	.014	1/16
Bar Seal	#178	3/16
Bar Seal		

	No. of Feet
Clear Seal	
Bar Seal	
Bar Seal	

Draw. B.Pace

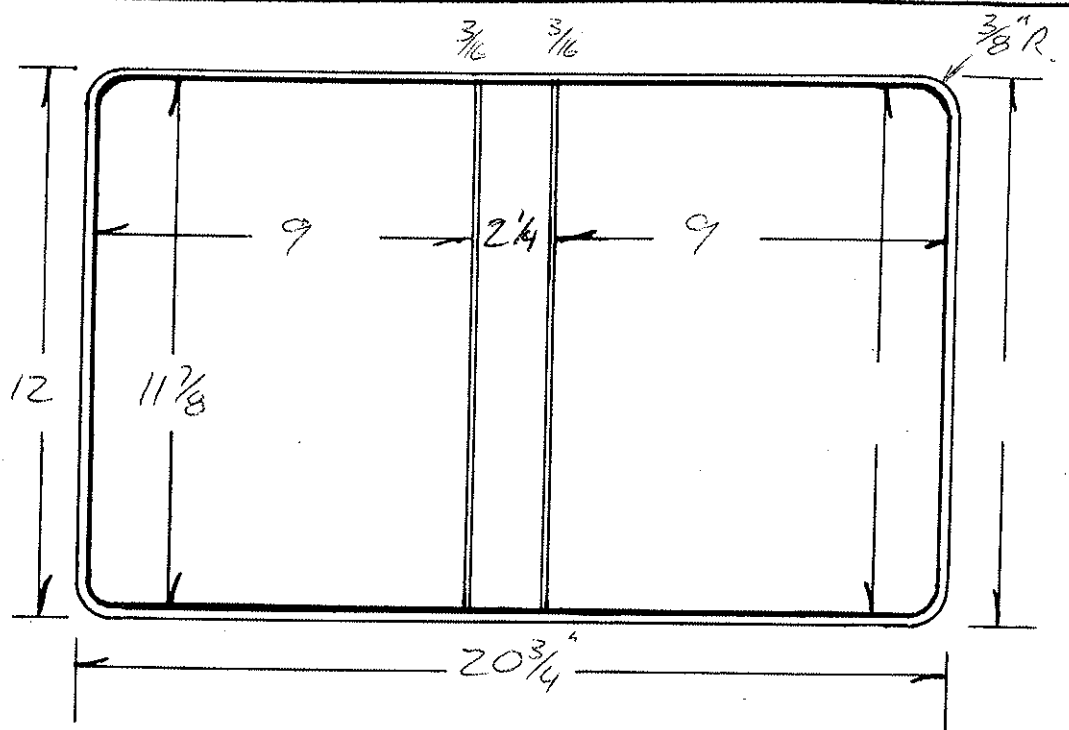

Code	Ga.	#	Cutting Specs		Code	Ga.	#	Cutting Specs	
			Size	Out				Size	Out
Cover Mat.			12 3/4 x 2 1/2	1	Lining Mat.			12 3/4 x 2 1/2	1
Cover Mat			X		Lining Mat.			X	
Vert. Pckt.			X		Horz. Pckt.			X	
Vert. Pckt.			X		Horz. Pckt.			X	
Pocket			X		Pocket			X	
Label Holder			X		Card Holder			X	
Material			X		Material			X	
Material			X		Material			X	
Material			X		Material			X	
B.C. Board			11 13/16 x 8 5/16	100	B.C. Board			X	
B.C. Board			11 13/16 x 8 5/16	100	B.B. Board			11 13/16 x 2 5/32	100
Center Board			X		Board			X	
Board			X		Strip			X	
Cover Pad			X		Strip			X	
					B.B. Pad			X	

SHOOTING TIMES - STOCK

Customer
 Metal
 Total Vinyl
 Quantity ?
 Date 7-13-92
 Type Corners
 Radius
 Completed

	Gauge	Thick
Bar Seal	.014	1/16
Bar Seal	.254	3/32
Bar Seal		

	No. of Feet
Bar Seal	
Bar Seal	
Bar Seal	

1-B. Piece

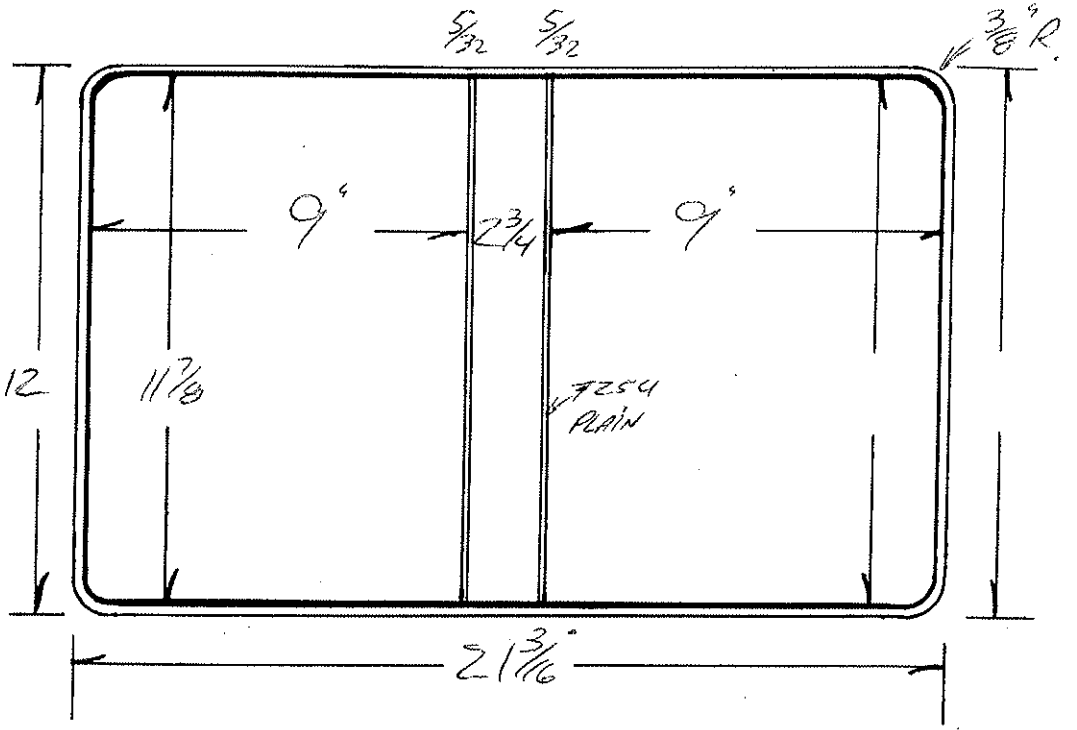

Code	Ga.	# PCS	Cutting Specs		Code	Ga.	# Pcs.	Cutting Specs.	
			Size	Out				Size	Out
Cover Mat.			12 3/4 X	22	Lining Mat.			12 3/4 X	22
Cover Mat			X		Lining Mat.			X	
vert. Pckt.			X		Horz. Pckt.			X	
vert. Pckt.			X		Horz. Pckt.			X	
Pocket			X		Pocket			X	
Label Holder			X		Card Holder			X	
Material			X		Material			X	
Material			X		Material			X	
Material			X		Material			X	
B.C. Board		100	11 13/16 X	8 15/16	B.C. Board			X	
B.C. Board		100	11 13/16 X	8 15/16	B.B. Board		100	11 13/16 X	2 2/32
Center Board			X		Board			X	
Board			X		Strip			X	
Cover Pad			X		Strip			X	
					B.B. Pad			X	

DIE #	4130	METAL	MBS	RADIUS	3/8"
ORDER #		CUSTOMER		TEAR SEAL	.104
SHEET SIZE	11 X 8 1/2	STYLE CASE	VINYL MAG. BINDER	BAR SEAL	253
CAP.	2 1/2"	DUE DATE		COMPLETED	
LOCATION		QUANTITY		DATE	6-4-03

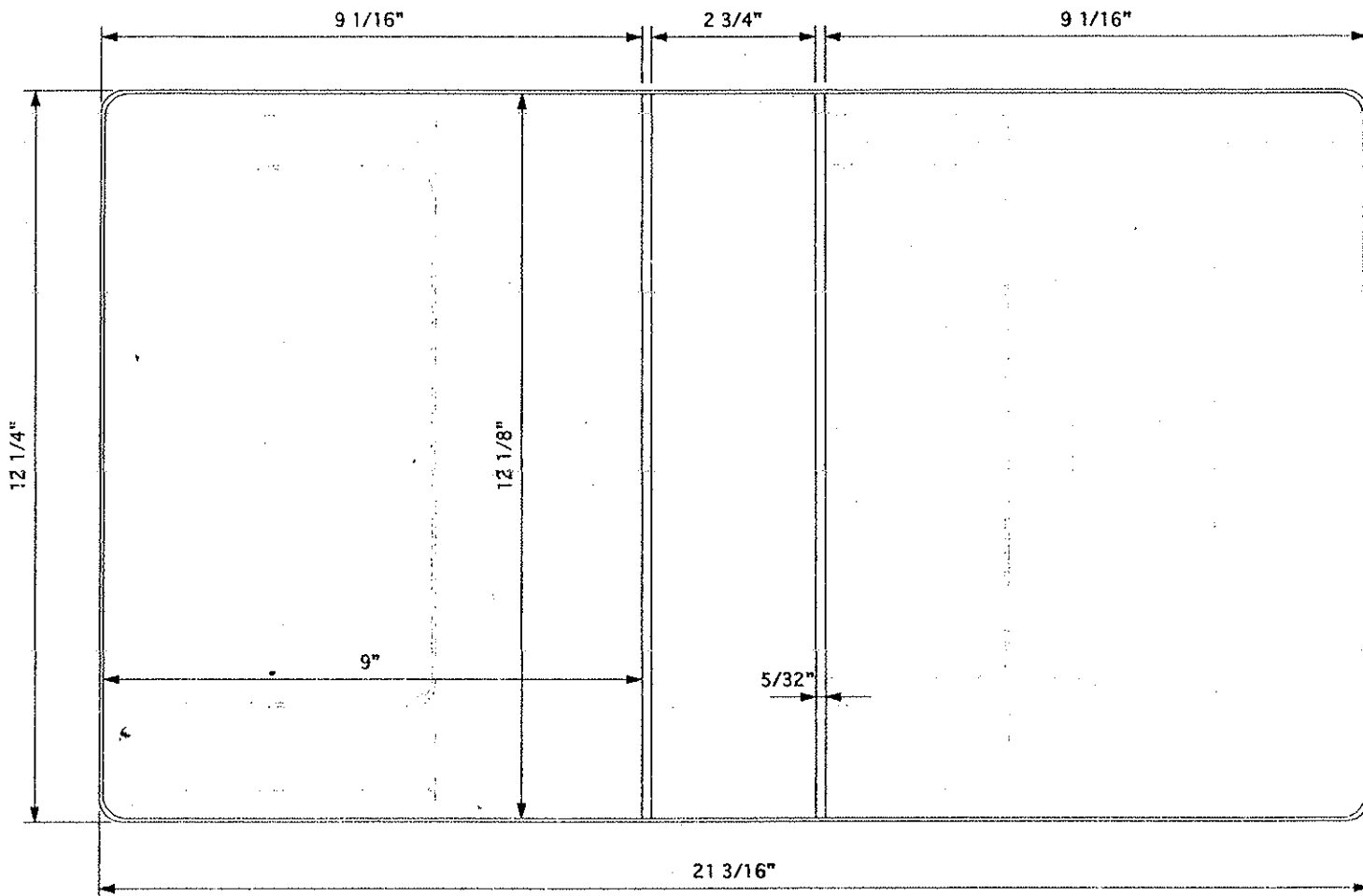

MATERIAL SPECS		GAUGE	PCS.	MATERIAL SPECS		GAUGE	PCS.	
COVER MAT.	13 X 22		1	LINING MAT.	13 X 22		1	
COVER MAT.				LINING MAT.				
DIE CUT				HORZ. PKT.				
COL				VERT. PKT.				
LABEL HOLDER				DIE CUT				
GUSSET				REINF.				
BOARD SPECS		5/16" R. CORNERS	GAUGE	PCS.	BOARD SPECS	5/16" R. CORNERS	GAUGE	PCS.
F.C. BOARD	12 1/16 X 8 15/16			1	F.C. BOARD			
B.B. BOARD	12 1/16 X 2 21/32			1	B.B. BOARD			
B.C. BOARD	12 1/16 X 8 15/16			1	B.C. BOARD			
FLAP BD.					DIE CUT			
BOARD					DIE CUT			

Customer KNITTING MACHINE CENTER

Material	
Total Vinyl	
Quantity	
Date	<u>6-19-89</u>
Type Corners	<u>RND.</u>
Radius	<u>3/8"</u>
Completed	

	Gauge	Thick
Ear Seal	<u>016</u>	<u>3/32</u>
Ear Seal	<u>#254</u>	<u>5/32"</u>
Ear Seal		

	No. of Feet
Ear Seal	
Ear Seal	
Ear Seal	

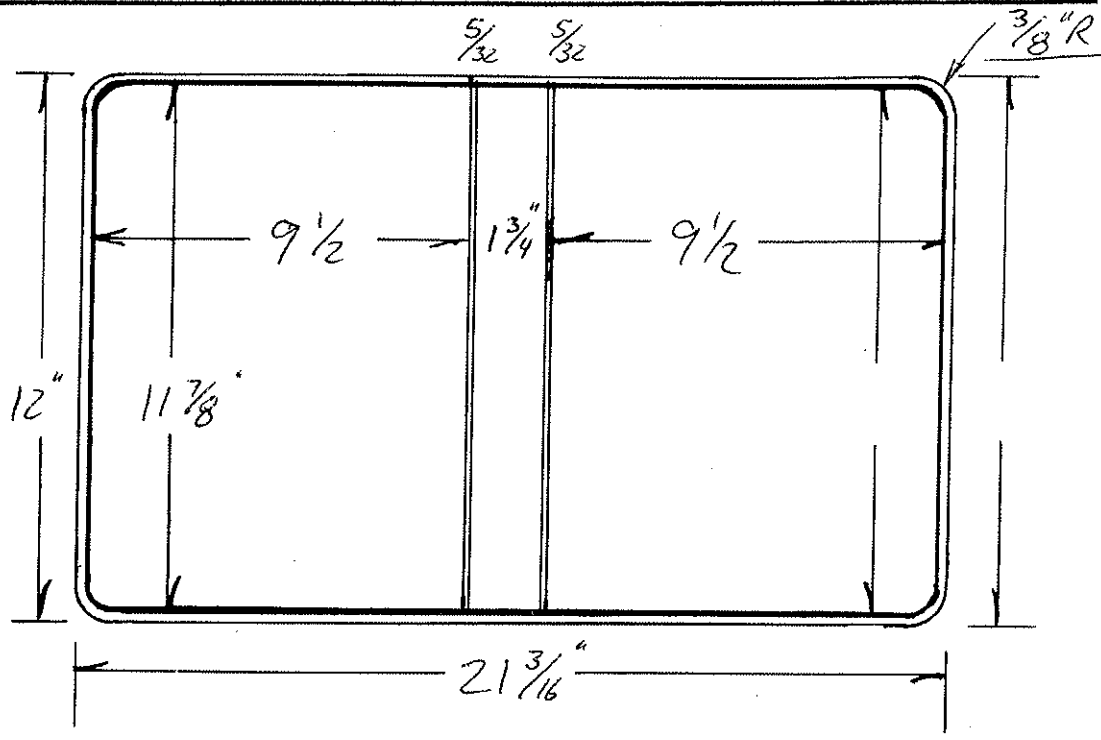

Code	Ga.	# PCS	Cutting Specs		Code	Ga.	# Pcs.	Cutting Specs	
			Size	Out				Size	Out
Over Mat.					Lining Mat.				
			<u>12 3/4 X 22</u>	<u>15</u>				<u>12 3/4 X 22</u>	<u>15</u>
Over Mat			X		Lining Mat.			X	
Art. Pckt.			X		Horz. Pckt.			X	
Art. Pckt.			X		Horz. Pckt.			X	
Pocket			X		Pocket			X	
Label Holder			X		Card Holder			X	
Material			X		Material			X	
Material			X		Material			X	
Material			X		Material			X	
B.C. Board					B.C. Board			X	
			<u>11 13/16 X 9 7/16</u>	<u>100</u>				<u>11 13/16 X 12 1/32</u>	<u>100</u>
B.C. Board			<u>11 13/16 X 9 7/16</u>	<u>100</u>	B.B. Board			<u>11 13/16 X 12 1/32</u>	<u>100</u>
Center Board			X		Board			X	
Board			X		Strip			X	
Over Pad			X		Strip			X	
					B.B. Pad			X	

Customer WORLD ADVERTISING 963-092;108;109;110;111;112

Metal
Total Vinyl
Quantity <u>42 X 6</u>
Date
Type Corners
Radius
Completed

	Gauge	Thick
Tear Seal	<u>.016"</u>	<u>3/32</u>
Bar Seal	<u>#178"</u>	<u>3/16</u>
Bar Seal		

	No. of Feet
Tear Seal	
Bar Seal	
Bar Seal	

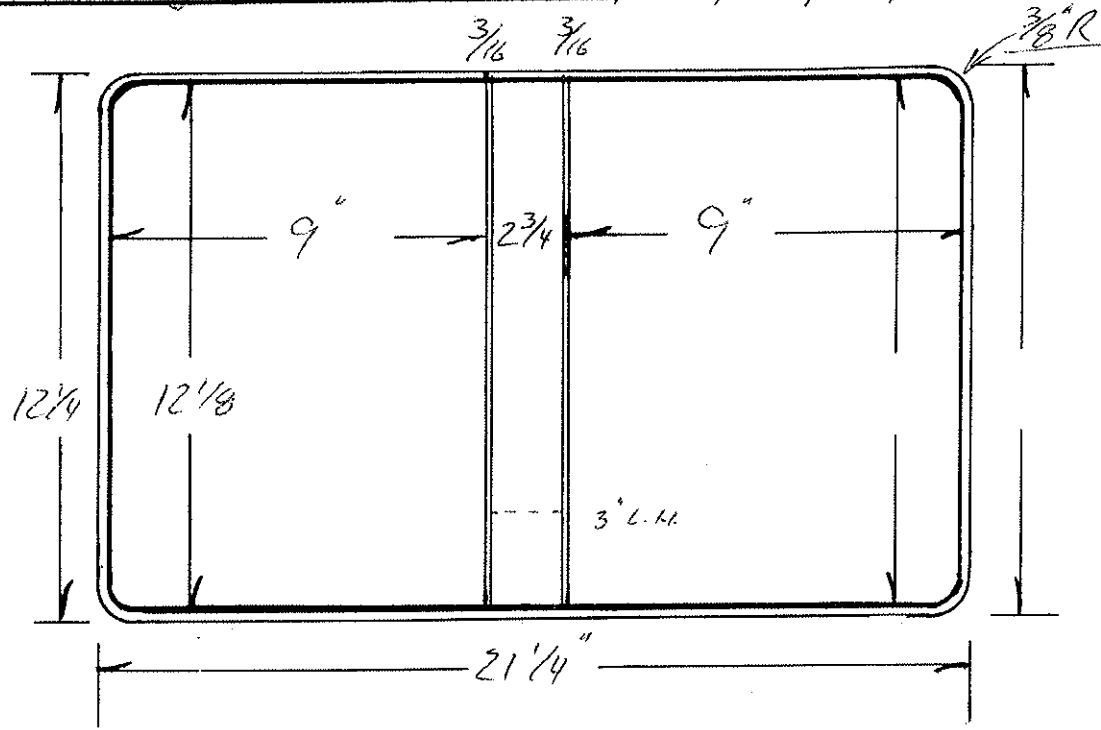

Code	Ga.	#	Cutting Specs		Code	Ga.	#	Cutting Specs						
			Size	Out				Size	Out					
Cover Mat.			13	X	22	15	1	Lining Mat.		13	X	22	15	1
Cover Mat.				X				Lining Mat.			X			
Vert. Pckt.				X				Horz. Pckt.			X			
Vert. Pckt.				X				Horz. Pckt.			X			
Pocket				X				Pocket			X			
Label Holder			3 3/8	X	4"	8	1	Card Holder			X			
Material				X				Material			X			
Material				X				Material			X			
Material				X				Material			X			
F.C. Board			12 1/16	X	8 15/16	100	1	B.C. Board			X			
B.C. Board			12 1/16	X	8 15/16	100	1	B.B. Board		12 1/16	X	2 2/32	100	1
Center Board				X				Board			X			
Board				X				Strip			X			
Cover Pad				X				Strip			X			
								B.B. Pad			X			

Customer	<u>JIMS JUNCTION</u>	
Metal		
Total Vinyl		
Quantity	<u>500</u>	
Date	<u>7-21-84</u>	
Type Corners	<u>RNO</u>	
Radius	<u>3/8"</u>	
Completed		

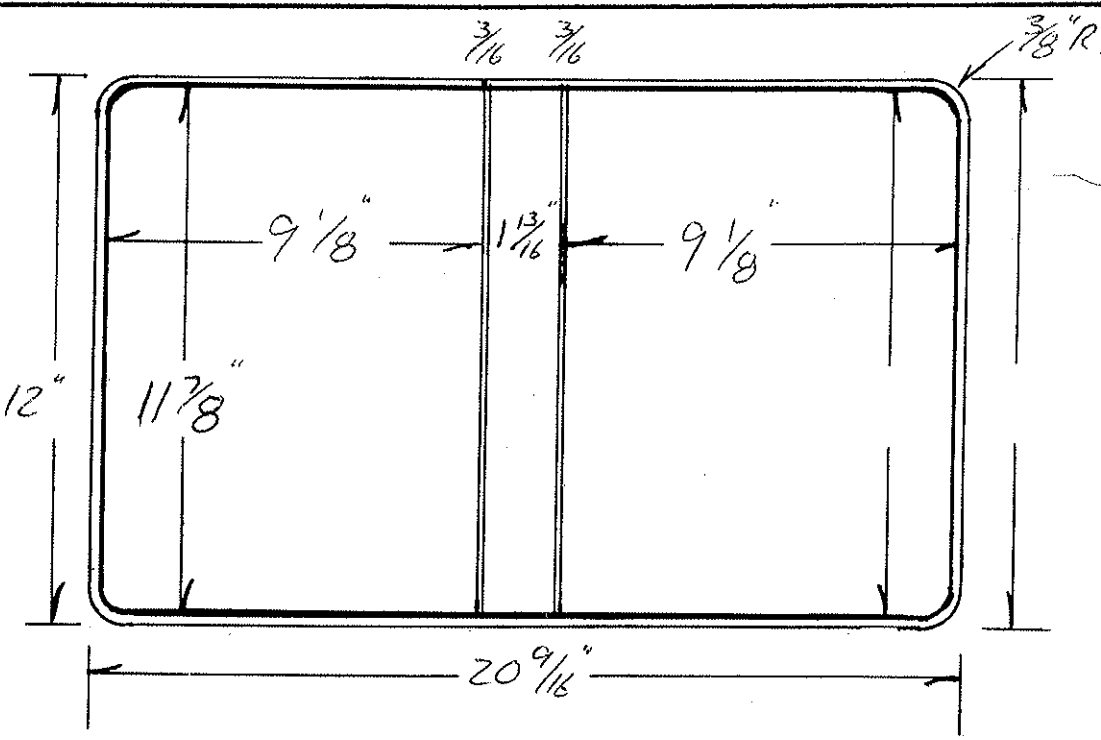

	Gauge	Thick
Tear Seal	<u>.016"</u>	<u>3/32</u>
Bar Seal	<u>*178</u>	<u>3/16"</u>
Bar Seal		

	No. of Feet
Tear Seal	
Bar Seal	
Bar Seal	

Code	Ga.	# PCS	Cutting Specs		Code	Ga.	# Pcs.	Cutting Specs	
			Size	# Out				Size	# Out
Cover Mat.					Lining Mat.				
			<u>12 3/4 X 21 3/8</u>					<u>12 3/4 X 21 3/8</u>	
Cover Mat.			X		Lining Mat.			X	
Vert. Pckt.			X		Horz. Pckt.			X	
Vert. Pckt.			X		Horz. Pckt.			X	
Pocket			X		Pocket			X	
Label Holder			X		Card Holder			X	
Material			X		Material			X	
Material			X		Material			X	
Material			X		Material			X	
F.C. Board					B.C. Board			X	
			<u>11 13/16 X 9 1/16</u>	<u>100</u>				<u>100</u>	<u>1</u>
B.G. Board					B.B. Board			<u>11 13/16 X 1 27/32</u>	<u>100</u>
			<u>11 13/16 X 9 1/16</u>	<u>100</u>				<u>100</u>	<u>1</u>
Center Board			X		Board			X	
Board			X		Strip			X	
Cover Pad			X		Strip			X	
					B.B. Pad			X	

CSP1

Customer	
Metal	
Total Vinyl	
Quantity	500
Date	8-10-85
Type Corners	RND
Radius	3/8"
Completed	

	Gauge	Thick
Tear Seal	016	3/32
Bar Seal	#254	5/32"
Bar Seal		

	No. of Feet
Tear Seal	
Bar Seal	
Bar Seal	

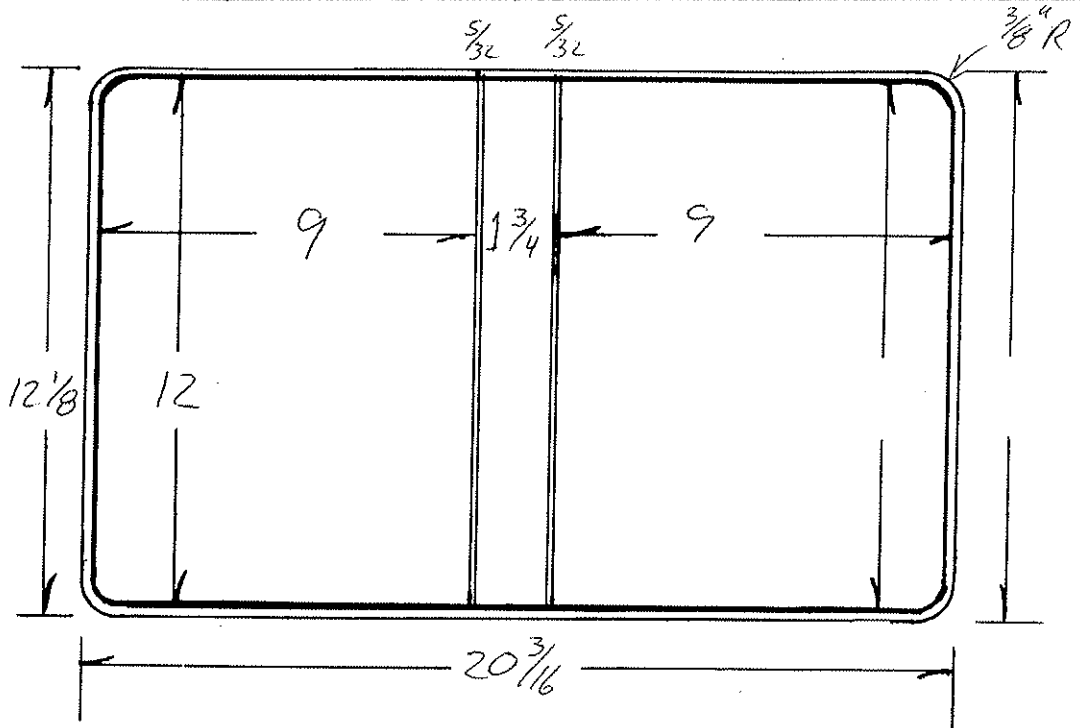

Code	Ga.	PCS	Cutting Specs		Code	Ga.	Pcs.	Cutting Specs	
			Size	Out				Size	Out
Cover Mat.		12 7/8 X 21	15	1	Lining Mat.		12 7/8 X 21	15	1
Cover Mat.		X			Lining Mat.		X		
Vert. Pckt.		X			Horz. Pckt.		X		
Vert. Pckt.		X			Horz. Pckt.		X		
Pocket		X			Pocket		X		
Label Holder		X			Card Holder		X		
Material		X			Material		X		
Material		X			Material		X		
Material		X			Material		X		
F.C. Board		11 5/16 X 8 15/16	100	1	B.C. Board		X		
B.C. Board		11 5/16 X 8 15/16	100	1	B.B. Board		11 5/16 X 1 25/32	100	1
Center Board		X			Board		X		
Board Det	4256	9 15/16 X 25 3/8		1/2	Strip		X		
Cover Pad		X			Strip		X		
					B.B. Pad		X		

MODERN HANDCRAFT

Customer

Metal
Total Vinyl
Quantity 300
Date 10-11-89
Type Corners
Radius $\frac{3}{8}$ "
Completed 10-13-89 RET

	Gauge	Thick
Tear Seal	.014	$\frac{1}{16}$
Bar Seal	#254	$\frac{3}{32}$ "
Bar Seal		

	No. of Feet
Tear Seal	
Bar Seal	
Bar Seal	

10-18-89

SIZE BY - BP ✓
CHECK BY - KP ✓

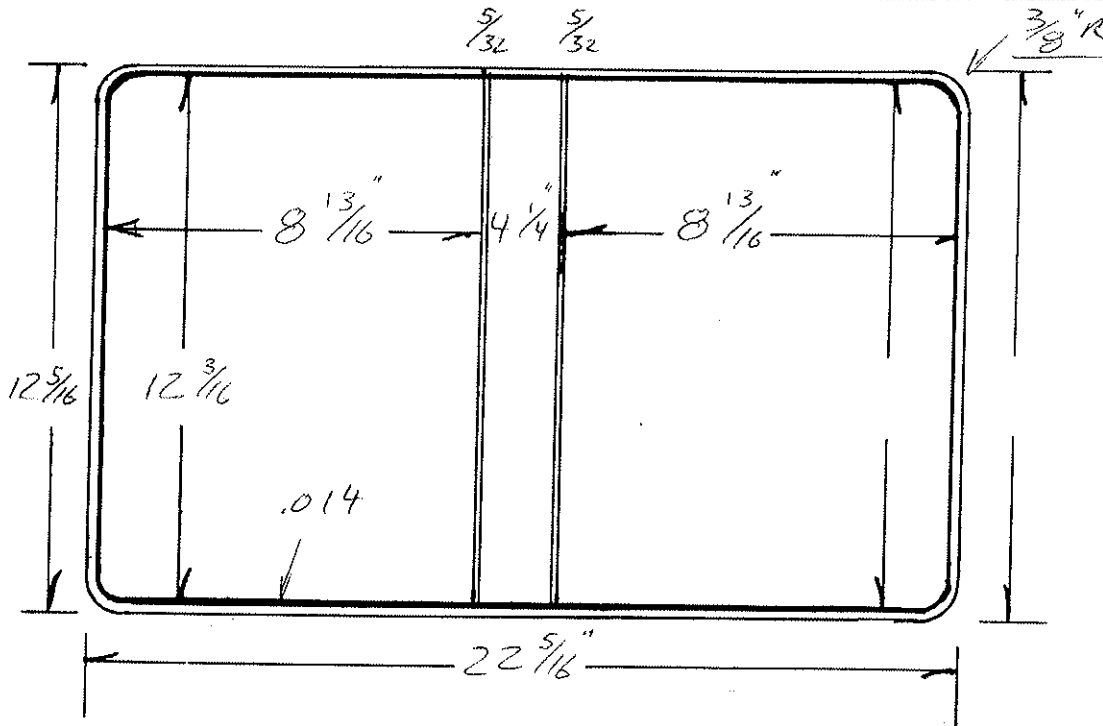

Code		Ga.	#	PCS	Size	Out	Cutting Specs		Code		Ga.	#	PCS	Size	Out	Cutting Specs	
Cover Mat.	$13 \frac{1}{8} \times 23 \frac{1}{8}$	15		1			Lining Mat.	$13 \frac{1}{8} \times 23 \frac{1}{8}$	15		1						
Cover Mat	X						Lining Mat.	X									
Vert. Pckt.	X						Horz. Pckt.	X									
Vert. Pckt.	X						Horz. Pckt.	X									
Pocket	X						Pocket	X									
Label Holder	X						Card Holder	X									
Material	X						Material	X									
Material	X						Material	X									
Material	X						Material	X									
F.C. Board	$12 \frac{1}{8} \times 8 \frac{3}{4}$	100		1			B.C. Board	X									
B.C. Board	$12 \frac{1}{8} \times 8 \frac{3}{4}$	100		1			B.B. Board	$12 \frac{1}{8} \times 4 \frac{5}{32}$	100		1						
Center Board	X						Board	X									
Board	X						Strip	X									
Cover Pad	X						Strip	X									
							B.B. Pad	X									
<p>cf individual Center use 101002 etc.</p>																	

Customer	BRYAN FOODS
Metal	
Total Vinyl	
Quantity	1000
Date	10-5-92
Type Corners	R2D
Radius	3/8
Completed	

BRYAN FOODS

10-23

	Gauge	Thick
Tear Seal	.014	1/16
Bar Seal	42.3	1/8
Bar Seal		

	No. of Feet
Tear Seal	
Bar Seal	
Bar Seal	

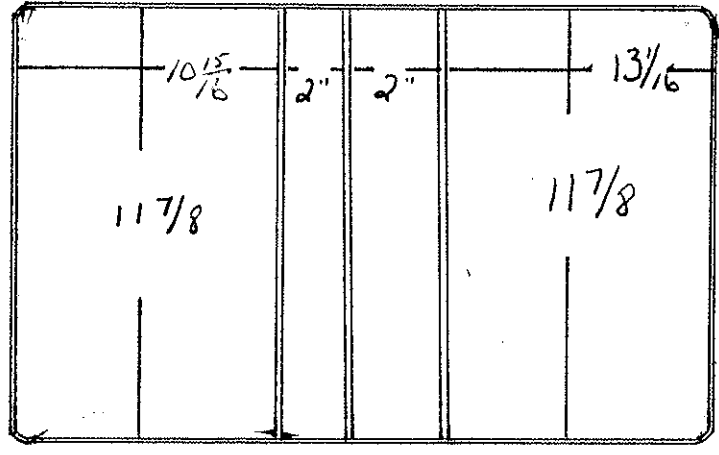

Tim

Code	Ga.	# PCS	Cutting Specs		Code	Ga.	# Pcs.	Cutting Specs	
			Size	Out				Size	Out
Cover Mat.		1	$12\frac{3}{4}$ X $17\frac{13}{16}$		Lining Mat.		1	$12\frac{3}{4}$ X $17\frac{13}{16}$	
Cover Mat. Clear		15	$12\frac{3}{4}$ X $11\frac{3}{8}$		Lining Mat.			X	
Vert. Pckt.			X		Horz. Pckt.			X	
Vert. Pckt.			X		Horz. Pckt.			X	
Pocket			X		Pocket			X	
Label Holder			X		Card Hlder			X	
Material			X		Material			X	
Material			X		Material			X	
Material			X		Material			X	
B.C. Board		48	$11\frac{3}{16}$ X 13	1	B.B. Board		100	$11\frac{3}{16}$ X $12\frac{29}{32}$	1
B.C. Board			X		B.B. Board		48	$11\frac{3}{16}$ X $12\frac{29}{32}$	1
Center Board			X		Board			X	
Board			X		Strip			X	
Cover Pad			X		Strip			X	
					B.B. Pad			X	

Customer	Northwestern Indiana Tele
Metal	
Total Vinyl	
Quantity	100
Date	12-7-97
Type Corners	RND
Radius	3/8
Completed	

Northwestern Indiana Tele 12-23

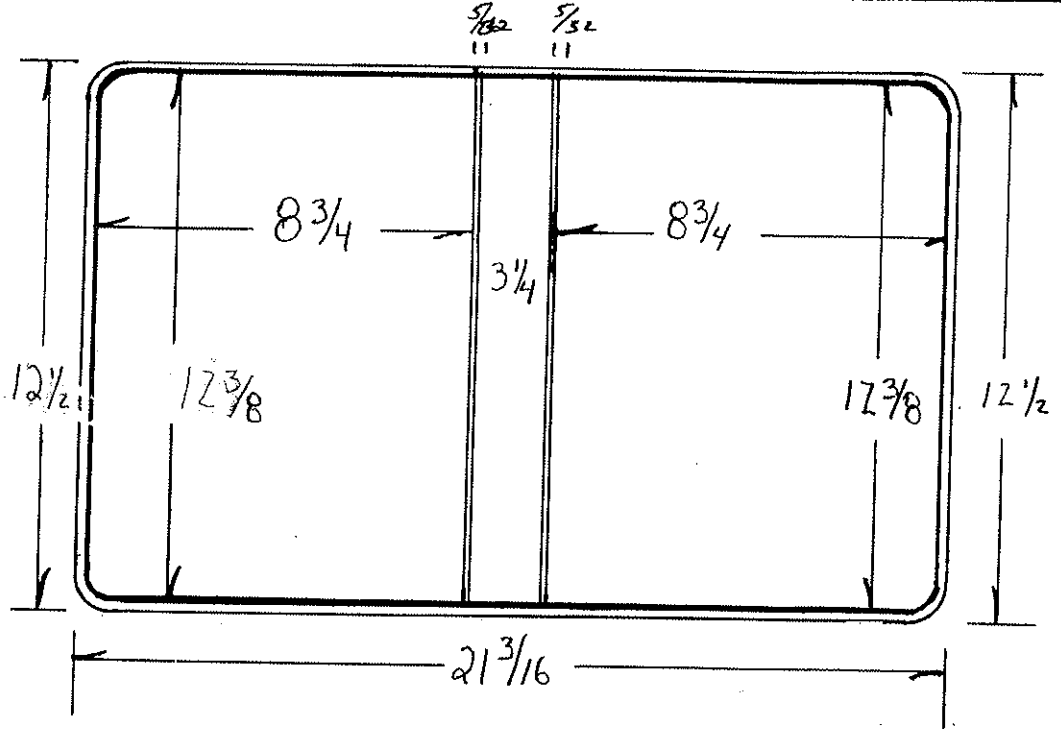

	Gauge	Thick
Tear Seal	.012	1/16
Bar Seal	1/84	5/32
Bar Seal		

	No. of Feet
Tear Seal	
Bar Seal	
Bar Seal	

T.M

Code	Ga.	#	Cutting Specs		Code	Ga.	#	Cutting Specs	
			Size	Out				Size	Out
Cover Mat.			13 1/4 X 22	1	Lining Mat.			13 1/4 X 22	1
Cover Mat			X		Lining Mat.			X	
Vert. Pckt.			X		Horz. Pckt.			X	
Vert. Pckt.			X		Horz. Pckt.			X	
Pocket			X		Pocket			X	
Label Holder			X		Card Holder			X	
Material			X		Material			X	
Material			X		Material			X	
Material			X		Material			X	
B.C. Board		100	12 5/16 X 8 1/16	1	B.C. Board			X	
B.C. Board		100	12 5/16 X 8 1/16	1	B.B. Board			X	
Center Board		100	12 5/16 X 3 5/32	1	Board			X	
Board			X		Strip			X	
Cover Pad			X		Strip			X	
					B.B. Pad			X	