

DIE #	2159-R	METAL	LOC - <i>Exposed</i>	RADIUS	
ORDER #	34965-4	CUSTOMER	JOES PIANO CO.	TEAR SEAL	.014
SHEET SIZE	8 1/2 X 11 1/2	STYLE CASE	VINYL PLATFORM EASEL	BAR SEAL	253-178
CAP.	1"	DUE DATE		COMPLETED	
LOCATION		QUANTITY	500	DATE	10-29-97

REVISION: 2159 WAS MADE IN TWO PIECES. *For Concealed Rivet*

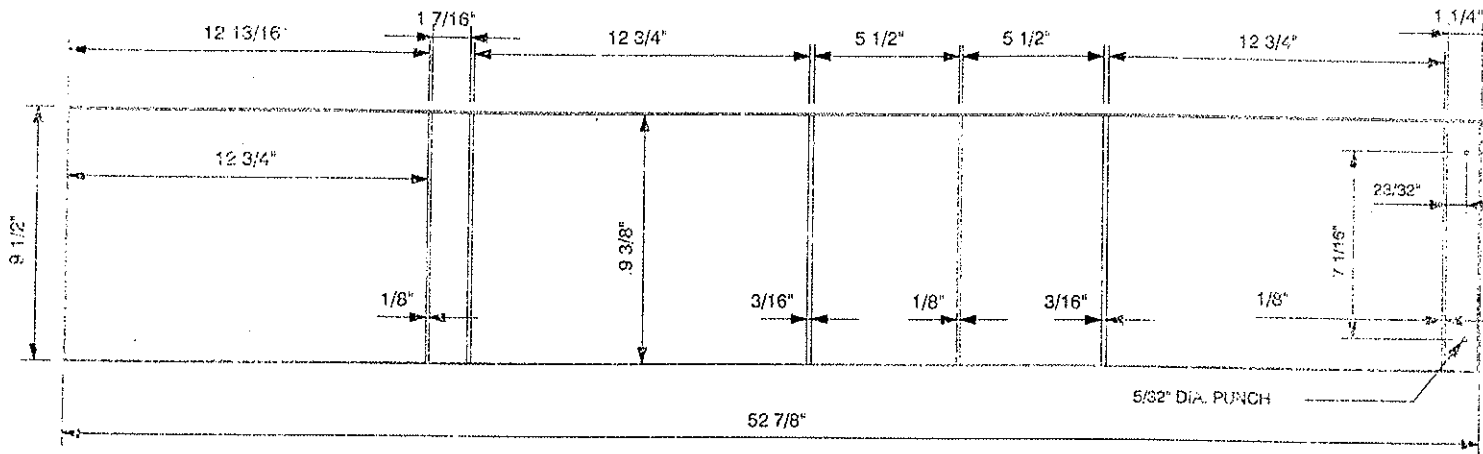

MATERIAL SPECS		GAUGE	PCS.	MATERIAL SPECS		GAUGE	PCS.
COVER MAT.	10 1/4 X 53 3/4		1	LINING MAT.	10 1/4 X 53 3/4		1
COVER MAT.				LINING MAT.			
DIE CUT				HORZ. PKT.			
COL	9 5/8 X 27 7/8		1	VERT. PKT.			
<del>LABEL HOLDER</del>	COL 9 5/8 X 14 7/8			DIE CUT			
GUSSET				REINF.			
BOARD SPECS		GAUGE	PCS.	BOARD SPECS		GAUGE	PCS.
F.C. BOARD	9 5/16 X 12 11/16		1	F.C. BOARD	9 5/16 X 12 11/16		1
B.B. BOARD	9 5/16 X 1 3/8		1	B.B. BOARD	9 5/16 X 5 13/32		2
B.C. BOARD	9 5/16 X 12 11/16		1	B.C. BOARD			
FLAP BD.	9 5/16 X 15 1/16		60 pt	DIE CUT	DIE CUT 2159-C		
BOARD	9 9/32 X 1 1/32		35	DIE CUT	22 X 13 3/4		1
						PADED FC-BB-BC	

Concealed Rivet

DIE #	2159	METAL	LOC	RADIUS	
ORDER #		CUSTOMER	JOES PIANO CO.	TEAR SEAL	.014
SHEET SIZE	8 1/2 X 11 1/2	STYLE CASE	VINYL PLATFORM EASEL	BAR SEAL	253-178
CAP.	1"	DUE DATE		COMPLETED	
LOCATION		QUANTITY	500	DATE	1-17-06

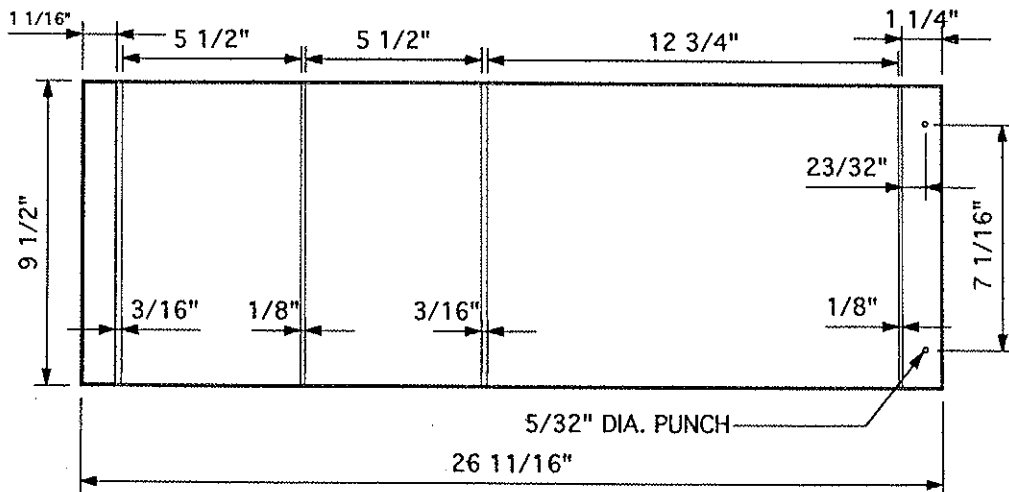
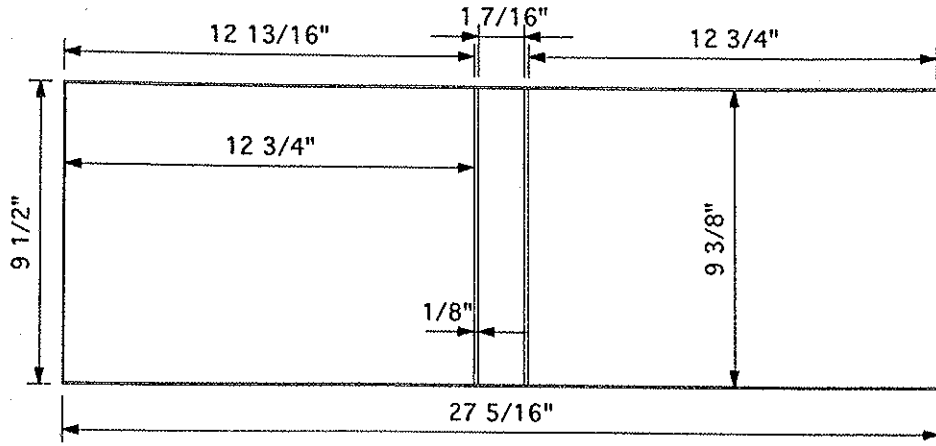

MATERIAL SPECS		GAUGE		MATERIAL SPECS		GAUGE	
COVER MAT.	10 1/4 X 28 1/8		1	LINING MAT.	10 1/4 X 28 1/8		1
COVER MAT.	10 1/4 X 27 1/2		1	LINING MAT.	10 1/4 X 27 1/2		1
DIE CUT				HORZ. PKT.			
COL	9 5/8 X 28 1/8		1	VERT. PKT.			
LABEL HOLDER	9 5/8 X 14 7/8			DIE CUT			
GUSSET				REINF.			

BOARD SPECS		GAUGE		BOARD SPECS		GAUGE	
F.C. BOARD	9 5/16 X 12 11/16		1	F.C. BOARD	9 5/16 X 12 11/16		1
B.B. BOARD	9 5/16 X 1 3/8		1	B.B. BOARD	9 5/16 X 5 13/32		2
B.C. BOARD	9 5/16 X 12 11/16		1	B.C. BOARD	9 5/16 X 7/8		1
FLAP BD.				DIE CUT			
BOARD	9 9/32 X 1 11/32	35		DIE CUT	DIE CUT 2159-C		
					22 X 13 3/4	PADDED FC-BR-BC	1

DIE #	3788-R	METAL	LOCK BOOSTER HOC	RADIUS	3/8"
ORDER #	981759	CUSTOMER	RALPH WILSON PLASTICS	TEAR SEAL	.016
SHEET SIZE	11 3/8 X 9 3/16	STYLE CASE	PLATFORM EASEL	BAR SEAL	254 (5/32)
CAP.	1 1/2	DUE DATE	7-7-95	COMPLETED	
LOCATION	K-3-9	QUANTITY	1500	DATE	6-19-95

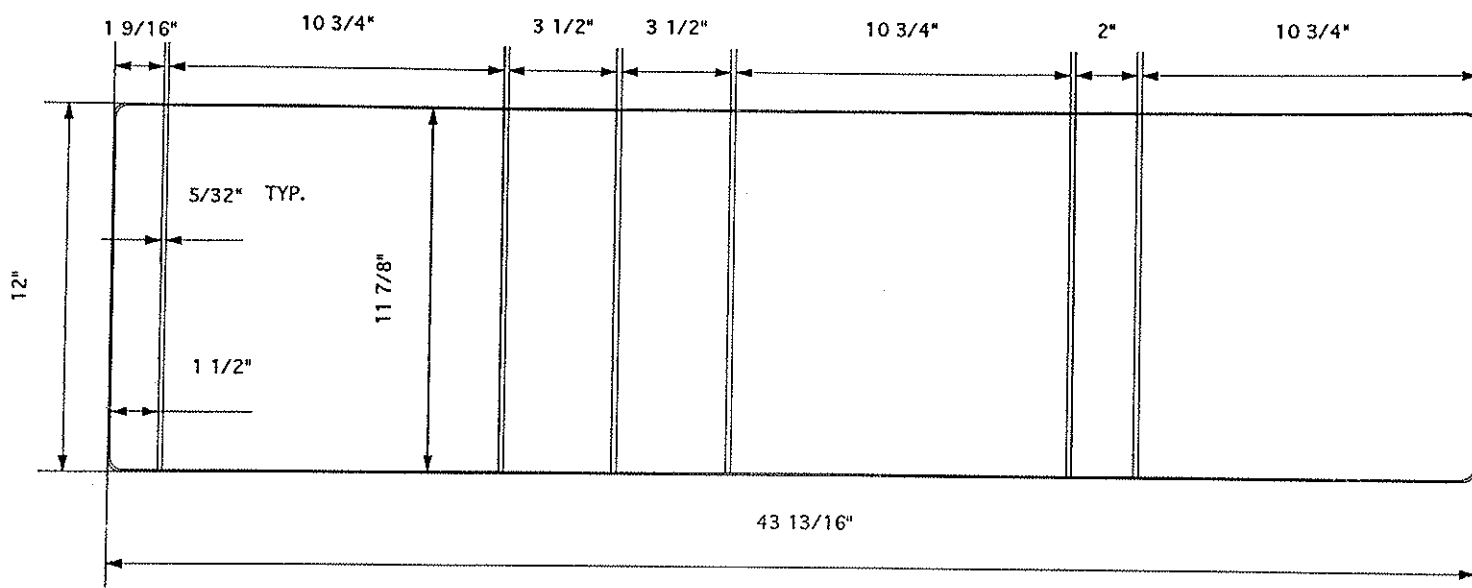

ALL BARS 5/32

MATERIAL SPECS		GAUGE		MATERIAL SPECS		GAUGE	
COVER MAT.	13 X 44 3/4		1	LINING MAT.	13 X 44 3/4		1
COVER MAT.				LINING MAT.			
DIE CUT				HORZ. PKT.			
COL EXEC.	12 1/4 X 13 7/16		1	VERT. PKT.			
LABEL HOLDER				DIE CUT			
GUSSET				REINF.			
BOARD SPECS		GAUGE		BOARD SPECS		GAUGE	
F.C. BOARD	11 25/32 X 10 21/32 RND	120	1	F.C. BOARD			
B.B. BOARD	11 25/32 X 1 29/32	120	1	B.B. BOARD			
B.C. BOARD	11 25/32 X 10 21/32 SQ.	120	2	B.C. BOARD			
B.U. STRIP				DIE CUT			
DIE CUT				DIE CUT			

DIE #	3888	METAL	1" ROUND RING	RADIUS	3/8
ORDER #	STOCK	CUSTOMER	STOCK	TEAR SEAL	.016
SHEET SIZE	11 X 9	STYLE CASE	PLATFORM EASEL	BAR SEAL	178
CAP.	1"	DUE DATE	metal Base Die 11/5/96	COMPLETED	
LOCATION		QUANTITY		DATE	6-9-95

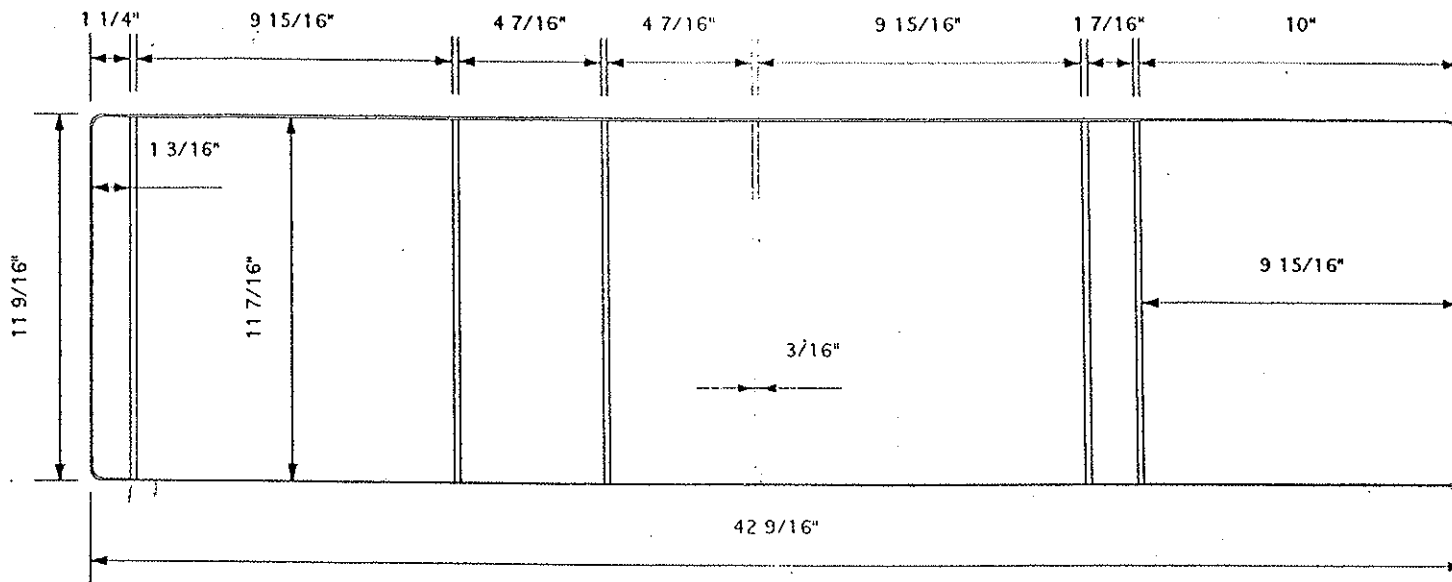

MATERIAL FIGURED 1" OVERALL FOR TEARSEAL DUE TO NUMBER OF BAR SEALS.

MATERIAL SPECS		GAUGE PCS.		MATERIAL SPECS		GAUGE PCS.	
COVER MAT.	12 1/4 X 43 5/8		1	LINING MAT.	12 1/4 X 43 5/8		1
COVER MAT.	12 9/16 X 43 5/8	(PADDED)	1	LINING MAT.	12 9/16 X 43 5/8	(PADDED)	1
FULL COL	11 11/16 X 43 5/8		1	HORZ. PKT.			
COL ON FC.	11 11/16 X 10 1/2		1	VERT. PKT.			
EX COL - FC-BB	11 11/16 X 13		1	DIE CUT			
COL - FC-BB-BC	11 11/16 X 22 7/16			REINF.			
BOARD SPECS		GAUGE PCS.		BOARD SPECS		GAUGE PCS.	
PANEL BDS.	11 3/8 X 9 7/8	100	3	PANEL BDS.	11 11/32 X 9 27/32		120
BB BDS.	11 3/8 X 1 11/32	100	1	B.B. BDS.	11 11/32 X 1 11/32 (033218)		120
BOARDS	11 1/4 X 1 7/32	35		BOARD			
FEET BD.	11 3/8 X 4 9/32	48	2	DIE CUT	12 3/8 X 21 3/16 (2 OUT)		
DIE CUT	(IF REQUESTED)	35		DIE CUT	(PADDED FC ONLY) 3888-B		

Padded Board FC-BB-BC 3888C  
14 1/8 x 20 1/8

Product Code

Style Case Platform

Sheet Size 8 1/2 x 11 1/2 Cap. 1 Die No. 4021 Order No. 1000180 Plate

Customer

Senate Computer Training Center

Metal
Total Vinyl .030
Quantity 2
Date
Type Corners <u>RD</u>
Radius <u>1/4 &amp; 3/32</u>
Completed

Gauge	Thick
Tear Seal .016	332
Bar Seal 253	18
Bar Seal	

No. of Feet	
Tear Seal	
Bar Seal	
Bar Seal	

1/4 RD  
↓

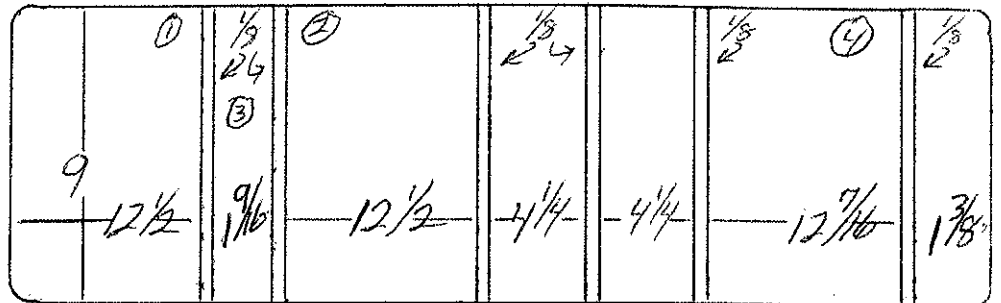

9 1/8  
1/4 RD  
↗

49 3/4

Code	Ga.	PCS	Cutting Specs		Code	Ga.	Pcs.	Cutting Specs	
			Size	Out				Size	Out
Cover Mat.			9 3/4	50 3/4	Lining Mat.			9 3/4	50 3/4
Cover Mat.			X		Lining Mat.			X	
Vert. Pckt.			9 3/4	12 5/8	Horz. Pckt.			X	
Vert. Pckt.			X		Horz. Pckt.			X	
Pocket			X		Pocket			X	
Label Holder			X		Card Holder			X	
Material			X		Material			X	
Material			X		Material			X	
Material			X		Material			X	
F.C. Board			8 29/32	12 13/32	B.C. Board				
B.C. Board			8 29/32	12 11/32	B.B. Board				
BB Center Board			8 29/32	15/32	Board			X	
Board Feet			8 29/32	4 5/32	Strip			X	
Cover Pad			X		Strip			X	
					B.B. Pad			X	

Product Code

Style Case 6 " Platform easel  
6 memo metal

Sheet Size 5 1/2 X 8 1/2 Cap. 1/2

Die No. 4087

Order No. 96047101

Plate

Customer

Chilton

Metal
Total Vinyl .030
Quantity 250
Date 10-10-88
Type Corners RD
Radius 1/4
Completed

	Gauge	Thick
Tear Seal	.016	3/32
Bar Seal	253	1/8
Bar Seal		

	No. of Feet
Tear Seal	
Bar Seal	
Bar Seal	

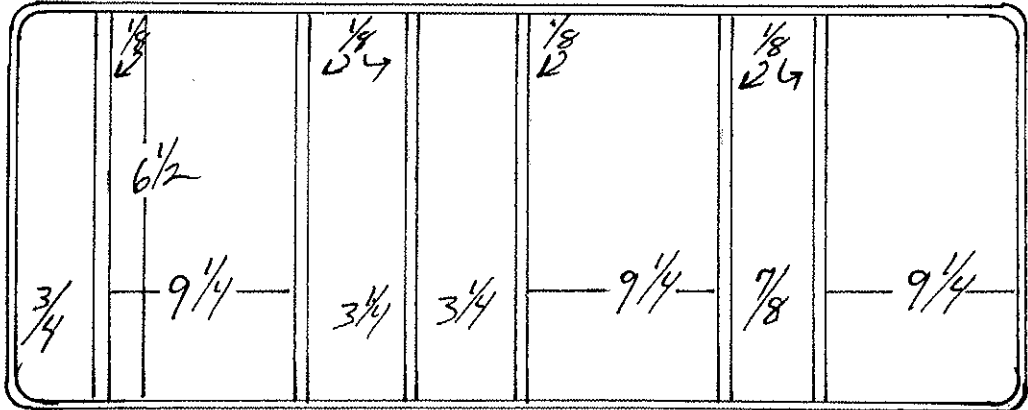

36 3/4

Code	Ga.	PCS	Cutting Specs		Code	Ga.	Pcs.	Cutting Specs	
			Size	Out				Size	Out
Cover Mat.		1	7 1/4 X 37 1/2		Lining Mat.	1	7 1/4 X 37 1/2		
Cover Mat.			X		Lining Mat.		X		
Vert. Pckt.			X		Horz. Pckt.		X		
Vert. Pckt.			X		Horz. Pckt.		X		
Pocket			X		Pocket		X		
Label Holder			X		Cardholder		X		
Material			X		Material		X		
Material			X		Material		X		
Material			X		Material		X		
F.C. Board		3	6 13/32 X 9 5/32		B.C. Board		X		
B.C. Board		1	6 13/32 X 2 5/32		B.B. Board		X		
Center Board		1	6 13/32 X 2 1/32		Board		X		
Board			X		Strip		X		
Cover Pad			X		Strip		X		
					B.B. Pad		X		

9/30/88

K.P.D.

STOEM

(PLATFORM CASE)

Product Code

Style Case HORIZONTAL TENT CASE

Sheet Size 11 x 9 Cap. 1/2 Die No. 4109

Order No. 961266 Plate

Customer DATA Resources

Metal
Total Vinyl
Quantity
Date 12-20-88
Type Corners RND
Radius 3/8"
Completed

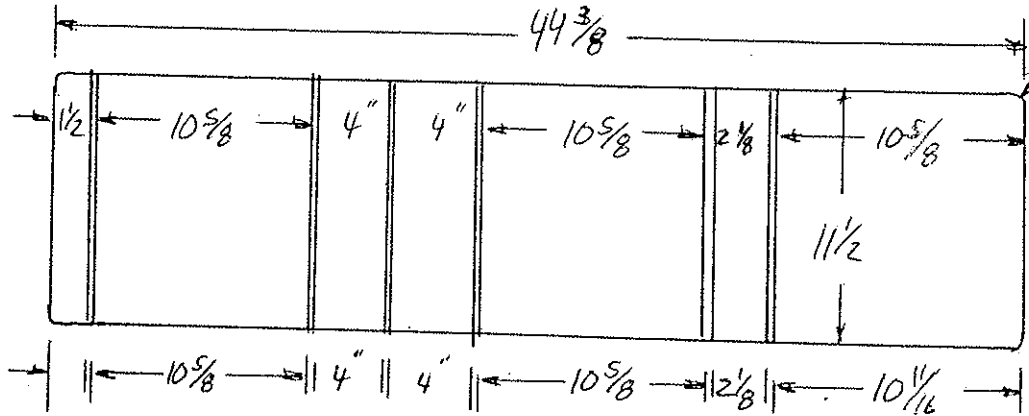

ALL BARS 1/8" - MTRL OVERSIZED DUE TO LENGTH

	Gauge	Thick
Tear Seal	16	3/32
Bar Seal	253	1/8
Bar Seal		

	No. of Feet
Tear Seal	
Bar Seal	
Bar Seal	

Code	Ga.	PCS	Cutting Specs		Code	Ga.	Pcs.	Cutting Specs.	
			Size	Out				Size	Out
Cover Mat.		1	12 1/4	45 3/8	Lining Mat.		1	12 1/4	45 3/8
Cover Mat. <i>Expanded</i>		1	12 5/8	46 3/8	Lining Mat. <i>expanded</i>		1	12 5/8	46 3/8
Vert. Pckt.			X		Horz. Pckt.			X	
Vert. Pckt.			X		Horz. Pckt.			X	
Pocket <i>COL FC-2-BB</i>			11 3/4	13 5/8	Pocket			X	
Label Holder <i>COL FC-2A-BC</i>			11 3/4	24 3/8	Card Hlder			X	
Material			X		Material			X	
Material			X		Material			X	
Material			X		Material			X	
F.C. Board <i>ROUND CORNER</i>		1	11 13/32	10 17/32	B.C. Board			X	
B.C. Board <i>SQUAN</i>		1	11 13/32	10 17/32	B.B. Board		1	11 13/32	2 1/32
Center Board <i>SQUAN</i>		1	11 13/32	10 17/32	Board			X	
Board For Feet		2	11 13/32	3 29/32	Strip			Padded FC-2-BB	
Cover Pad			X		Strip Die #4109B			15 x 12 3/8	
					B.B. Pad			Padded FC Only	

id # 4109c

Product Code

Style Case PLATFORM CASE C

Sheet Size 11 x 9 Cap. 1 1/4 Die No. 4211

Order No. 962585 Plate

Customer STANDARD PUBLISHING

Metal
Total Vinyl
Quantity 100
Date 5-15-87
Type Corners RND.
Radius 3/8"
Completed

Gauge	Thick
Tear Seal .016"	3/32"
Bar Seal	7/32"
Bar Seal	

No. of Feet
Tear Seal
Bar Seal
Bar Seal

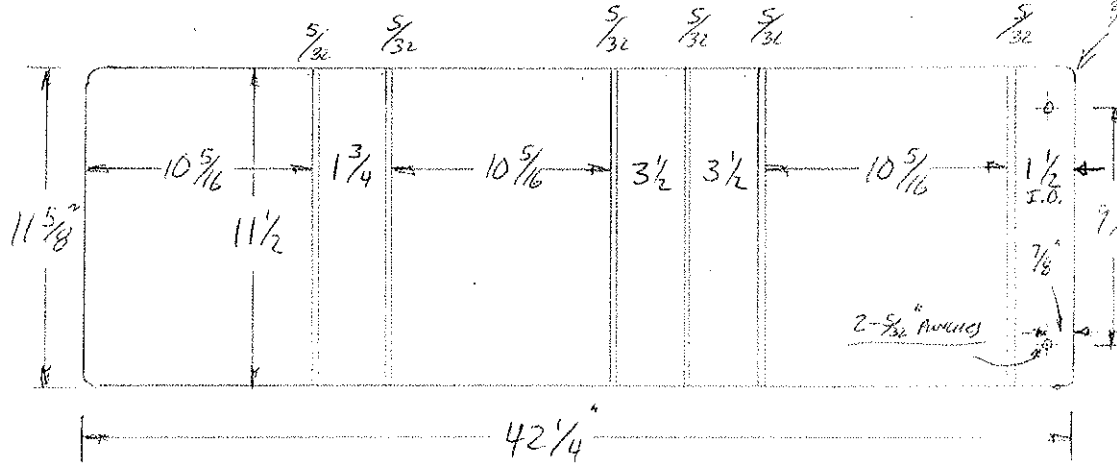

\* MTRL IS OVERSIZED DUE TO DIE LENGTH.

Code	Ga.	# PCS	Cutting Specs		Code	Ga.	# Pcs.	Cutting Specs	
			Size	# Out				Size	# Out
Cover Mat.		12 1/4 x 43 1/2	15	1	Lining Mat.		12 1/4 x 43 1/2	15	1
Cover Mat		X			Lining Mat.		X		
Vert. Pckt.		X			Horz. Pckt.		X		
Vert. Pckt.		X			Horz. Pckt.		X		
Pocket		X			Pocket		X		
Label Holder		X			Card Holder		X		
Material		X			Material		X		
Material		X			Material		X		
Material		X			Material		X		
F.C. Board		11 1/32 x 10 7/32	100	1	B.C. Board		X		
B.C. Board		11 1/32 x 10 7/32	100	1	B.B. Board		11 1/32 x 1 2 1/2	100	1
Center Board		11 1/32 x 10 7/32	100	1	Board		X		
Board		X			Strip		X		
Cover Pad		X			Strip		X		
					B.B. Pad		X		



Stock

Product Code \_\_\_\_\_ Style Case Platform Easel  
 Sheet Size 11 X 9 Cap. 1/2 Die No. 4447 Order No. 965717.1 Plate

DIGITAL

Customer
Metal
Total Vinyl
Quantity
Date
Type Corners
Radius
Completed

	Gauge	Thick
Tear Seal	.014	1/16"
Bar Seal	#253	5/32"
Bar Seal		

	No. of Feet
Tear Seal	
Bar Seal	
Bar Seal	

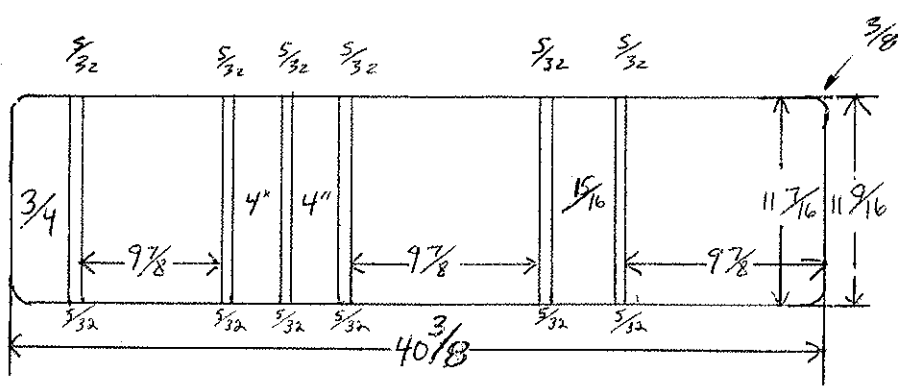

check by: *Dr*  
*PPW*

Code		Ga.	PCS	Size	Out	Cutting Specs	Code		Ga.	Pcs.	Size	Out	Cutting Specs.
Cover Mat.	12 1/4 X 41 3/8	15	1				Lining Mat.	12 1/4 X 41 3/8	15	1			
Cover Mat	X						Lining Mat.	X					
Vert. Pckt.	X						Horz. Pckt.	X					
Vert. Pckt.	X						Horz. Pckt.	X					
Pocket	X						Pocket	X					
Label Holder	X						Card Holder	X					
Material	X						Material	X					
Material	X						Material	X					
Material	X						Material	X					
F.C. Board	11 1/32 X 9 29/32		1				B.C. Board	X					
B.C. Board	11 1/32 X 9 29/32		1				B.B. Board	11 1/32 X 27 1/32		1			
Center Board	11 1/32 X 9 29/32		1				Board	X					
Board	X						Strip	X					
Cover Pad	X						Strip	X					
							B.B. Pad	X					



# Stock

Product Code

Style Case VRB PLATFORM CASE

Sheet Size 11 x 9 Cap. 2 1/2 Die No. 5085 Order No. 972479 Plate K-5-8

Customer <u>STOCK - GATES RUBBER CORP</u>		
etal		
otal Vinyl		
Quantity	<u>25</u>	
Date	<u>6-9-92</u>	
Type Corners		
Radius		
Completed		
No. of Feet		
ear Seal	Gauge	Thick
ear Seal	<u>.014</u>	<u>1/16</u>
ear Seal	<u>48-4</u>	<u>1/8</u>
ear Seal		
ear Seal		
ear Seal		

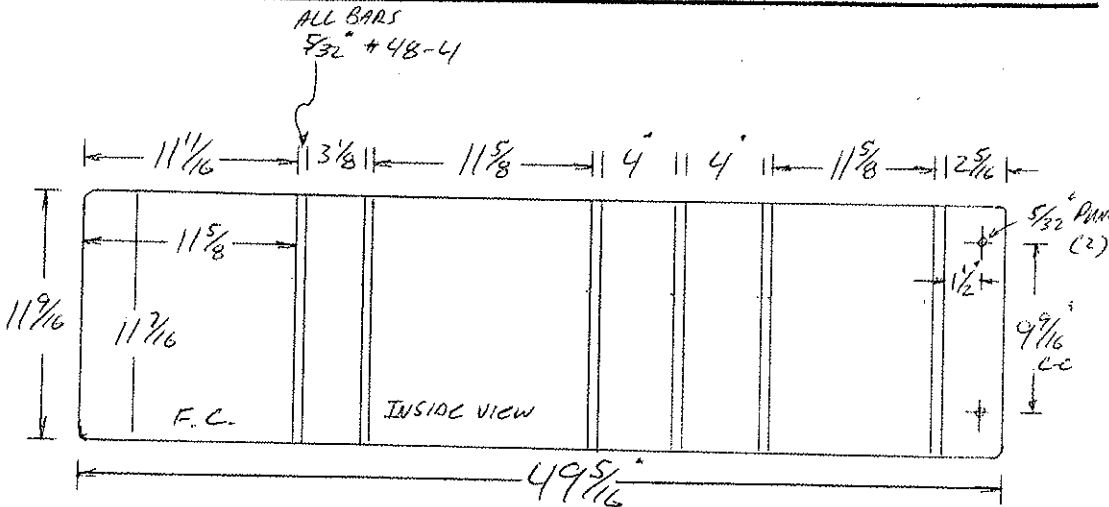

DWG. - B. Pace  
CHECK - R.P.V.

Code	Description	Ga.	# PCS	Cutting Specs		Code	Description	Ga.	# Pcs.	Cutting Specs	
				Size	Out					Size	Out
Over Mat.	<u>12 1/4 x 50 1/4</u>		<u>1</u>			Lining Mat.	<u>12 1/4 x 50 1/4</u>		<u>1</u>		
Over Mat.	X					Lining Mat.	X				
Art. Pckt.	X					Horz. Pckt.	X				
Art. Pckt.	X					Horz. Pckt.	X				
Pocket	X					Pocket	X				
Label Holder	X					Card Holder	X				
Material	<u>F.C. COG. 11 1/16 x 12 1/4</u>	<u>8</u>	<u>1</u>			Material	X				
Material	X					Material	X				
Material	X					Material	X				
B.C. Board	<u>R-C. 11 1/32 x 11 7/32</u>	<u>120</u>	<u>1</u>			B.C. Board	X				
B.C. Board	<u>SO. 11 1/32 x 11 7/32</u>	<u>120</u>	<u>1</u>			B.B. Board	<u>11 1/32 x 3 1/32</u>	<u>120</u>	<u>1</u>		
Enter Board	<u>SO. 11 1/32 x 11 7/32</u>	<u>120</u>	<u>1</u>			Board	X				
Board	X					Strip	X				
Over Pad	X					Strip	X				
						B.B. Pad	X				

Product Code

Style Case Platform Easel

Sheet Size 8 1/2 x 5 1/2 + 1/2 Cap. 1

Die No. 5241

Order No. 974160

Plate 1-11

Customer

Mercury Printing

D15-3

Material	
Total Vinyl	
Quantity	3000
Date	12-21-92
Type Corners	RND
Radius	3/8
Completed	

All Bars 1/8

32 1/8

Gauge	Thick
ear Seal	.014 1/16
ear Seal	.253 1/8
ear Seal	

No. of Feet	
ear Seal	
ear Seal	
ear Seal	

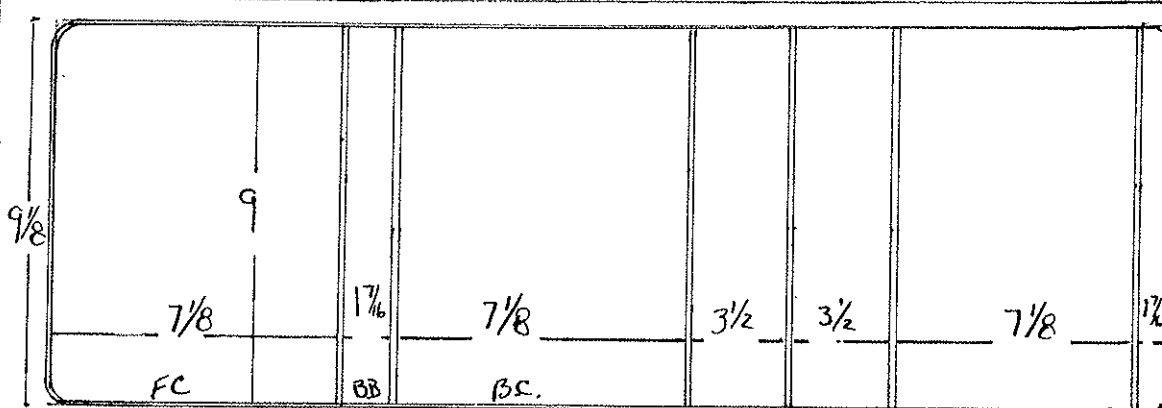

Tim

Code	Gauge	#	Cutting Specs		Code	Gauge	#	Cutting Specs	
			Size	Out				Size	Out
Cover Mat.		1	9 7/8	X 32 7/8	Lining Mat.		1	9 7/8	X 32 7/8
Cover Mat.				X	Lining Mat.				X
Front Pckt.				X	Horz. Pckt.				X
Front Pckt.				X	Horz. Pckt.				X
Locket				X	Pocket				X
Label Holder				X	Card Holder				X
Material				X	Material				X
Material				X	Material				X
Material				X	Material				X
C. Board	RND	100	8 15/16	X 7 1/16	B.C. Board				X
C. Board	Sq	100	8 15/16	X 7 1/16	B.B. Board				X
Inter Board	Sq	100	8 15/16	X 1 1/8	Board				X
Card	Sq	100	8 15/16	X 7 1/16	Strip				X
Cover Pad				X	Strip				X
					B.B. Pad				X

DIE #	5875	METAL	1" RR NB	RADIUS	3/8
ORDER #	71075	CUSTOMER	CLIMATE MASTER	TEAR SEAL	.014
SHEET SIZE	14 X 9 1/2	STYLE CASE	PLATFORM EASEL	BAR SEAL	178
CAP.	1"	DUE DATE	8-16-95	COMPLETED	
LOCATION		QUANTITY	100	DATE	7-21-95

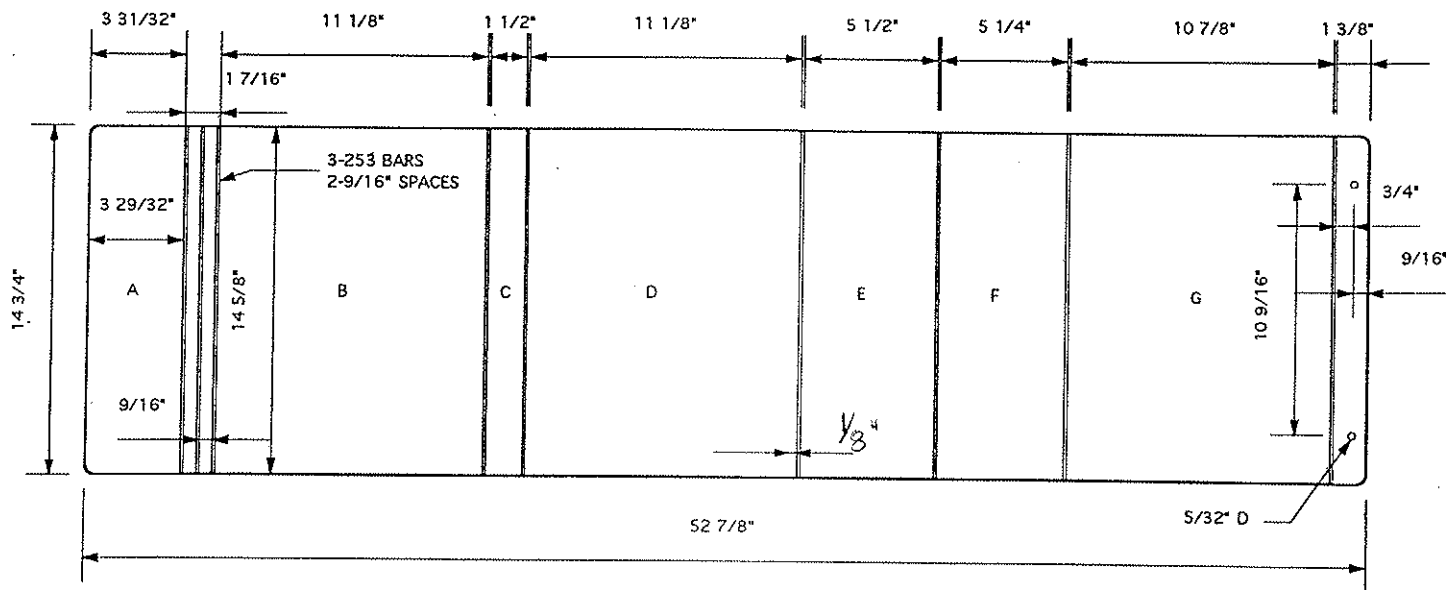

MATERIAL SPECS		GAUGE PCS.		MATERIAL SPECS		GAUGE PCS.	
COVER MAT.	15 1/2 X 54 1/2		1	LINING MAT.	15 1/2 X 54 1/2		1
COVER MAT.				LINING MAT.			
DIE CUT				HORZ. PKT.			
COL				VERT. PKT.			
LABEL HOLDER				DIE CUT			
GUSSET				REINF.			

BOARD SPECS		GAUGE PCS.		BOARD SPECS		GAUGE PCS.	
A BOARD	14 17/32 X 3 13/16	120	1	F BOARD	14 17/32 X 5 3/16	48	1
B BOARD	14 17/32 X 11 1/32	120	1	G BOARD	14 17/32 X 10 25/32	120	1
C BOARD	14 17/32 X 1 13/32	120	1	B.C. BOARD			
D BOARD	14 17/32 X 11 1/32	120	1	DIE CUT			
E BOARD	14 17/32 X 5 7/16	48	1	DIE CUT			

Stock

DIE #	5934	METAL	HOC	RADIUS	3/8
ORDER #	71849	CUSTOMER	J C BRADFORD	TEAR SEAL	.014
SHEET SIZE	11 X 9	STYLE CASE	PLATFORM EASEL	BAR SEAL	253
CAP.	2"	DUE DATE	11-8-95	COMPLETED	
LOCATION		QUANTITY	125	DATE	10-13-95

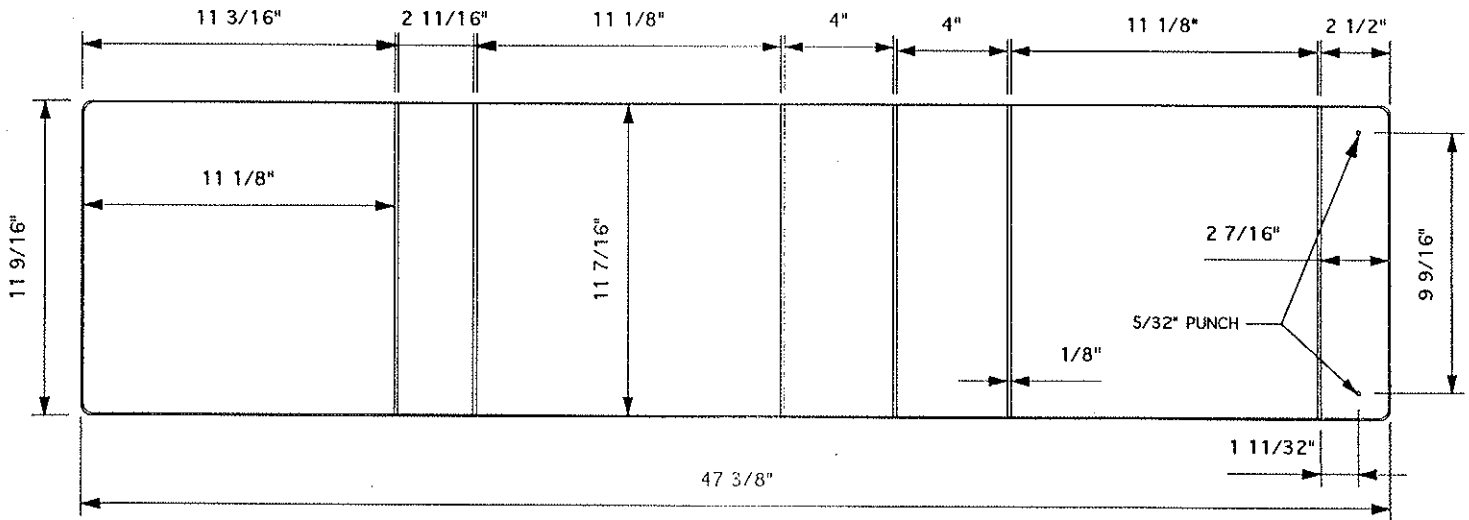

MATERIAL SPECS		GAUGE		PCS.		MATERIAL SPECS		GAUGE		PCS.	
COVER MAT.	12 1/4 X 48 3/8			1		LINING MAT.	12 1/4 X 48 1/8			1	
COVER MAT.						LINING MAT.					
DIE CUT						HORZ. PKT.					
COL						VERT. PKT.					
LABEL HOLDER						DIE CUT					
GUSSET						REINF.					

BOARD SPECS		GAUGE		PCS.		BOARD SPECS		GAUGE		PCS.	
BOARD	11 11/32 X 11 1/32	120	3			F.C. BOARD					
B.B. BOARD	11 11/32 X 2 19/32	120	1			B.B. BOARD					
B.C. BOARD	11 11/32 X 3 29/32			2		B.C. BOARD					
B.U. STRIP	11 11/32 X 2 13/32			1		DIE CUT					
DIE CUT						DIE CUT					

DIE #	6086	METAL	2 - 8, 1/2" NB ROUND RINGS	RADIUS	1/4"
ORDER #	984920	CUSTOMER	NIOXIN	TEAR SEAL	.014
SHEET SIZE	17 X 14 1/2	STYLE CASE	2 PC. VINYL PLATFORM EASEL	BAR SEAL	253
CAP.	1"	DUE DATE	7-11-96	COMPLETED	
LOCATION	G-4-8	QUANTITY	100	DATE	7-8-96

USE WITH DIE 6086-A

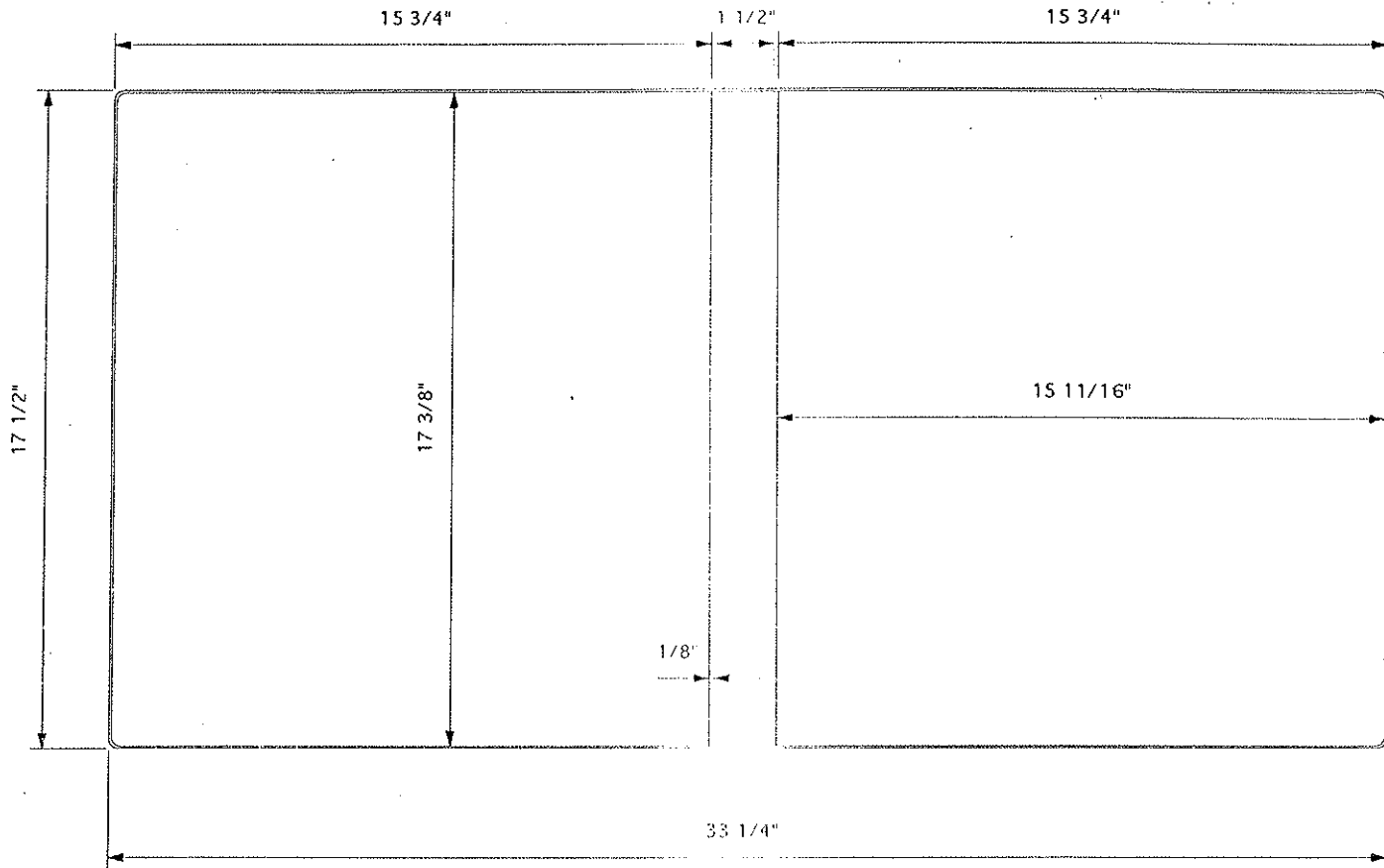

MATERIAL SPECS		GAUGE	PCS.	MATERIAL SPECS		GAUGE	PCS.
COVER MAT.	18 1/2 X 34 1/4		1	LINING MAT.	18 1/4 X 34		
COVER MAT.				LINING MAT.			
DIE CUT				HORZ. PKT.			
COL				VERT. PKT.			
LABEL HOLDER				DIE CUT			
GUSSET				REINF.			

BOARD SPECS			GAUGE	PCS.	BOARD SPECS			GAUGE	PCS.
PADDED BD	17 9/32 X 15 19/32		100	1	F.C. BOARD				
B.B. BOARD	17 9/32 X 1 13/32		100	1	B.B. BOARD				
B.C. BOARD	17 9/32 X 15 19/32		100	1	B.C. BOARD				
FLAP BD.					DIE CUT				
BOARD	17 1/4 X 1 5/16		22	1	DIE CUT				

DIE #	6115-A	METAL		RADIUS	1/4"
ORDER #	985322	CUSTOMER	COLOR GRAPHICS	TEAR SEAL	.014
SHEET SIZE	17 X 12 1/2	STYLE CASE	2 PC. PLATFORM EASEL	BAR SEAL	253
CAP.	1"	DUE DATE	9-19-96	COMPLETED	
LOCATION	L-5-5	QUANTITY	80	DATE	9-4-96

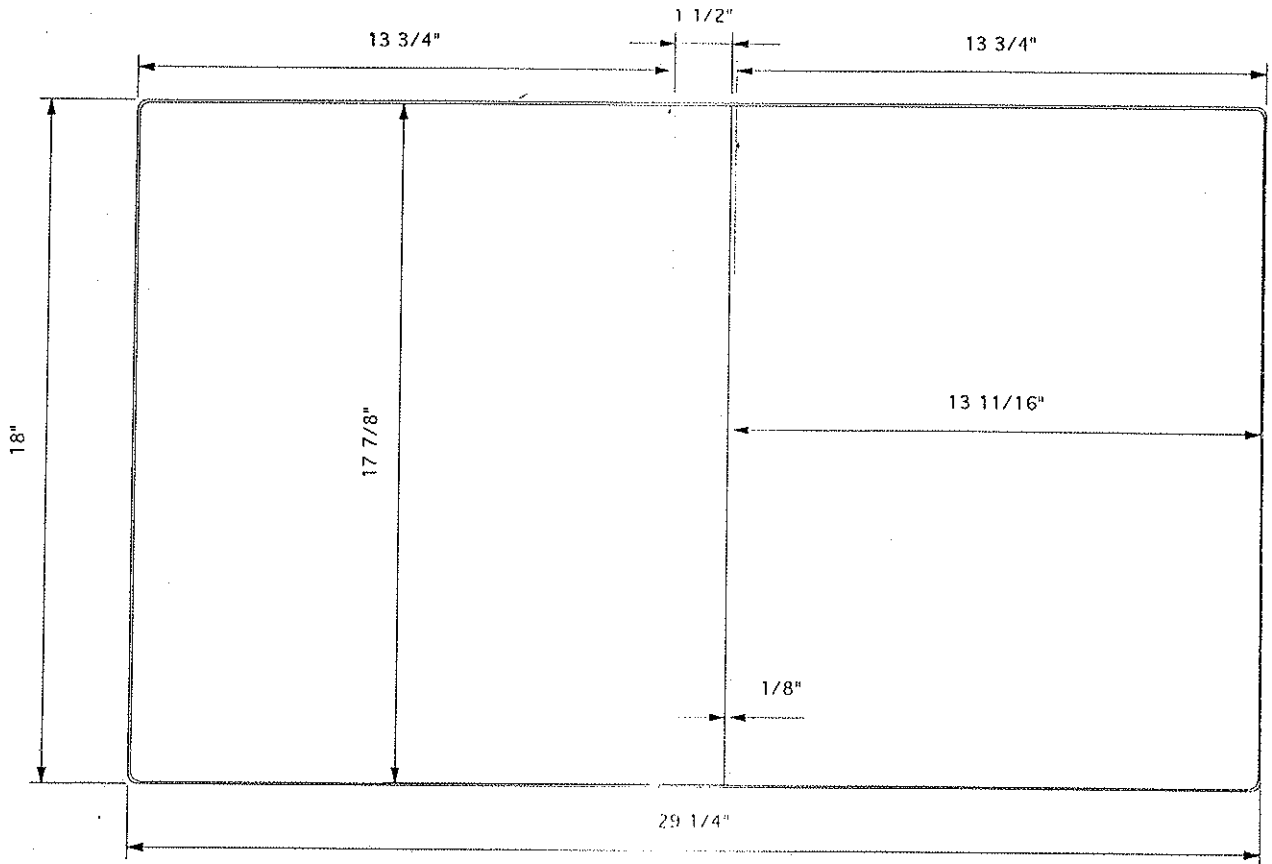

MATERIAL SPECS		GAUGE PCS.		MATERIAL SPECS		GAUGE P.	
COVER MAT.	18 3/4 X 30		1	LINING MAT.	18 3/4 X 30		
COVER MAT.				LINING MAT.			
DIE CUT				HORZ. PKT.			
COL				VERT. PKT.			
LABEL HOLDER				DIE CUT			
GUSSET				REINF.			

BOARD SPECS		GAUGE PCS.		BOARD SPECS		GAUGE P.	
F.C. BOARD	17 13/16 X 13 5/8	100	1	F.C. BOARD			
B.B. BOARD	17 13/16 X 1 13/32	100	1	B.B. BOARD			
B.C. BOARD	17 13/16 X 13 5/8	100	1	B.C. BOARD			
FLAP BD.				DIE CUT			
BOARD				DIE CUT			



DIE #	6250	METAL	LOC	RADIUS	3/8"
ORDER #	987159	CUSTOMER	ESTES EXPRESS LINES	TEAR SEAL	.012
SHEET SIZE	11 X 9	STYLE CASE	PLATFORM EASEL	BAR SEAL	48-3/253
CAP.	1"	DUE DATE	6-3-97	COMPLETED	
LOCATION	H-4-4	QUANTITY	50	DATE	5-21-97

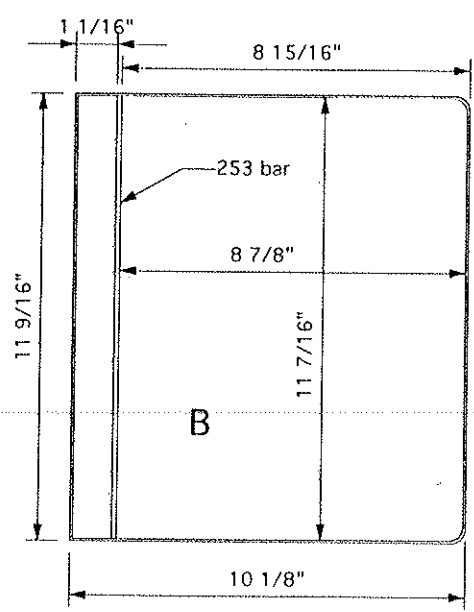
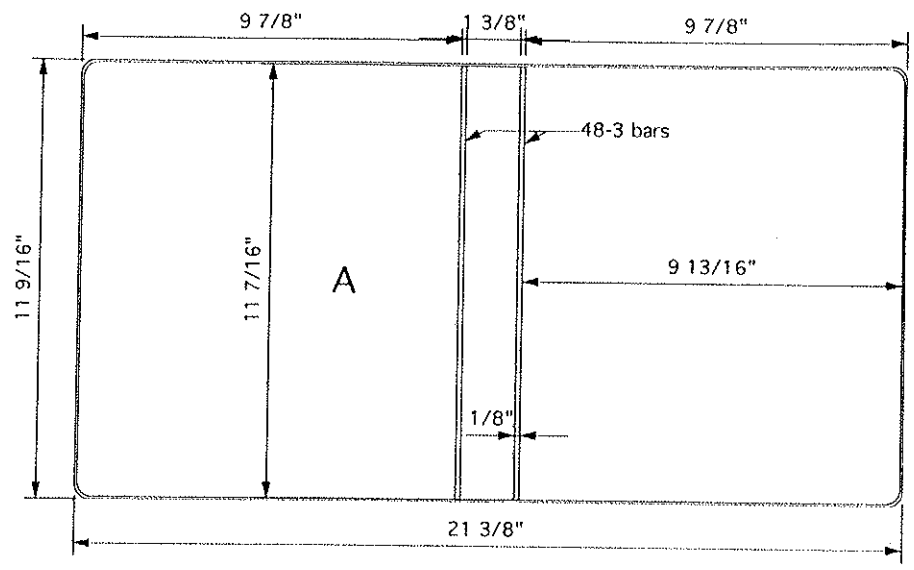

MATERIAL SPECS		GAUGE		MATERIAL SPECS		GAUGE	
COVER MAT.	12 5/16 X 22 1/8	6250-A	1	LINING MAT.	12 5/16 X 22 1/8	6250-A	1
COVER MAT.	12 5/16 X 10 7/8	6250-B	1	LINING MAT.	12 5/16 X 10 7/8	6250-B	1
DIE CUT				STRAP	6 1/2 X 1	FLAT CUT	1

A		BOARD SPECS		GAUGE		B		BOARD SPECS		GAUGE	
F.C. BOARD	11 3/8 X 9 3/4	120	1	F.C. BOARD	11 3/8 X 8 13/16	120	1	B.B. BOARD	11 3/8 X 31/32	120	1
B.B. BOARD	11 3/8 X 1 9/32	120	1	B.B. BOARD	11 3/8 X 31/32	120	1	B.C. BOARD			
B.C. BOARD	11 3/8 X 9 3/4	120	1	B.C. BOARD							

DIE #	6360	METAL	HOC ROUND	RADIUS	1/4"
ORDER #	76771	CUSTOMER	EBSCO MEDIA	TEAR SEAL	.014
SHEET SIZE	11 X 9	STYLE CASE	PLATFORM EASEL	BAR SEAL	254
CAP.	3"	DUE DATE	11-4-97	COMPLETED	
LOCATION	1-2-4	QUANTITY	950	DATE	10-23-97

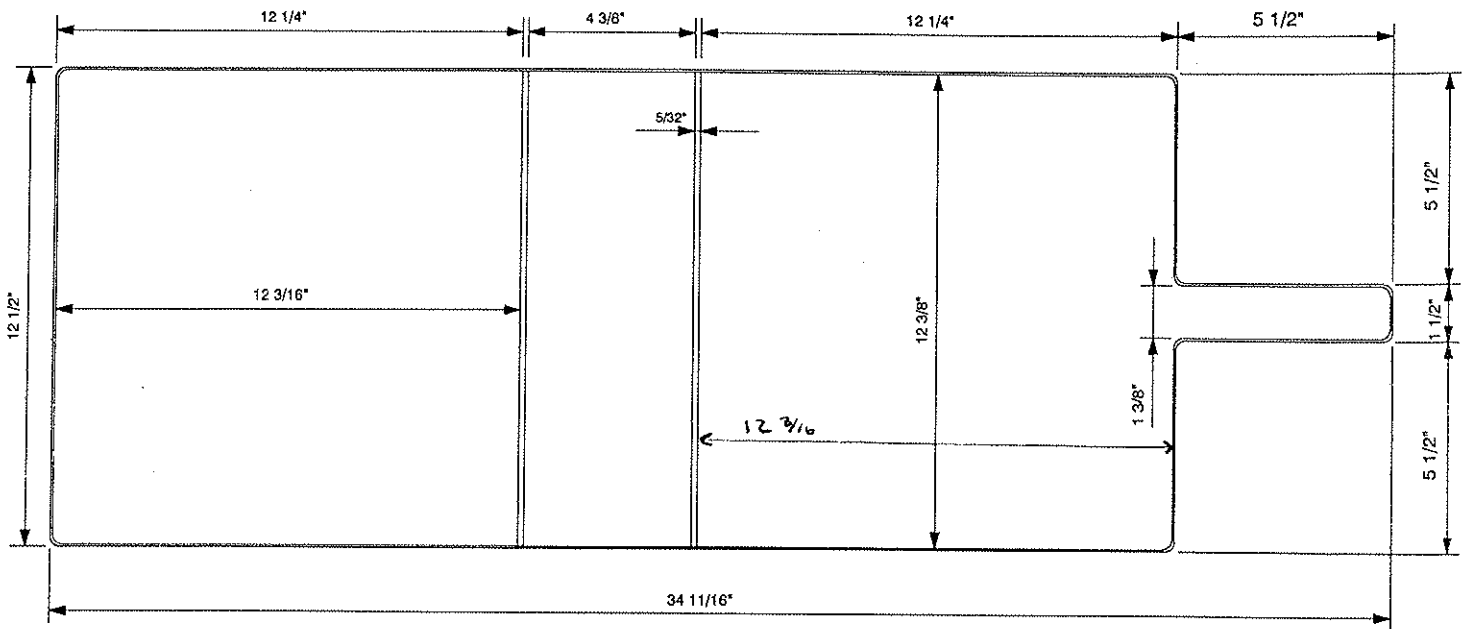

MATERIAL SPECS		GAUGE		MATERIAL SPECS		GAUGE	
COVER MAT.	13 1/4 X 35 1/2		1	LINING MAT.	13 1/4 X 35 1/2		1
COVER MAT.				LINING MAT.			
DIE CUT				HORZ. PKT.			
COL	12 11/16 X 18 3/8		1	VERT. PKT.			
LABEL HOLDER				DIE CUT			
GUSSET				REINF.			

BOARD SPECS		GAUGE		BOARD SPECS		GAUGE	
F.C. BOARD	12 5/16 X 12 1/8	120	1	F.C. BOARD			
B.B. BOARD	12 5/16 X 4 9/32	120	1	B.B. BOARD			
B.C. BOARD	12 5/16 X 12 1/8	120	1	B.C. BOARD			
FLAP BD.				DIE CUT			
BOARD				DIE CUT			

DIE #	6414 A-B	METAL	7 RING W/B	RADIUS	1/4"
ORDER #	988952	CUSTOMER	M K J MARKETING	TEAR SEAL	.010
SHEET SIZE	11 X 9	STYLE CASE	VINYL EASEL	BAR SEAL	A/48-4 B/254
CAP.	1"	DUE DATE	2-5-98	COMPLETED	
LOCATION	G-12-1 & 3	QUANTITY	150	DATE	1-13-98

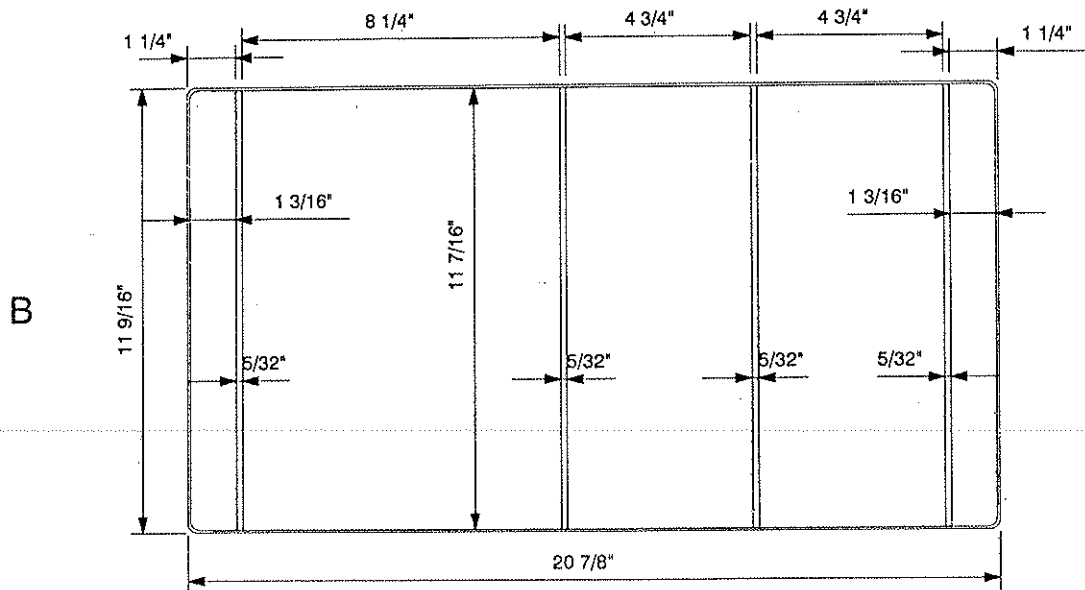
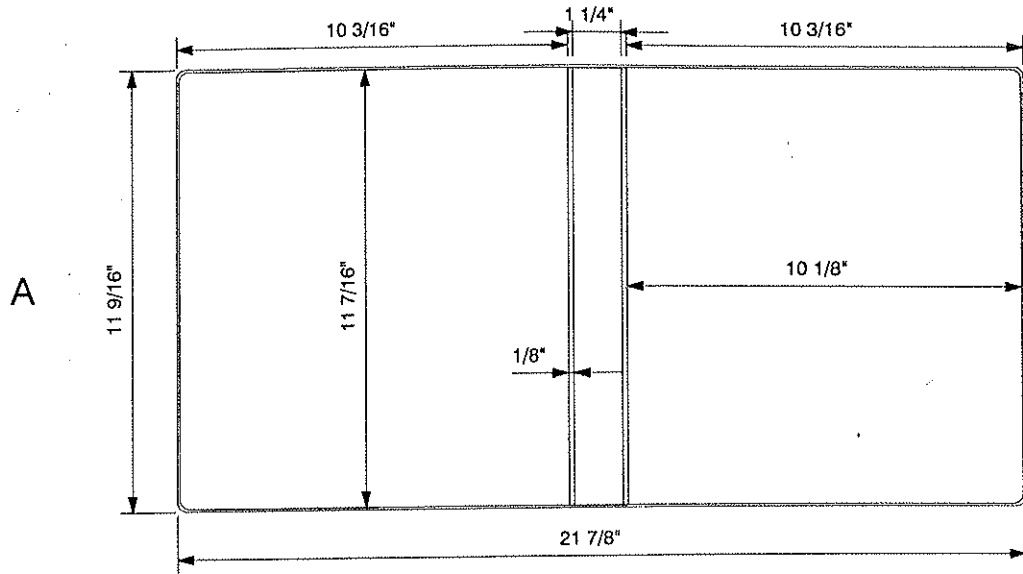

MATERIAL SPECS		GAUGE PCS.		MATERIAL SPECS		GAUGE	
COVER MAT.	12 5/16 X 22 5/8	A	1	LINING MAT.	12 5/16 X 22 5/8	A	
COVER MAT.	12 5/16 X 21 5/8	B	1	LINING MAT.	12 5/16 X 21 5/8	B	
DIE CUT				HORZ. PKT.			

BOARD SPECS A				BOARD SPECS B			
		GAUGE PCS.				GAUGE	
F.C. BOARD	11 3/8 X 10 1/16	100	1	BOARD	11 3/8 X 1	100	
B.B. BOARD	11 3/8 X 1 5/32	100	1	BOARD	11 3/8 X 8 3/16	100	
B.C. BOARD	11 3/8 X 10 1/16	100	1	BOARD	11 3/8 X 4 21/32	100	
BOARD				BOARD			

DIE #	6497-A	METAL	14" RR W/B	RADIUS	1/4"
ORDER #	989949	CUSTOMER	PRINT PROMOTIONS	TEAR SEAL	.010
SHEET SIZE	14 X 11 1/2	STYLE CASE	PLATFORM EASEL	BAR SEAL	253
CAP.	1"	DUE DATE	5-7-98	COMPLETED	
LOCATION	M-2-3	QUANTITY	1	DATE	5-7-98

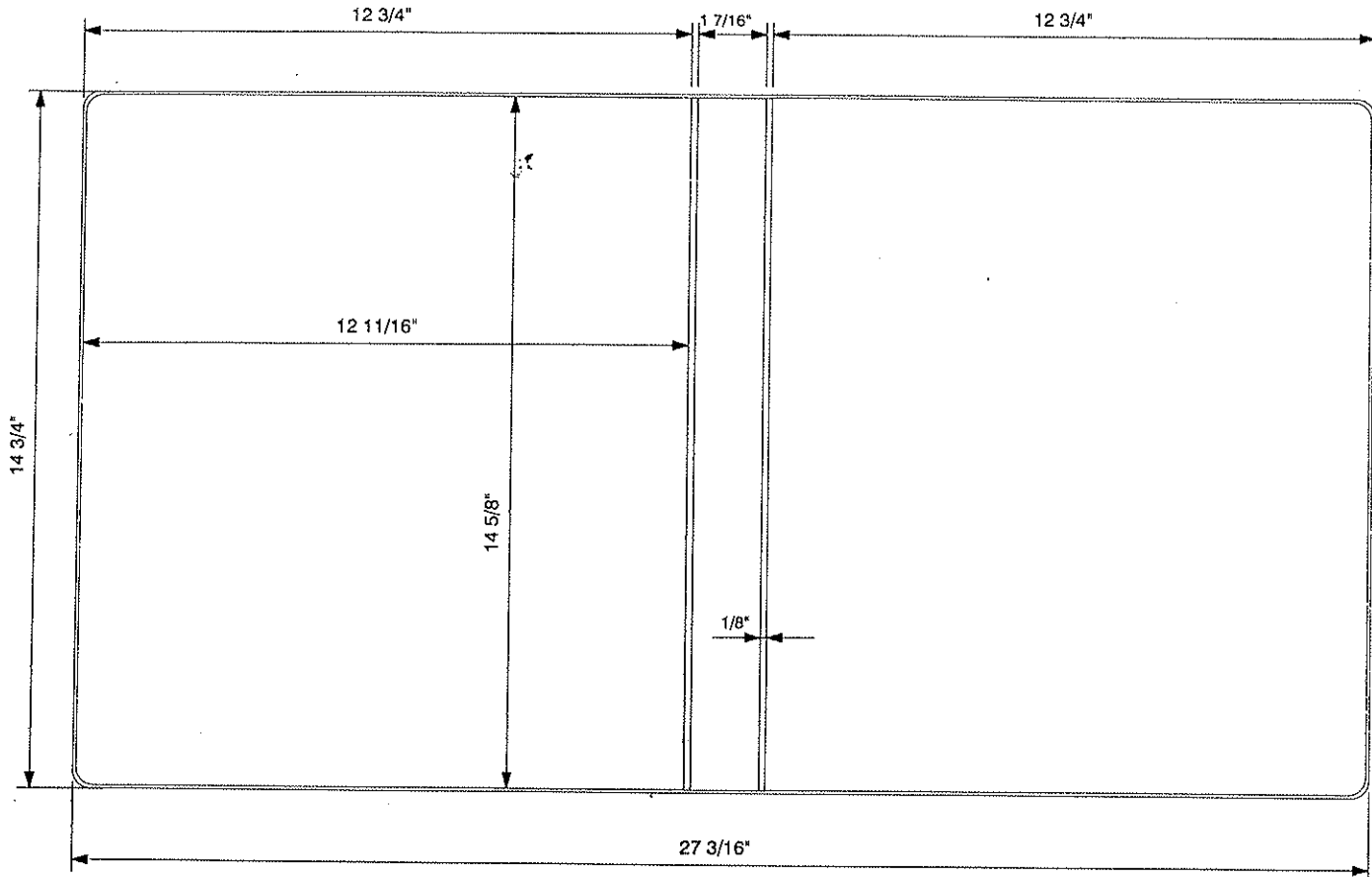

MATERIAL SPECS		GAUGE PCS.		MATERIAL SPECS		GAUGE PCS.	
COVER MAT.	15 3/4 X 28		1	LINING MAT.	15 3/4 X 28		1
COVER MAT.				LINING MAT.			
DIE CUT				HORZ. PKT.			
COL				VERT. PKT.			
LABEL HOLDER				DIE CUT			
GUSSET				REINF.			

BOARD SPECS		GAUGE PCS.		BOARD SPECS		GAUGE PCS.	
F.C. BOARD	14 17/32 X 12 19/32	100	1	F.C. BOARD			
B.B. BOARD	14 17/32 X 1 11/32	100	1	B.B. BOARD			
B.C. BOARD	14 17/32 X 12 19/32	100	1	B.C. BOARD			
FLAP BD.				DIE CUT			
BOARD				DIE CUT			

DIE #	6377-A	METAL	14" RR W/B	RADIUS	1/4"
ORDER #	988679	CUSTOMER	RADISSON CRUISE	TEAR SEAL	.010
SHEET SIZE	14 X 11	STYLE CASE	PLATFORM EASEL	BAR SEAL	253
CAP.	1"	DUE DATE	12-5-97	COMPLETED	
LOCATION	M-1-7	QUANTITY	25	DATE	11-25-9

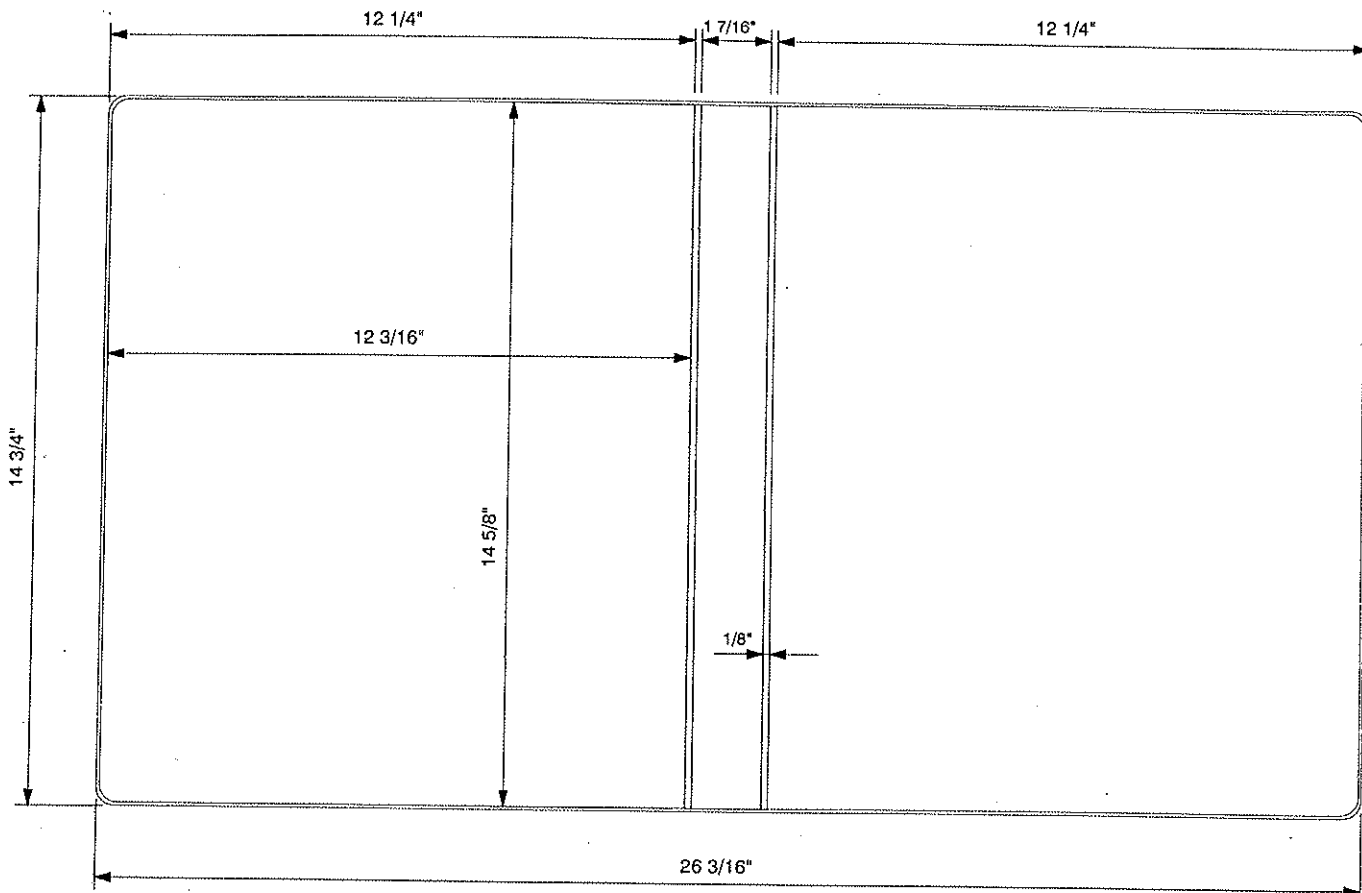

MATERIAL SPECS		GAUGE PCS.		MATERIAL SPECS		GAUGE	
COVER MAT.	15 3/4 X 27		1	LINING MAT.	15 3/4 X 27		
COVER MAT.	15 3/4 X 12 7/8		1	LINING MAT.			
DIE CUT				HORZ. PKT.			
COL				VERT. PKT.			
LABEL HOLDER				DIE CUT			
GUSSET				REINF.			

BOARD SPECS		GAUGE PCS.		BOARD SPECS		GAUGE	
F.C. BOARD	14 17/32 X 12 3/32	120	1	F.C. BOARD			
B.B. BOARD	14 17/32 X 1 11/32	120	1		3PC. PICTORIAL SIZE		
B.C. BOARD	14 17/32 X 12 3/32	120	1		14 1/2 X 12 1/16		
FLAP BD.				DIE CUT			
BOARD				DIE CUT			

DIE #	6530	METAL	STR D N/B	RADIUS	3/8"
ORDER #	78189	CUSTOMER	AMERICAN FREIGHTWAYS	TEAR SEAL	.012
SHEET SIZE	11.75 X 9.75	STYLE CASE	VINYL EASEL	BAR SEAL	253-178
CAP.	1 1/2"	DUE DATE	7-16-98	COMPLETED	
LOCATION	M-2-9	QUANTITY	750	DATE	6-24-98

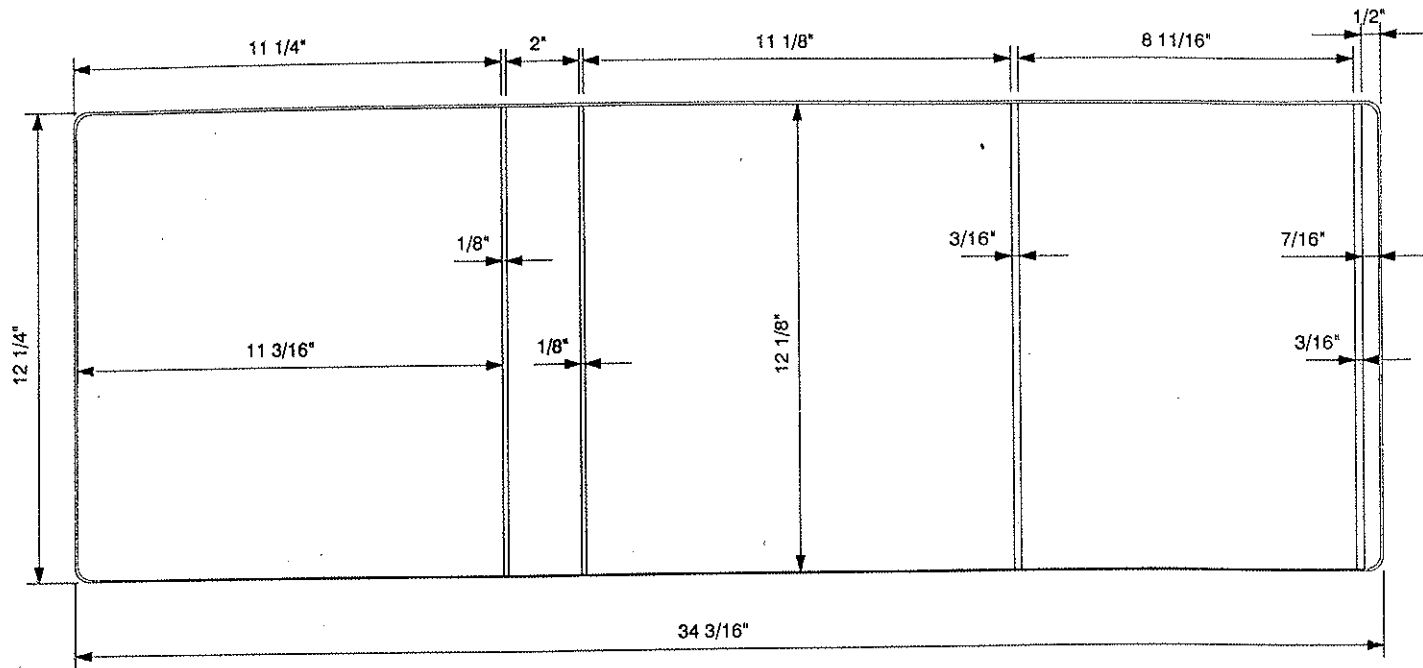

MATERIAL SPECS		GAUGE	PCS.	MATERIAL SPECS		GAUGE	PCS.				
COVER MAT.	13 X 35		1	LINING MAT.	13 X 35		1				
COVER MAT.				LINING MAT.							
DIE CUT				HORZ. PKT.							
COL				VERT. PKT.							
LABEL HOLDER				DIE CUT							
GUSSET				REINF.							
BOARD SPECS		5/16" R. CORNERS		GAUGE	PCS.	BOARD SPECS		5/16" R. CORNERS		GAUGE	PCS.
F.C. BOARD	12 1/16 X 11 1/8	100	1	F.C. BOARD							
B.B. BOARD	12 1/16 X 1 29/32	100	1	B.B. BOARD							
B.C. BOARD	12 1/16 X 11 1/16	100	1	B.C. BOARD							
FLAP BD.	12 1/16 X 8 5/8	100	1	DIE CUT							
BOARD	12 1/16 X 11/32	100	1	DIE CUT							

DIE #	6575 A-B	METAL	RR NB	RADIUS	1/4"
ORDER #	168567	CUSTOMER	RHONE POULENC RORER	TEAR SEAL	.012
SHEET SIZE	13.25 X 11	STYLE CASE	PLATFORM EASEL	BAR SEAL	254-178
CAP.	1 1/2"	DUE DATE	10-18-98	COMPLETED	
LOCATION		QUANTITY	600	DATE	9-30-98

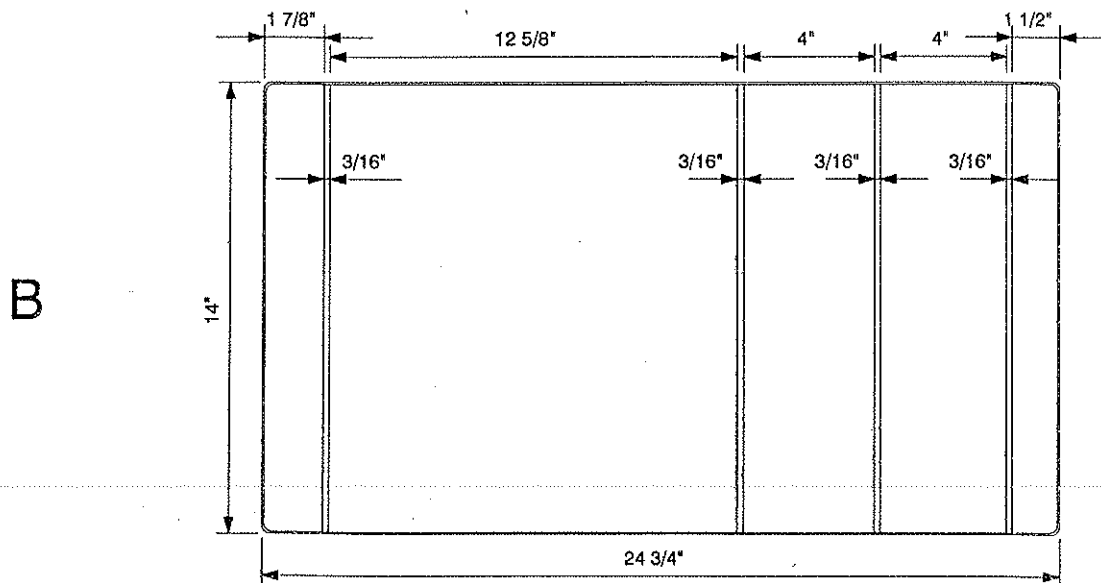
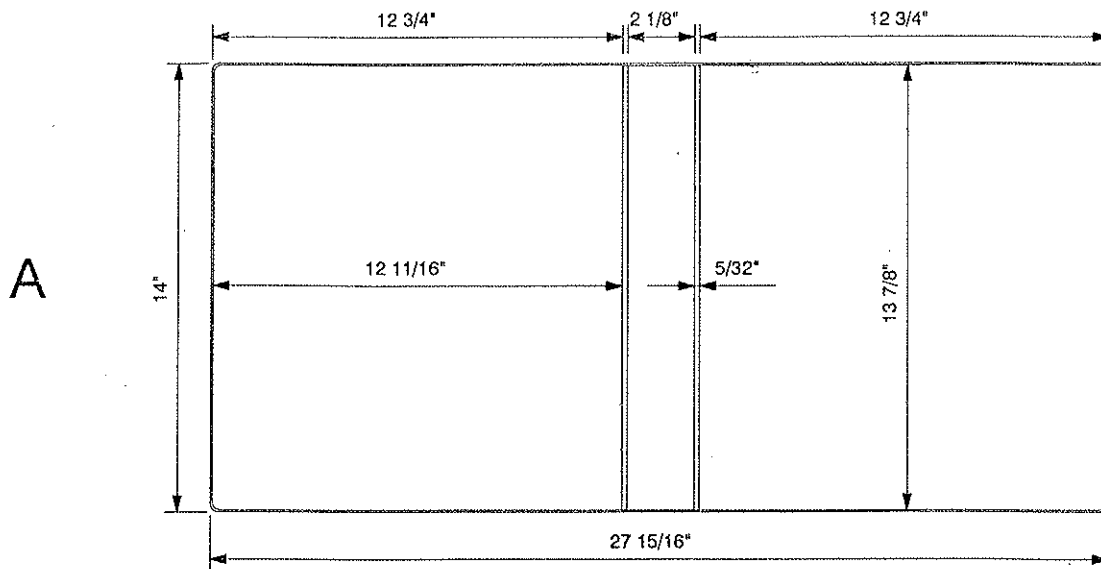

MATERIAL SPECS		GAUGE	PCS.	MATERIAL SPECS		GAUGE	PCS.
COVER MAT.	14 3/4 X 28 3/4	A	1	LINING MAT.	14 3/4 X 28 3/4	A	1
COVER MAT.	14 3/4 X 25 1/2	B	1	LINING MAT.	14 3/4 X 25 1/2	B	1
DIE CUT				HORZ. PKT.			

BOARD SPECS		5/16" R. CORNERS		GAUGE	PCS.	BOARD SPECS		5/16" R. CORNERS		GAUGE	PCS.
F.C. BOARD	13 13/16 X 12 5/8	A	100	1	BOARD	13 13/16 X 12 9/16	B	100	1		
B.B. BOARD	13 13/16 X 2 1/32	A	100	1	BOARD	13 13/16 X 3 29/32	B	100	2		
B.C. BOARD	13 13/16 X 12 5/8	A	100	1	BOARD	13 13/16 X 1 11/32	B	100	1		
FLAP BD.					DIE CUT						
BOARD					DIE CUT						

DIE #	6589-A	METAL	2 - NB ROUND RINGS	RADIUS	1/4
ORDER #	176276	CUSTOMER	LITHO INDUSTRIES	TEAR SEAL	.012
SHEET SIZE	17 X 11 1/2	STYLE CASE	VINYL PLATFORM EASEL	BAR SEAL	253
CAP.	1"	DUE DATE	11-12-98	COMPLETED	
LOCATION	A-17-5	QUANTITY	700	DATE	10-27-98

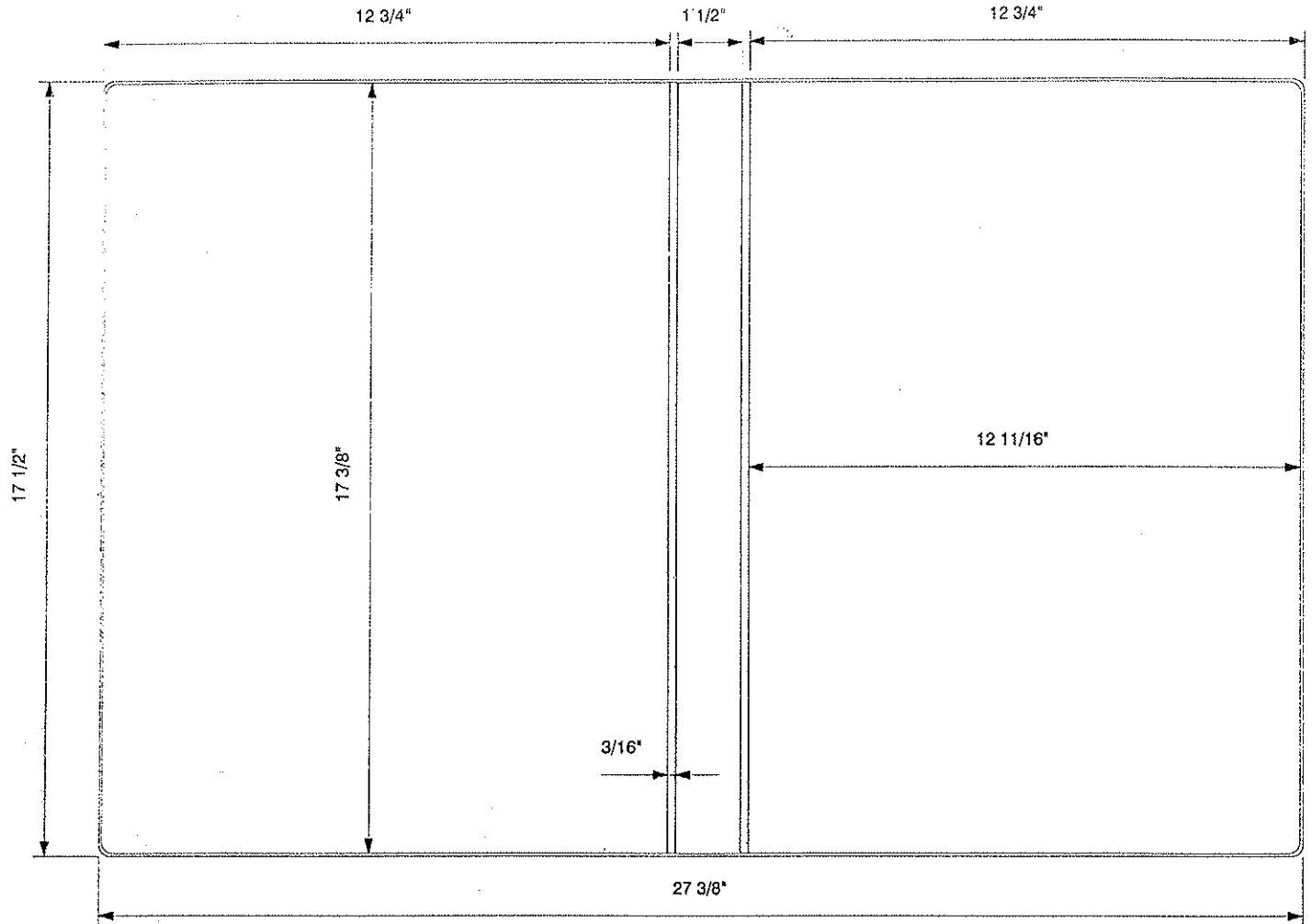

MATERIAL SPECS		GAUGE	PCS.	MATERIAL SPECS		GAUGE	PCS.				
COVER MAT.	18 1/4 X 28 1/8		1	LINING MAT.	18 1/4 X 28 1/8		1				
COVER MAT.				LINING MAT.							
DIE CUT				HORZ. PKT.							
COL	17 11/16 X 28 1/8		1	VERT. PKT.							
LABEL HOLDER				DIE CUT							
GUSSET				REINF.	17 1/4 x 2 1/4	SKRIM	1				
BOARD SPECS		5/16" R. CORNERS		GAUGE	PCS.	BOARD SPECS		5/16" R. CORNERS		GAUGE	PCS.
F.C. BOARD	17 5/16 X 12 5/8	120	1	F.C. BOARD							
B.B. BOARD	17 5/16 X 1 13/32	120	1	B.B. BOARD							
B.C. BOARD	17 5/16 X 12 5/8	120	1	B.C. BOARD							
FLAP BD.				DIE CUT							
BOARD				DIE CUT							



DIE #	6704	METAL	HOC	RADIUS	1/8"
ORDER #	237665	CUSTOMER	CARRIER COPORATION	TEAR SEAL	.014
SHEET SIZE	11 X 9 1/2	STYLE CASE	VINYL PLATFORM EASEL	BAR SEAL	FLAT
CAP.	2"	DUE DATE	5-12-99	COMPLETED	
LOCATION	I-12-7 & 8	QUANTITY	1	DATE	5-7-99

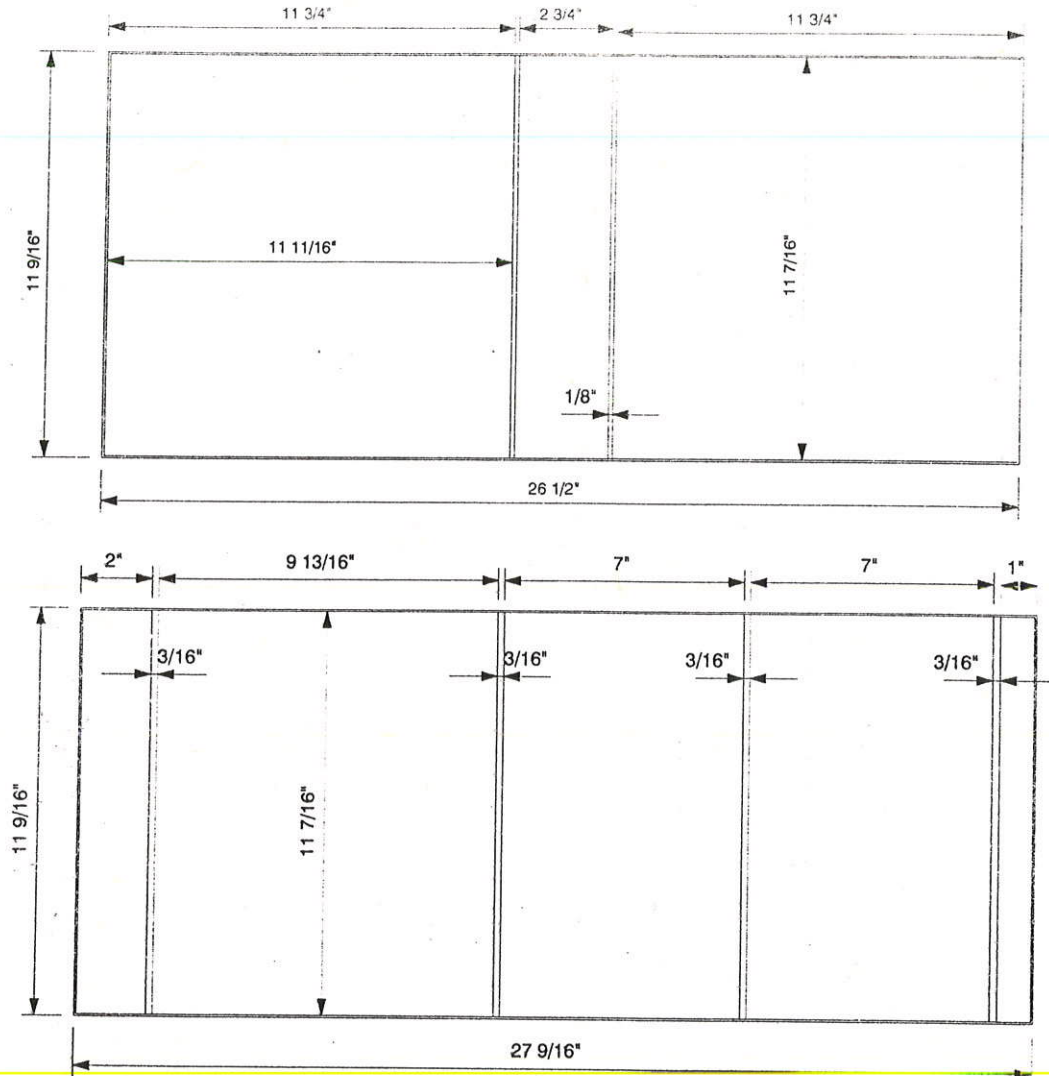

MATERIAL SPECS		GAUGE	PCS.	MATERIAL SPECS		GAUGE	PCS.
COVER MAT.	12 5/16 X 27 1/4	Binder	1	LINING MAT.	12 5/16 X 27 1/4	Binder	1
COVER MAT.	12 5/16 X 28 3/8	Foot	1	LINING MAT.	12 5/16 X 28 3/8	Foot	1
DIE CUT				HORZ. PKT.	4 7/8 x 27 1/4		
COL	11 11/16 X 15 1/4		1	VERT. PKT.			
LABEL HOLDER				DIE CUT			
GUSSET				REINF.			
BOARD SPECS		GAUGE	PCS.	BOARD SPECS		GAUGE	PCS.
F.C. BOARD	11 3/8 X 11 5/8	120	1	F.C. BOARD	11 3/8 X 6 29/32	120	2
B.B. BOARD	11 3/8 X 2 21/32	120	1	B.B. BOARD	11 3/8 X 29/32	120	1
B.C. BOARD	11 3/8 X 11 5/8	120	1	B.C. BOARD	11 3/8 X 1 29/32	120	1
FLAP BD.				DIE CUT			
BOARD	11 3/8 X 9 3/4	120	1	DIE CUT			

DIE #	6802	METAL	LOC 6.5	RADIUS	3/8"
ORDER #	292921	CUSTOMER	HORN STRONACH BLOOM	TEAR SEAL	.012
SHEET SIZE	6.5 X 6	STYLE CASE	VINYL PLATFORM EASEL	BAR SEAL	253-178
CAP.	1"	DUE DATE	12-10-99	COMPLETED	
LOCATION		QUANTITY	5000	DATE	11-22-99

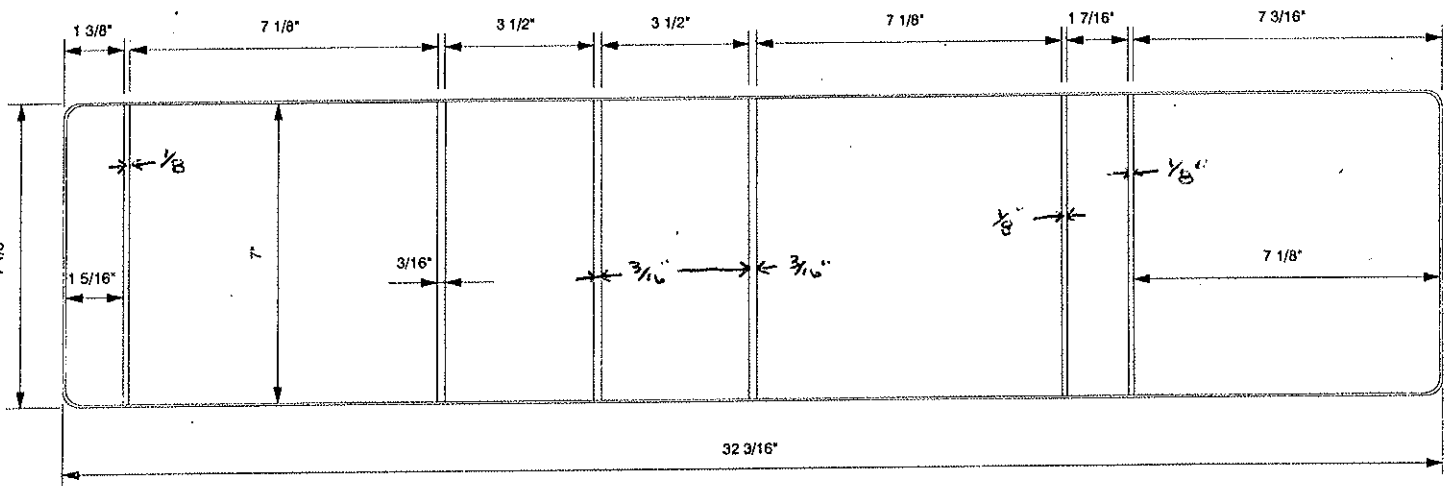

MATERIAL SPECS		GAUGE	PCS.	MATERIAL SPECS		GAUGE	PCS.
COVER MAT.	7 7/8 X 33		1	LINING MAT.	7 7/8 X 33		1
COVER MAT.				LINING MAT.			
DIE CUT				HORZ. PKT.			
COL				VERT. PKT.			
LABEL HOLDER				DIE CUT			
GUSSET				REINF.			

BOARD SPECS	5/16" B. CORNERS	GAUGE	PCS.	BOARD SPECS	5/16" B. CORNERS	GAUGE	PCS.
F.C. BOARD	6 15/16 X 7 1/16	100	1	F.C. BOARD	6 15/16 X 3 13/32	100	2
B.B. BOARD	6 15/16 X 1 11/32	100	1	B.B. BOARD			
B.C. BOARD	6 15/16 X 7 1/16	100	1	B.C. BOARD			
FLAP BD.				DIE CUT			
BOARD	6 15/16 X 7 1/16	100	1	DIE CUT			

DIE #	6846	METAL	HOC	RADIUS	
ORDER #	308291	CUSTOMER	PUBLIX PRINT SHOP	TEAR SEAL	.014
SHEET SIZE	8 1/2 X 11 1/2	STYLE CASE	VINYL PLATFORM EASEL	BAR SEAL	253-178
CAP.	2"	DUE DATE	2-11-00	COMPLETED	
LOCATION		QUANTITY	750	DATE	1-25-00

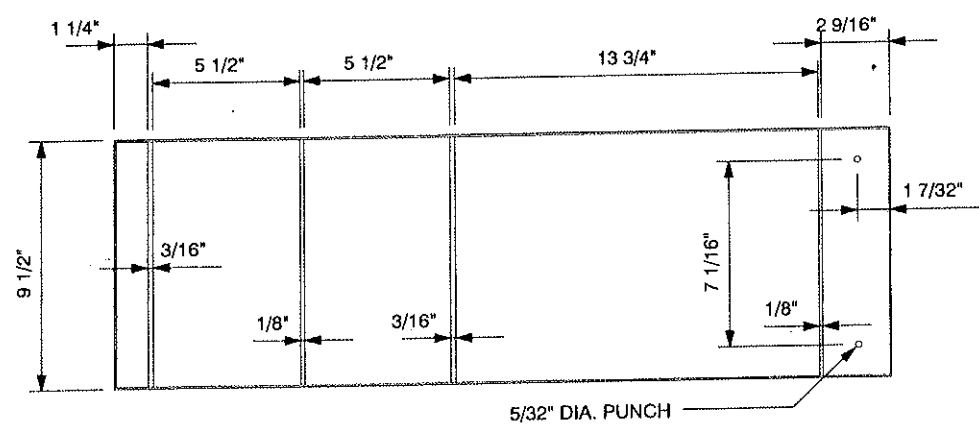
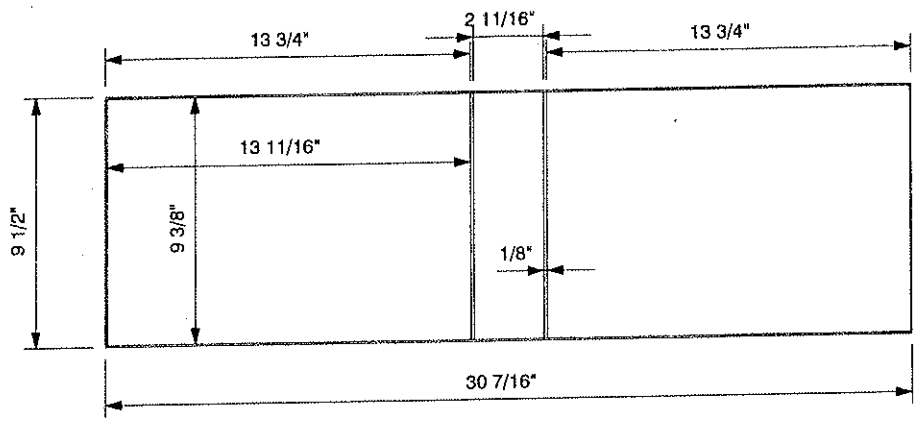

MATERIAL SPECS		QTY	PCS.	MATERIAL SPECS		GAUGE	PCS.
COVER MAT.	10 1/4 X 31 1/4	1		LINING MAT.	10 1/4 X 31 1/4		1
COVER MAT.	10 X 30	1		LINING MAT.	10 X 30		1
DIE CUT				HORZ. PKT.			
COL	9 5/8 X 17 1/2	1		VERT. PKT.			
LABEL HOLDER				DIE CUT			
GUSSET				REINF.			

BOARD SPECS		GAUGE	PCS.	BOARD SPECS		GAUGE	PCS.
F.C. BOARD	9 5/16 X 13 5/8		1	F.C. BOARD	9 5/16 X 13 11/16		1
B.B. BOARD	9 5/16 X 2 19/32		1	B.B. BOARD	9 5/16 X 5 13/32		2
B.C. BOARD	9 5/16 X 13 5/8		1	B.C. BOARD			
FLAP BD.	9 5/16 X 1 3/32		1	DIE CUT			
BOARD -				DIE CUT			

DIE #	6853 A-B	METAL	RR N/B	RADIUS	
ORDER #	309008	CUSTOMER	BEACON PRESS <i>Platform</i>	TEAR SEAL	.012
SHEET SIZE	14.625 X 12	STYLE CASE	<del>VINYL RING BINDER</del> <i>Kesel</i>	BAR SEAL	253-178
CAP.	1 1/4"	DUE DATE	2-4-00	COMPLETED	
LOCATION		QUANTITY	3	DATE	1-28-00

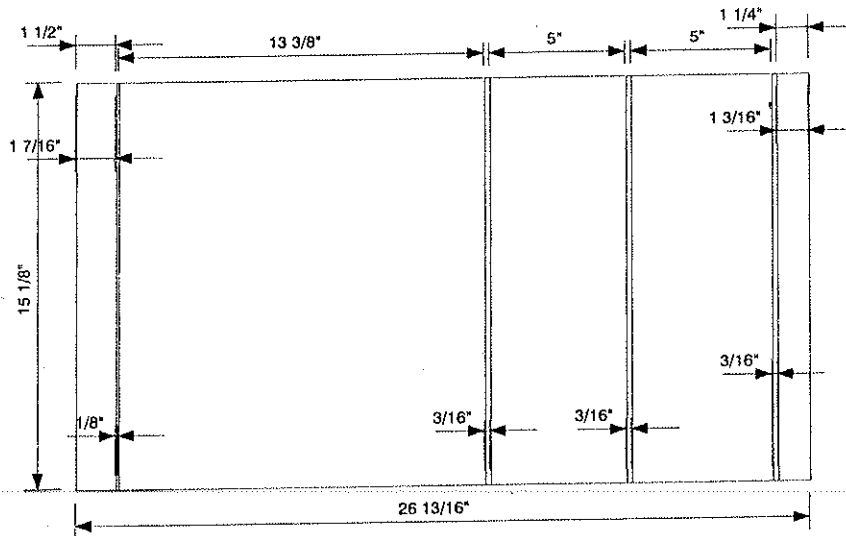
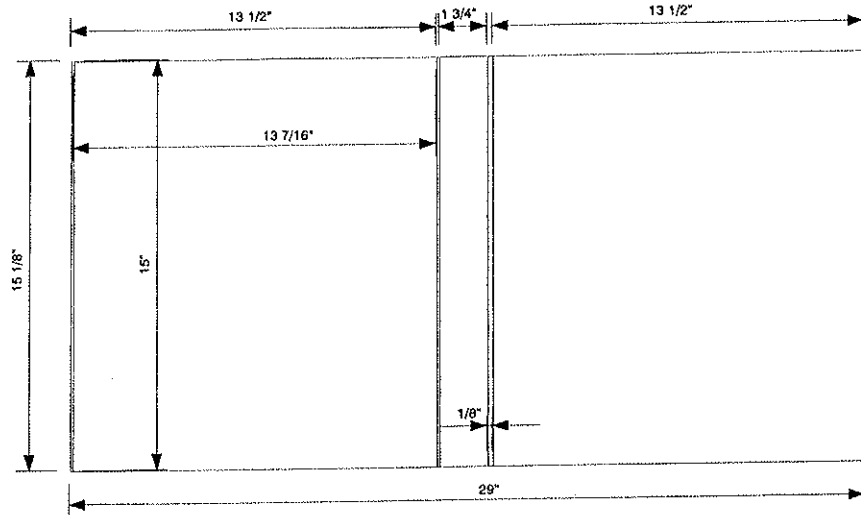

MATERIAL SPECS		GAUGE	PCS.	MATERIAL SPECS		GAUGE	PCS.
COVER MAT.	15 7/8 x 29 3/4		1	LINING MAT.	15 7/8 x 29 3/4		1
COVER MAT.	15 7/8 x 27 1/2		1	LINING MAT.	15 7/8 x 27 1/2		1
DIE CUT				HORZ. PKT.			
COL	15 1/4 x 16 1/2		1	VERT. PKT.			
LABEL HOLDER				DIE CUT			
GUSSET				REINF.			

BOARD SPECS		5/16" R. CORNERS		GAUGE	PCS.	BOARD SPECS		5/16" R. CORNERS		GAUGE	PCS.
F.C. BOARD	14 15/16 x 13 3/8	120	1	F.C. BOARD	14 15/16 x 13 7/16	120	1				
B.B. BOARD	14 15/16 x 1 21/32	120	1	B.B. BOARD	14 15/16 x 1 3/32	120	1				
B.C. BOARD	14 15/16 x 13 3/8	120	1	B.C. BOARD							
FLAP BD.				DIE CUT							
BOARD -				DIE CUT							

DIE #	6885	METAL	RR NO BOOSTER	RADIUS	1/4"
ORDER #	321525	CUSTOMER	PUBLIX	TEAR SEAL	.014
SHEET SIZE	17 X 11.75	STYLE CASE	VINTL EASEL	BAR SEAL	178 FLAT
CAP.	1.5"	DUE DATE	4-11-00	COMPLETED	
LOCATION		QUANTITY	700	DATE	3-22-00

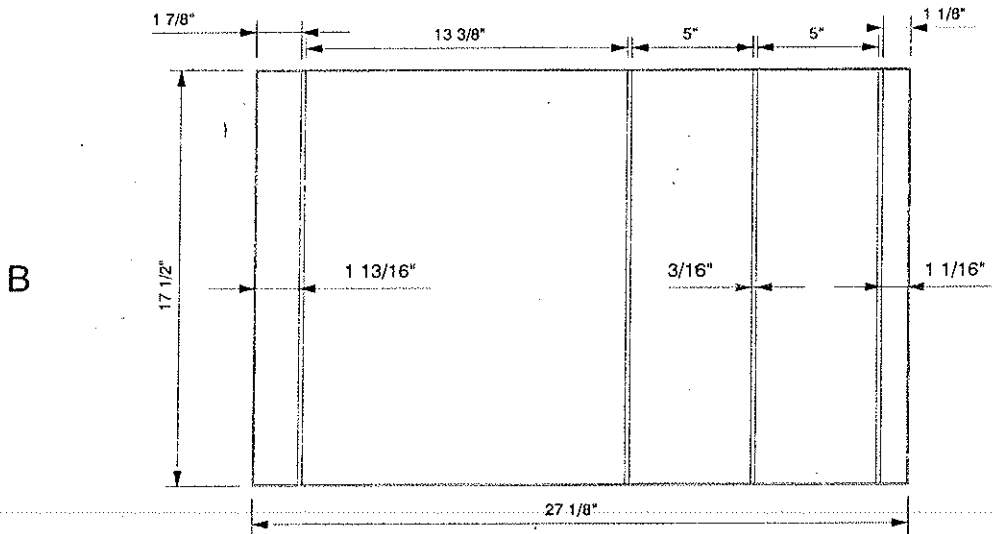
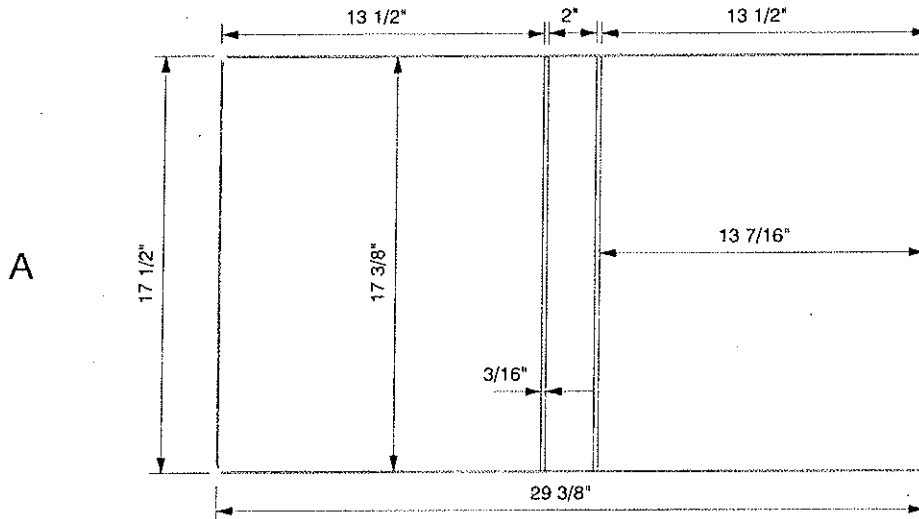

MATERIAL SPECS		GAUGE	PCS.	MATERIAL SPECS		GAUGE	PCS.
COVER MAT.	18 1/2 X 30 3/8	A	1	LINING MAT.	18 1/2 X 30 3/8	A	1
COVER MAT.	18 1/2 X 28 1/8	B	1	LINING MAT.	18 1/2 X 28 1/8	B	1
DIE CUT				HORZ. PKT.			
COL	17 5/8 X 16 3/4	A	1	VERT. PKT.			
LABEL HOLDER				DIE CUT			
GUSSET				REINF.			

BOARD SPECS		A		GAUGE	PCS.	BOARD SPECS		B		GAUGE	PCS.
F.C. BOARD	17 5/16 X 13 3/8	120	1	F.C. BOARD	17 5/16 X 13 5/16	120	1				
B.B. BOARD	17 5/16 X 1 29/32	120	1	B.B. BOARD	17 5/16 X 4 29/32	120	2				
B.C. BOARD	17 5/16 X 13 3/8	120	1	B.C. BOARD	17 5/16 X 15/16	120	1				
FLAP BD.				DIE CUT							
BOARD				DIE CUT							

DIE #	6991	METAL	KEY RING METAL	RADIUS	1/8"
ORDER #		CUSTOMER	VIP (MARKETING DEPT)	TEAR SEAL	.008
SHEET SIZE	2 5/8 X 2 1/8	STYLE CASE	MINI PLATFORM EASEL	BAR SEAL	102-253
CAP.	3/8"	DUE DATE		COMPLETED	
LOCATION		QUANTITY	3000	DATE	10-5-00

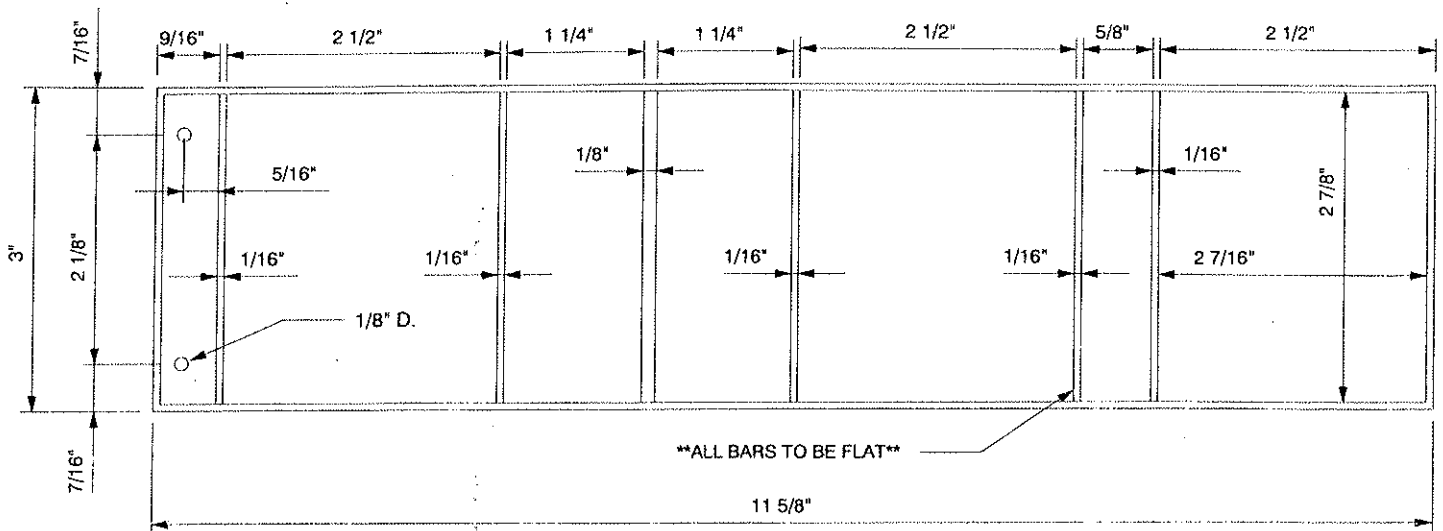

SCREEN / STAMP 3 UP THEN  
TRIM DOWN TO 3 3/4 X 12 3/8

MATERIAL SPECS		GAUGE	PCS.	MATERIAL SPECS		GAUGE	PCS.
COVER MAT.	11 1/4 X 12 3/8	30OUT	1	LINING MAT.	3 3/4 X 12 3/8	30OUT	1
COVER MAT.				LINING MAT.			
DIE CUT				HORZ. PKT.			
COL				VERT. PKT.			
LABEL HOLDER				DIE CUT			
GUSSET				REINF.			

BOARD SPECS		5/16" R. CORNERS		GAUGE	PCS.	BOARD SPECS		5/16" R. CORNERS		GAUGE	PCS.
F.C. BOARD	2 25/32 X 2 11/32	80	1	F.C. BOARD							
B.B. BOARD	2 25/32 X 17/32	80	1	B.B. BOARD							
B.C. BOARD	2 25/32 X 2 13/32	80	1	B.C. BOARD							
FLAP BD.				DIE CUT							
BOARD	2 25/32 X 2 13/32	80	1	DIE CUT							

Product Code

Style Case **PLATFORM EASLE-2**

Sheet Size **8 1/2 x 11 1/2** Cap. **1 1/2**

Die No. **5131C<sup>AB</sup>**

Order No. **63237 & 8**

Plate **0-9-9**  
**0-10-1**

V-1

**EBSCO MEDIA ADVERTISING**

Customer

Metal
Total Vinyl
Quantity <b>150 + 150</b>
Date <b>7-25-92</b>
Type Corners
Radius <b>3/8 &amp; 0</b>
Completed

	Gauge	Thick
Tear Seal	.014	1/16
Bar Seal	48-4	5/16
Bar Seal		

	No. of Feet
Tear Seal	
Bar Seal	
Bar Seal	

*DWCY B-Pace*

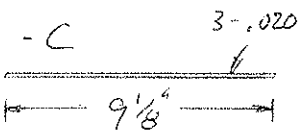
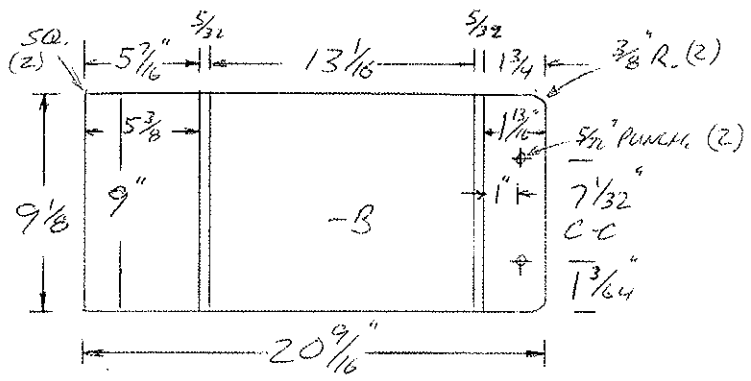
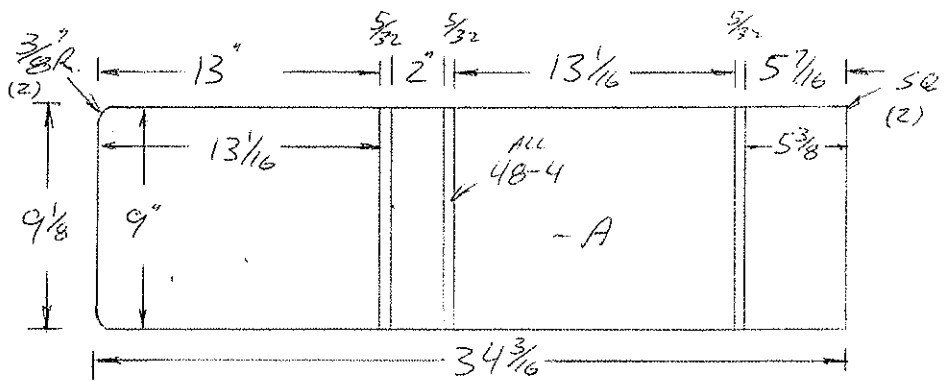

\*NOTE 1 PC. VERSION = 54" L.

Code	Ga.	PCS	Size	Cutting Specs		Code	Ga.	Pcs.	Size	Cutting Specs	
				#	Out					#	Out
Cover Mat. A	9 3/4	1	35"	14		Lining Mat. A	9 3/4	1	35"	14	
Cover Mat. B	9 3/4	1	21 3/8	14		Lining Mat. B	9 3/4	1	21 3/8	14	
Vert. Pckt.			X			Horz. Pckt.			X		
Vert. Rckt.			X			Horz. Pckt.			X		
Pocket			X			Pocket			X		
Label Holder			X			Card Holder			X		
Material			X			Material			X		
Material			X			Material			X		
Material			X			Material			X		
F.C. Board A	8 5/16	1	13"	100		B.C. Board			X		
B.C. Board A	8 5/16	1	13"	100		B.B. Board	8 5/16	1	29 3/32	100	
Center Board B	8 5/16	1	13"	100		Board			X		
Board			X			Strip			X		
Cover Pad			X			Strip			X		
						B.B. Pad			X		

DIE #	6995	METAL	8 1/2" LOC	RADIUS	
ORDER #	379815	CUSTOMER	THE SPELLMAN GROUP	TEAR SEAL	.012
SHEET SIZE	8.5 X 7	STYLE CASE	VINYL PLATFORM EASEL	BAR SEAL	253-178
CAP.	1"	DUE DATE	10-31-00	COMPLETED	
LOCATION		QUANTITY	1000	DATE	10-11-00

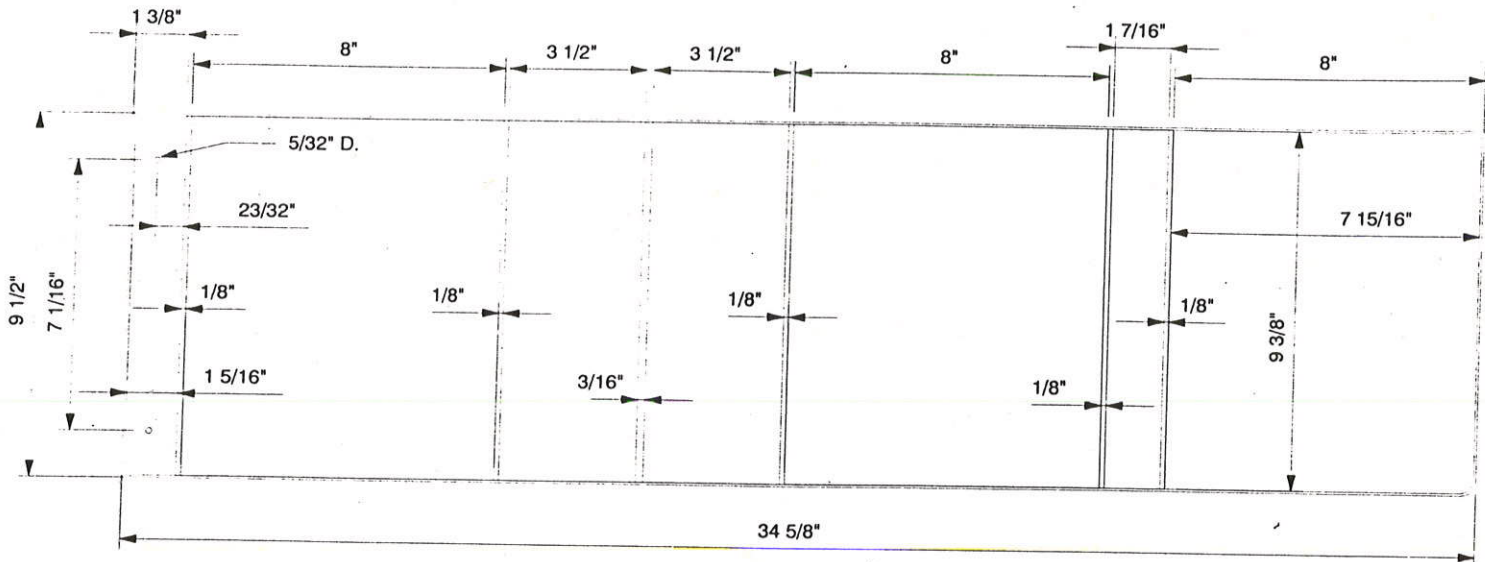

MATERIAL SPECS		GAUGE	PCS.	MATERIAL SPECS		GAUGE	PCS.
COVER MAT.	10 1/4 X 35 3/8		1	LINING MAT.	10 1/4 X 35 3/8		1
COVER MAT.				LINING MAT.			
DIE CUT				HORZ. PKT.			
COL	9 5/8 X 10 1/8		1	VERT. PKT.			
LABEL HOLDER				DIE CUT			
GUSSET				REINF.			
BOARD SPECS		5/16" R. CORNERS		BOARD SPECS		5/16" R. CORNERS	
F.C. BOARD	9 5/16 X 7 7/8	100	1	F.C. BOARD			
B.B. BOARD	9 5/16 X 1 11/32	100	1	B.B. BOARD			
B.C. BOARD	9 5/16 X 7 15/16	100	2	B.C. BOARD			
FLAP BD.				DIE CUT			
BOARD	9 5/16 X 3 3/8	100	2	DIE CUT			



DIE #	7046-A	METAL	2 RR N/B	RADIUS	
ORDER #	398371	CUSTOMER	WILSONART	TEAR SEAL	.010
SHEET SIZE	17 X 11.5	STYLE CASE	VINYL EASEL	BAR SEAL	253
CAP.	2"	DUE DATE	1-24-01	COMPLETED	
LOCATION		QUANTITY	350	DATE	1-11-01

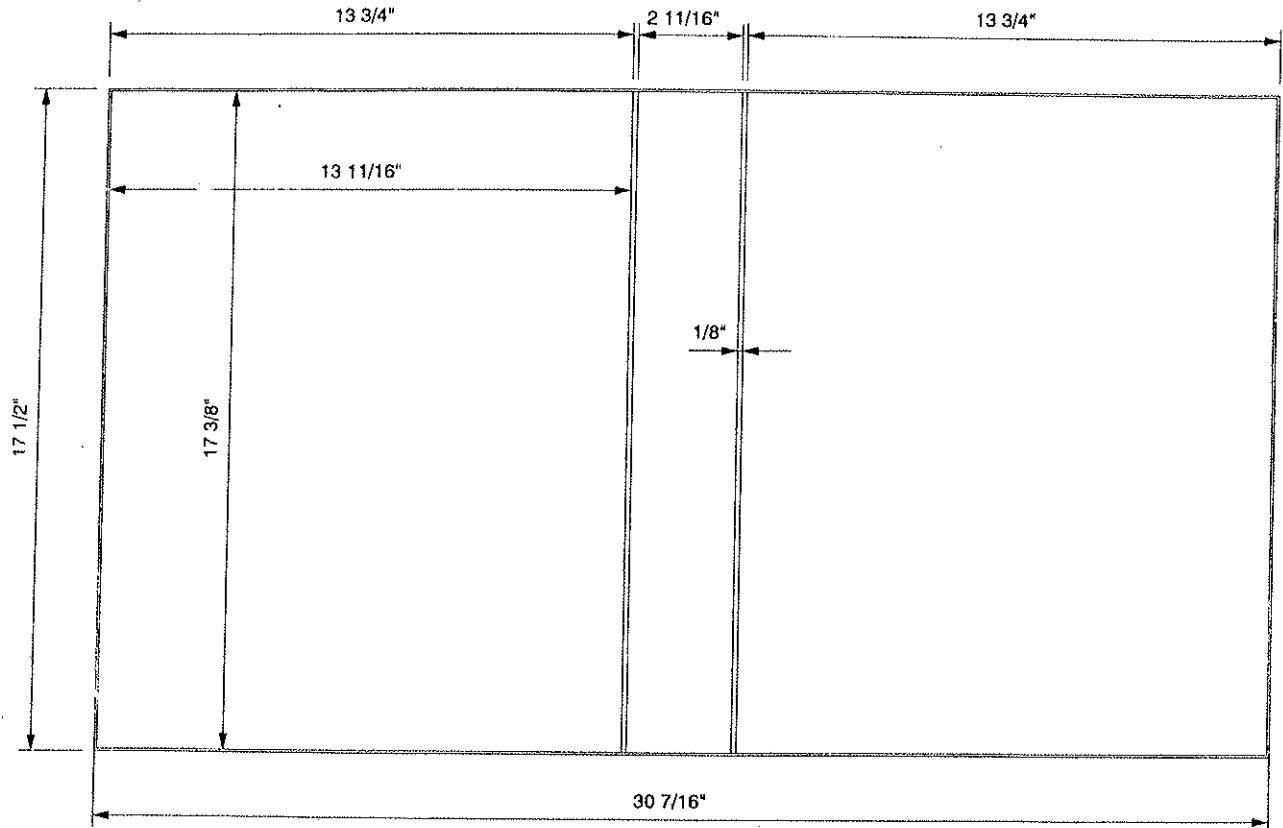

MATERIAL SPECS		GAUGE	PCS.	MATERIAL SPECS		GAUGE	PCS.
COVER MAT.	18 1/2 X 31 1/2		1	LINING MAT.	18 1/4 X 31 1/4		1
COVER MAT.				LINING MAT.			
DIE CUT				HORZ. PKT.			
COL				VERT. PKT.	18 1/4 x 5 3/8		1
LABEL HOLDER				DIE CUT			
GUSSET				REINF.			

BOARD SPECS		5/16" R. CORNERS		GAUGE	PCS.	BOARD SPECS		5/16" R. CORNERS		GAUGE	PCS.
F.C. BOARD	FC DIECUT (7046-C)					F.C. BOARD					
B.B. BOARD	17 5/16 X 2 19/32	120	1			B.B. BOARD					
B.C. BOARD	17 5/16 X 13 5/8	120	1			B.C. BOARD					
FLAP BD.						DIE CUT					
BOARD						DIE CUT					

DIE #	7245-A	METAL	2 - 8.5 RR METALS	RADIUS	3/8"
ORDER #	490661	CUSTOMER	VISUAL HORIZONS	TEAR SEAL	.012
SHEET SIZE	24 X 18 OA	STYLE CASE	VINYL EASEL	BAR SEAL	48-3
CAP.	1"	DUE DATE	5-3-02	COMPLETED	
LOCATION		QUANTITY	100	DATE	4-18-02

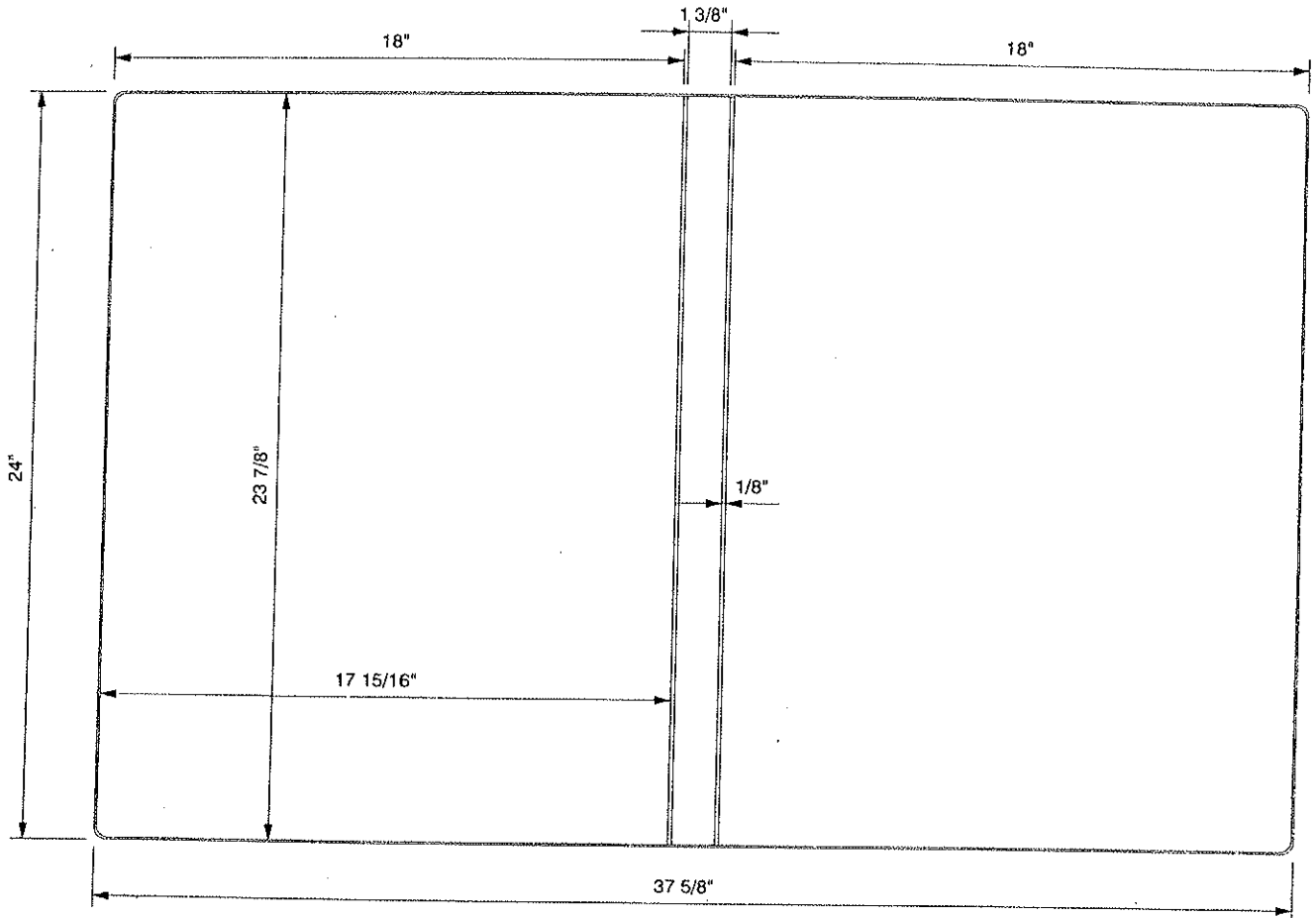

MATERIAL SPECS		GAUGE	PCS.	MATERIAL SPECS		GAUGE	PCS.
COVER MAT.	25 X 38 5/8		1	LINING MAT.	24 3/4 X 38 3/8		1
COVER MAT.				LINING MAT.			
DIE CUT				HORZ. PKT.			
COL				VERT. PKT.			
LABEL HOLDER				DIE CUT			
GUSSET				REINF.			
BOARD SPECS		GAUGE	PCS.	BOARD SPECS		GAUGE	PCS.
	5/16" R. CORNERS				5/16" R. CORNERS		
F.C. BOARD	23 25/32 X 17 27/32	135	1	F.C. BOARD			
B.B. BOARD	23 25/32 X 1 9/32	135	1	B.B. BOARD			
B.C. BOARD	23 25/32 X 17 27/32	135	1	B.C. BOARD			
FLAP BD.				DIE CUT			
BOARD				DIE CUT			



DIE #	7292	METAL	2 RING RR N/B KOLOMAN	RADIUS	3/8"
ORDER #	508816	CUSTOMER	GBS CORPORATION	TEAR SEAL	.010
SHEET SIZE	5 3/8 X 4	STYLE CASE	VINYL PLATFORM EASEL	BAR SEAL	FLAT
CAP.	1"	DUE DATE	8-7-02	COMPLETED	
LOCATION		QUANTITY	6	DATE	8-5-02

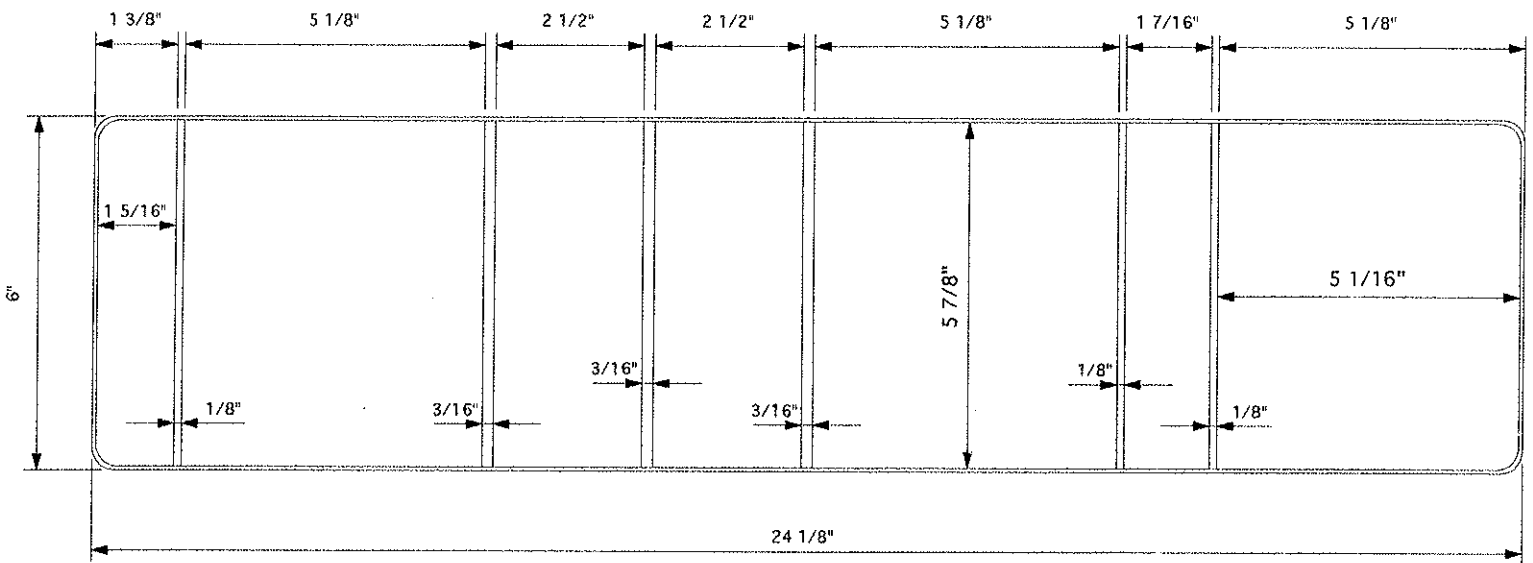

MATERIAL SPECS		GAUGE	PCS.	MATERIAL SPECS		GAUGE	PCS.
COVER MAT.	6 3/4 X 24 7/8		1	LINING MAT.	6 3/4 X 24 7/8		1
COVER MAT.				LINING MAT.			
DIE CUT				HORZ. PKT.			
COL				VERT. PKT.			
LABEL HOLDER				DIE CUT			
GUSSET				REINF.			
BOARD SPECS		5/16" R. CORNERS		BOARD SPECS		5/16" R. CORNERS	
F.C. BOARD	5 13/16 X 5	95	1	F.C. BOARD			
B.B. BOARD	5 13/16 X 1 11/32	95	1	B.B. BOARD			
B.C. BOARD	5 13/16 X 5 1/16	95	2	B.C. BOARD			
FLAP BD.				DIE CUT			
BOARD				DIE CUT			



DIE #	7665	METAL	2 - 11" LOC METALS	RADIUS	
ORDER #	614846	CUSTOMER	BOSTON BEER CO.	DATE	4-5-04
SHEET SIZE	22 X 24 1/2	STYLE CASE	CM EASEL	SPACE	
CAP.	1"	QUANTITY	1	DUE DATE	4-8-04

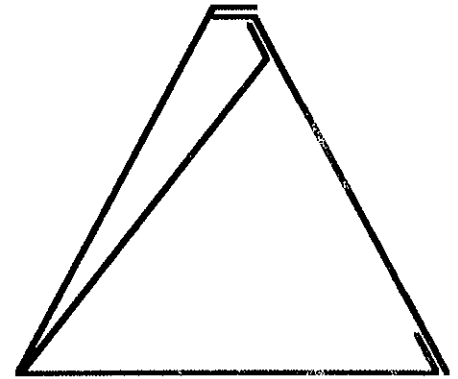
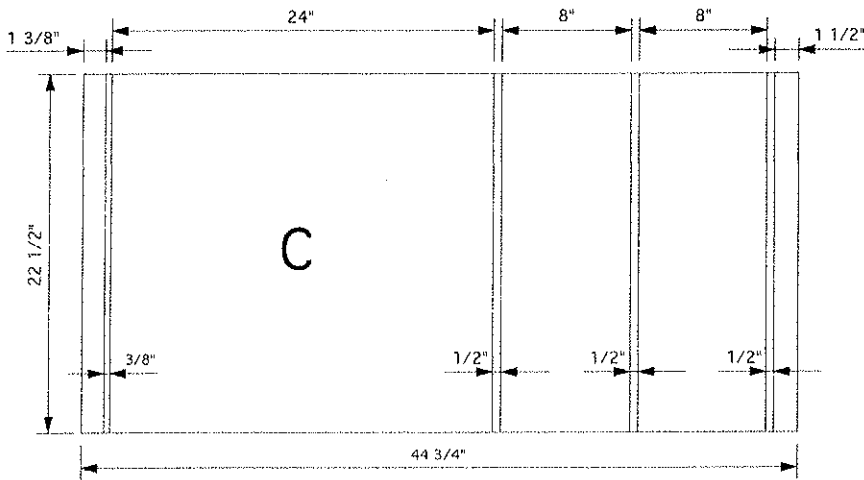
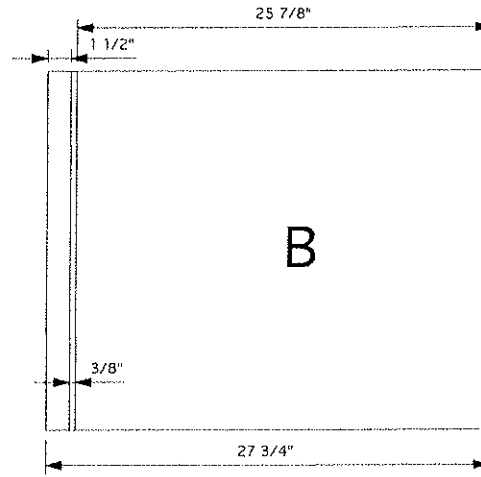
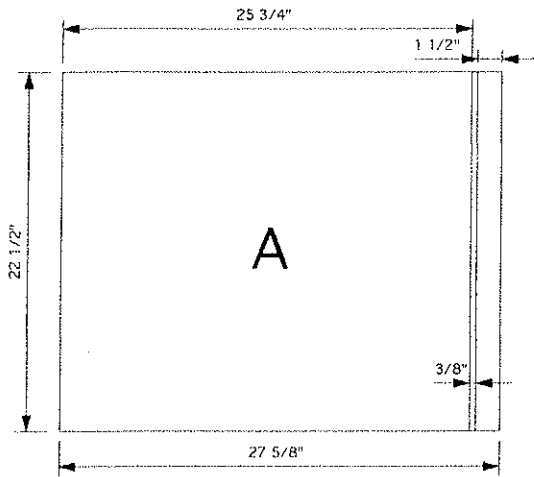

MATERIAL SPECS		GAUGE		MATERIAL SPECS		GAUGE	
COVER MAT.	24 X 29 1/8	A	1	LINING MAT.	22 1/4 X 25 1/2	A	1
COVER MAT.	24 X 29 1/4	B	1	LINING MAT.	22 1/4 X 25 5/8	B	1
COVER MAT.	24 X 46 1/4	C	1	LINING MAT.	22 1/4 X 23 3/4	C	1
REINF. MAT				REINF. MAT			
REINF. MAT				REINF. MAT	22 1/4 X 2 5/8	CANVAS	3
REINF. MAT				REINF. MAT	22 1/4 X 19 1/2	CANVAS	1

BOARD SPECS		GAUGE		BOARD SPECS		GAUGE	
BOARD	22 1/2 X 25 3/4	A	135	BOARD	22 1/2 X 1 1/2	A	135
BOARD	22 1/2 X 25 7/8	B	135	BOARD	22 1/2 X 1 1/2	B-C	135
BOARD	22 1/2 X 24	C	135	BOARD	22 1/2 X 1 3/8	C	135
BOARD				BOARD	22 1/2 X 8	C	100
BOARD				BOARD			

DIE #	7819-A-B	METAL	RR NB	RADIUS	1/4"
ORDER #	657918	CUSTOMER	PUBLIX SUPERMARKET	TEAR SEAL	.014
SHEET SIZE	9 X 11	STYLE CASE	VINYL PLATFORM EASEL	BAR SEAL	EVERLAST
CAP.	2 1/2"	DUE DATE	1-25-05	COMPLETED	
LOCATION		QUANTITY	950	DATE	1-17-05

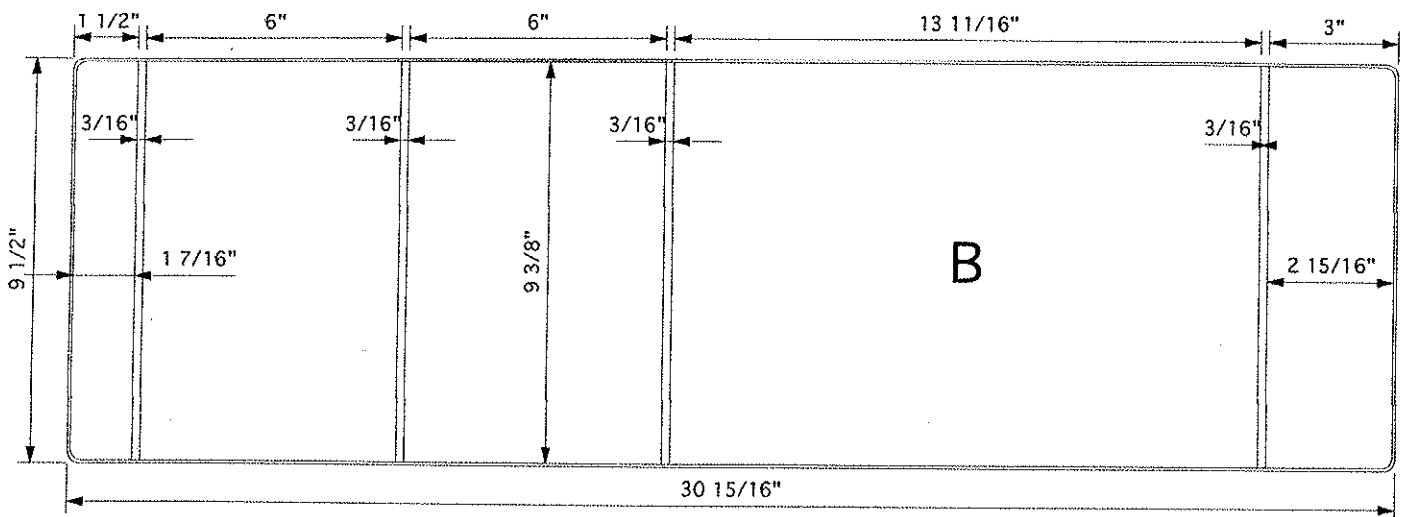
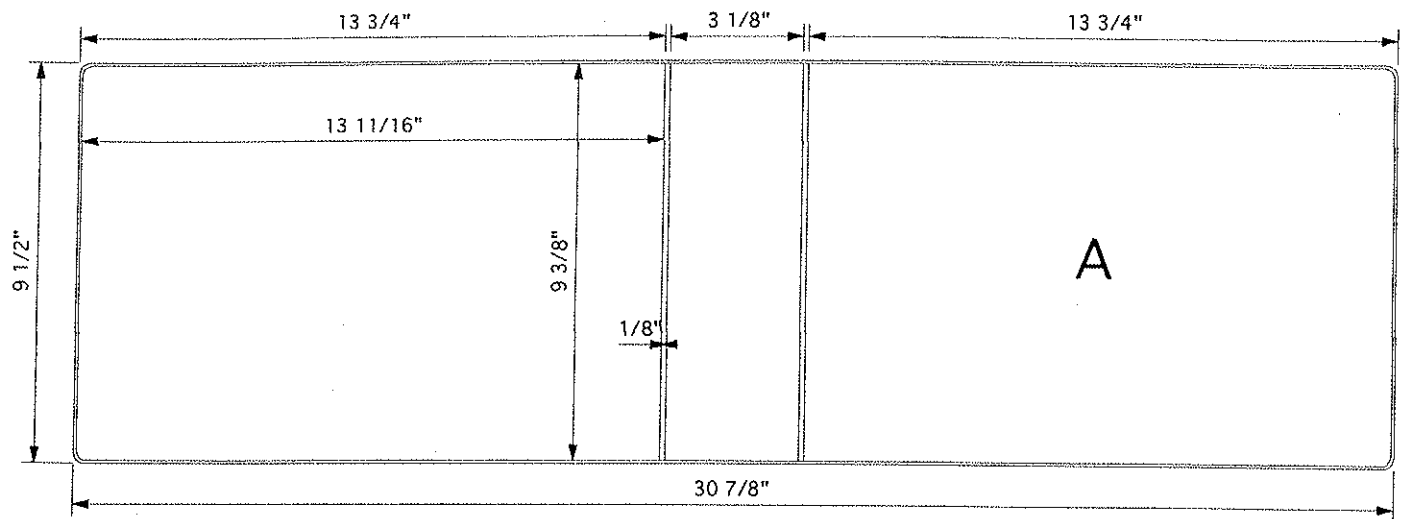

MATERIAL SPECS				GAUGE	PCS.	MATERIAL SPECS				GAUGE	PCS.
COVER MAT.	10 1/4 X 31 5/8	A			1	LINING MAT.	10 1/4 X 31 5/8	A			1
COVER MAT.	10 1/4 X 31 3/4	B			1	LINING MAT.	10 1/4 X 31 3/4	B			1
DIE CUT						HORZ. PKT.					
COL	9 5/8 X 17 1/2	A			1	VERT. PKT.					
LABEL HOLDER						DIE CUT					
GUSSET						REINF.					
BOARD SPECS				GAUGE	PCS.	BOARD SPECS				GAUGE	PCS.
F.C. BOARD	9 5/16 X 13 5/8	A	115		1	F.C. BOARD	9 5/16 X 13 5/8	B	115		1
B.B. BOARD	9 5/16 X 3 1/32	A	115		1	B.B. BOARD	9 5/16 X 5 29/32	B	48		2
B.C. BOARD	9 5/16 X 13 5/8	A	115		1	B.C. BOARD	9 5/16 X 1 11/32	B	115		1
FLAP BD.						DIE CUT	9 5/16 X 2 27/32	B	48		1
BOARD	9 9/32 X 3	A	35		1	DIE CUT					

DIE #	7841	METAL	RR NB 5" (2 RING)	RADIUS	1/4"
ORDER #	665387	CUSTOMER	PRINTING METHODS	TEAR SEAL	.012
SHEET SIZE	3 3/4 X 7 3/4	STYLE CASE	VINYL PLATFORM EASEL	BAR SEAL	253 TYP.
CAP.	1"	DUE DATE	3-3-05	COMPLETED	
LOCATION		QUANTITY	3	DATE	3-1-05

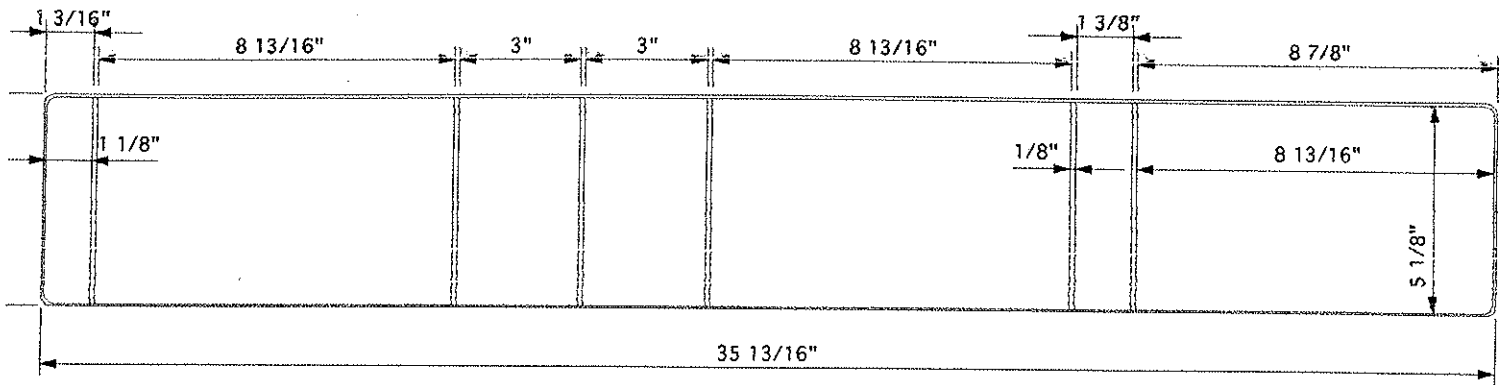

MATERIAL SPECS		GAUGE	PCS.	MATERIAL SPECS		GAUGE	PCS.
COVER MAT.	6 1/4 X 36 3/4		1	LINING MAT.	6 1/4 X 36 3/4		1
COVER MAT.				LINING MAT.			
DIE CUT				HORZ. PKT.			
COL				VERT. PKT.			
LABEL HOLDER				DIE CUT			
GUSSET				REINF.			
BOARD SPECS		GAUGE	PCS.	BOARD SPECS		GAUGE	PCS.
	5/16" R. CORNERS				5/16" R. CORNERS		
BOARD	5 1/32 X 8 23/32	120	3	F.C. BOARD			
B.B. BOARD	5 1/32 X 1 9/32	120	1	B.B. BOARD			
B.C. BOARD				B.C. BOARD			
FLAP BD.				DIE CUT			
BOARD				DIE CUT			



DIE #	7964	METAL	2 RING NB	RADIUS	3/8"
ORDER #	688351	CUSTOMER	QUALITY PRINTING	TEAR SEAL	.012
SHEET SIZE	5 1/2 X 9	STYLE CASE	VINYL PLATFORM EASEL W/FLAP	BAR SEAL	FLAT
CAP.	1"	DUE DATE	8-17-05	COMPLETED	
LOCATION		QUANTITY	250	DATE	8-15-05

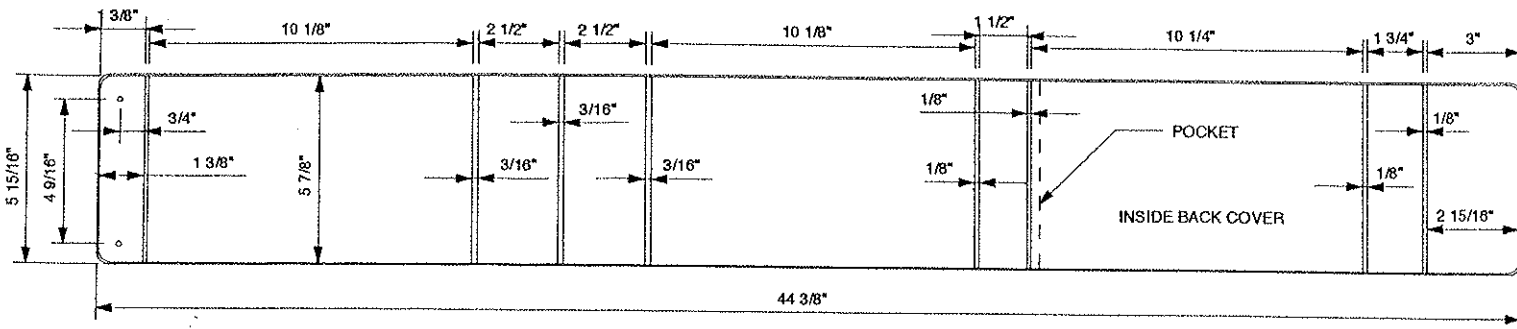

MATERIAL SPECS		GAUGE	PCS.	MATERIAL SPECS	GAUGE	PCS.
COVER MAT.	7 X 45 3/8		1	LINING MAT.	6 3/4 X 45 1/8	1
COVER MAT.				LINING MAT.		
DIE CUT				HORZ. PKT.		
COL				VERT. PKT.	6 3/4 X 10 1/8	1
LABEL HOLDER				DIE CUT		
GUSSET				REINF.		
BOARD SPECS		GAUGE	PCS.	BOARD SPECS	GAUGE	PCS.
F.C. BOARD	5 25/32 X 10 1/32	100	2	F.C. BOARD		
B.B. BOARD	5 25/32 X 1 13/32	100	1	B.B. BOARD		
B.C. BOARD	5 25/32 X 10 5/32	100	1	B.C. BOARD		
FLAP BD.	5 25/32 X 2 27/32	100	1	DIE CUT		
BOARD	5 25/32 X 1 21/32	100	1	DIE CUT		

DIE #	8450-A-B	METAL	RR	RADIUS	1/4"
ORDER #	825301	CUSTOMER	PUBLIX SUPERMARKET	TEAR SEAL	.014
SHEET SIZE	11 X 14 1/2	STYLE CASE	2 PC. VINYL PLATFORM EASEL	BAR SEAL	253
CAP.	1"	DUE DATE	2-4-08	COMPLETED	
LOCATION		QUANTITY	50	DATE	1-17-08

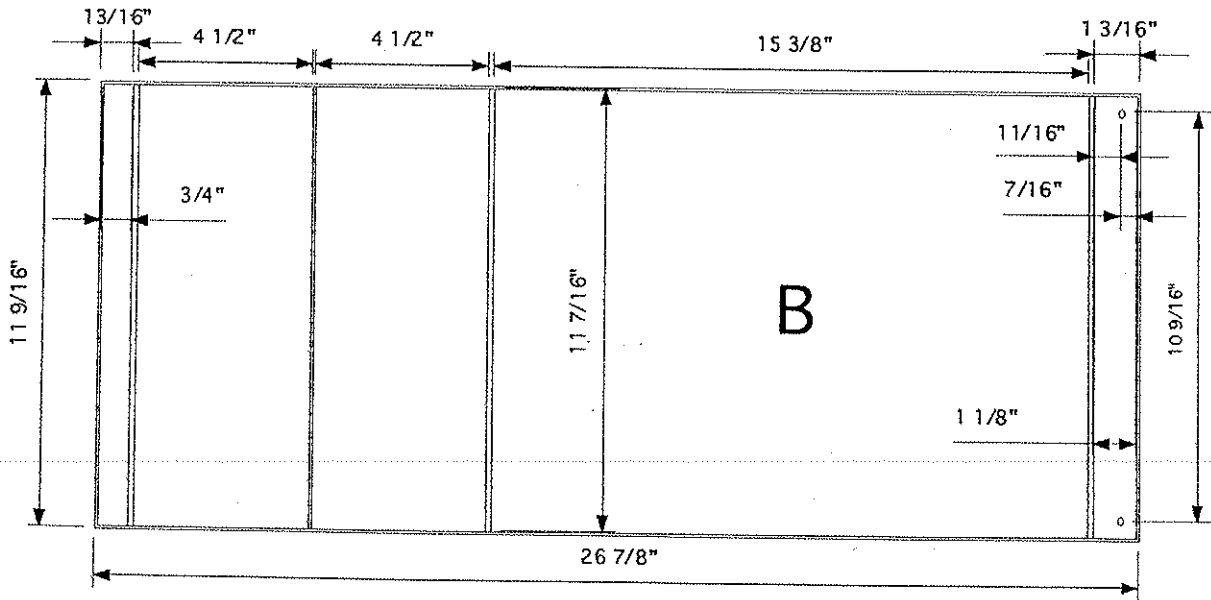
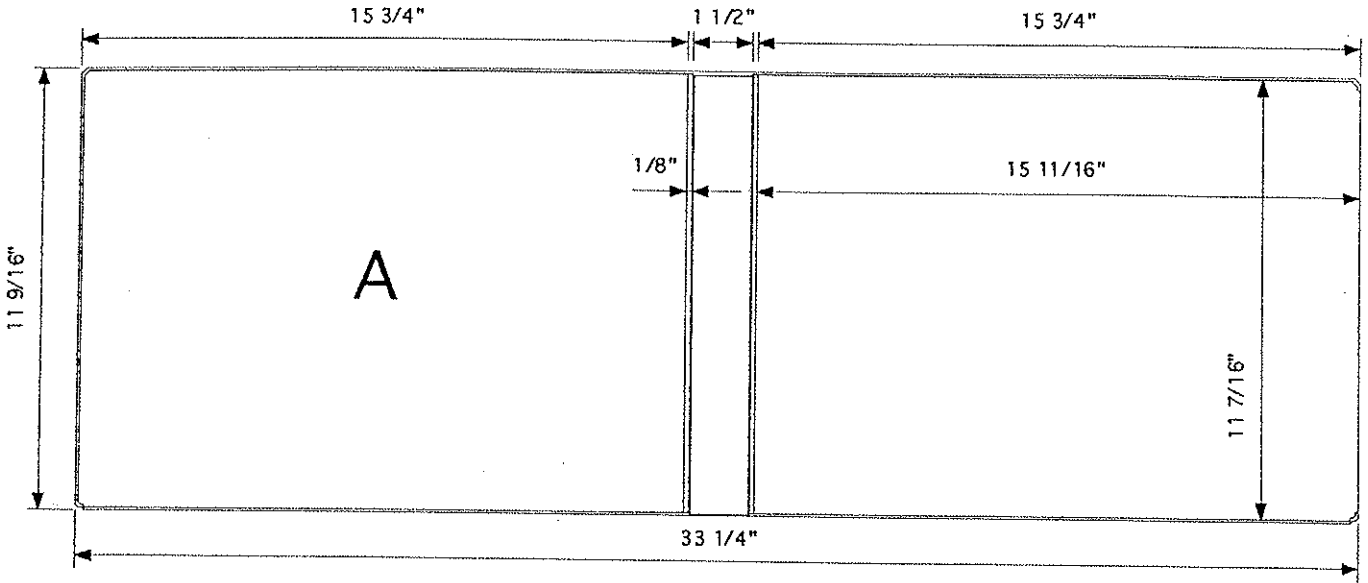

MATERIAL SPECS		GAUGE		PCS.		MATERIAL SPECS		GAUGE		PCS.	
COVER MAT.	12 5/16 X 34	A	1	LINING MAT.	12 5/16 X 34	A	1				
COVER MAT.	12 5/16 X 27 5/8	B	1	LINING MAT.	12 5/16 X 27 5/8	B	1				
COVER MAT.				LINING MAT.							
EX COL.	11 11/16 X 18 1/2	A	1	REINF.							

BOARD SPECS		GAUGE		PCS.		BOARD SPECS		GAUGE		PCS.	
F.C. BOARD	11 11/32 X 15 19/32	A	120	1	BOARD	11 11/32 X 15 9/32	120	1			
B.B. BOARD	11 11/32 X 1 13/32	A	120	1	BOARD	11 11/32 X 21/32	120	1			
B.C. BOARD	11 11/32 X 15 19/32	A	120	1	BOARD	11 11/32 X 4 13/32	35	2			
FLAP BD.					BOARD						
BOARD					BOARD						

DIE #	8686	METAL	RR NB	RADIUS	3/8"
ORDER #	890322	CUSTOMER	PRINTWORX OF LOUISVILLE	TEAR SEAL	.014
SHEET SIZE	10 + 1/2 X 7	STYLE CASE	PLATFORM EASEL W/FLAP	BAR SEAL	253
CAP.	1 1/2"	DUE DATE	4-20-09	COMPLETED	
LOCATION		QUANTITY	1	DATE	4-21-09

\*\*\* WARNING DRAWING NOT ACTUAL SIZE \*\*\*

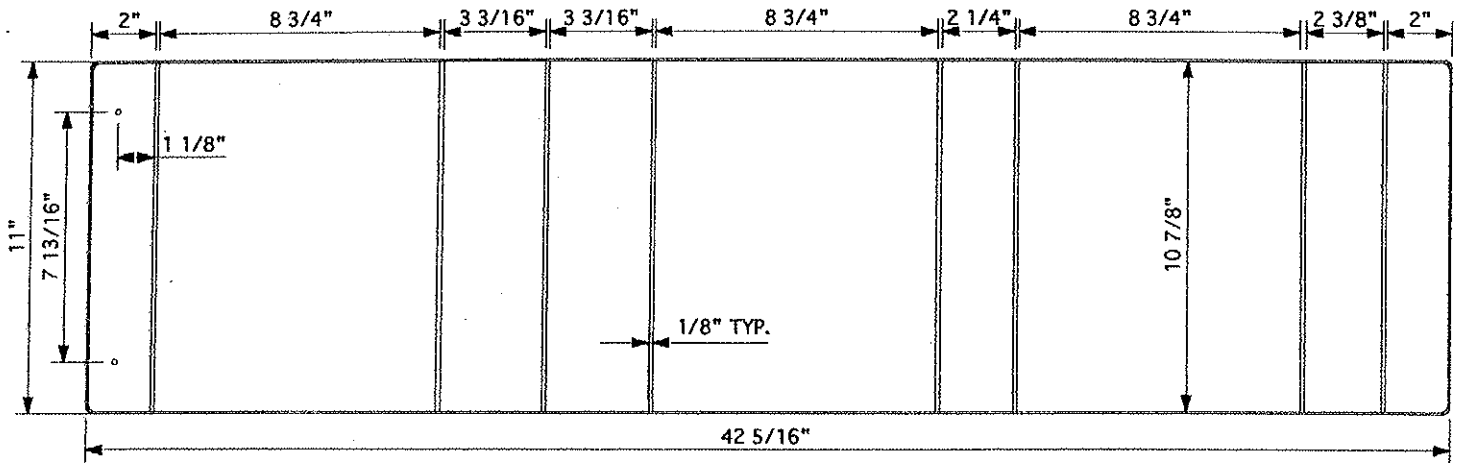

MATERIAL SPECS		GAUGE	PCS.	MATERIAL SPECS		GAUGE	PCS.
COVER MAT.	11 3/4 x 28 13/16		1	LINING MAT.	11 3/4 x 43 1/16		1
COVER MAT.	11 3/4 x 14 11/16		1	LINING MAT.			
DIE CUT				HORZ. PKT.			
COL				VERT. PKT.			
LABEL HOLDER				DIE CUT			
GUSSET				REINF.			
BOARD SPECS		GAUGE	PCS.	BOARD SPECS		GAUGE	PCS.
BOARD	10 13/16 x 8 11/16	98	3	F.C. BOARD			
BOARD	10 13/16 x 2 5/32	98	1	B.B. BOARD			
BOARD	10 13/16 x 2 9/32	98	1	B.C. BOARD			
FLAP BD.	10 13/16 x 1 27/32	98	1	DIE CUT			
BOARD				DIE CUT			

Product Code

Style Case *Easel w/cap Cassette*

Sheet Size  $8\frac{1}{2}$  X  $11\frac{1}{2}$  Cap. *7* Die No. *2452* Order No. *11156-7* Plate

Customer

*Lanier Business Products*

Metal
Total Vinyl <i>.030</i>
Quantity <i>1100</i>
Date <i>4-1-80</i>
Type Corners <i>RD</i>
Radius <i>1/4</i>
Completed

	Gauge	Thick
Tear Seal	<i>1016</i>	<i>3/32</i>
Bar Seal	<i>175</i>	<i>3/16</i>
Bar Seal		

	No. of Feet
Tear Seal	
Bar Seal	
Bar Seal	

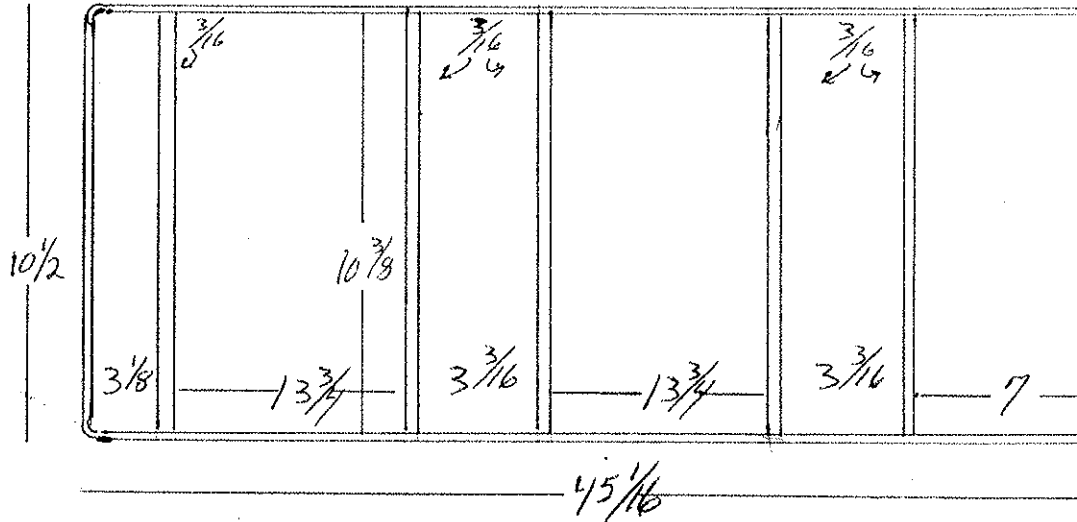

Code	Cutting Specs.				Code	Cutting Specs.			
	Ga.	# PCS	Size	Out		Ga.	# Pcs.	Size	Out
Cover Mat.			$11\frac{1}{8}$ X $45\frac{13}{16}$	1	Lining Mat.			$11\frac{1}{8}$ X $45\frac{13}{16}$	1
Cover Mat			X		Lining Mat.			X	
Vert. Pckt.			X		Horz. Pckt.			X	
Vert. Pckt.			X		Horz. Pckt.			X	
Pocket			X		Pocket			X	
Label Holder			X		Card Holder			X	
Material			X		Material			X	
Material			X		Material			X	
Material			X		Material			X	
F.C. Board			$10\frac{1}{4}$ X $13\frac{5}{8}$	2	B.C. Board			$10\frac{1}{4}$ X $6\frac{7}{8}$	1
B.C. Board			X		B.B. Board			$10\frac{1}{4}$ X $3\frac{1}{16}$	2
Center Board			X		Board			$10\frac{1}{4}$ X 3	1
Board			X		Strip			X	
Cover Pad			X		Strip			X	
					B.B. Pad			X	