

Product Code

Pyramid Style Case Footed Easel

Sheet Size

11 x 8 1/2

Cap. 3/4

Die No. 3929

Order No. 1000124

Plate

Customer

AAFES

Metal
Total Vinyl
Quantity 1
Date
Type Corners Rd
Radius 1/8
Completed

	Gauge	Thick
Tear Seal	16	3/32
Bar Seal	25J	1/2
Bar Seal	31k	

	No. of Feet
Tear Seal	
Bar Seal	
Bar Seal	

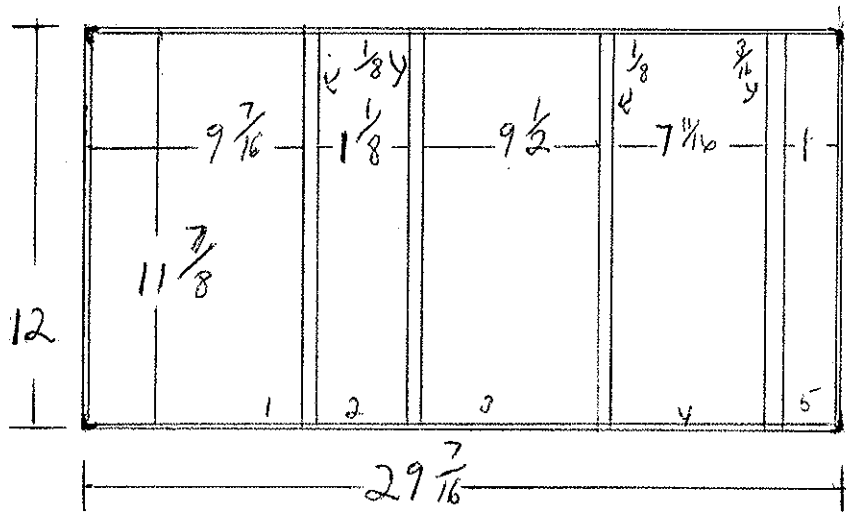

Code	Ga.	#	PCS	Cutting Specs.		Code	Ga.	#	PCS	Cutting Specs.	
				Size	Out					Size	Out
Cover Mat.				12 5/8 X	30 1/2	Lining Mat.				12 5/8 X	30 1/2
Cover Mat				X		Lining Mat.				X	
Vert. Pckt.				X		Horz. Pckt.				X	
Vert. Pckt.				12 5/8 X	9 7/8	Horz. Pckt.				X	
Pocket				X		Pocket				X	
Label Holder				3 5/8 X	2 3/8	Card Holder				X	
Material				X		Material				12 5/8 X	2 3/8
Material				X		Material				X	
Material				X		Material				X	
F.C. Board	1			11 25/32	9 1/32	B.C. Board				X	
B.C. Board	2			11 25/32	1 1/32	B.B. Board				X	
Center Board	3			11 25/32	9 13/32	Board				X	
Board	4			11 25/32	7 19/32	Strip				X	
Cover Pad	5			11 25/32	29 1/32	Strip				X	
						B.B. Pad				X	

Product Code

Style Case *Footed Pyramid Ensel*

Sheet Size 11 X 10 Cap. 1/2 Die No. 3743 Order No. 954396 Plate

Customer

U.S. Benefit Corp.

Metal
Total Vinyl <i>.030</i>
Quantity <i>30</i>
Date <i>2-25-87</i>
Type Corners <i>RJ</i>
Radius <i>1/4</i>
Completed

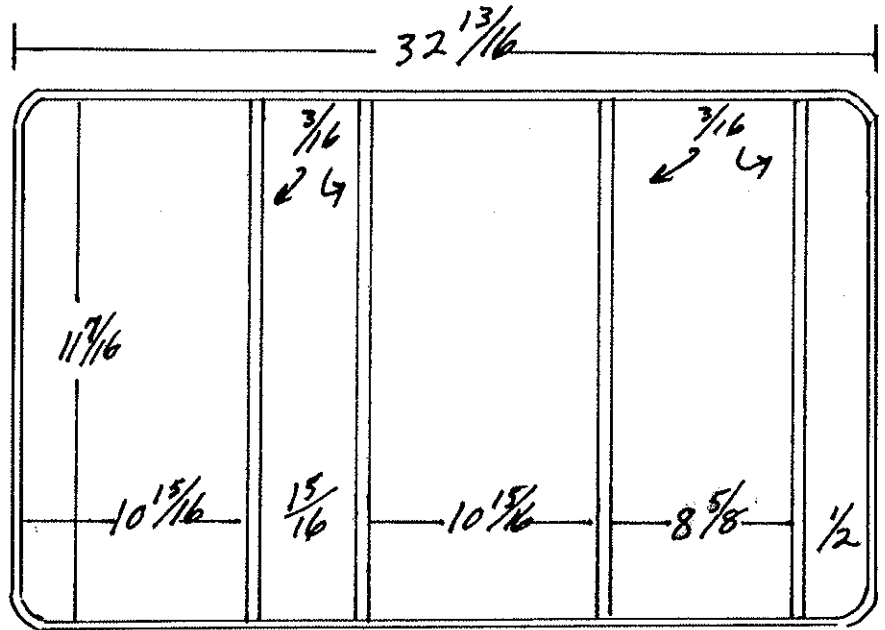

	Gauge	Thick
Tear Seal	<i>.016</i>	<i>3/32</i>
Bar Seal	<i>178</i>	<i>3/16</i>
Bar Seal		

	No. of Feet
Tear Seal	
Bar Seal	
Bar Seal	

Code	Ga.	# PCS	Cutting Specs		Code	Ga.	# Pcs.	Cutting Specs	
			Size	Out				Size	Out
Cover Mat.			<i>12 3/16</i>	<i>X 33 9/16</i>	Lining Mat.		<i>1</i>		
Cover Mat.			X		Lining Mat.		X		
Vert. Pckt.			X		Horz. Pckt.		X		
Vert. Rckt.			X		Horz. Pckt.		X		
Pocket			X		Pocket		X		
Label Holder			X		Card Holder		X		
Material			X		Material		X		
Material			X		Material		X		
Material			X		Material		X		
F.C. Board			<i>11 3/8</i>	<i>X 10 7/8</i>	B.C. Board		<i>1</i>		
B.C. Board			<i>11 3/8</i>	<i>X 8 9/16</i>	B.B. Board		<i>1</i>		
Center Board			X		Board		<i>1</i>		
Board			X		Strip		X		
Cover Pad			X		Strip		X		
					B.B. Pad		X		

Product Code

Style Case

PYRAMID CASE

Sheet Size $8\frac{1}{2}$ x 6

Cap. 1

Die No. 4410

Order No. 965218

Plate

N-N N. A. P&C GROUP

Customer

Metal
Total Vinyl
Quantity 500
Date 4-12-90
Type Corners
Radius
Completed

Gauge	Thick
Tear Seal 214	$\frac{1}{16}$ "
Bar Seal #	
Bar Seal	

No. of Feet	
Tear Seal	
Bar Seal	
Bar Seal	

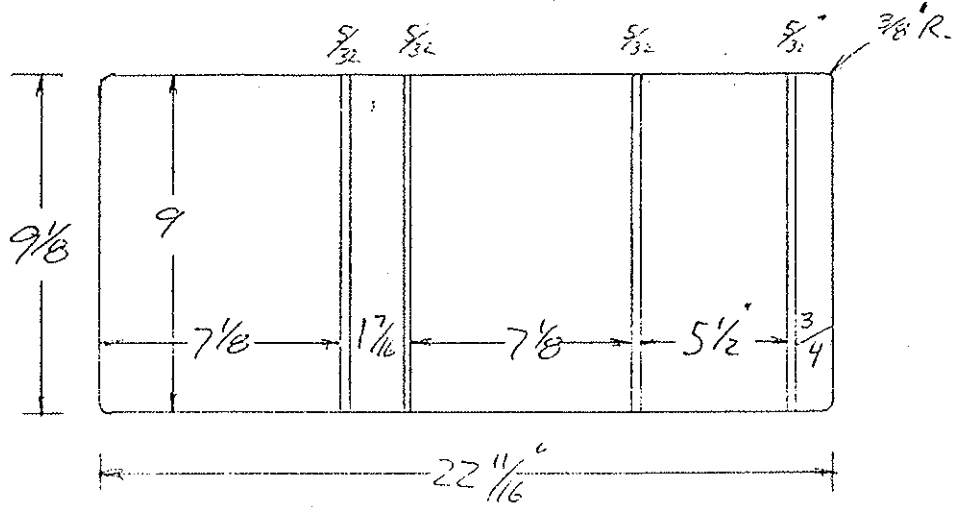

Spec. B. P. 110
 Check - KPV

Code		Cutting Specs		Code		Cutting Specs		
Ga.	Pcs	Size	Out	Ga.	Pcs	Size	Out	
Cover Mat.		$9\frac{3}{4}$ x $23\frac{1}{2}$	15	1	Lining Mat.	$9\frac{3}{4}$ x $23\frac{1}{2}$	15	1
Cover Mat.	X				Lining Mat.	X		
Vert. Pckt.	X				Horz. Pckt.	X		
Vert. Pckt.	X				Horz. Pckt.	X		
Pocket	X				Pocket	X		
Label Holder	X				Card Holder	X		
Material	X				Material	X		
Material	X				Material	X		
Material	X				Material	X		
F.C. Board		$8\frac{29}{32}$ x $7\frac{1}{32}$	100	1	F.C. Board			
B.G. Board		$8\frac{29}{32}$ x $7\frac{1}{32}$	100	1	B.B. Board	$8\frac{29}{32}$ x $1\frac{1}{32}$	100	1
Center Board	X				Board	$8\frac{29}{32}$ x $5\frac{13}{32}$	100	1
Board	X				Strip	$8\frac{29}{32}$ x $\frac{21}{32}$	100	1
Cover Pad	X				Strip	X		
					B.B. Pad	X		

Product Code

Style Case *PYRAMID CASE w/Velcro*

Sheet Size *8 1/2 X 7*

Cap. *1*

Die No. *4573 R*

Order No. *966890*

Plate

Customer	<i>FLORIDA POWER CORP.</i>
Metal	
Total Vinyl	
Quantity	<i>11-2-90</i>
Date	<i>1000</i>
Type Corners	
Radius	
Completed	

	Gauge	Thick
ear Seal	<i>1014</i>	<i>1/16</i>
ear Seal	<i>2541</i>	<i>3/32</i>
ear Seal	<i>1170</i>	<i>3/16</i>

	No. of Feet
ear Seal	
ear Seal	
ear Seal	

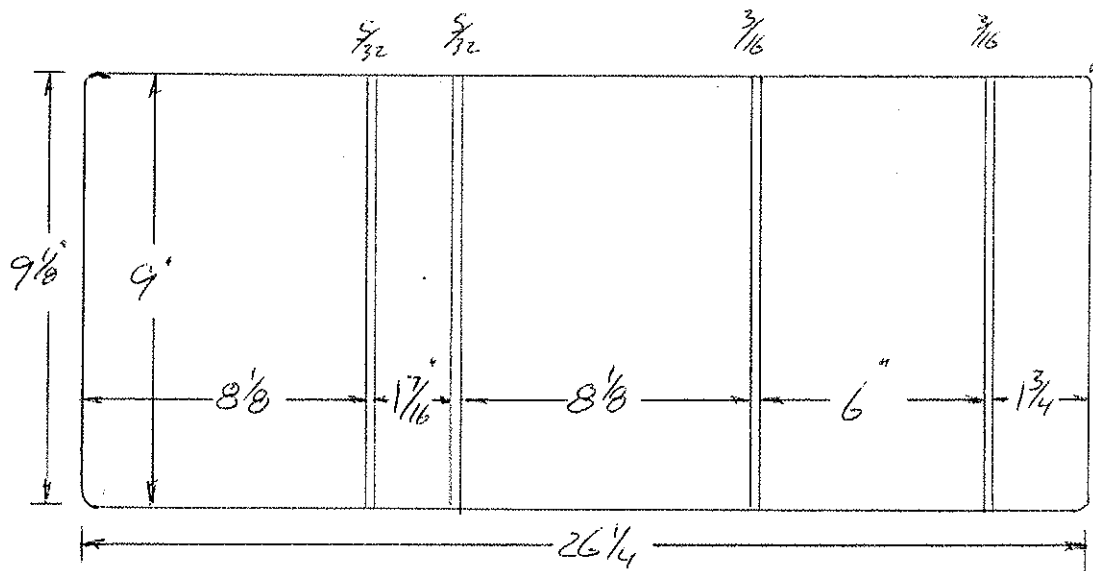

size - B.P.
check.

Code	Cutting Specs				Code	Cutting Specs					
	Ga.	# PCS	Size	Out		Ga.	# Pcs.	Size	Out		
cover Mat.			<i>9 3/4 X 27</i>	<i>15</i>	<i>1</i>	Lining Mat.			<i>9 3/4 X 27</i>	<i>15</i>	<i>1</i>
cover Mat			X			Lining Mat.			X		
vert. Pckt.			X			Horz. Pckt.			X		
vert. Rckt.			X			Horz. Pckt	<i>POLISHED</i>		<i>4 7/8 X 18 9/16</i>	<i>8</i>	<i>1</i>
Pocket			X			Pocket			X		
label Holder			X			Card Holder			X		
Material	<i>POLISHED</i>		<i>9 1/4 X 10 1/2</i>	<i>8</i>	<i>1</i>	Material			X		
Material			X			Material			X		
Material			X			Material			X		
B.C. Board			<i>8 29/32 X 8 1/32</i>	<i>100</i>	<i>1</i>	B.C. Board			<i>8 29/32 X 5 29/32</i>	<i>100</i>	<i>1</i>
B.C. Board			<i>8 29/32 X 8 1/32</i>	<i>100</i>	<i>1</i>	B.B. Board			<i>8 29/32 X 1 11/32</i>	<i>100</i>	<i>1</i>
center Board			X			Board			<i>8 29/32 X 1 21/32</i>	<i>100</i>	<i>1</i>
Board					<i>1</i>	Strip			X		
cover Pad			X			Strip			X		
						B.B. Pad			X		

Product Code

Style Case PYRAMID CASE

Sheet Size 11 X 9

Cap. 1/2

Die No. 4668

Order No. 967864

Plate C-11-5

PRUDENTIAL LIFE INSURANCE

Customer	
Material	
Total Vinyl	
Quantity	600
Date	2-21-91
Type Corners	
Radius	3/8
Completed	

	Gauge	Thick
ear Seal	.014	1/16
ar Seal	.7254	5/32
ar Seal		

	No. of Feet
ear Seal	
ar Seal	
ar Seal	

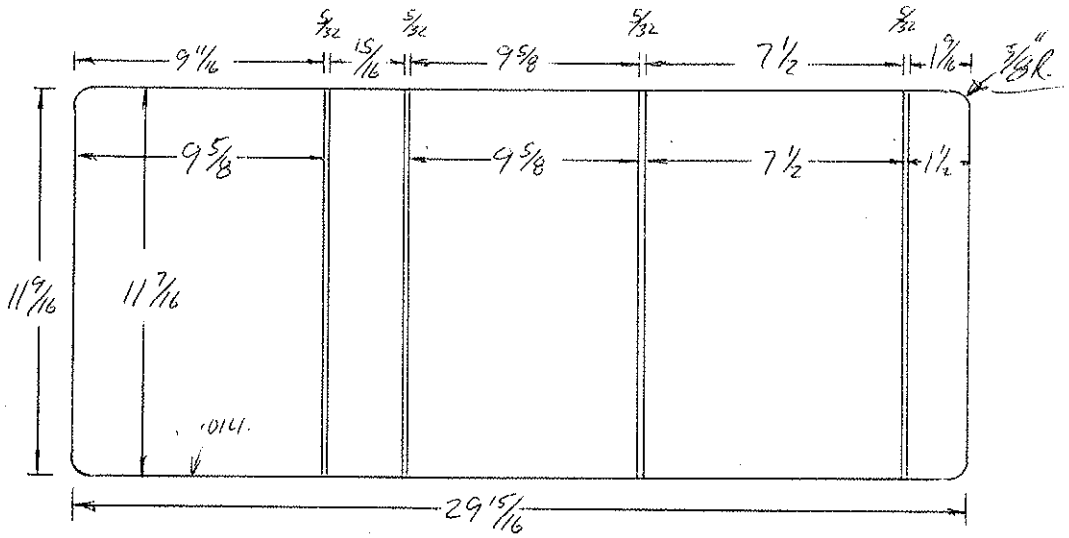

SIZE B.PACE

CHECK-

Code	Ga.	PCS	Cutting Specs		Code	Ga.	Pcs.	Cutting Specs	
			Size	Out				Size	Out
Over Mat.		12 1/4 X 31	14	1	Lining Mat.		12 1/4 X 31	14	1
Over Mat		X			Lining Mat.		X		
Int. Pckt.		X			Horz. Pckt.		X		
Int. Pckt.		X			Horz. Pckt.		X		
Pocket	COL FC	11 11/16 X 10 1/8			Pocket		X		
Label Holder		X			Card Holder		X		
Material		X			Material	12 X 4 X 2 1/4	16 ga Resid clear	1	
Material		X			Material		X		
Material		X			Material		X		
B.C. Board	ROUND CORNER	11 11/32 X 9 17/32	100	1	B.C. Board		X		
B.C. Board	SQ.	11 11/32 X 9 17/32	100	1	B.B. Board	11 11/32 X 2 7/32	100	1	
Enter Board		X			Board	ROUND CORNER 11 11/32 X 1 13/32	100	1	
Board	SQ.	11 11/32 X 7 13/32	100	1	Strip		X		
Over Pad		X			Strip		X		
					B.B. Pad		X		

Product Code

Style Case PYRAMID EASLE VR3

Sheet Size 11 x 9

Cap. 3' ROUND

Die No. 4675

Order No. 967981

Plate K-2-2

ADTRAN

Customer	
Material	
Total Vinyl	
Quantity	<u>50</u>
Date	<u>2-28-91</u>
Type Corners	
Radius	<u>3/8" R.</u>
Completed	

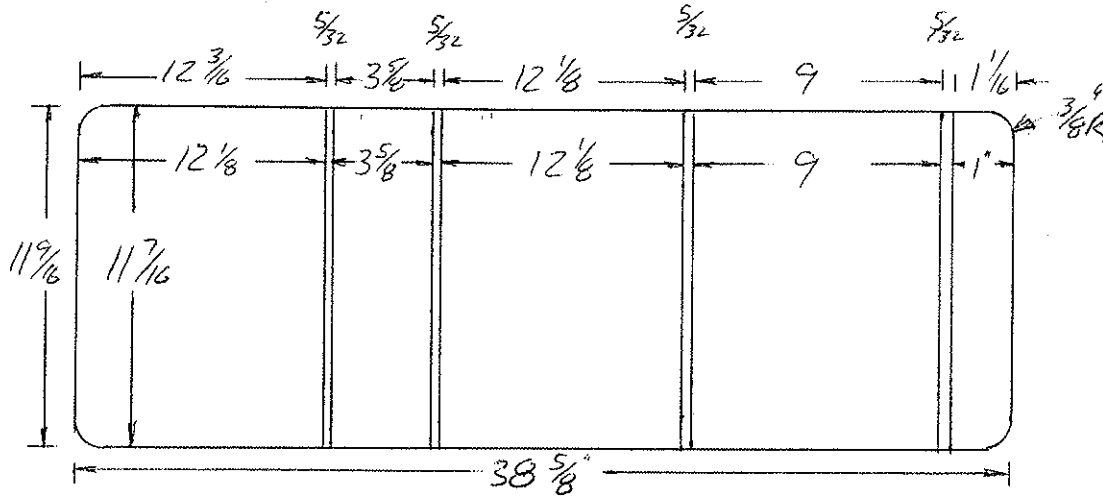

	Gauge	Thick
ear Seal	<u>.014</u>	<u>1/16</u>
ar Seal	<u>#254</u>	<u>3/32</u>
ar Seal		

	No. of Feet
ear Seal	
ar Seal	
ar Seal	

SIZE - B. Pace

CHECK - KPV

Code	Ga.	# PCS	Cutting Specs		Code	Ga.	# Pcs.	Cutting Specs	
			Size	# Out				Size	# Out
Over Mat.			<u>12 1/4</u>	<u>X 39 1/2</u>		<u>14</u>	<u>1</u>		
Over Mat.					Lining Mat.				
Over Mat.					Lining Mat.				
Art. Pckt.					Horz. Pckt.				
Art. Pckt.					Horz. Pckt.				
Pocket					Pocket				
Label Holder					Card Holder				
Material					Material				
Material					Material				
Material					Material				
B.C. Board	<u>R.C.</u>		<u>11 1/32</u>	<u>X 12 1/32</u>	B.C. Board				
B.C. Board	<u>SQ.</u>		<u>11 1/32</u>	<u>X 12 1/32</u>	B.B. Board	<u>SQ.</u>			
Enter Board	<u>SQ.</u>		<u>11 1/32</u>	<u>X 8 29/32</u>	Board	<u>R.C.</u>			
Board					Strip				
Over Pad					Strip				
					B.B. Pad				

Product Code

Style Case Pyramid Easel

Sheet Size 11 X 9 Cap. 1 1/2 Die No. 5188-R Order No. 973697.1 Plate D13-2

Miller-Reid INC

11-6

Customer	
Material	
Material Vinyl	
Quantity	36
Date	10-22-92
Type Corners	RND
Radius	3/8
Completed	

	Gauge	Thick
Bar Seal	.014	7/16
Tr Seal	253	1/8
Tr Seal		

	No. of Feet
Bar Seal	
Tr Seal	
Tr Seal	

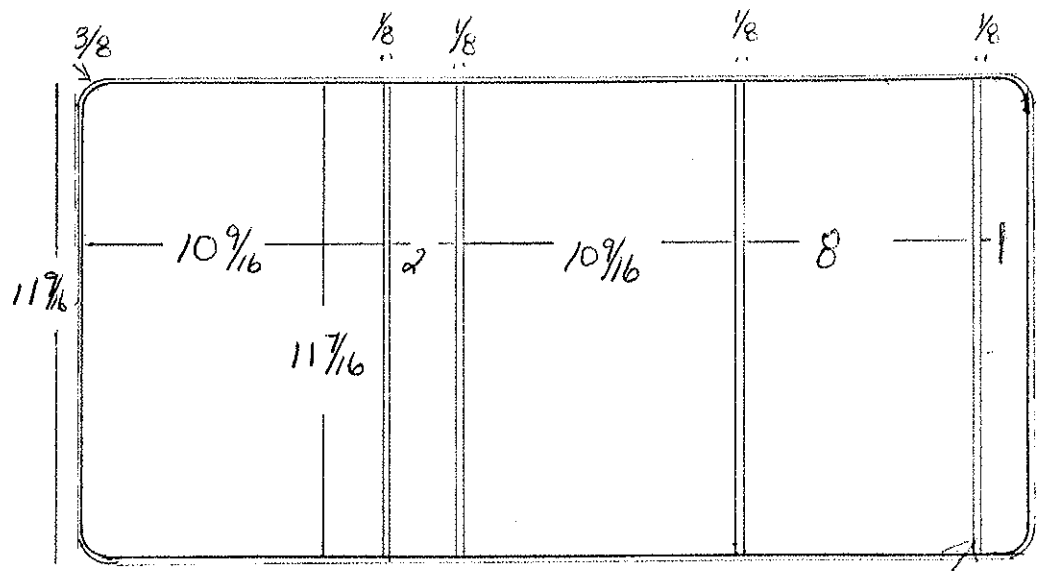

Tim

32 3/4

BAR moved 1/2" TO INCREASE FEET BREADTH

Code		Cutting Specs				Code		Cutting Specs			
		Ga.	# PCS	Size	Out			Ga.	# Pcs.	Size	Out
Over Mat.	12 5/16 X 33 1/2		1			Lining Mat.	12 5/16 X 33 1/2		1		
Over Mat	X					Lining Mat.	X				
Horz. Pckt.	X					Horz. Pckt.	X				
Horz. Pckt.	X					Horz. Pckt.	X				
Pocket	X					Pocket	X				
Card Holder	X					Card Holder	X				
Material	X					Material	12 5/16 X 3 1/4		1		
Material	X					Material	X				
Material	X					Material	X				
B.C. Board Rnd.	11 1/32 X 10 15/32	120	1			B.C. Board	X				
B.C. Board Sq.	11 1/32 X 7 21/32	120	1			B.B. Board	X				
Center Board Sq.	11 1/32 X 10 15/32	120	1			Board	X				
BB Board	11 1/32 X 1 21/32	120	1			Strip	X				
Over Pad	X					Strip	X				
Foot Board Rnd.	11 1/32 X 2 1/32	120	1			B.B. Pad	X				

Product Code

Style Case Presentation Easel

Sheet Size 9 X 10 Cap.

Die No. 5275

Order No. 9744081

Plate D16.4

Mandell Premium Corp.

2.5

Customer	
etal	
otal Vinyl	
quantity	
ate	2.3-93
ype Corners	Sg
adius	0.9
ompleted	

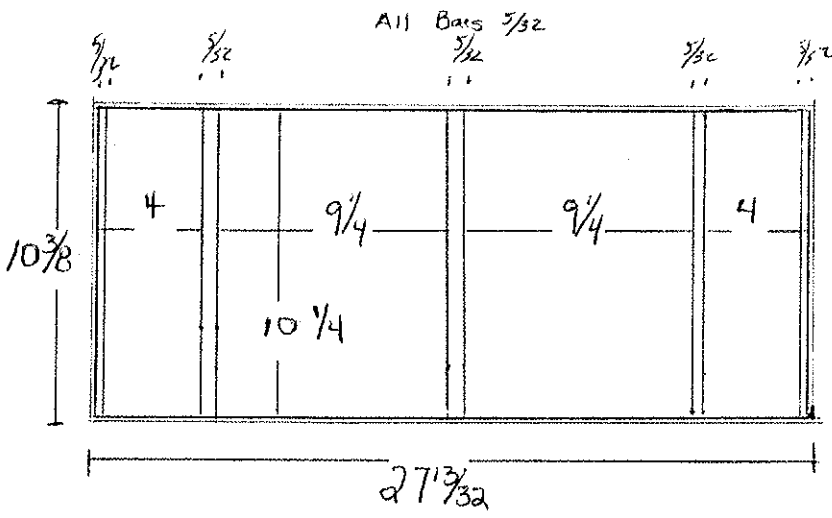

	Gauge	Thick
ear Seal		
ar Seal	254	3/32
ar Seal	.012	1/16

	No. of Feet
ear Seal	
ar Seal	
ar Seal	

Tim

Code	Ga.	#	PCS	Cutting Specs.		Code	Ga.	#	Pcs.	Cutting Specs.	
				Size	Out					Size	Out
over Mat.			1			Lining Mat.			1		
over Mat						Lining Mat.					
rt. Pckt.			1			Horz. Pckt.					
rt. Pckt.						Horz. Pckt.					
ocket						Pocket					
bel Holder						Card Holder					
aterial						Material					
aterial						Material					
aterial						Material					
C. Board			2			B.C. Board			2		
C. Board						B.B. Board					
nter Board						Board					
ard						Strip					
ver Pad						Strip					
						B.B. Pad					

NB-D

DIE # 5538	STYLE CASE VRB EASEL	LOCATION M6-9
SHEET SIZE 11 3/4 X 8 3/4	CAP. 2	ORDER # 978365
CUSTOMER FAHEY AND ASSOCIATES	DUE DATE 6-3	
QUANTITY	RADUS	TEAM LEAD
DATE	COMPLETED	BAR SEAL

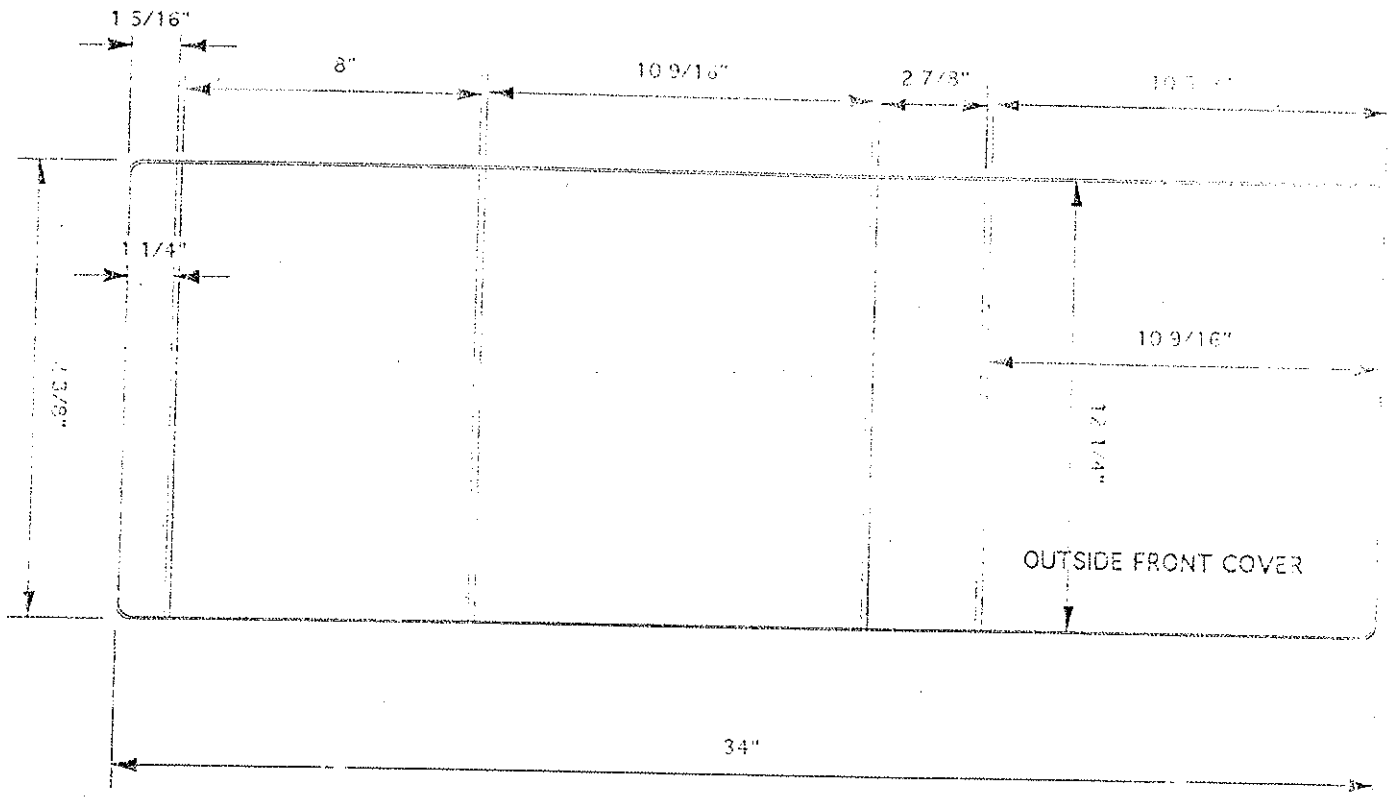

MATERIAL SPEC

GA PCS

GA PCS

COVER MATL	13 1/8 X 34 3/4	1	LINING	13 1/8 X 34 3/4	1
COVER MATL			LINING		
VERT PKT			HORZ PKT		
VERT PKT			HORZPKT		
CARD HOLDER			DIAGONAL PKT		
COL			LABEL HOLDER		
EX COL			GUSSETT		
			REINF		

BOARD SPECS

F.C. BOARD	12 5/32 X 10 15/32	120	1	F.C. BOARD		
B.B. BOARD	12 5/32 X 2 25/32	120	1	B.B. BOARD		
B.C. BOARD	12 5/32 X 10 15/32	120	1	B.C. BOARD		
BU STRIP	12 5/32 X 7 29/32	120	1			
	12 5/32 X 1 5/32	120	1			

DIE #	7539	METAL	LOC	RADIUS	3/8"
ORDER #	577643	CUSTOMER		TEAR SEAL	.012
SHEET SIZE	11 X 9	STYLE CASE	VINYL FOOTED EASEL	BAR SEAL	5/32"
CAP.	1"	DUE DATE		COMPLETED	
LOCATION		QUANTITY		DATE	9-24-03

THIS IS A MODIFIED VERSION OF DIE 4358-R2.
ALL BARS CHANGED TO 5/32". 4358-R2 WILL
BE SAVED FOR HOME INTERIOR REPEATS.

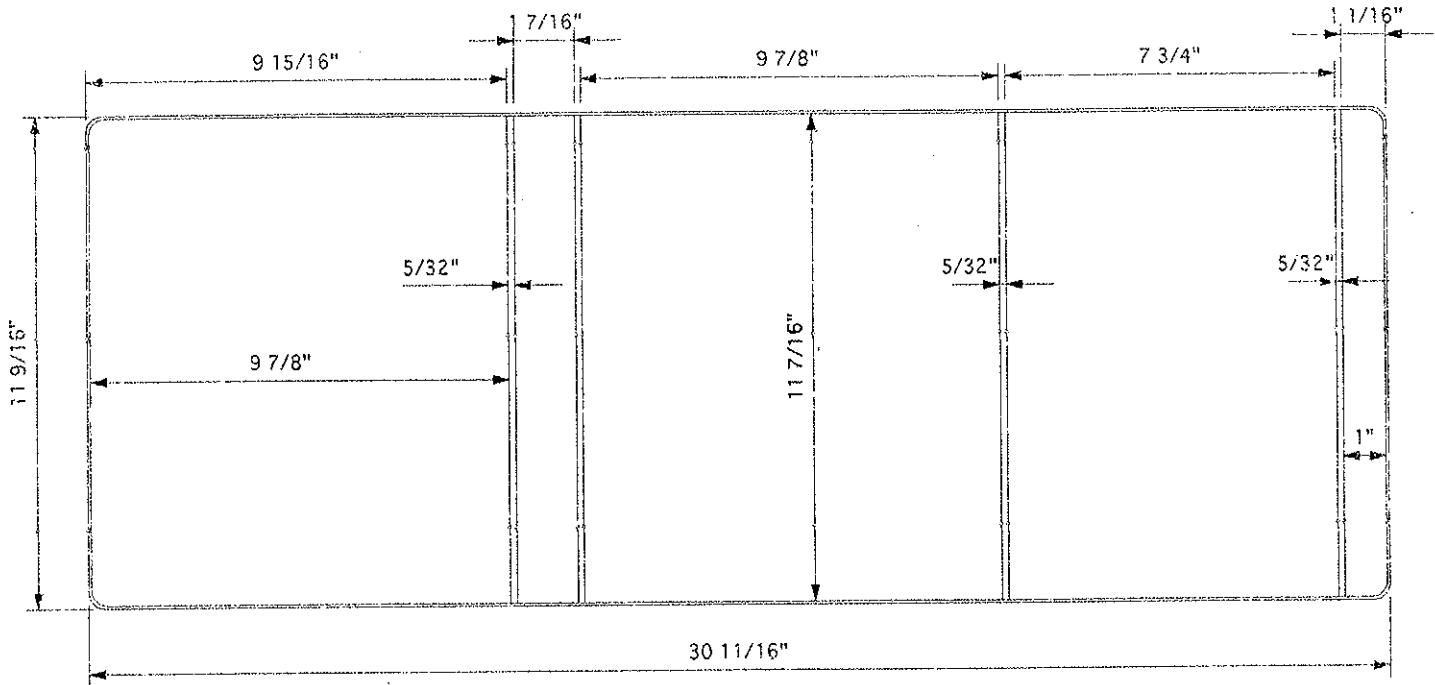

MATERIAL SPECS		GAUGE	PCS.	MATERIAL SPECS		GAUGE	PCS.
COVER MAT.	12 9/16 X 31 3/4		1	LINING MAT.	12 5/16 X 31 3/4		1
COVER MAT.				LINING MAT.			
DIE CUT				HORZ. PKT.	4 7/8 x 22 1/8		
COL				VERT. PKT.			
LABEL HOLDER				DIE CUT			
GUSSET				REINF.	12 5/16 X 3	16ga	1
BOARD SPECS		GAUGE	PCS.	BOARD SPECS		GAUGE	PCS.
5/16" R. CORNERS				5/16" R. CORNERS			
F.C. BOARD	11 3/8 X 9 13/16	100	1	F.C. BOARD	Padded Bd 7539 B - FC-BB-BC		
B.B. BOARD	11 3/8 X 1 11/32	135	1	B.B. BOARD	14 3/16 x 21		
B.C. BOARD	11 3/8 X 9 13/16	100	1	B.C. BOARD			
FLAP BD.	11 3/8 X 29/32	100	1	DIE CUT			
BOARD	11 3/8 X 7 11/16	100	1	DIE CUT			

DIE #	7551-A-B	METAL	LOC	RADIUS	3/8"
ORDER #	582400	CUSTOMER	GERRY EDWARDS	TEAR SEAL	.014
SHEET SIZE	8 1/2 X 11 1/2	STYLE CASE	VINYL FOOTED EASEL	BAR SEAL	FLAT
CAP.	1"	DUE DATE	10-31-03	COMPLETED	
LOCATION		QUANTITY	1500	DATE	10-16-03

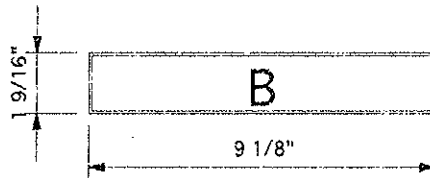
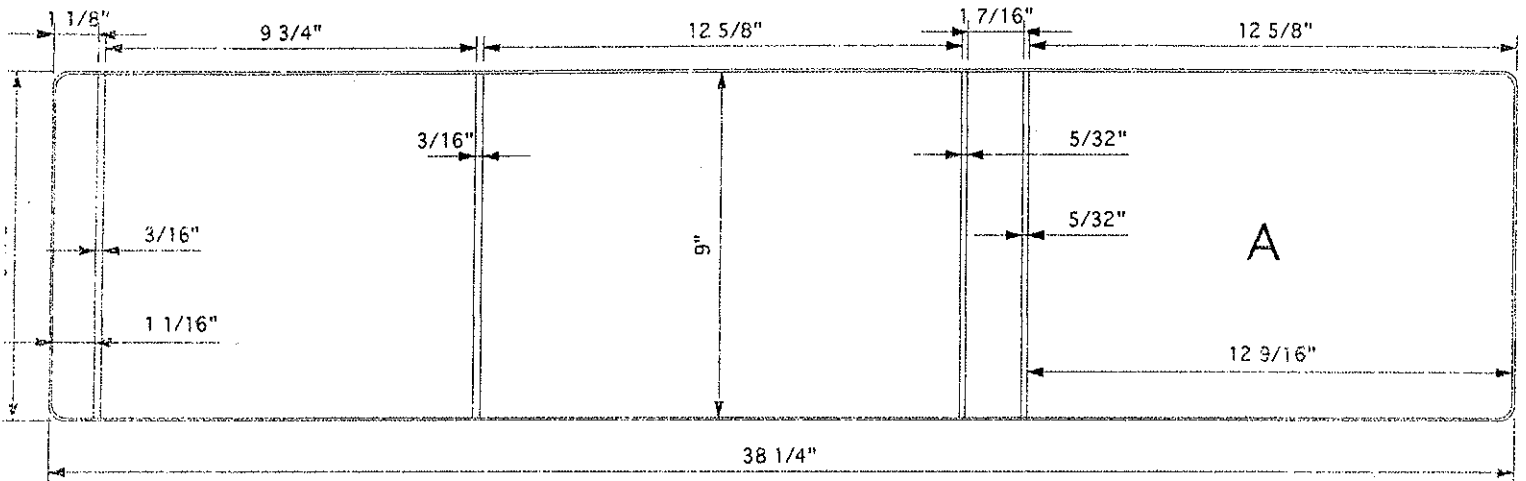

MATERIAL SPECS		GAUGE	PCS.	MATERIAL SPECS		GAUGE	PCS.
COVER MAT.	9 7/8 X 39 1/4	A	1	LINING MAT.	9 7/8 X 39 1/4	A	1
COVER MAT.	9 7/8 X 2 1/4	B	1	LINING MAT.	9 7/8 X 2 1/4	B	1
DIE CUT				HORZ. PKT.	9 7/8 X 12	A	1
COL				VERT. PKT.			
LABEL HOLDER				DIE CUT			
GUSSET				REINF.			
BOARD SPECS		5/16" R. CORNERS		BOARD SPECS		5/16" R. CORNERS	
F.C. BOARD	8 15/16 X 12 1/2	A	100	F.C. BOARD			
B.B. BOARD	8 15/16 X 1 11/32	A	100	B.B. BOARD	8 15/16 X 1 7/16	100	1
B.C. BOARD	8 15/16 X 12 9/16	A	100	B.C. BOARD			
FLAP BD.	8 15/16 X 31/32	A	100	DIE CUT			
BOARD	8 15/16 X 9 11/16	A	100	DIE CUT			

Pyramid

DIE #	7598	METAL	LOC NB	RADIUS	3/8"
ORDER #	595331	CUSTOMER	JC PENNY	TEAR SEAL	.012
SHEET SIZE	11 X 9	STYLE CASE	VINYL EASEL	BAR SEAL	178
CAP.	3/4"	DUE DATE	1-16-04	COMPLETED	
LOCATION		QUANTITY	650	DATE	12-31-03

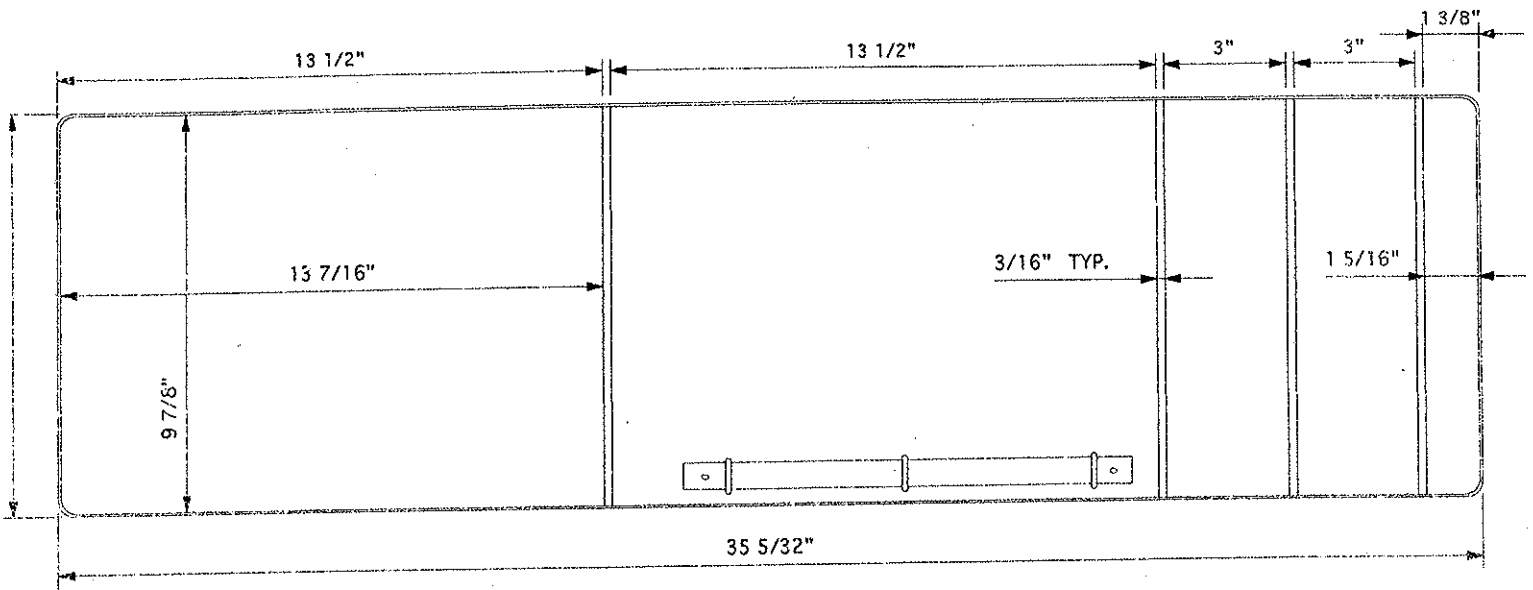

OUTSIDE VIEW

MATERIAL SPECS		GAUGE	PCS.	MATERIAL SPECS	GAUGE	PCS.	
COVER MAT.	10 3/4 X 36 1/8		1	LINING MAT.	10 3/4 X 36 1/8	1	
COVER MAT.				LINING MAT.			
DIE CUT				HORZ. PKT.			
COL				VERT. PKT.			
LABEL HOLDER				DIE CUT			
GUSSET				REINF.			
BOARD SPECS	5/16" R. CORNERS	GAUGE	PCS.	BOARD SPECS	5/16" R. CORNERS	GAUGE	PCS.
F.C. BOARD	9 13/16 X 13 3/8	98	1	F.C. BOARD			
B.B. BOARD	9 13/16 X 1 7/32	98	1	B.B. BOARD			
B.C. BOARD	9 13/16 X 13 7/16	98	1	B.C. BOARD			
FLAP BD.				DIE CUT			
BOARD	9 13/16 X 2 29/32	98	2	DIE CUT			

DIE #	7660	METAL	LOC	RADIUS	3/8"
ORDER #	613616	CUSTOMER	AJ BART	TEAR SEAL	.016
SHEET SIZE	11 X 9	STYLE CASE	VINYL TENT EASEL	BAR SEAL	48-4-178
CAP.	1/2"	DUE DATE	4-15-04	COMPLETED	
LOCATION		QUANTITY	50	DATE	3-31-04

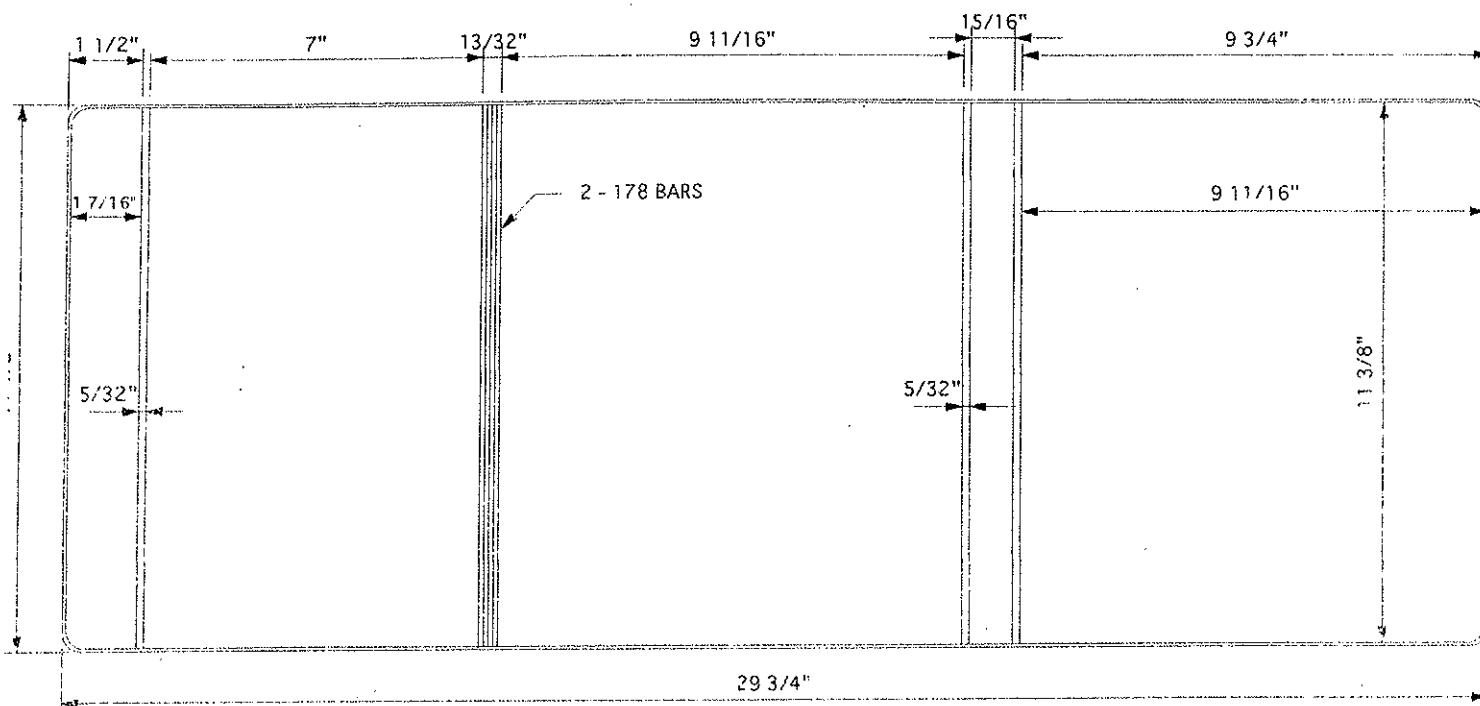

MATERIAL SPECS		GAUGE	PCS.	MATERIAL SPECS		GAUGE	PCS.
COVER MAT.	12 1/2 X 30 3/4		1	LINING MAT.	12 1/4 X 30 1/2		1
COVER MAT.				LINING MAT.			
DIE CUT				HORZ. PKT.			
COL				VERT. PKT.			
LABEL HOLDER				DIE CUT			
GUSSET				REINF.	12 1/4 X 2 5/16	CLEAR	1
BOARD SPECS		5/16" R. CORNERS		BOARD SPECS		5/16" R. CORNERS	
F.C. BOARD	11 9/32 X 9 19/32	100	1	F.C. BOARD			
B.B. BOARD	11 9/32 X 27/32	100	1	B.B. BOARD			
B.C. BOARD	11 9/32 X 9 19/32	100	1	B.C. BOARD			
FLAP BD.	11 9/32 X 1 11/32	100	1	DIE CUT			
BOARD	11 9/32 X 6 29/32	100	1	DIE CUT			

DIE #	7670	METAL	LOC	RADIUS	3/8"
ORDER #	616147	CUSTOMER	VALLEY INDEPENDENT BANK	TEAR SEAL	.016
SHEET SIZE	11 X 9 3/4	STYLE CASE	VINYL FOOTED / TENT EASEL	BAR SEAL	
CAP.	1"	DUE DATE	4-16-04	COMPLETED	
LOCATION		QUANTITY	300	DATE	4-12-04

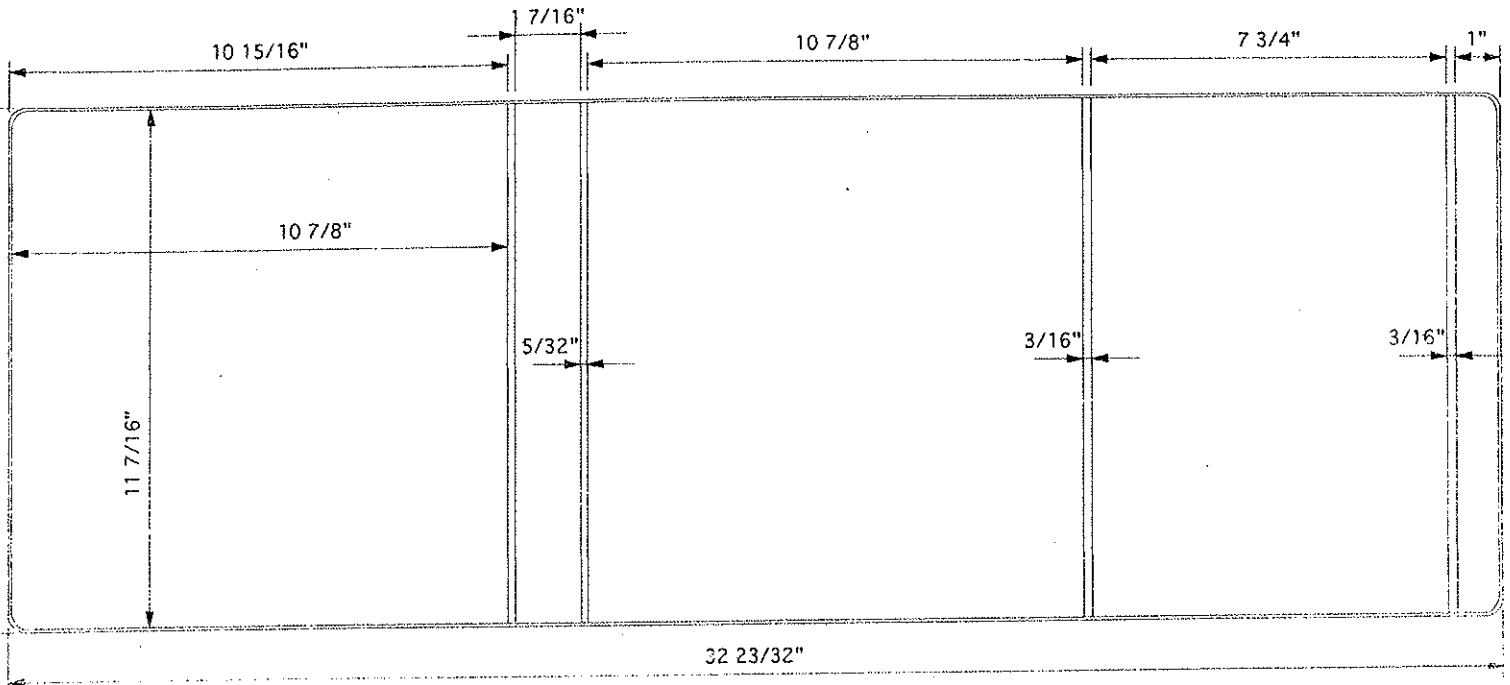

MATERIAL SPECS		GAUGE	PCS.	MATERIAL SPECS		GAUGE	PCS.
COVER MAT.	12 9/16 X 33 3/4	CAST.	1	LINING MAT.	12 5/16 X 33 1/2	CAST.	1
COVER MAT.				LINING MAT.			
DIE CUT				HORZ. PKT.			
COL				VERT. PKT.			
LABEL HOLDER				DIE CUT			
GUSSET				REINF.	12 9/16 X 2 3/4	CLEAR	1

BOARD SPECS		GAUGE	PCS.	BOARD SPECS		GAUGE	PCS.
5/16" R. CORNERS				5/16" R. CORNERS			
F.C. BOARD	11 11/32 X 10 25/32	100	1	F.C. BOARD			
B.B. BOARD	11 11/32 X 1 11/32	100	1	B.B. BOARD			
B.C. BOARD	11 11/32 X 10 25/32	100	1	B.C. BOARD			
FLAP BD.	11 11/32 X 7 21/32	100	1	DIE CUT			
BOARD	11 11/32 X 27/32	100	1	DIE CUT			

DIE #	7714	METAL	RR	RADIUS	3/8"
ORDER #	629992	CUSTOMER	ADVANCE LOOSELEAF	TEAR SEAL	.014
SHEET SIZE	8 1/2 X 6	STYLE CASE	VINYL PYRAMID EASEL	BAR SEAL	FLAT
CAP.	2 1/2"	DUE DATE	7-27-04	COMPLETED	
LOCATION		QUANTITY	1000	DATE	7-2-04

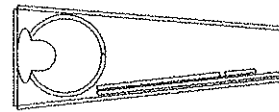
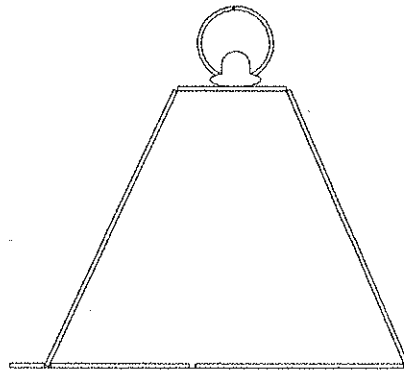
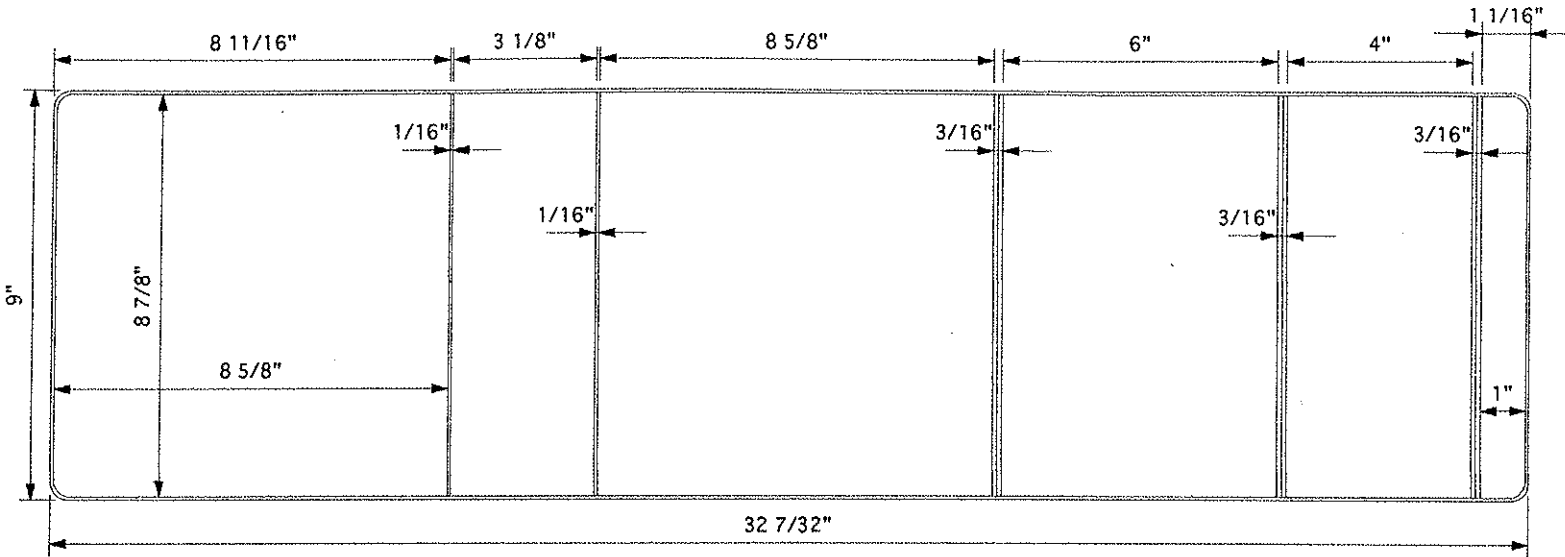

MATERIAL SPECS		GAUGE	PCS.	MATERIAL SPECS		GAUGE	PCS.				
COVER MAT.	9 3/4 x 33		1	LINING MAT.	9 3/4 x 33		1				
COVER MAT.				LINING MAT.							
DIE CUT				HORZ. PKT.							
COL	9 1/8 x 9 1/8		1	VERT. PKT.							
LABEL HOLDER				DIE CUT							
GUSSET				REINF.							
BOARD SPECS		5/16" R. CORNERS		GAUGE	PCS.	BOARD SPECS		5/16" R. CORNERS		GAUGE	PCS.
F.C. BOARD	8 25/32 x 8 17/32	120	1	F.C. BOARD	8 25/32 x 3 29/32	120	1				
B.B. BOARD	8 25/32 x 3 1/32	120	1	B.B. BOARD							
B.C. BOARD	8 25/32 x 8 17/32	120	1	B.C. BOARD							
FLAP BD.	8 25/32 x 7/8	120	1	DIE CUT							
BOARD	8 25/32 x 5 29/32	120	1	DIE CUT							

DIE #	7724	METAL	RR	RADIUS	3/8"
ORDER #	632171	CUSTOMER	ALPHAGRAPHS 161	TEAR SEAL	.014
SHEET SIZE	14 X 11 1/4	STYLE CASE	VINYL TENT EASEL	BAR SEAL	
CAP.	1"	DUE DATE	8-10-04	COMPLETED	
LOCATION		QUANTITY	25	DATE	7-20-04

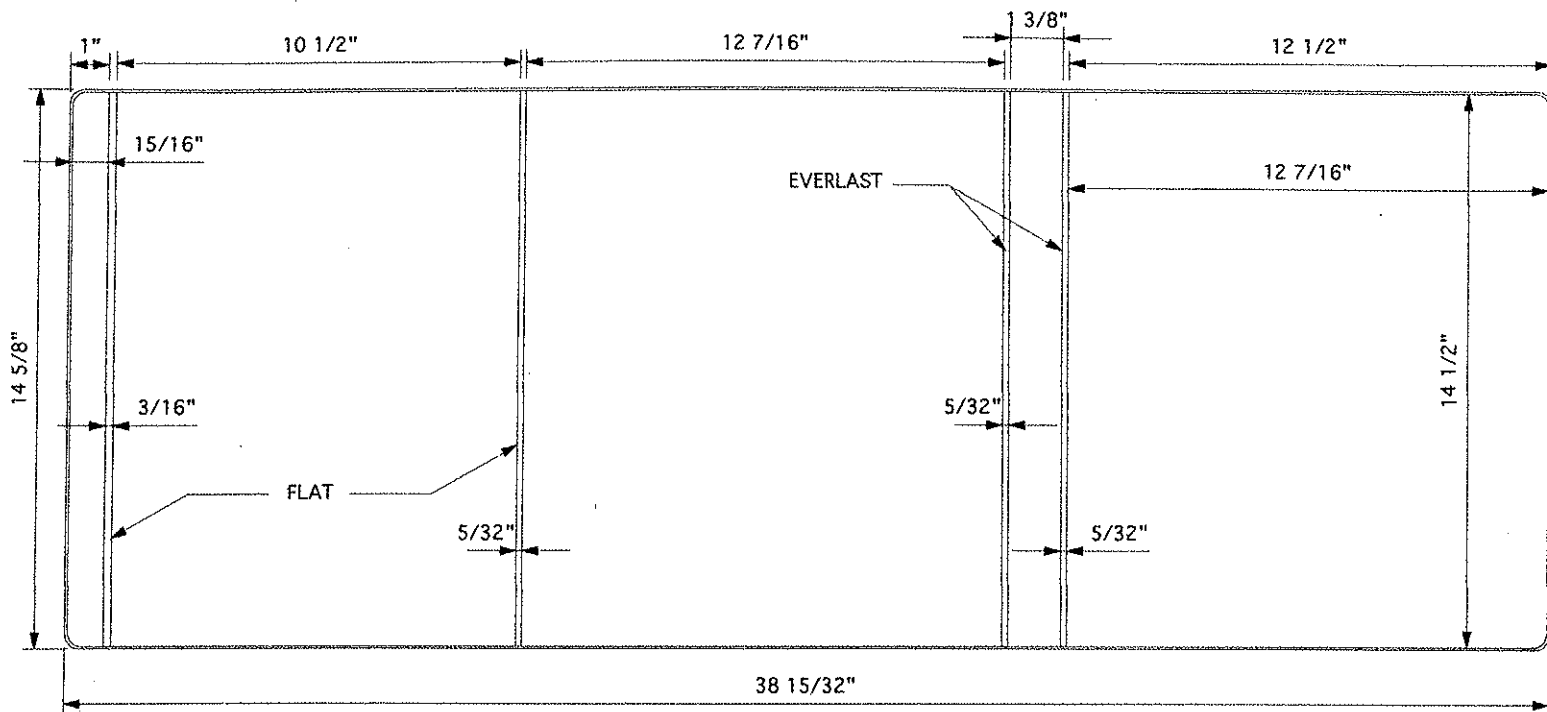

MATERIAL SPECS		GAUGE	PCS.	MATERIAL SPECS		GAUGE	PCS.
COVER MAT.	15 5/8 X 39 1/2		1	LINING MAT.	15 3/8 X 39 1/4		1
COVER MAT.				LINING MAT.			
DIE CUT				HORZ. PKT.			
COL				VERT. PKT.			
LABEL HOLDER				DIE CUT			
GUSSET				REINF.	15 3/8 X 2 1/4	CLEAR	1
BOARD SPECS		GAUGE	PCS.	BOARD SPECS		GAUGE	PCS.
F.C. BOARD	14 13/32 X 12 11/32	100	1	F.C. BOARD			
B.B. BOARD	14 13/32 X 1 9/32	100	1	B.B. BOARD			
B.C. BOARD	14 13/32 X 12 11/32	100	1	B.C. BOARD			
FLAP BD.	14 13/32 X 10 13/32	100	1	DIE CUT			
BOARD	14 13/32 X 27/32	100	1	DIE CUT			

DIE #	7877	METAL	RR W/B	RADIUS	3/8"
ORDER #	674865	CUSTOMER	GRABOWSKI & CO	TEAR SEAL	.014
SHEET SIZE	11 X 9	STYLE CASE	VINYL PYRAMID EASEL	BAR SEAL	
CAP.	2"	DUE DATE	5-10-05	COMPLETED	
LOCATION		QUANTITY	50	DATE	4-27-05

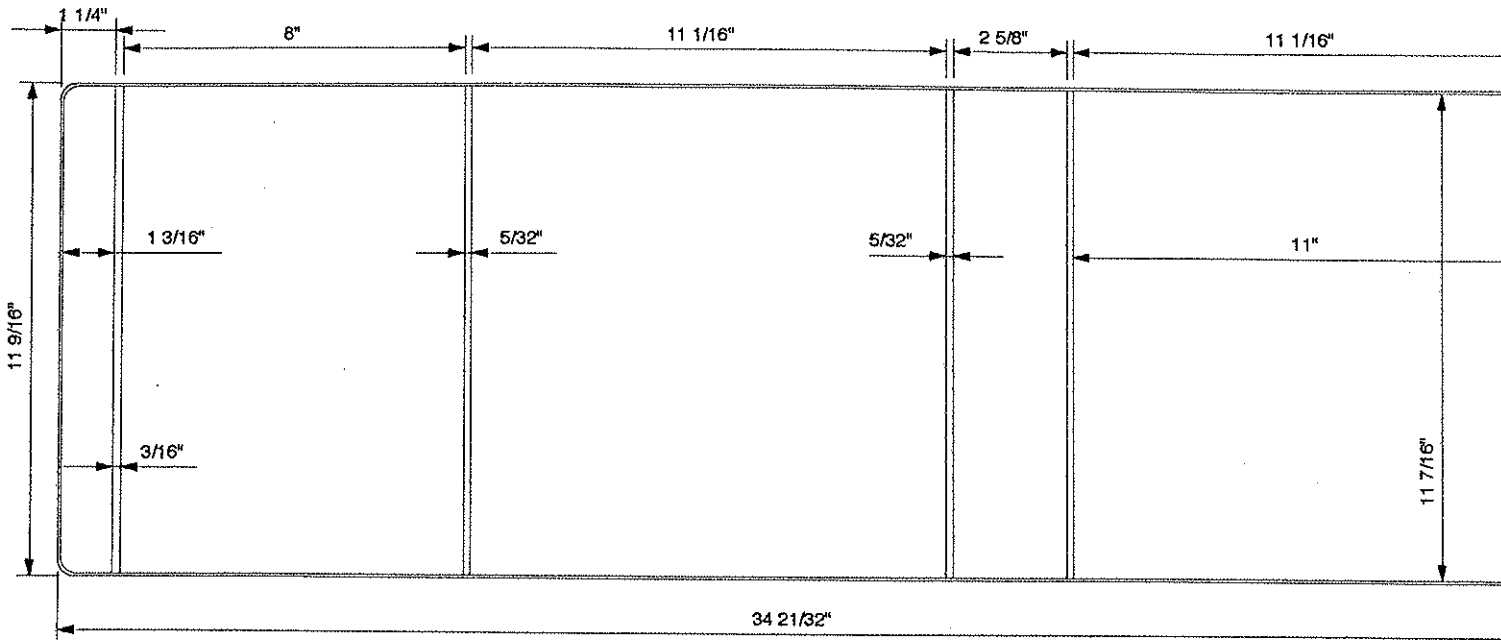

MATERIAL SPECS		GAUGE	PCS.	MATERIAL SPECS		GAUGE	PCS.
COVER MAT.	12 1/4 X 35 1/2		1	LINING MAT.	12 1/4 X 35 1/2		1
COVER MAT.				LINING MAT.			
DIE CUT				HORZ. PKT.			
COL				VERT. PKT.			
LABEL HOLDER				DIE CUT			
GUSSET				REINF.			
BOARD SPECS		5/16" R. CORNERS		BOARD SPECS		5/16" R. CORNERS	
F.C. BOARD	11 3/8 X 10 15/16	120	1	F.C. BOARD			
B.B. BOARD	11 3/8 X 2 17/32	120	1	B.B. BOARD			
B.C. BOARD	11 3/8 X 11	120	1	B.C. BOARD			
FLAP BD.	11 3/8 X 1 3/32	120	1	DIE CUT			
BOARD	11 3/8 X 7 29/32	120	1	DIE CUT			

DIE #	7971	METAL	RR N/B	RADIUS	3/8"
ORDER #	690638	CUSTOMER	CURTIS 1000	TEAR SEAL	.014
SHEET SIZE	7 X 5 1/2	STYLE CASE	VINYL PYRAMID EASEL	BAR SEAL	FLAT
CAP.	2"	DUE DATE	8-31-05	COMPLETED	
LOCATION		QUANTITY	250	DATE	8-24-05

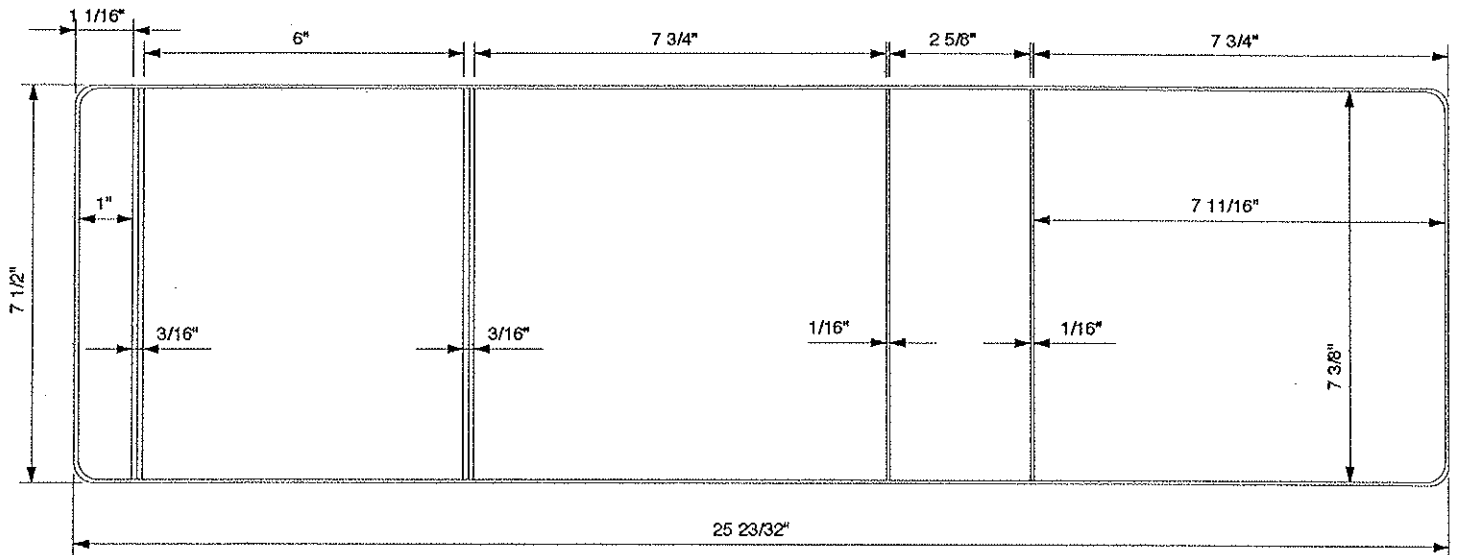

MATERIAL SPECS		GAUGE	PCS.	MATERIAL SPECS		GAUGE	PCS.
COVER MAT.	8 1/4 X 26 1/2		1	LINING MAT.	8 1/4 X 26 1/2		1
COVER MAT.				LINING MAT.			
DIE CUT				HORZ. PKT.			
COL				VERT. PKT.			
LABEL HOLDER				DIE CUT			
GUSSET				REINF.			

BOARD SPECS		5/16" R. CORNERS		GAUGE	PCS.	BOARD SPECS		5/16" R. CORNERS		GAUGE	PCS.
F.C. BOARD	7 5/16 X 7 5/8	120	1	F.C. BOARD							
B.B. BOARD	7 5/16 X 2 17/32	120	1	B.B. BOARD							
B.C. BOARD	7 5/16 X 7 11/16	120	1	B.C. BOARD							
FLAP BD.	7 5/16 X 29/32	120	1	DIE CUT							
BOARD	7 5/16 X 5 15/16	120	1	DIE CUT							

DIE #	8038	METAL	RR	RADIUS	3/8"
ORDER #	709407	CUSTOMER	HILLTOP PRESS	TEAR SEAL	.014
SHEET SIZE	11 1/4 X 10 1/2	STYLE CASE	VINYL PYRAMID EASEL	BAR SEAL	EVERLAST
CAP.	1"	DUE DATE	12-9-05	COMPLETED	
LOCATION		QUANTITY	1	DATE	12-8-05

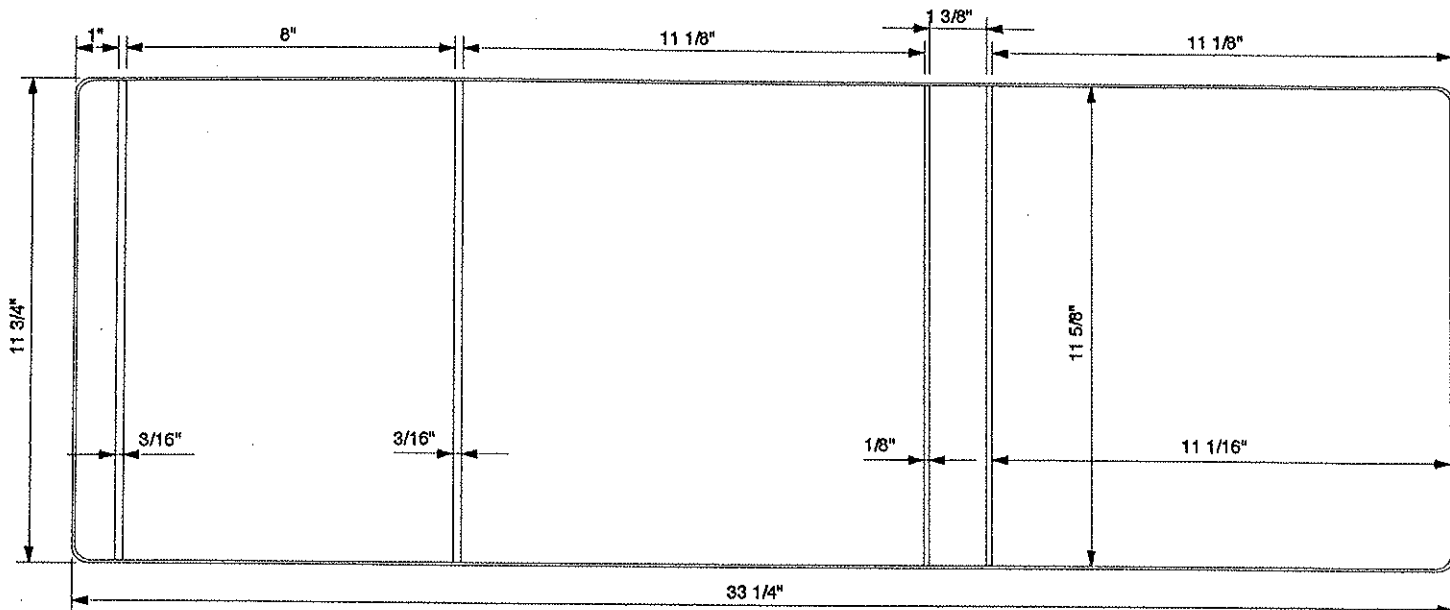

MATERIAL SPECS		GAUGE	PCS.	MATERIAL SPECS		GAUGE	PCS.
COVER MAT.	12 3/4 X 34 1/4		1	LINING MAT.	12 1/2 X 34		1
COVER MAT.				LINING MAT.			
DIE CUT				HORZ. PKT.			
COL				VERT. PKT.			
LABEL HOLDER				DIE CUT			
GUSSET				REINF.			

BOARD SPECS		5/16" R. CORNERS		GAUGE	PCS.	BOARD SPECS		5/16" R. CORNERS		GAUGE	PCS.
F.C. BOARD	11 17/32 X 10 31/32	PADDED	100	1	F.C. BOARD						
B.B. BOARD	11 17/32 X 1 9/32	PADDED	100	1	B.B. BOARD						
B.C. BOARD	11 17/32 X 11 1/32	PADDED	100	1	B.C. BOARD						
FLAP BD.	11 17/32 X 7 29/32		100	1	DIE CUT						
BOARD	11 17/32 X 27/32		100	1	DIE CUT						

DIE #	8088	METAL	RR W/B	RADIUS	3/8"
ORDER #	723743	CUSTOMER	METHODIST HOSPITAL	TEAR SEAL	.012
SHEET SIZE	8 1/2 X 11 1/2	STYLE CASE	VINYL PYRAMID EASEL	BAR SEAL	FLAT
CAP.	2"	DUE DATE	3-17-06	COMPLETED	
LOCATION		QUANTITY	80	DATE	3-8-06

*** WARNING DRAWING NOT ACTUAL SIZE ***

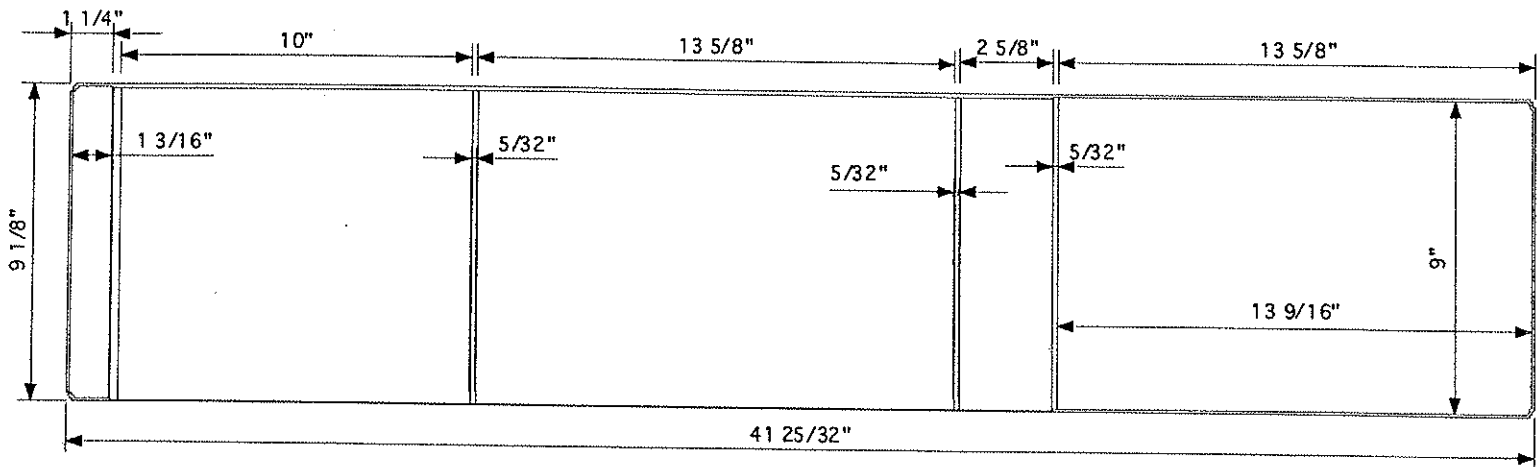

MATERIAL SPECS		GAUGE	PCS.	MATERIAL SPECS	GAUGE	PCS.
COVER MAT.	9 7/8 X 42 1/2		1	LINING MAT.	9 7/8 X 42 1/2	1
COVER MAT.				LINING MAT.		
DIE CUT				HORZ. PKT.		
COL				VERT. PKT.		
LABEL HOLDER				DIE CUT		
GUSSET				REINF.		
BOARD SPECS		GAUGE	PCS.	BOARD SPECS	GAUGE	PCS.
F.C. BOARD	8 29/32 X 13 15/32	120	1	F.C. BOARD		
B.B. BOARD	8 29/32 X 2 17/32	120	1	B.B. BOARD		
B.C. BOARD	8 29/32 X 13 17/32	120	1	B.C. BOARD		
FLAP BD.	8 29/32 X 9 29/32	120	1	DIE CUT		
BOARD	8 29/32 X 1 3/32	120	1	DIE CUT		

DIE #	8104	METAL	NONE	RADIUS	
ORDER #	726864	CUSTOMER	COMM. MARKETS	TEAR SEAL	.012
SHEET SIZE	8 1/2 X 5 1/2	STYLE CASE	VINYL DESK EASEL	BAR SEAL	178 FLAT
CAP.		DUE DATE	4-12-06	COMPLETED	
LOCATION		QUANTITY	600	DATE	3-29-06

*** WARNING DRAWING NOT ACTUAL SIZE ***

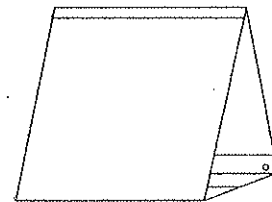
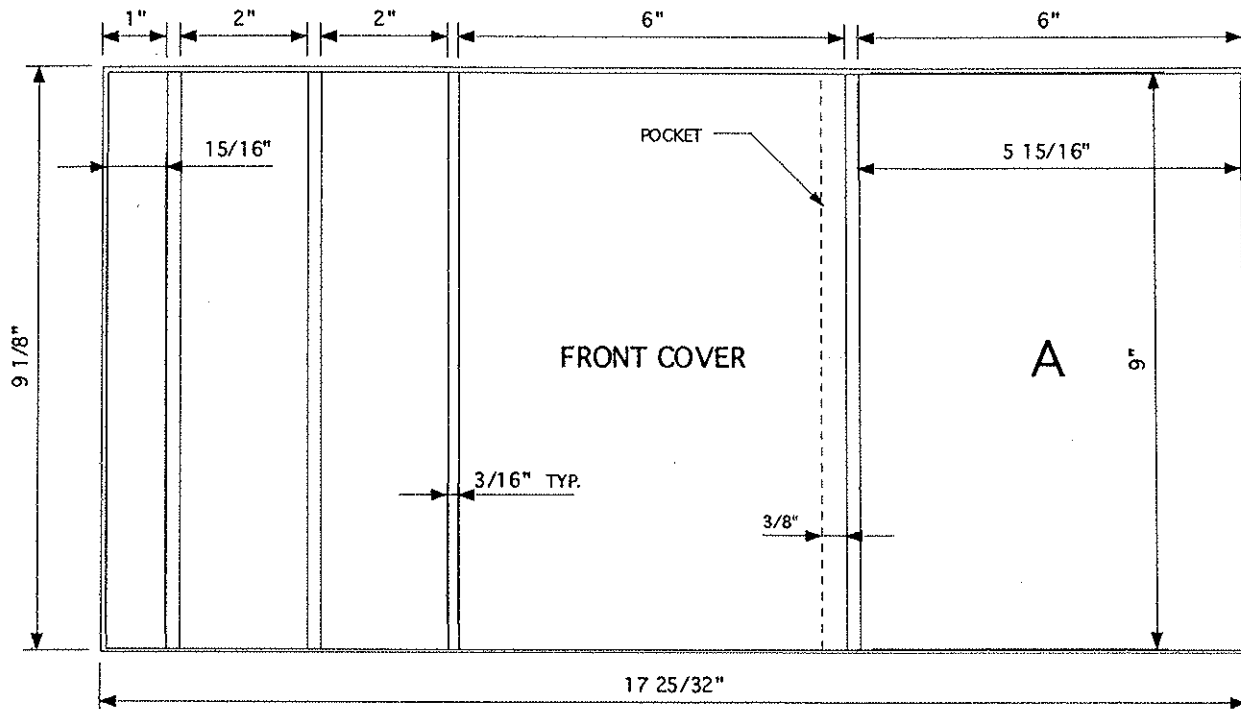

MATERIAL SPECS		GAUGE	PCS.	MATERIAL SPECS	GAUGE	PCS.
COVER MAT.	9 7/8 X 18 1/2		1	LINING MAT.	9 7/8 X 18 1/2	1
COVER MAT.				LINING MAT.		
DIE CUT				HORZ. PKT.		
COL				VERT. PKT.	9 7/8 X 5 13/16	1
LABEL HOLDER				DIE CUT		
GUSSET				REINF.		
BOARD SPECS		GAUGE	PCS.	BOARD SPECS	GAUGE	PCS.
F.C. BOARD	8 15/16 X 5 15/16	100	1	F.C. BOARD		
B.B. BOARD	8 15/16 X 5 7/8	100	1	B.B. BOARD		
B.C. BOARD				B.C. BOARD		
FLAP BD.	8 15/16 X 27/32	100	1	DIE CUT		
BOARD				DIE CUT		

DIE #	8163	METAL	RR	RADIUS	3/8"
ORDER #	741491	CUSTOMER	JR RESOURCES	TEAR SEAL	.014
SHEET SIZE	8 1/2 X 6	STYLE CASE	PYRAMID EASEL	BAR SEAL	FLAT
CAP.	1/2"	DUE DATE	7-3-06	COMPLETED	
LOCATION		QUANTITY	1	DATE	7-5-06

*** WARNING DRAWING NOT ACTUAL SIZE ***

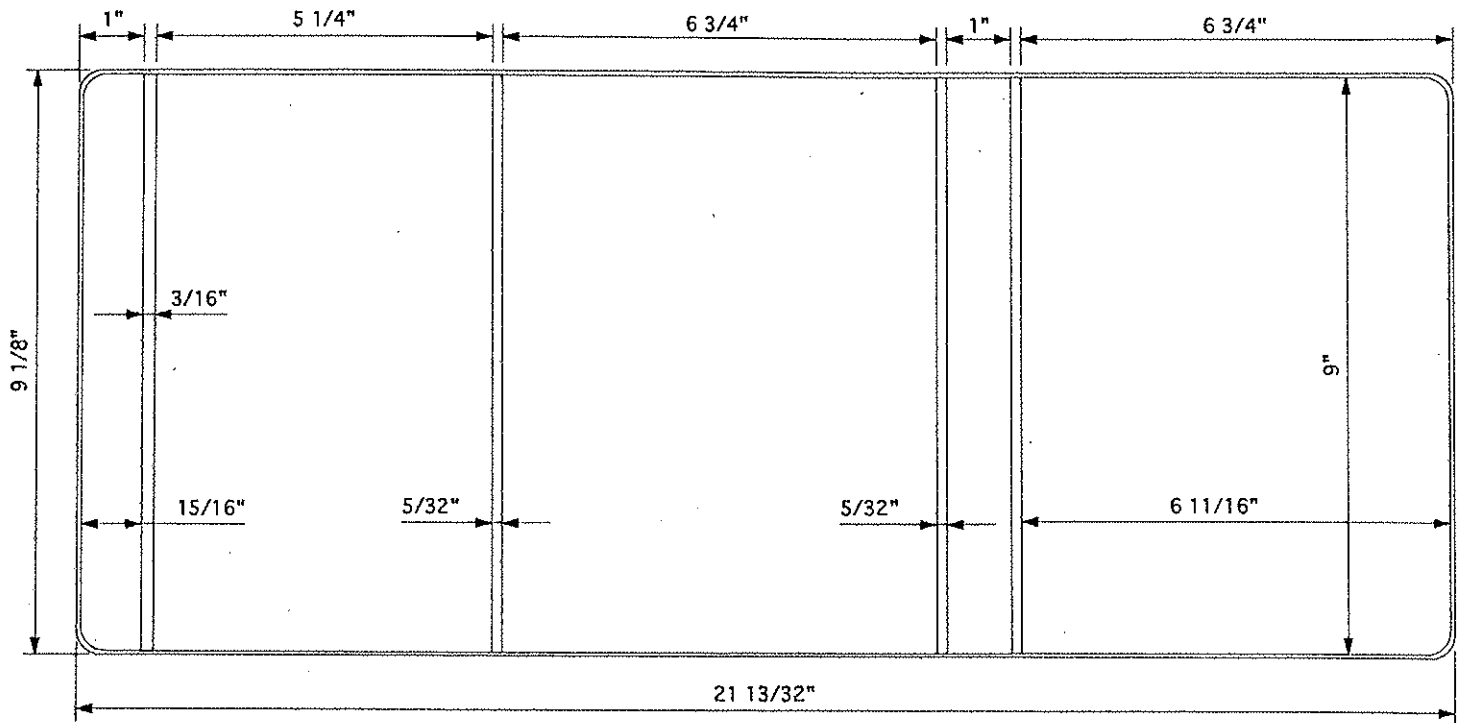

MATERIAL SPECS		GAUGE	PCS.	MATERIAL SPECS	GAUGE	PCS.
COVER MAT.	9 7/8 X 22 3/8		1	LINING MAT.	9 7/8 X 22 3/8	1
COVER MAT.				LINING MAT.		
DIE CUT				HORZ. PKT.		
COL				VERT. PKT.		
LABEL HOLDER				DIE CUT		
GUSSET				REINF.		
BOARD SPECS		GAUGE	PCS.	BOARD SPECS	GAUGE	PCS.
F.C. BOARD	8 15/16 X 6 5/8	100	1	F.C. BOARD		
B.B. BOARD	8 15/16 X 29/32	100	1	B.B. BOARD		
B.C. BOARD	8 15/16 X 6 11/16	100	1	B.C. BOARD		
FLAP BD.	8 15/16 X 27/32	100	1	DIE CUT		
BOARD	8 15/16 X 5 3/16	100	1	DIE CUT		

DIE #	8219	METAL	LOC	RADIUS	3/8"
ORDER #	757581	CUSTOMER	HUNT REAL ESTATE	TEAR SEAL	.014
SHEET SIZE	11 X 9	STYLE CASE	VINYL PYRAMID EASEL	BAR SEAL	FLAT
CAP.	3/4"	DUE DATE	10-20-06	COMPLETED	
LOCATION		QUANTITY	1	DATE	10-12-06

*** WARNING DRAWING NOT ACTUAL SIZE ***

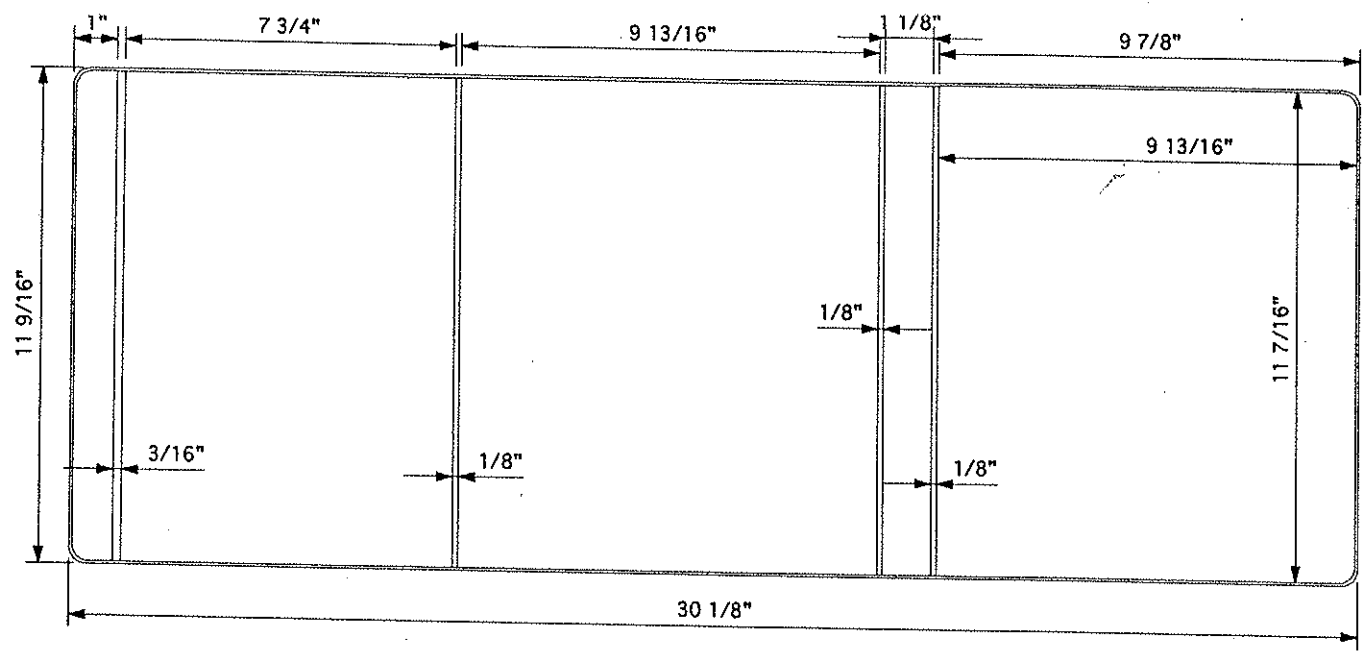

MATERIAL SPECS		GAUGE	PCS.	MATERIAL SPECS		GAUGE	PCS.
COVER MAT.	12 5/16 X 30 7/8		1	LINING MAT.	12 5/16 X 30 7/8		1
COVER MAT.				LINING MAT.			
DIE CUT				HORZ. PKT.			
COL				VERT. PKT.			
LABEL HOLDER				DIE CUT			
GUSSET				REINF.			
BOARD SPECS		5/16" R. CORNERS		BOARD SPECS		5/16" R. CORNERS	
F.C. BOARD	11 3/8 X 9 3/4	100	1	F.C. BOARD			
B.B. BOARD	11 3/8 X 1 1/32	100	1	B.B. BOARD			
B.C. BOARD	11 3/8 X 9 3/4	100	1	B.C. BOARD			
FLAP BD.	11 3/8 X 7 11/16	100	1	DIE CUT			
BOARD	11 3/8 X 27/32	100	1	DIE CUT			

DIE #	8231	METAL	RR	RADIUS	3/8"
ORDER #	759797	CUSTOMER	CURTIS 1000	TEAR SEAL	.014
SHEET SIZE	8 1/2 X 6	STYLE CASE	VINYL PYRAMID EASEL	BAR SEAL	FLAT
CAP.	2"	DUE DATE	11-10-06	COMPLETED	
LOCATION		QUANTITY	725	DATE	10-30-06

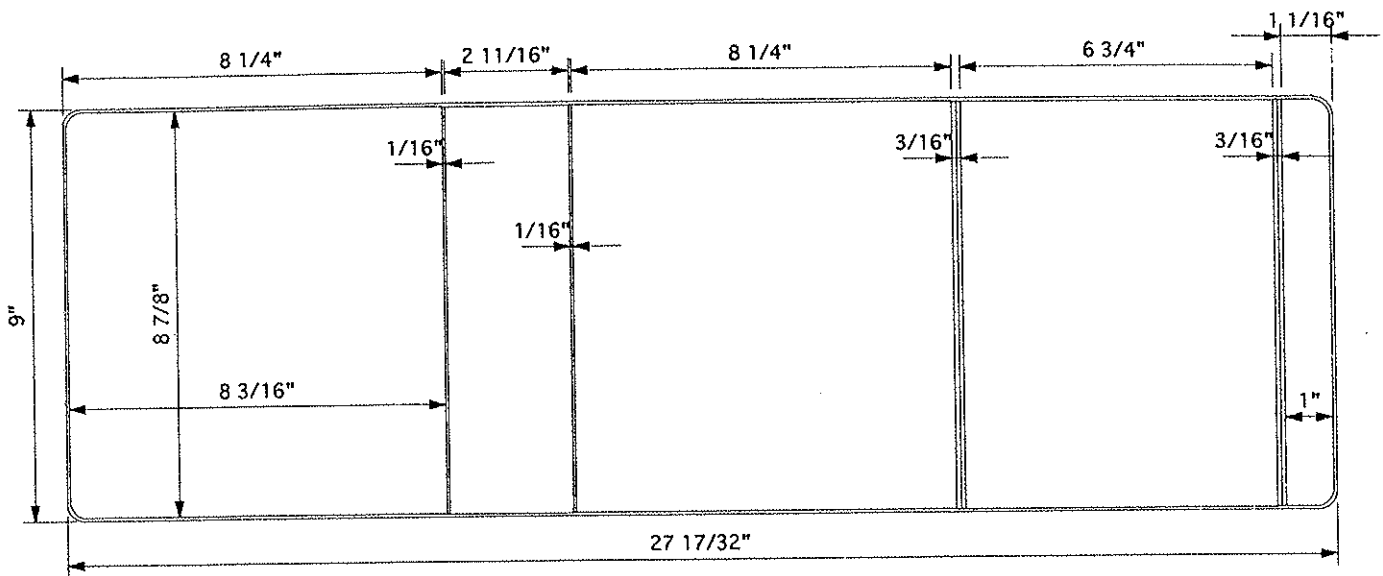

MATERIAL SPECS		GAUGE	PCS.	MATERIAL SPECS		GAUGE	PCS.
COVER MAT.	9 3/4 X 28 1/4		1	LINING MAT.	9 3/4 X 28 1/4		1
COVER MAT.				LINING MAT.			
DIE CUT				HORZ. PKT.			
COL				VERT. PKT.			
LABEL HOLDER				DIE CUT			
GUSSET				REINF.			

BOARD SPECS		GAUGE	PCS.	BOARD SPECS		GAUGE	PCS.
5/16" R. CORNERS				5/16" R. CORNERS			
F.C. BOARD	8 25/32 X 8 3/32	120	1	F.C. BOARD			
B.B. BOARD	8 25/32 X 2 19/32	120	1	B.B. BOARD			
B.C. BOARD	8 25/32 X 8 5/32	120	1	B.C. BOARD			
FLAP BD.	8 25/32 X 7/8	120	1	DIE CUT			
BOARD	8 25/32 X 6 21/32	120	1	DIE CUT			

DIE #	8548	METAL	2 RING RR	RADIUS	1/4"
ORDER #	851841	CUSTOMER	ADVANCE LOOSELEAF	TEAR SEAL	.014
SHEET SIZE	6 X 9 1/2	STYLE CASE	VINYL PYRAMID EASEL	BAR SEAL	253
CAP.	1"	DUE DATE	7-28-08	COMPLETED	
LOCATION		QUANTITY	400	DATE	7-17-08

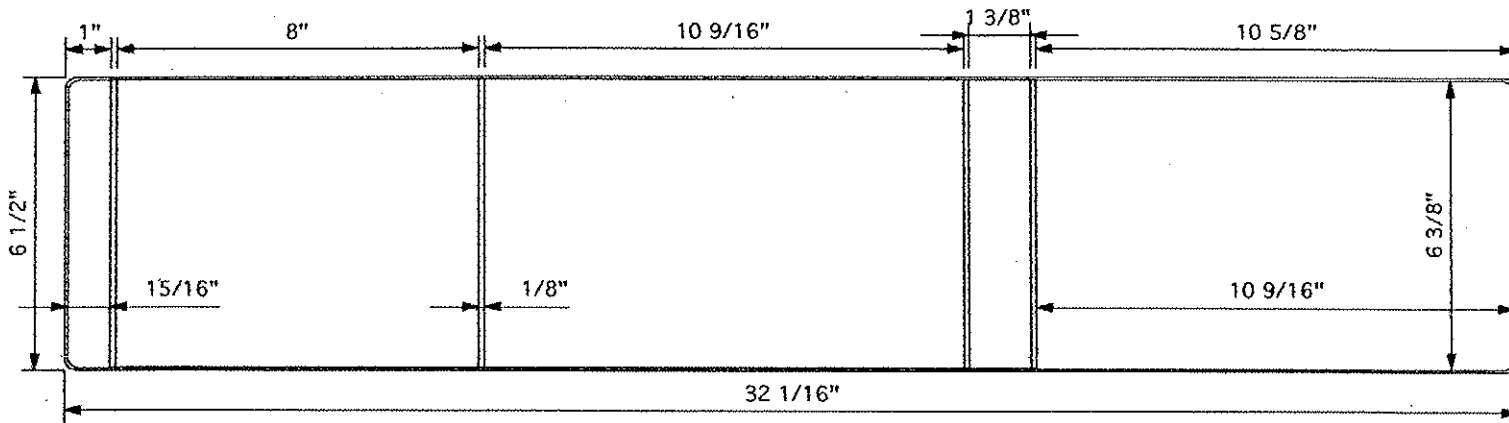

MATERIAL SPECS		GAUGE	PCS.	MATERIAL SPECS		GAUGE	PCS.
COVER MAT.	7 1/4 X 32 13/16		1	LINING MAT.	7 1/4 X 32 13/16		1
COVER MAT.				LINING MAT.			
DIE CUT				HORZ. PKT.			
COL				VERT. PKT.	7 1/4 X 5 3/8		1
LABEL HOLDER				DIE CUT			
GUSSET				REINF.			

BOARD SPECS		GAUGE	PCS.	BOARD SPECS		GAUGE	PCS.
5/16" R. CORNERS				5/16" R. CORNERS			
F.C. BOARD	6 5/16 X 10 1/2	100	1	F.C. BOARD			
B.B. BOARD	6 5/16 X 1 9/32	100	1	B.B. BOARD			
B.C. BOARD	6 5/16 X 10 1/2	100	1	B.C. BOARD			
FLAP BD.	6 5/16 X 27/32	100	1	DIE CUT			

DIE #	8604	METAL	8 1/2" LOC	RADIUS	1/4"
ORDER #	868985	CUSTOMER	CONN'S ELECTRONICS	TEAR SEAL	.014
SHEET SIZE	8 1/2 X 7	STYLE CASE	VINYL PYRAMID EASEL	BAR SEAL	253
CAP.	1"	DUE DATE	11-5-08	COMPLETED	
LOCATION		QUANTITY	50	DATE	10-23-08

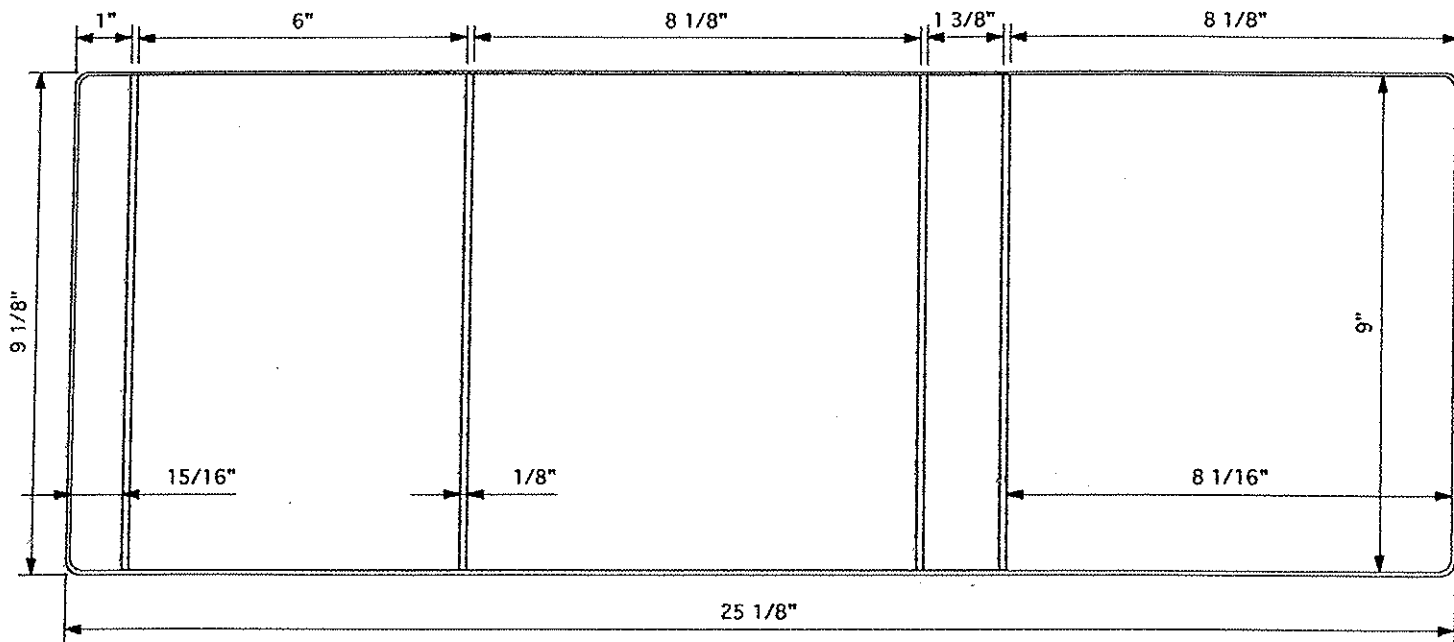

MATERIAL SPECS		GAUGE	PCS.	MATERIAL SPECS		GAUGE	PCS.
COVER MAT.	9 7/8 X 25 7/8		1	LINING MAT.	9 7/8 X 25 7/8		1
COVER MAT.				LINING MAT.			
DIE CUT				HORZ. PKT.			
COL				VERT. PKT.			
LABEL HOLDER				DIE CUT			
GUSSET				REINF.			
BOARD SPECS		GAUGE	PCS.	BOARD SPECS		GAUGE	PCS.
	5/16" R. CORNERS				5/16" R. CORNERS		
F.C. BOARD	8 15/16 X 8	100	1	F.C. BOARD			
B.B. BOARD	8 15/16 X 1 9/32	100	1	B.B. BOARD			
B.C. BOARD	8 15/16 X 8 1/16	100	1	B.C. BOARD			
FLAP BD.	8 15/16 X 27/32	100	1	DIE CUT			
BOARD	8 15/16 X 5 29/32	100	1	DIE CUT			