

Product Code

Style Case for Nylon Reinforcement

Sheet Size 11 X 9 Cap. 3 1/2 Die No. 2695 Order No. 15969-9 Plate

Customer	Alco Food Service
Material	
Total Vinyl	.030
Quantity	200
Date	9-3-51
Type Corners	R1
Radius	1/4
Completed	

Alco Food Service

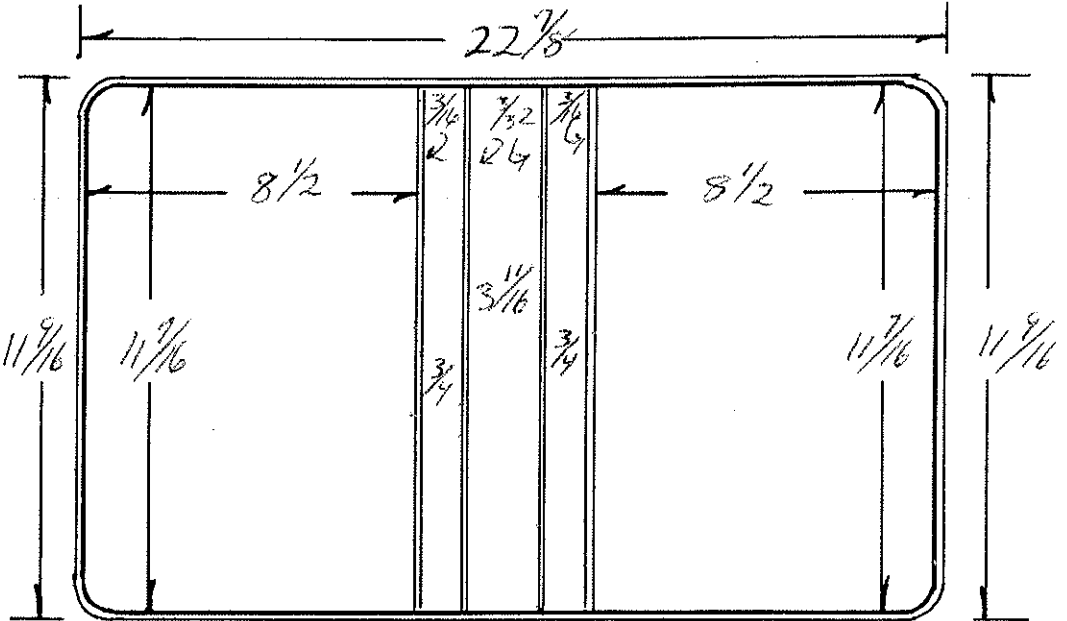

	Gauge	Thick
ear Seal	1016	3/32
ar Seal	107	4/32
ar Seal	175	3/16

	No. of Feet
ear Seal	
ar Seal	
ar Seal	

Mill B.B Bars
Down .006
for Nylon
Reinforcement

Code	Ga.	Pcs	Cutting Specs		Code	Ga.	Pcs	Cutting Specs	
			Size	Out				Size	Out
Over Mat.		1	12 3/16 X	23 5/8	Lining Mat.		1	12 3/16 X	23 5/8
Over Mat			X		Lining Mat.			X	
Art. Pckt.			X		Horz. Pckt.			X	
Art. Pckt.			X		Horz. Pckt.			X	
Pocket			X		Pocket			X	
Label Holder			X		Card Holder			X	
Material			X		Material			X	
Material			X		Material			X	
Material			X		Material			X	
B.C. Board		120	11 5/16 X	8 3/8	B.C. Board		120	11 5/16 X	8 3/8
B.C. Board			X		B.B. Board			11 5/16 X	3 9/16
Center Board			X		Board			11 5/16 X	5/8
Board			X		Strip			X	
Over Pad			X		Strip			X	
					B.B. Pad			X	
					Nylon			11 X	6 1/4

Product Code

Style Case Post Binder Fixed

Sheet Size 11 X 9

Cap. 4

Die No. 3633

Order No. 58448

Plate

Customer

Ebsco Media - Ad spec

Material	
Total Vinyl	<u>.030</u>
Quantity	<u>500</u>
Date	<u>10-6-86</u>
Type Corners	<u>Rd</u>
Radius	<u>1/4</u>
Completed	

	Gauge	Thick
ear Seal	<u>016</u>	<u>3/32</u>
ar Seal	<u>178</u>	<u>3/16</u>
ar Seal		

	No. of Feet
ear Seal	
ar Seal	
ar Seal	

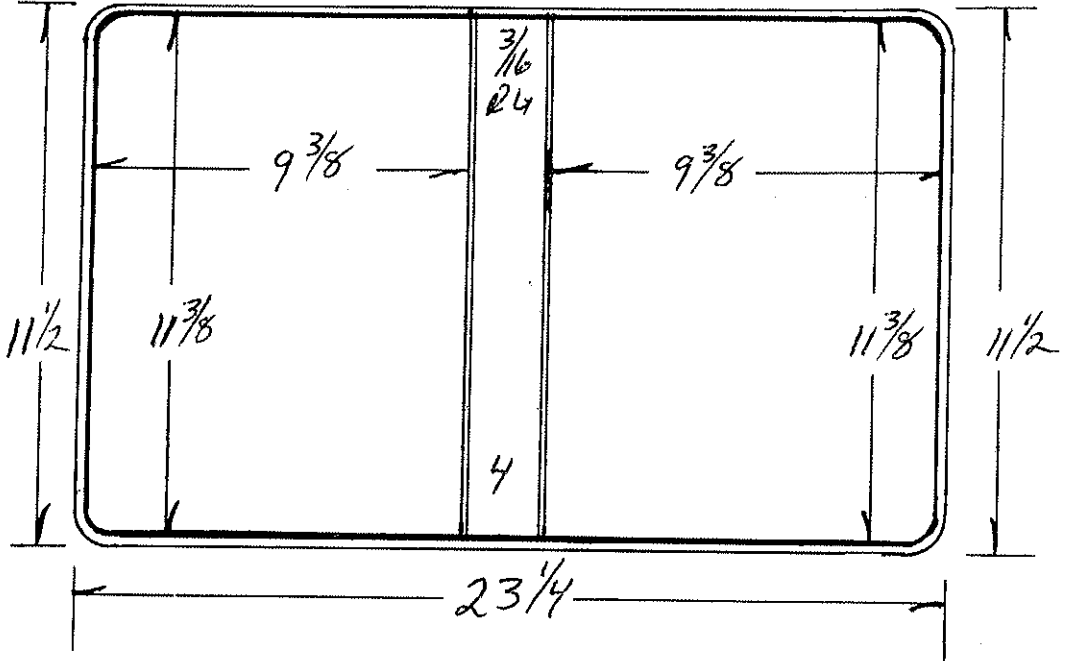

Code	Ga.	PCS	Cutting Specs		Code	Ga.	Pcs.	Cutting Specs	
			Size	Out				Size	Out
ver Mat.		<u>12 1/8 X 24</u>		<u>1</u>	Lining Mat.		<u>12 1/8 X 24</u>		<u>1</u>
ver Mat.		X			Lining Mat.		X		
rt. Pckt.		X			Horz. Pckt.		X		
rt. Pckt.		X			Horz. Pckt.		X		
ocket		X			Pocket		X		
el Holder		X			Card Holder		X		
terial		X			Material		X		
terial		X			Material		X		
terial		X			Material		X		
C. Board		<u>11 1/4 X 9 1/4</u>		<u>1</u>	B.C. Board		<u>11 1/4 X 9 1/4</u>		<u>1</u>
C. Board		X			B.B. Board		<u>11 1/4 X 3 7/8</u>		<u>1</u>
ter Board		X			Board		X		
ard		X			Strip		<u>2 X 12</u>		<u>2</u>
ver Pad		X			Strip		X		
					B.B. Pad		X		

Product Code

Style Case *WITH EVERLASTING*
Carlin's Rest

Sheet Size 11 X 9

Cap. 5 1/8 Die No. 3708

Order No. 954070

Plate

Tool & Equipment Warehouse

Customer	
Material	
Total Vinyl	<u>1030</u>
Quantity	<u>100</u>
Date	<u>1-12-87</u>
Type Corners	<u>Rd</u>
Radius	<u>1/4</u>
Completed	

	Gauge	Thick
Bar Seal	<u>.016</u>	<u>3/32</u>
Bar Seal	<u>89b's</u>	<u>4MM</u>
Bar Seal	<u>89b's</u>	<u>3MM</u>

	No. of Feet
Bar Seal	
Bar Seal	
Bar Seal	

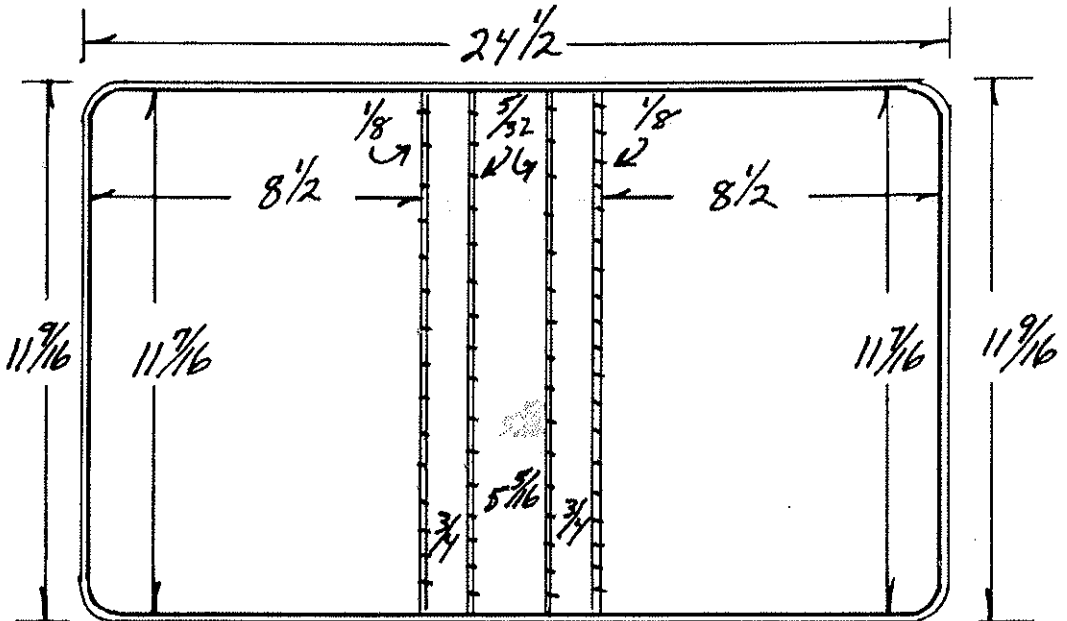

Code	Ga.	PCS	Cutting Specs		Code	Ga.	Pcs.	Cutting Specs	
			Size	Out				Size	Out
Cover Mat.			<u>12 3/16 X 25 1/4</u>		Lining Mat.			<u>12 3/16 X 25 1/4</u>	
Cover Mat			X		Lining Mat.			X	
vert. Pckt.			X		Horz. Pckt.			X	
vert. Rckt.			X		Horz. Pckt.			X	
Pocket			X		Pocket			X	
Label Holder			X		Card Holder			X	
Material			X		Material			X	
Material			X		Material			X	
Material			X		Material			X	
B.C. Board			<u>11 3/8 X 8 7/16</u>	<u>100 1</u>	B.C. Board			<u>11 3/8 X 8 7/16</u>	<u>100 1</u>
Board			<u>11 1/32 X 8 13/32</u>	<u>120 2</u>	B.B. Board			<u>11 3/8 X 5 1/4</u>	<u>100 1</u>
Center Board			<u>11 1/32 X 5 7/32</u>	<u>120 1</u>	Board			<u>11 3/8 X 1 1/16</u>	<u>100 2</u>
Board			<u>11 1/32 X 2 1/32</u>	<u>120 2</u>	Strip			X	
Cover Pad			X		Strip			X	
					B.B. Pad			X	

Product Code

old 1302

Style Case Special Quinn - 4

Sheet Size 11 X 9

Cap. 3 3/4 MAPIE No. 4019

Order No. 958722 Plate

official products

Customer	
Material	
Total Vinyl	.032
Quantity	200
Date	5-3-88
Type Corners	RD
Radius	1/4
Completed	

	Gauge	Thick
ear Seal	.016	3/32
er Seal	102	3/32
er Seal		

	No. of Feet
ear Seal	
er Seal	
er Seal	

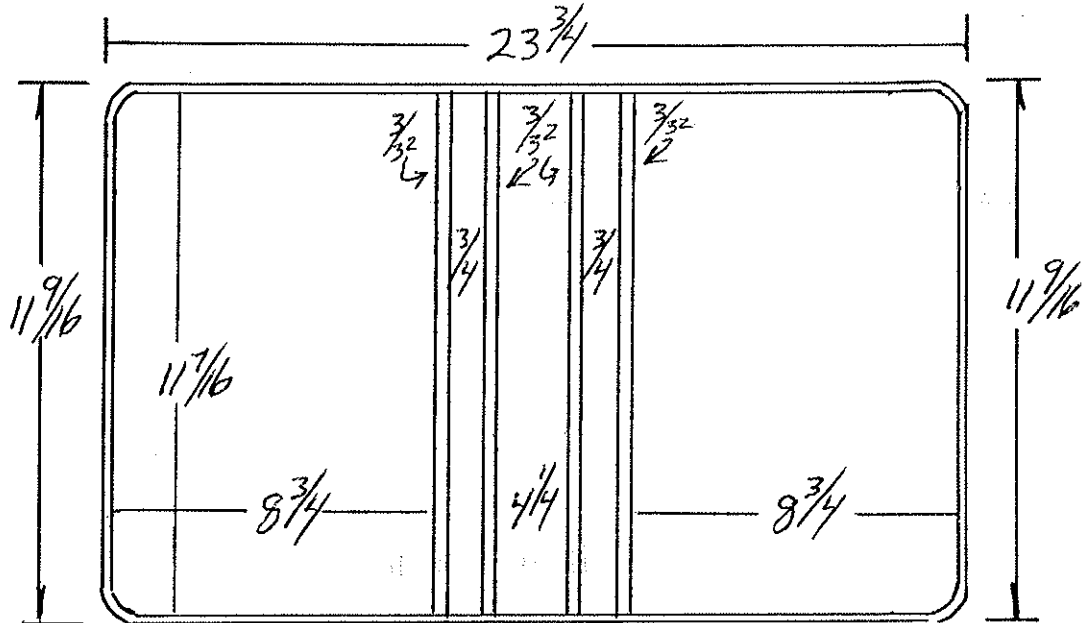

Code	Ga.	Pcs	Cutting Specs		Code	Ga.	Pcs	Cutting Specs	
			Size	Out				Size	Out
Cover Mat.		1	12 3/16 X	24 1/2	Lining Mat.		1	12 3/16 X	24 1/2
Cover Mat			X		Lining Mat.			X	
Front Pckt.			X		Horz. Pckt.		1	5 3/8 X	24 3/8
Front Pckt.			X		Horz. Pckt.			X	
Pocket			X		Pocket			X	
Label Holder			X		Card Holder			X	
Material			X		Material			X	
Material			X		Material			X	
Material			X		Material			X	
C. Board		120	11 1/32 X	8 2/32	B.C. Board		120	11 1/32 X	8 2/32
C. Board	FC	100	11 3/8 X	8 1/16	B.B. Board		120	11 1/32 X	4 5/32
Inter Board	BC	100	11 3/8 X	8 1/16	Board		120	11 1/32 X	2 1/32
Card	BB	120	11 1/32 X	4 5/32	Strip			X	
Cover Pad	Strip	120	11 1/32 X	2 1/32	Strip		100	11 3/8 X	2 1/32
					B.B. Pad			X	

Specs 57

OW OR 140 QV

Product Code

Style Case QUA VIN

Sheet Size 11 X 9

Cap. 2"

Die No. 4149

Order No. STOCK

Plate

Customer STOCK
 Metal
 Total Vinyl
 Quantity
 Plate
 Type Corners
 Radius
 Completed

	Gauge	Thick
ear Seal		
ar Seal		
ar Seal		

	No. of Feet
ear Seal	
ar Seal	
ar Seal	

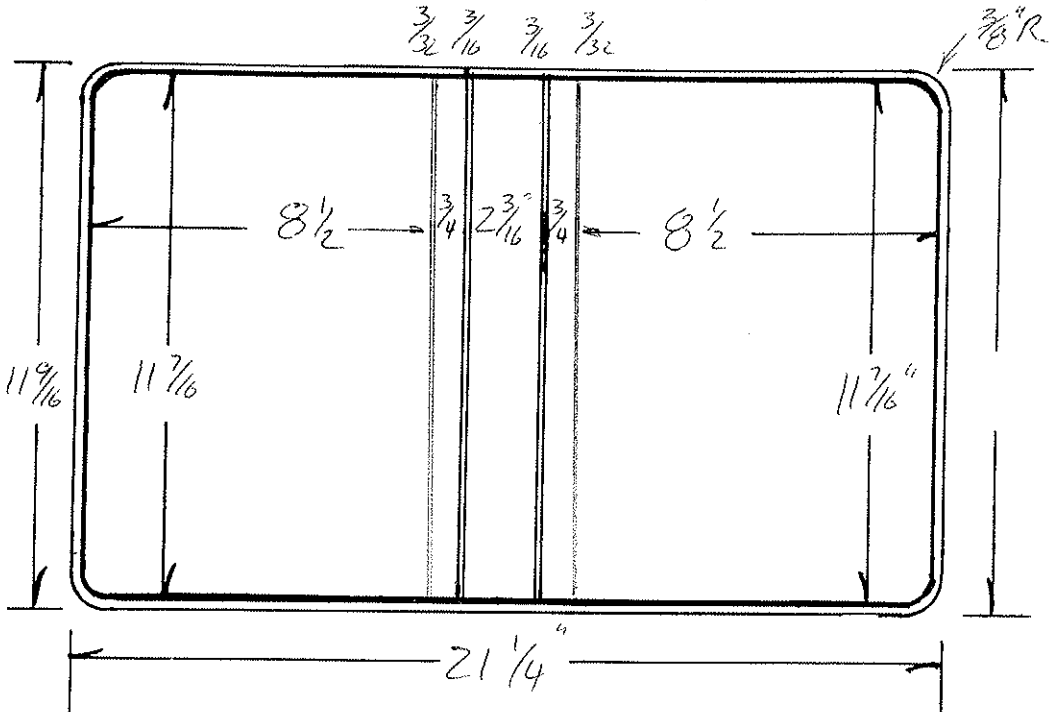

Code	Ga.	# PCS	Cutting Specs		Code	Ga.	# Pcs.	Cutting Specs	
			Size	Out #				Size	Out #
over Mat.		1	12 1/4 X 22 1/4		Lining Mat.		1	12 1/4 X 22 1/4	
over Mat			X		Lining Mat.			X	
rt. Pckt.			X		Horz. Pckt.			X	
rt. Rckt.			X		Horz. Pckt.			X	
ocket			X		Pocket			X	
el Holder			X		Card Holder			X	
aterial			X		Material			X	
aterial			X		Material			X	
aterial			X		Material			X	
C. Board		1	11 1/32 X 8 13/32	120	B.C. Board	FC	1	11 3/8 X 8 7/16	100
C. Board		1	11 1/32 X 8 13/32	100	B.B. Board	BC	1	11 3/8 X 8 7/16	100
ter Board	BB	1	11 1/32 X 2 3/32	120	Board	BB	1	11 3/8 X 2 1/8	100
ard	Strip	2	11 1/32 X 2 1/32	120	Strip	Strip	2	11 3/8 X 2 1/32	100
ver Pad			X		Strip			X	
					B.B. Pad			X	
C Board			11 3/8 X 8 7/16	100					
C Board			11 3/8 X 8 7/16	100					

2-Up Die #5903

Product Code

Style Case

VPB

Sheet Size

11 x 9

Cap.

1

Die No. 4193

Order No. 962273

Plate

Customer NORTHERN TELECOM

Metal
Total Vinyl
Quantity 2,000
Date 4-26-89
Type Corners RND
Radius 3/8"
Completed

	Gauge	Thick
Tear Seal	.016	3/32
Bar Seal	5	3/32
Bar Seal		

	No. of Feet
Tear Seal	
Bar Seal	
Bar Seal	

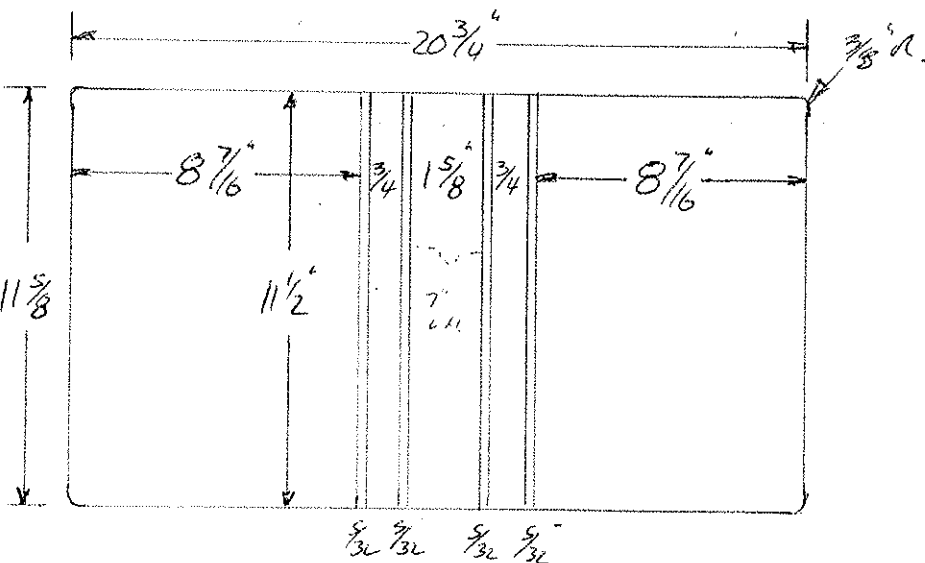

Code		Ga.		PCS		Cutting Specs		Code		Ga.		PCS		Cutting Specs	
						Size	Out							Size	Out
Cover Mat.		12 1/4	X	21 1/2	15	1		Lining Mat.		12 1/4	X	21 1/2	15	1	
Cover Mat			X					Lining Mat.			X				
Vert. Pckt.			X					Horz. Pckt.			X				
Vert. Pckt.			X					Horz. Pckt.			X				
Pocket		Cutting Die # 4193-B						Pocket		Flat Cut LH. per Billy Wagon					
Label Holder		8 3/4 X 1 3/4						Card Holder		6 3/4 X 2					
Material								Material			X				
Material			X					Material			X				
Material			X					Material			X				
F.C. Board		11 13/32	X	8 1/2	120	1		B.C. Board			X				
B.C. Board		11 13/32	X	8 1/2	120	1		B.B. Board		11 13/32	X	2 1/32	120	(2)	
Center Board		11 13/32	X	1 1/32		1		Board		BB	11 3/8	X	2 1/32	100	
Board	FC	11 7/16	X	8 3/8	100	pt.		Strip			X				
Cover Pad	BC	11 7/16	X	8 3/8	100	pt.		Strip			X				
	Center	11 13/32	X	1 17/32	120	pt.		B.B. Pad			X				

Product Code

2up Die # 7025
Style Case VINYL POST BINDER

Sheet Size 11 x 9 Cap. 2 Die No. 4195 Order No. 962270 Plate

Customer NORTHERN TELECOM

Metal
Total Vinyl
Quantity 7,000
Date 4-26-89
Type Corners RND
Radius 3/8"
Completed

	Gauge	Thick
Tear Seal	016	3/8
Bar Seal		5/32
Bar Seal		

	No. of Feet
Tear Seal	
Bar Seal	
Bar Seal	

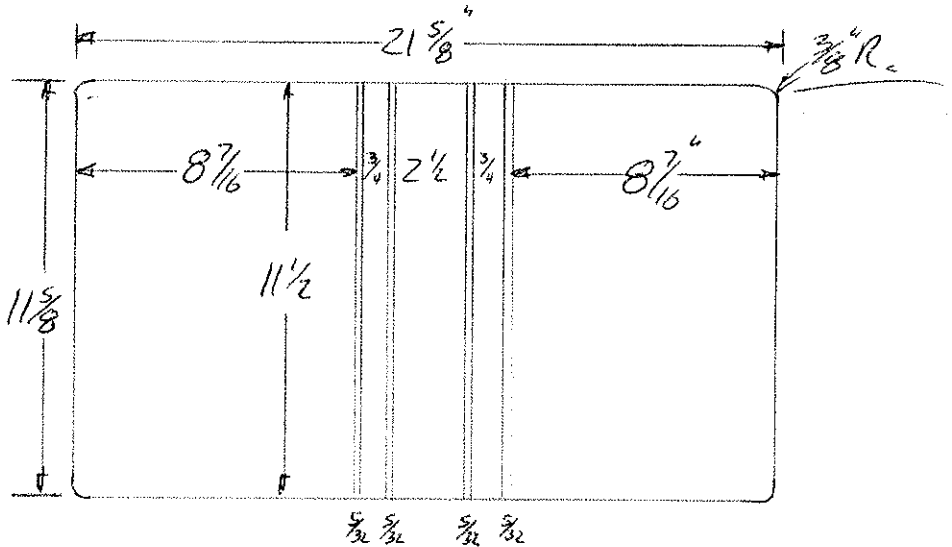

Code		Cutting Specs				Code		Cutting Specs			
		Ga.	# PCS	Size	Out			Ga.	# Pcs.	Size	Out
Cover Mat.				12 1/4 x 22 3/8		Lining Mat.				12 1/4 x 22 3/8	
Cover Mat				X		Lining Mat.				X	
Vert. Pckt.				X		Horz. Pckt.				X	
Vert. Pckt.				X		Horz. Pckt.				X	
Pocket						Pocket					
Label Holder	Old			Cutting Die # 4195 B		Card Holder				Flat Cut x L.N. (per Billy Casper)	
Material				X		Material				6 3/4 x 2 7/8	
Material				X		Material				X	
Material				X		Material				X	
F.C. Board				11 13/32 x 8 1/32	100	B.C. Board				X	
B.C. Board				11 13/32 x 8 1/32	100	B.B. Board				11 13/32 x 2 1/32	100 (2)
Center Board				11 13/32 x 2 13/32	100	Board	BD			11 7/16 x 2 1/32	100 (1)
Board	FC			11 7/16 x 8 3/8	100	Strip				X	
Cover Pad	BC			11 7/16 x 8 3/8	100	Strip				X	
	Center			11 7/16 x 2 7/16	100	B.B. Pad				X	

Product Code

Style Case VINYL POST BINDER

Sheet Size 11 x 9 Cap. 3

Die No. 4197

Order No. 962271

Plate

Customer NORTHAN TELCOM

Metal
Total Vinyl
Quantity <u>8,000</u>
Date <u>4-26-89</u>
Type Corners <u>RM</u>
Radius <u>3/16"</u>
Completed

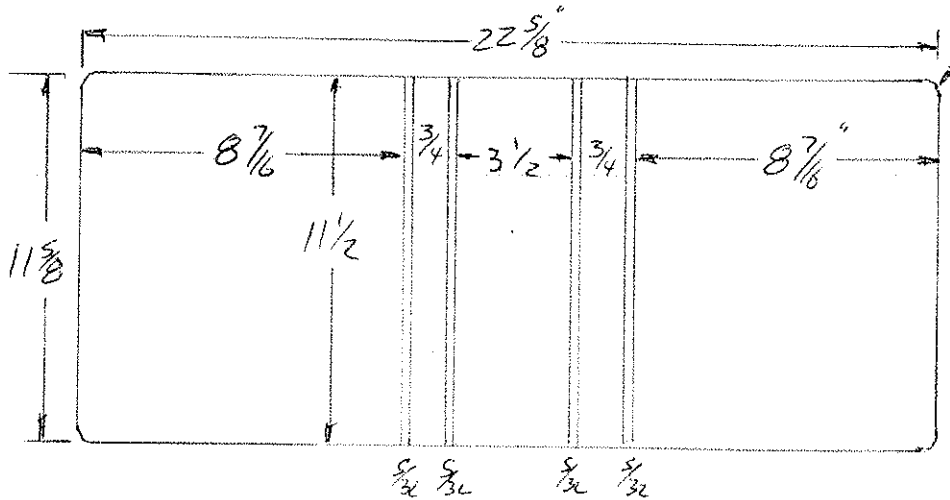

	Gauge	Thick
Tear Seal	<u>016</u>	<u>3/32</u>
Bar Seal		<u>3/32</u>
Bar Seal		

	No. of Feet
Tear Seal	
Bar Seal	
Bar Seal	

Code	Ga.	# PCS	Cutting Specs		Code	Ga.	# Pcs.	Cutting Specs	
			Size	# Out				Size	# Out
Cover Mat.		<u>12 1/4 x 23 3/8</u>	<u>15</u>	<u>1</u>	Lining Mat.		<u>12 1/4 x 23 3/8</u>	<u>15</u>	<u>1</u>
Cover Mat.		X			Lining Mat.		X		
Vert. Pckt.		X			Horz. Pckt.		X		
Vert. Pckt.		X			Horz. Pckt.		X		
Pocket		<u>Flat Cut Lid. (per Billy Wayne)</u>			Pocket		X		
Label Holder		<u>6 3/4 x 3 7/8</u>	<u>8</u>	<u>1</u>	Card Holder		X		
Material		X			Material		X		
Material		X			Material		X		
Material		X			Material		X		
F.C. Board		<u>11 3/32 x 8 1/32</u>	<u>120</u>	<u>1</u>	B.C. Board		X		
B.C. Board		<u>11 3/32 x 8 1/32</u>	<u>120</u>	<u>1</u>	B.B. Board	<u>11 7/16 x 3 1/32</u>	<u>100</u>	<u>2</u>	
Center Board		<u>11 3/32 x 3 1/32</u>	<u>120</u>	<u>1</u>	Board	<u>BB 11 3/32 x 3 1/32</u>	<u>120</u>		<u>pt.</u>
Board	<u>FC</u>	<u>11 7/16 x 8 3/8</u>	<u>100</u>	<u>pt.</u>	Strip		X		
Cover Pad	<u>BC</u>	<u>11 7/16 x 8 3/8</u>	<u>100</u>	<u>pt.</u>	Strip		X		
	<u>Center</u>	<u>11 7/16 x 3 7/16</u>	<u>100</u>	<u>pt.</u>	B.B. Pad		X		

010# 140QV

Product Code

Style Case QUA-CAN-VIN

Sheet Size 11 x 9

Cap. 3/8" MAX. Die No. 4257

Order No. 963311

Plate 3

Customer	HARRIS COMPUTER SYSTEMS
Material	
Total Vinyl	
Quantity	50
Date	8-10-89
Type Corners	RND
Radius	3/8"
Completed	

	Gauge	Thick
ear Seal	.016"	3/32
ar Seal	# 178	3/16
ar Seal	# 102	1/16

	No. of Feet
ear Seal	
ar Seal	
ar Seal	

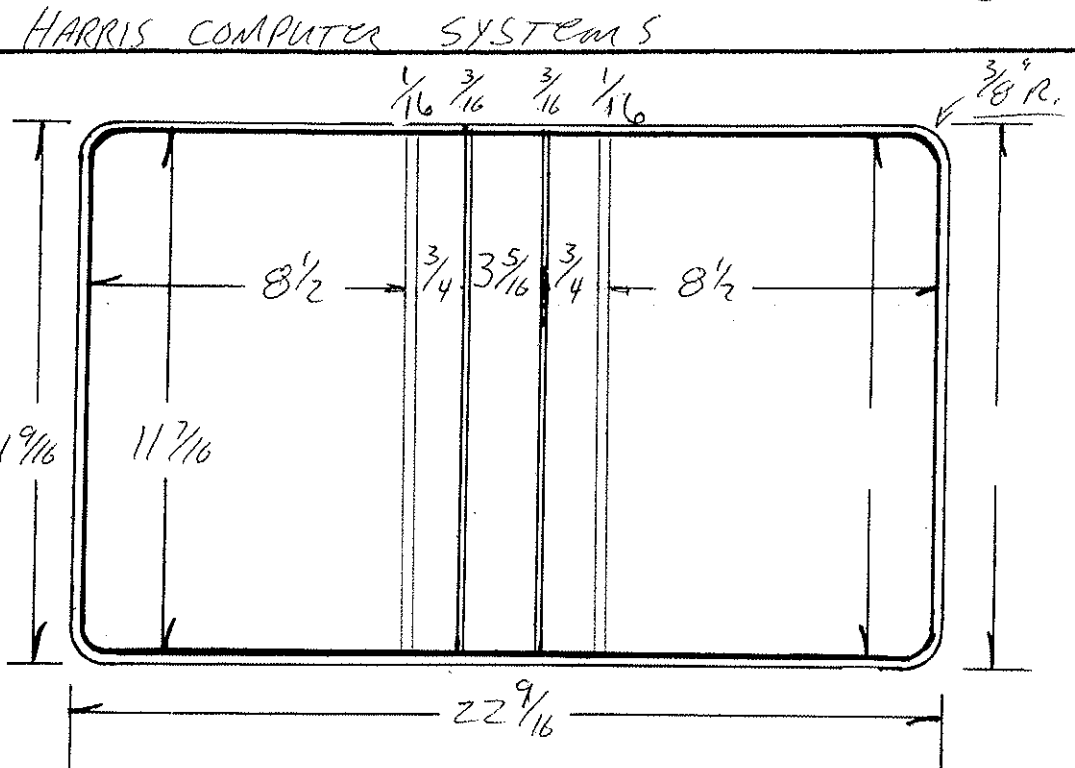

Specs 4

Code	Ga.	# Pcs	Cutting Specs		Code	Ga.	# Pcs	Cutting Specs	
			Size	Out				Size	Out
Over Mat.		15	12 1/4 X	23 3/8	Lining Mat.		15	1	
Over Mat.			X		Lining Mat.			X	
rt. Pckt.			X		Horz. Pckt.			X	
rt. Pckt.			X		Horz. Pckt.			X	
Pocket			X		Pocket			X	
Label Holder			X		Card Holder			X	
Material			X		Material	C.O.L.	8	1	11 1/16 X 4 3/8
Material			X		Material	B. Body		X	
Material			X		Material			X	
C. Board		100	11 1/32 X	8 1/32	B.C. Board			X	
C. Board		100	11 1/32 X	8 1/32	B.B. Board		100	2	11 3/8 X 2 1/32
Inter Board		100	11 1/32 X	3 7/32	Board			X	
Card	FC	100	11 3/8 X	8 7/16	Strip		100		11 1/32 X 2 1/32
Over Pad	BC	100	11 3/8 X	8 7/16	Strip			X	
	BB	100	11 3/8 X	3 7/32	B.B. Pad			X	
	Strip	100	11 3/8 X	2 1/32					

Product Code

OLD # 140 QV.

Style Case QA CAN VIN

Sheet Size 11 X 9

Cap. 1 1/2 Die No. 4291

Order No. 963736

Plate

Customer

THE TOOL CRIB INC.

Metal
Total Vinyl
Quantity 500
Date 10-3-89
Type Corners
Radius 3/8
Completed 10-3-89 KBT

	Gauge	Thick
Tear Seal	.014	1/16
Bar Seal	#178	3/16
Bar Seal	#253	1/8

	No. of Feet
Tear Seal	
Bar Seal	
Bar Seal	

SIZES BV - B.P. ✓
CHECK BY - Sm

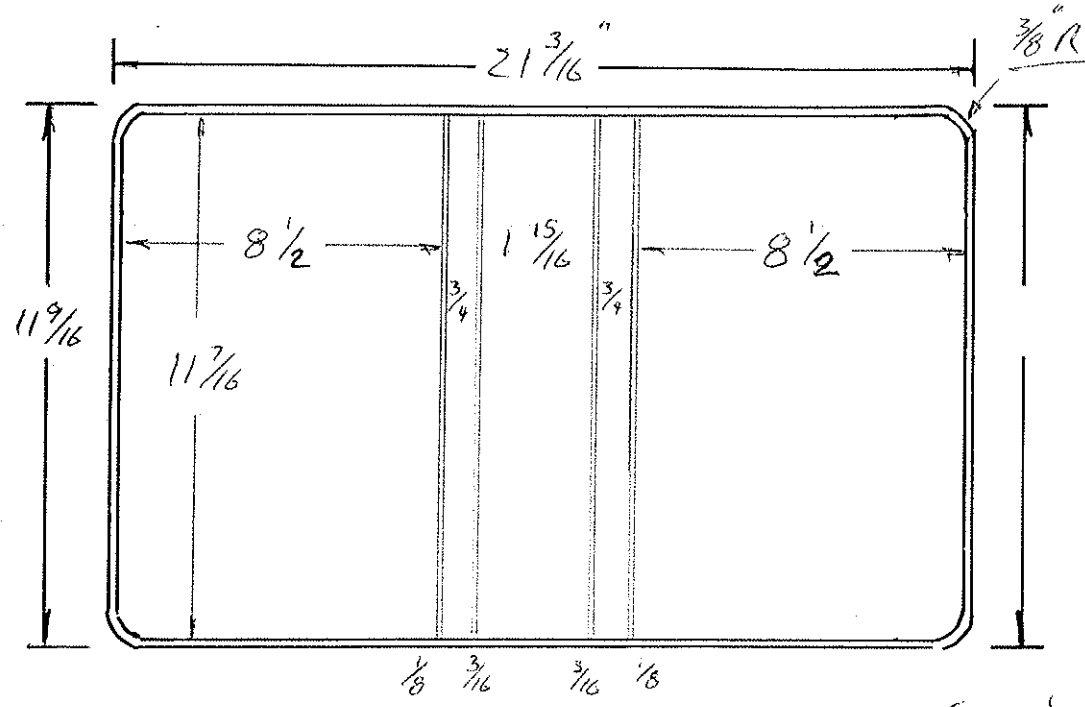

Code		Cutting Specs		Code		Cutting Specs			
		Ga.	# PCS	Size	Out	Ga.	# PCS	Size	Out
Cover Mat.	12 1/4 X 22	15	1			Lining Mat.	12 1/4 X 22	15	1
Cover Mat.	X					Lining Mat.	X		
Vert. Pckt.	X					Horz. Pckt.	X		
Vert. Pckt.	X					Horz. Pckt.	5 3/8 X 9		1
Pocket	X					Pocket	X		
Label Holder	X					Card Holder	X		
Material	X					Material	X		
Material	X					Material	X		
Material	X					Material	X		
F.C. Board	11 1/32 X 8 13/32	120	1			B.C. Board	X		
B.C. Board	11 1/32 X 8 13/32	120	1			B.B. Board	11 3/8 X 17 1/8	100	1
Center Board	FC 11 3/8 X 8 7/16	109	1			Board B.B. Strip	11 3/8 X 2 1/32	100	Z
Board	BC 11 3/8 X 8 7/16	109	1			Strip	X		
Cover Pad	BB 11 1/32 X 12 1/32	120	1			Strip	X		
	strip 11 1/32 X 1 2/32	129	2			B.B. Pad	X		

OLO# 140 QV

Product Code

Style Case QA CAN VIN

Sheet Size 11 X 9

Cap. 3 3/4 Die No. 4299

Order No. 963842

Plate

Customer

EXOTIC RUBBER & PLASTICS

Metal
Total Vinyl
Quantity
Date
Type Corners
Radius
Completed 10-16-89 RBT

	Gauge	Thick
Tear Seal	.014	1/16
Bar Seal	1/8	253
Bar Seal	3/32	254

	No. of Feet
Tear Seal	
Bar Seal	
Bar Seal	

10-18-89

BY: B.P. ✓

CHECK BY:

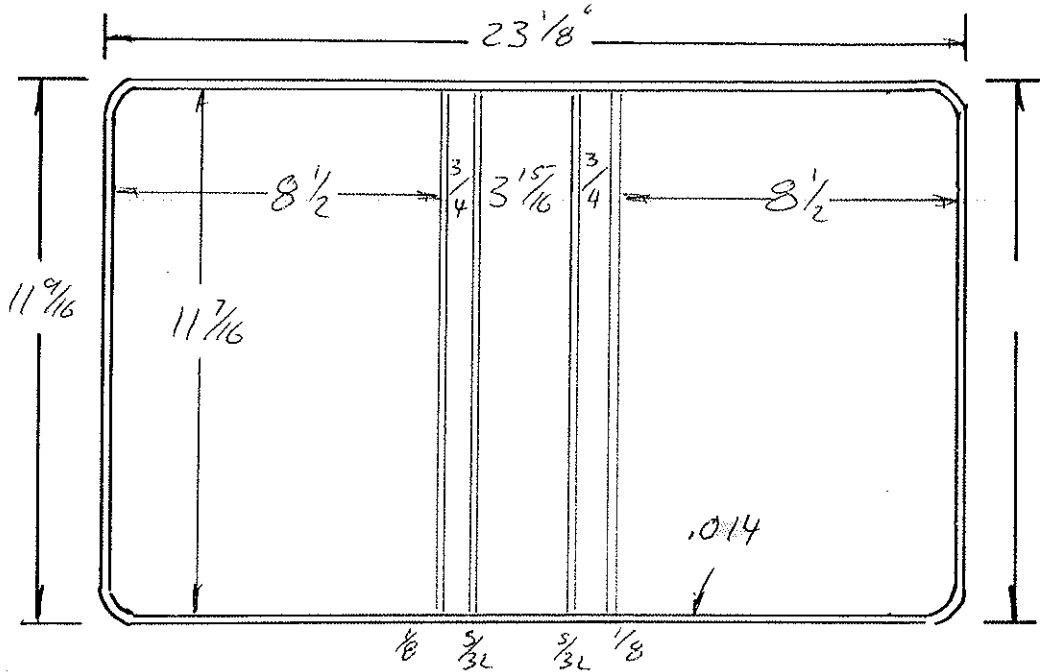

Code		Cutting Specs.		Code		Cutting Specs.			
		Ga.	PCS	Size	Out	Ga.	PCS	Size	Out
Cover Mat.	12 1/4 X 24	15	1			Lining Mat.	12 1/4 X 24	15	1
Cover Mat.	X					Lining Mat.	X		
Vert. Pckt.	X					Horz. Pckt.	X		
Vert. Rckt.	X					Horz. Pckt.	X		
Pocket	X					Pocket	X		
Label Holder	X					Card Holder	X		
Material	X					Material	X		
Material	X					Material	X		
Material	X					Material	X		
F.C. Board	11 1/32 X 8 13/32	120	1			B.C. Board	X		
B.C. Board	11 1/32 X 8 13/32	120	1			B.B. Board	11 1/32 X 9 1/32	120	2
Center Board	11 1/32 X 3 27/32	120	1			Board	X		
Board	FC 11 3/8 X 8 7/16	100	1			Strip	BB 11 3/8 X 3 7/8	100	1
Cover Pad	BC 11 3/8 X 8 7/16	100	1			Strip	Strip 11 3/8 X 2 1/32	100	2
						B.B. Pad	X		

OLD # 3272

Product Code

Style Case *SPECIAL POST VINDER*

ACTUAL Sheet Size $7\frac{7}{8}$ x $13\frac{1}{2}$

Cap. $1\frac{7}{16}$

Die No. 4304

Order No. 96340-1-2-4 Plate

RESPONSE ADVERTISING & MARKETING GROUP

Customer
etal
otal Vinyl
Quantity 500
ate 10-18-69
ype Corners
adius $\frac{1}{8}$ "
ompleted 10-23-69 RET

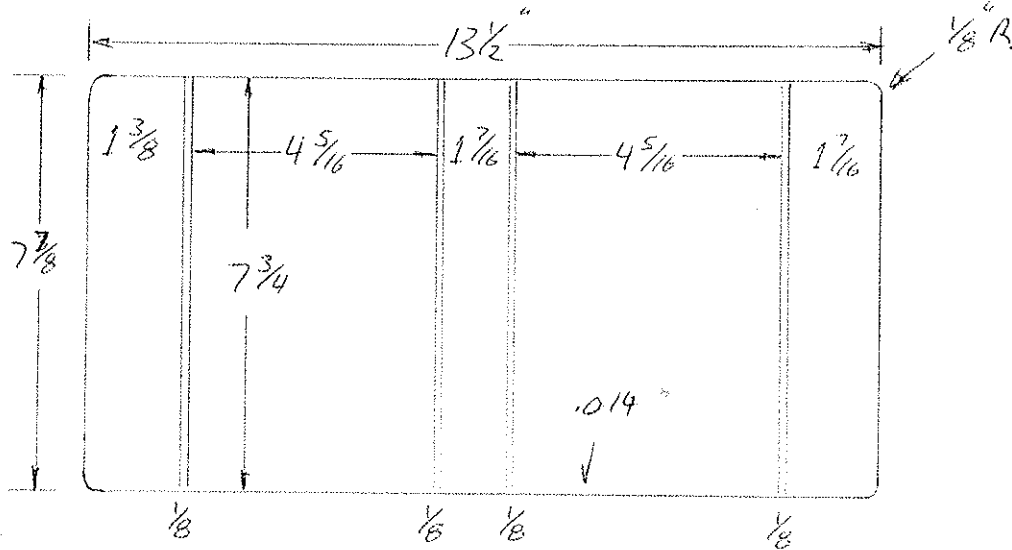

	Gauge	Thick
ear Seal	.014	$\frac{1}{16}$ "
ar Seal	#253	$\frac{1}{8}$ "
ar Seal		

	No. of Feet
ear Seal	
ar Seal	
ar Seal	

10-24

SIZE BY: B.P.

HECK BY: *(Signature)*

Code		Ga. # PCS		Cutting Specs		Code		Ga. # Pcs.		Cutting Specs	
				Size	Out					Size	Out
ver Mat.	$8\frac{5}{8}$ x $14\frac{1}{4}$	15	1			Lining Mat.	$8\frac{5}{8}$ x $14\frac{1}{4}$	15	1		
ver Mat.	X					Lining Mat.	X				
rt. Pckt.	X					Horz. Pckt.	X				
rt. Pckt.	X					Horz. Pckt.	X				
ocket	X					Pocket	X				
el Holder	X					Card Holder	X				
terial	X					Material	X				
terial	X					Material	X				
terial	X					Material	X				
C. Board	$7\frac{21}{32}$ x $4\frac{7}{32}$	100	1			B.B. Board	$7\frac{21}{32}$ x $1\frac{1}{32}$	100	2		
C. Board	$7\frac{21}{32}$ x $4\frac{7}{32}$	100	1			B.B. Board	$7\frac{21}{32}$ x $1\frac{9}{32}$	100	1		
ter Board	X					Board	X				
ard	X					Strip	X				
ver Pad	X					Strip	X				
						B.B. Pad	X				

Product Code

OLD# 2721

Style Case QA-CAN-VIN

Sheet Size 11 X 9

Cap. 5 1/4 Die No. 4307

Order No. 963808

Plate

Customer	NORTHWEST INDUSTRIAL SUPPLY
Material	
Total Vinyl	
Quantity	280
Date	10-20-89
Type Corners	
Radius	
Completed	10-25-89 BP

Gauge	Thick
Bar Seal 1014	1/16
Bar Seal #253	1/16
Bar Seal	

No. of Feet	
Bar Seal	
Bar Seal	
Bar Seal	

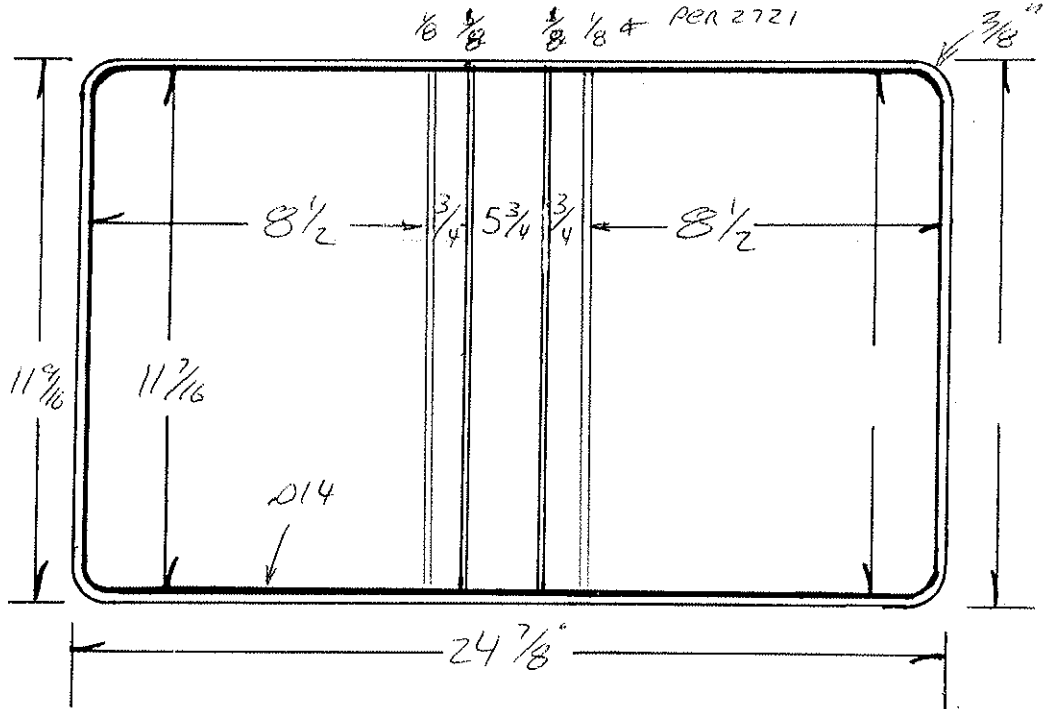

10-25

22 BY: B.P.

22 BY: *(Signature)*

(Signature)

Code		Cutting Specs				Code		Cutting Specs			
		Ga.	# PCS	Size	# Out			Ga.	# Pcs.	Size	# Out
Over Mat.	12 1/4 X 25 3/4	15	1			Lining Mat.	12 1/4 X 25 3/4	15	1		
Over Mat.	X					Lining Mat.	X				
rt. Pckt.	X					Horz. Pckt.	5 3/8 X 9		1		
rt. Pckt.	X					Horz. Pckt.	X				
Pocket	Die # X					Pocket	X				
Label Holder	3719 3 5/8 X 2 7/8	8	1			Card Holder	X				
Material	X					Material	X				
Material	X					Material	X				
Material	X					Material	X				
C. Board	11 1/32 X 8 13/32	120	1			B.C. Board	X				
C. Board	11 1/32 X 8 13/32	120	1			B.B. Board	11 1/32 X 2 1/32	120	2		
Center Board	11 1/32 X 5 21/32	120	1			Board Strip	11 1/32 X 2 1/32	120			
Card	FC 11 3/8 X 8 7/16	100	1			Strip	BB 11 3/8 X 5 21/32	100	1		
Over Pad	BC 11 3/8 X 8 7/16	100	1			Strip	Strip 11 3/8 X 2 1/32	100	2		
						B.B. Pad	X				

Product Code

Style Case CLAN-VIN

Sheet Size 11 X 9

Cap. 6 1/8 Die No. 4382

Order No. 964828

Plate

Customer

ACE ELECTRIC

Metal
Total Vinyl
Quantity <u>1000</u>
Date <u>2-16-90</u>
Type Corners
Radius <u>3/8"</u>
Completed

	Gauge	Thick
Tear Seal	<u>1014</u>	<u>1/2"</u>
Bar Seal	<u>#254</u>	<u>3/32"</u>
Bar Seal		

	No. of Feet
Tear Seal	
Bar Seal	
Bar Seal	

425
check
KW

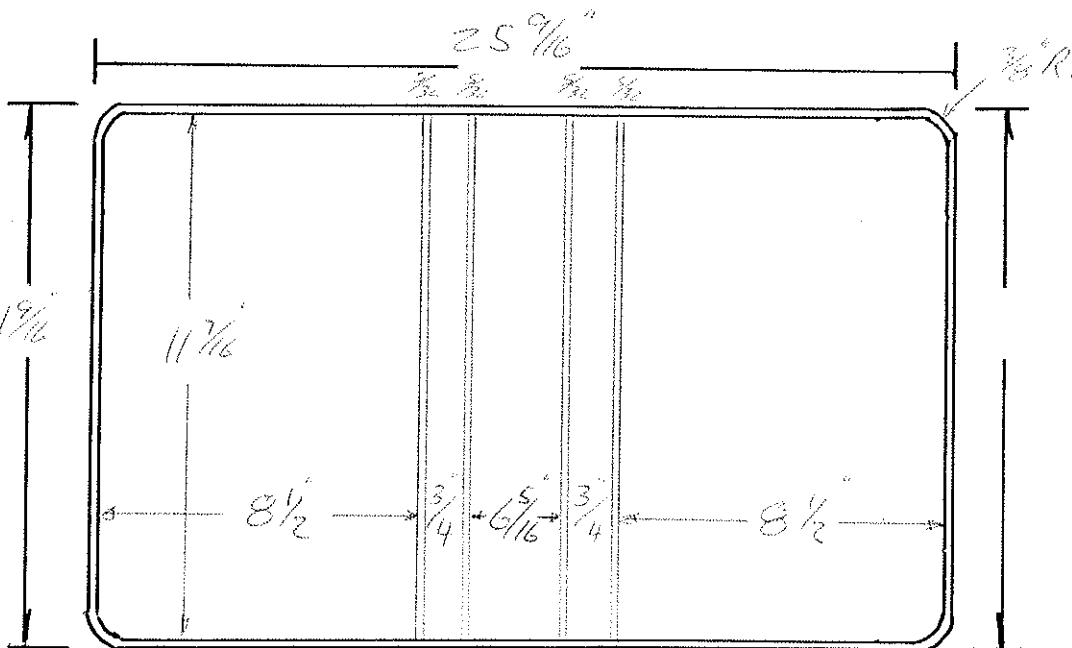

Code		Cutting Specs		Code		Cutting Specs			
		Ga.	# PCS	Size	Out	Ga.	# Pcs.	Size	Out
Cover Mat.	<u>12 1/4 X 26 1/2</u>	<u>15</u>	<u>1</u>			Lining Mat.	<u>12 1/4 X 26 1/2</u>	<u>15</u>	<u>1</u>
Cover Mat	X					Lining Mat.	X		
Vert. Pckt.	X					Horz. Pckt.	X		
Vert. Pckt.	X					Horz. Pckt.	X		
Pocket	X					Pocket	X		
Label Holder	X					Card Holder	X		
Material	X					Material	<u>Co. 1. 11 1/16 X 18"</u>	<u>8</u>	<u>1</u>
Material	X					Material	X		
Material	X					Material	X		
F.C. Board	<u>11 1/32 X 8 7/16</u>	<u>120</u>	<u>1</u>			B.C. Board	X		
B.G. Board	<u>11 1/32 X 8 7/16</u>	<u>100</u>	<u>1</u>			B.B. Board	<u>11 3/8 X 2 1/32</u>	<u>100</u>	<u>2</u>
Center Board	<u>flex 11 1/32 X 6 1/32</u>	<u>36</u>	<u>1</u>			Board	<u>11 1/32 X 2 1/32</u>	<u>100</u>	
Board	X					Strip	X		
Cover Pad	X					Strip	X		
FC Board	<u>11 3/8 X 8 7/16</u>	<u>100</u>				B.B. Pad	X		
BC Board	<u>11 3/8 X 8 7/16</u>	<u>100</u>							

OLD # 140 184 112

Product Code

Style Case WA CAN VIN

Sheet Size 11 X 9

Cap. 2 1/2

Die No. 4386

Order No. 964898

Plate

HOLSTON BUILDING SUPPLY

Customer	
Material	
Total Vinyl	
Quantity	200
Date	3-23-90
Type Corners	
Radius	7/16"
Completed	

	Gauge	Thick
Bar Seal	014	1/16"
Wire Seal	2254	3/16"
Wire Seal		

	No. of Feet
Bar Seal	
Wire Seal	
Wire Seal	

3120 - B Plate
 21000
 KPV

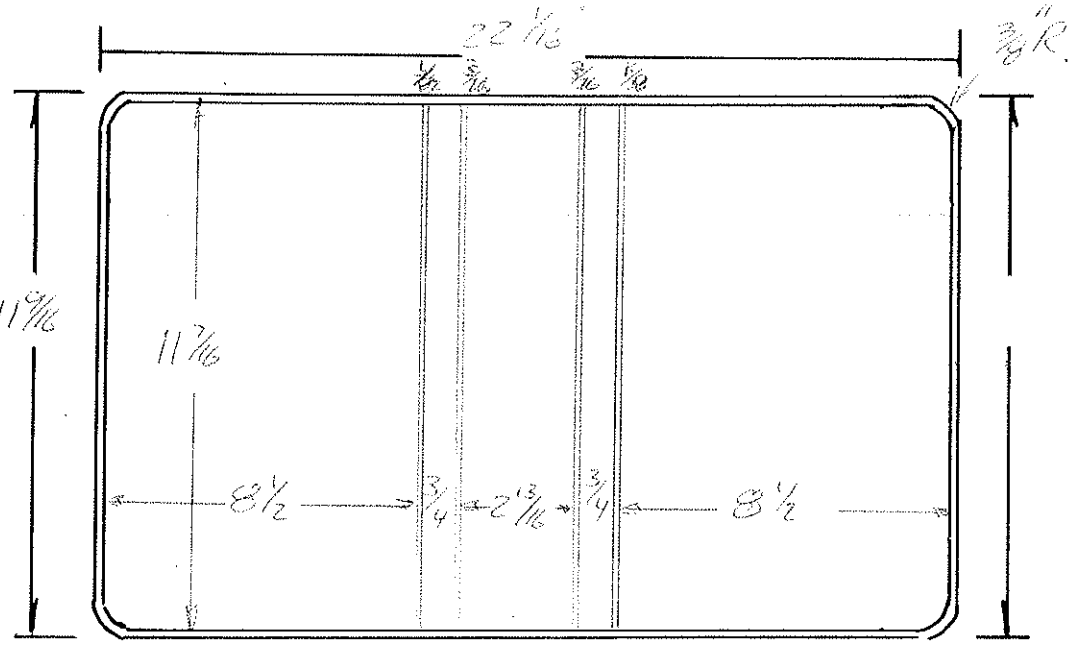

Code	Ga.	# PCS	Cutting Specs		Code	Ga.	# Pcs.	Cutting Specs	
			Size	Out				Size	Out
Over Mat.		15	12 1/4 X 22 7/16		Lining Mat.	15	1	12 1/4 X 22 7/16	
Over Mat			X		Lining Mat.			X	
rt. Pckt.			X		Horz. Pckt.			X	
rt. Pckt.			X		Horz. Pckt.			X	
Pocket			X		Pocket			X	
Panel Holder			X		Card Holder			X	
Material			X		Material			X	
Material			X		Material			X	
Material			X		Material			X	
C. Board		120	11 1/32 X 8 13/32	1	B.C. Board			X	
C. Board		120	11 1/32 X 8 13/32	1	B.B. Board		120	2	11 1/32 X 2 1/32
Water Board		100	11 1/32 X 2 23/32	1	Board		100		11 3/8 X 2 1/32
Board	Fixed	100	11 1/32 X 2 23/32	1	Strip			X	
Over Pad			X		Strip			X	
C. Board		100	11 3/8 X 8 7/16		B.B. Pad			X	
C. Board		100	11 3/8 X 8 7/16						
B.B.		100	11 3/8 X 2 3/4						

Specs - 4

Product Code

Style Case *QA-CAN-VIN*

Sheet Size *11 X 9*

Cap. *1/2*

Die No. *4390*

Order No. *965003*

Plate

Customer

WOLVERINE TRACTOR & EQUIP.

Metal
Total Vinyl
Quantity <i>50</i>
Date <i>5-7-90</i>
Type Corners
Radius <i>1/2"</i>
Completed

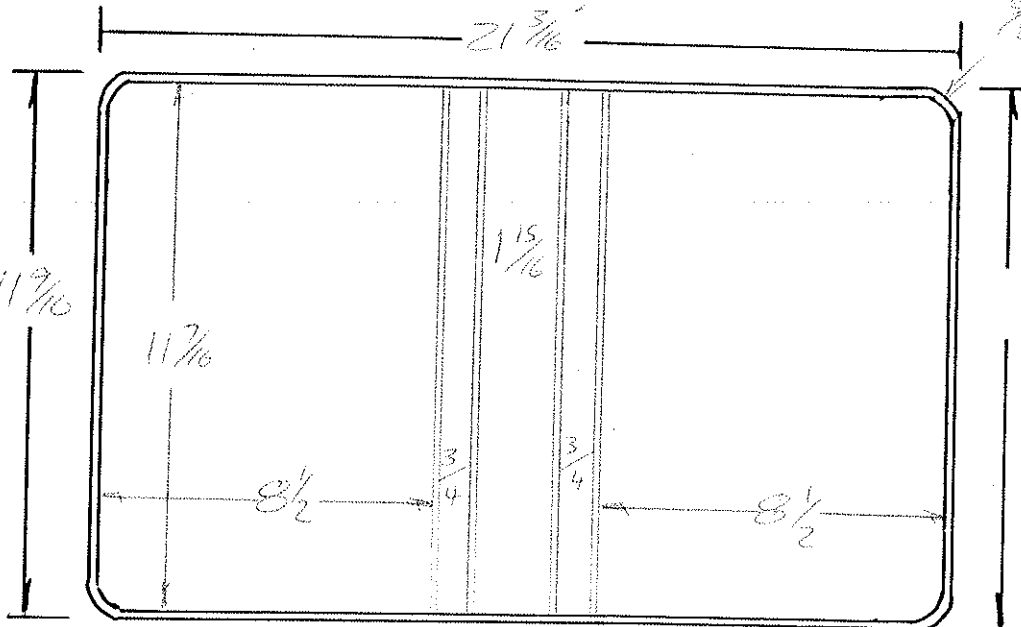

	Gauge	Thick
Tear Seal	<i>214</i>	<i>1/16</i>
Bar Seal	<i>2254</i>	<i>1/16</i>
Bar Seal		

	No. of Feet
Tear Seal	
Bar Seal	
Bar Seal	

See - B Page

Check - (4P ✓)

Code	Cutting Specs				Code	Cutting Specs			
	Ga.	# PCS	Size	Out		Ga.	# Pcs.	Size	Out
Cover Mat.			<i>12 1/4 X 22</i>		Lining Mat.			<i>12 1/4 X 22</i>	
Cover Mat			X		Lining Mat.			X	
Vert. Pckt.			X		Horz. Pckt.			X	
Vert. Pckt.			X		Horz. Pckt.			X	
Pocket			X		Pocket	<i>BB COL</i>		<i>11 1/16 X 3</i>	<i>per B.P</i>
Label Holder			X		Card Holder			X	
Material			X		Material			X	
Material			X		Material			X	
Material			X		Material			X	
F.C. Board			<i>11 1/8 X 8 7/16</i>	<i>100</i>	B.C. Board			X	
B.C. Board			<i>11 1/8 X 8 7/16</i>	<i>100</i>	B.B. Board			<i>11 1/8 X 1 27/32</i>	<i>100</i>
Center Board			X		Board			X	
Board			X		Strip			<i>11 1/32 X 2 1/32</i>	<i>100</i>
Cover Pad			X		Strip			<i>11 3/8 X 2 1/32</i>	<i>100</i>
FC Board			<i>11 3/8 X 8 7/16</i>	<i>100</i>	B.B. Pad			X	
BC Board			<i>11 3/8 X 8 7/16</i>	<i>100</i>					
BB Board			<i>11 3/8 X 1 7/16</i>	<i>100</i>					

Product Code

Style Case QVA-CAN-VIN 3 1/2 FXD.

Sheet Size 11 x 9

Cap. 3 1/2

Die No. 4554

Order No. 966747

Plate

SOUTHERN CO. SERVICES

Customer

Material	
Total Vinyl	
Quantity	50
Date	9-28-90
Type Corners	
Radius	3/16
Completed	

	Gauge	Thick
ear Seal	014	1/16
ar Seal	+254	3/32
ar Seal		

	No. of Feet
ear Seal	
ar Seal	
ar Seal	

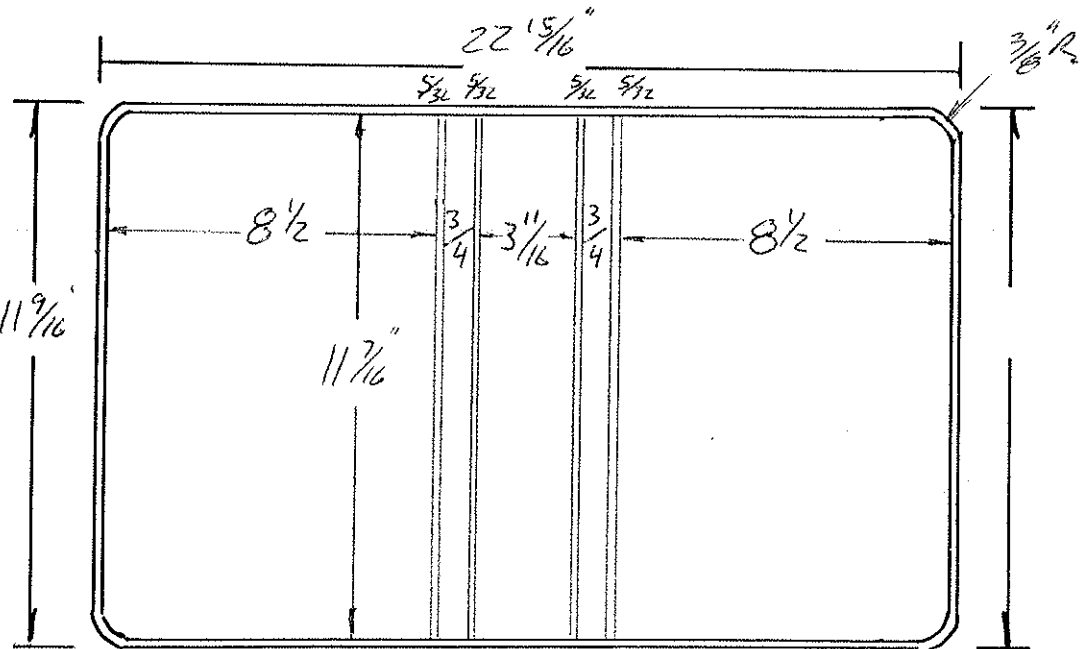

12c B.P.
 each
 (Handwritten signature/initials)
 Case only

Code	Ga.	PCS	Cutting Specs		Code	Ga.	Pcs.	Cutting Specs	
			Size	Out				Size	Out
over Mat.		12 1/4 x 23 3/4	14	1	Lining Mat.		12 1/4 x 23 3/4	14	1
over Mat		X			Lining Mat.		X		
ert. Pckt.		X			Horz. Pckt.		X		
ert. Pckt.		X			Horz. Pckt.		X		
Pocket		X			Pocket		X		
abel Holder		X			Card Holder FC-BB		X		
aterial		X			Material COL. → 11 1/16 x 15 3/8	8	1		
aterial		X			Material		X		
aterial		X			Material		X		
.C. Board		11 1/32 x 8 13/32	100	1	B.C. Board		X		
.C. Board		11 1/32 x 8 13/32		1	B.B. Board		11 1/32 x 3 19/32	100	1
enter Board		X			Board		11 1/32 x 2 1/32	100	2
oard		X			Strip		11 3/8 x 2 1/32	100	
over Pad		X			Strip		X		
					B.B. Pad		X		
FC Board		8 7/16 x 11 3/8	100	1					
BC Board		8 7/16 x 11 3/8	100	1					
BB Board		11 3/8 x 3 19/32	100	1					

Product Code

Style Case QVA-CAN-VIN

Sheet Size 11 x 9

Cap. 2 1/4 Die No. 4673

Order No. 9767939

Plate

Customer

DELTA FOREMOST CHEMICAL

Metal
Total Vinyl
Quantity <u>150</u>
Date <u>2-27-91</u>
Type Corners
Radius
Completed

	Gauge	Thick
Tear Seal	<u>014</u>	<u>1/16</u>
Bar Seal	<u>#254</u>	<u>5/32</u>
Bar Seal		

	No. of Feet
Tear Seal	
Bar Seal	
Bar Seal	

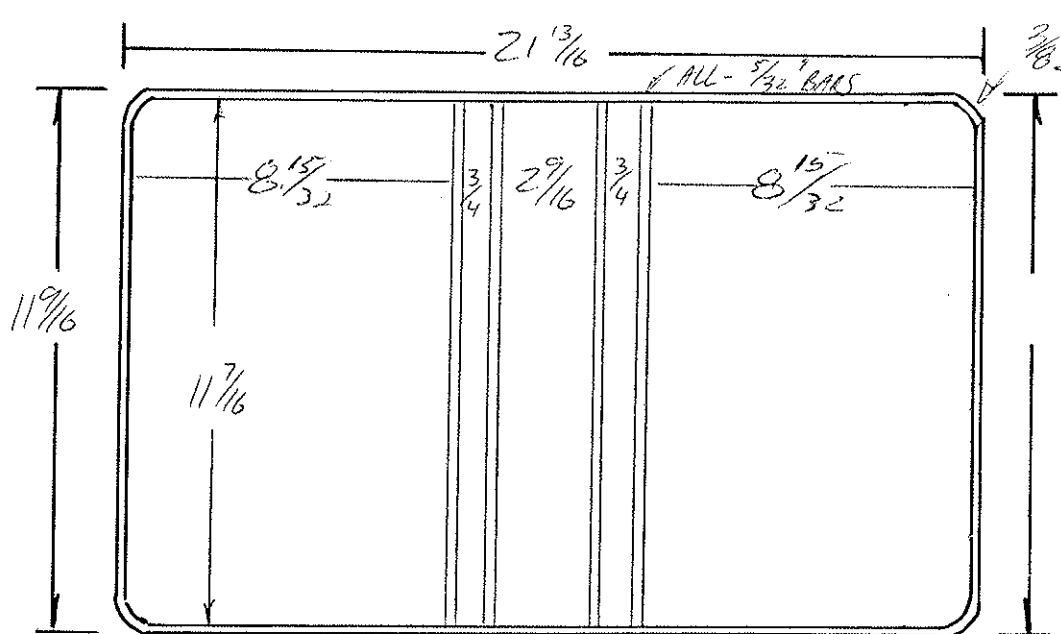

SEE - Bl. Acc
CHECK - KPN

Code	Ga.	# PCS	Cutting Specs		Code	Ga.	# Pcs.	Cutting Specs					
			Size	Out				Size	Out				
Cover Mat.			12 1/4	X 22 5/8	15	1	Lining Mat.			12 1/4	X 22 5/8	15	1
Cover Mat.				X			Lining Mat.				X		
Vert. Pckt.				X			Horz. Pckt.				X		
Vert. Pckt.				X			Horz. Pckt.				X		
Pocket				X			Pocket				X		
Label Holder				X			Card Holder				X		
Material				X			Material				X		
Material				X			Material				X		
Material				X			Material				X		
F.C. Board			11 1/32	X 8 3/8	120	1	B.C. Board				X		
B.C. Board			11 1/32	X 8 3/8	120	1	B.B. Board			11 1/32	X 2 1/32	120	2
Center Board			11 1/32	X 2 5/32	20	1	Board				X		
BB Board			11 1/32	X 2 5/32	120	1	Strip			11 3/8	X 2 1/32	100	2
Cover Pad				X			Strip				X		
							B.B. Pad				X		
FC Board			11 3/8	X 8 13/32	100	1							
BC Board			11 3/8	X 8 13/32	100	1							
BB Board			11 3/8	X 2 15/32	100	1							
			11 3/8	X 2 15/32	20	1							

Product Code

VINYL
Style Case COA-CAN-VIN BINDER

Sheet Size 11 x 9

Cap. 3-4 1/2 exp. Die No. 4981

Order No. 971048

Plate D-3-

2-9

Customer

Metal
Total Vinyl
Quantity 50
Date 1-29-92
Type Corners
Radius 3/8
Completed

	Gauge	Thick
Tear Seal	.014	1/16
Bar Seal	48-4	5/32"
Bar Seal		

	No. of Feet
Tear Seal	
Bar Seal	
Bar Seal	

Dwg. B. P. Inc

CHLH-

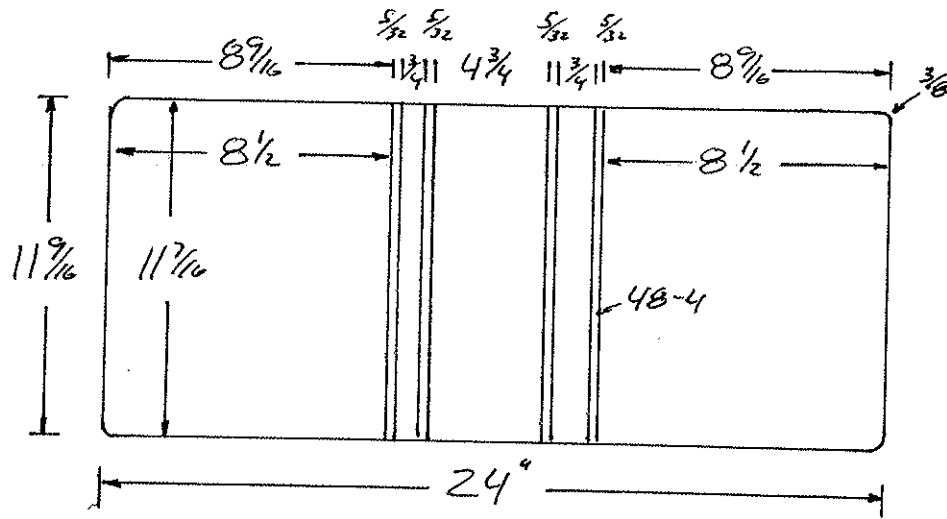

Code		Cutting Specs		Code		Cutting Specs				
		Ga.	PCS	Size	Out	Ga.	Pcs.	Size	Out	
Cover Mat.	12 1/4 x 24 3/4		1			Lining Mat.		12 1/4 x 24 3/4		1
Cover Mat.	X					Lining Mat.	X			
Vert. Pckt.	X					Horz. Pckt.	X			
Vert. Pckt.	X					Horz. Pckt.	X			
Pocket	X					Pocket	X			
Label Holder	Full X					Card Holder	X			
Material	COL. 11 1/16 x 24 3/4	8	1			Material	X			
Material	X					Material	X			
Material	X					Material	X			
F.C. Board	11 1/32 x 8 13/32	120	1			B.C. Board	11 3/8 x 8 7/16	100	1	
B.C. Board	11 1/32 x 8 13/32	120	1			B.B. Board	11 3/8 x 4 21/32	100	1	
Center Board	11 1/32 x 4 21/32	20	1			PC Board	11 3/8 x 8 7/16	100	1	
Board	11 1/32 x 2 1/32	120	2			Strip	11 3/8 x 2 1/32	100	2	
Cover Pad	X					Strip	X			
						B.B. Pad	X			

Specs 4
Cutting Specs.

DIE #	5924 A+B	METAL	QVC	RADIUS	3/8
ORDER #	982713	CUSTOMER	FORNEY INTERNATIONAL	TEAR SEAL	.014
SHEET SIZE	11 x 9	STYLE CASE	VRB / COL	BAR SEAL	253
CAP.	1"	DUE DATE	10-26-95	COMPLETED	
LOCATION	F-14-7	QUANTITY	500	DATE	10-4-95

5924-A

DIE 5924-B

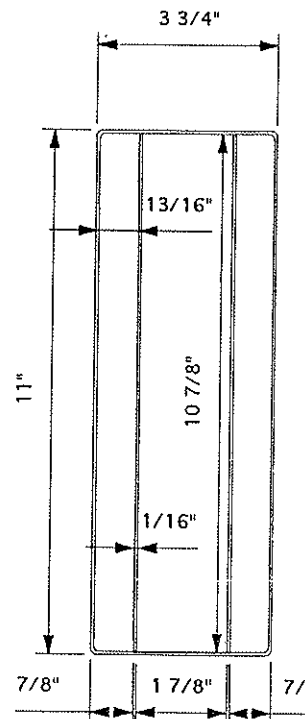
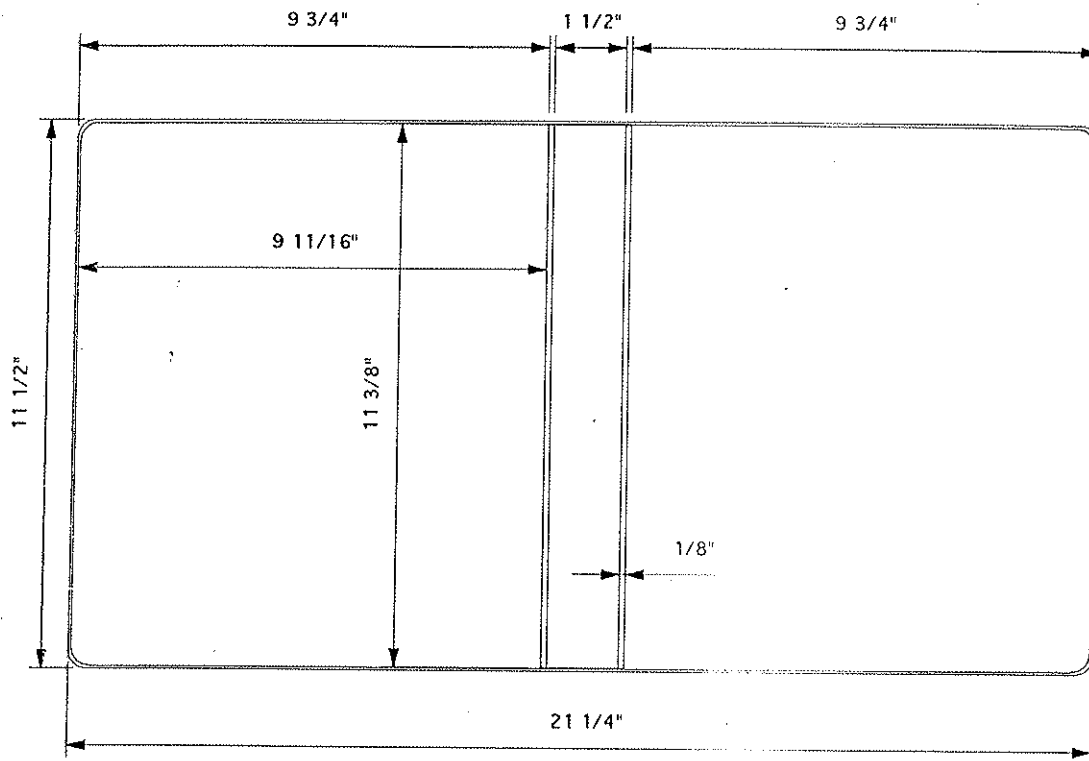

MATERIAL SPECS		GAUGE		PC.		MATERIAL SPECS		GAUGE	
COVER MAT.	12 1/4 X 22	DIE 5924-A		1	LINING MAT.	12 1/4 X 22	DIE 5924-A		
COVER MAT.	11 3/4 X 4 1/2	DIE 5924-B		1	LINING MAT.	11 3/4 X 4 1/2	DIE 5924-B		
DIE CUT					HORZ. PKT.				
COL	11 5/8 X 12 1/8			1	VERT. PKT.				
LABEL HOLDER					DIE CUT				
GUSSET					REINF.				

BOARD SPECS		GAUGE		PC.		BOARD SPECS		GAUGE	
F.C. BOARD	11 5/16 X 9 5/8	100	1	F.C. BOARD					
B.B. BOARD	11 5/16 X 1 13/32	100	1	B.B. BOARD	10 25/32 X 11/16			100	
B.C. BOARD	11 5/16 X 9 5/8	100	1	B.C. BOARD	DIE 5924-B				
B.U. STRIP	DIE 5924-A			DIE CUT					
DIE CUT				DIE CUT					

DIE #	6149 A-B	METAL	QVC	RADIUS	3/8
ORDER #		CUSTOMER	FORNEY INTERNATIONAL	TEAR SEAL	.014
SHEET SIZE	11 x 9	STYLE CASE	VRB / COL	BAR SEAL	253
CAP.	2"	DUE DATE	11-20 96	COMPLETED	
LOCATION	G-2-9	QUANTITY	200	DATE	11-12-96

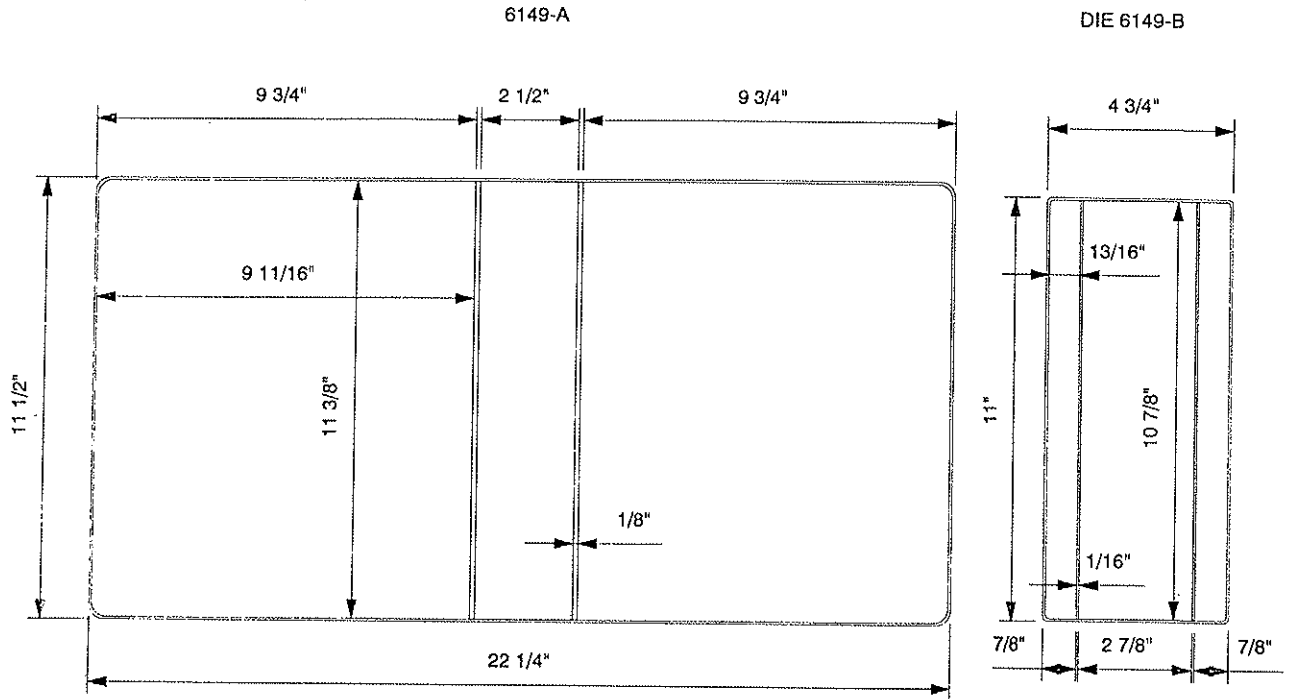

MATERIAL SPECS		GAUGE		MATERIAL SPECS		GAUGE	
COVER MAT.	12 1/4 X 23		1	LINING MAT.	12 1/4 X 23		1
COVER MAT.	11 3/4 X 5 1/2		1	LINING MAT.	11 3/4 X 5 1/2		1
DIE CUT				HORZ. PKT.			
COL	11 5/8 X 13		1	VERT. PKT.			
LABEL HOLDER				DIE CUT			
GUSSET				REINF.			

BOARD SPECS		GAUGE		BOARD SPECS		GAUGE	
F.C. BOARD	11 5/16 X 9 5/8	100	1	F.C. BOARD	10 9/16 x 2 1/32		2
B.B. BOARD	11 5/16 X 2 13/32	100	1	B.B. BOARD	10 25/32 X 11/16	100	2
B.C. BOARD	11 5/16 X 9 5/8	100	1	B.C. BOARD			
B.U. STRIP				DIE CUT			
DIE CUT				DIE CUT			

DIE #	6150 A-B	METAL	QVC	RADIUS	3/8
ORDER #		CUSTOMER	FORNEY INTERNATIONAL	TEAR SEAL	.014
SHEET SIZE	11 x 9	STYLE CASE	VRB / COL	BAR SEAL	253
CAP.	3"	DUE DATE	11-20 96	COMPLETED	
LOCATION	G-2-8	QUANTITY	200	DATE	11-12-9

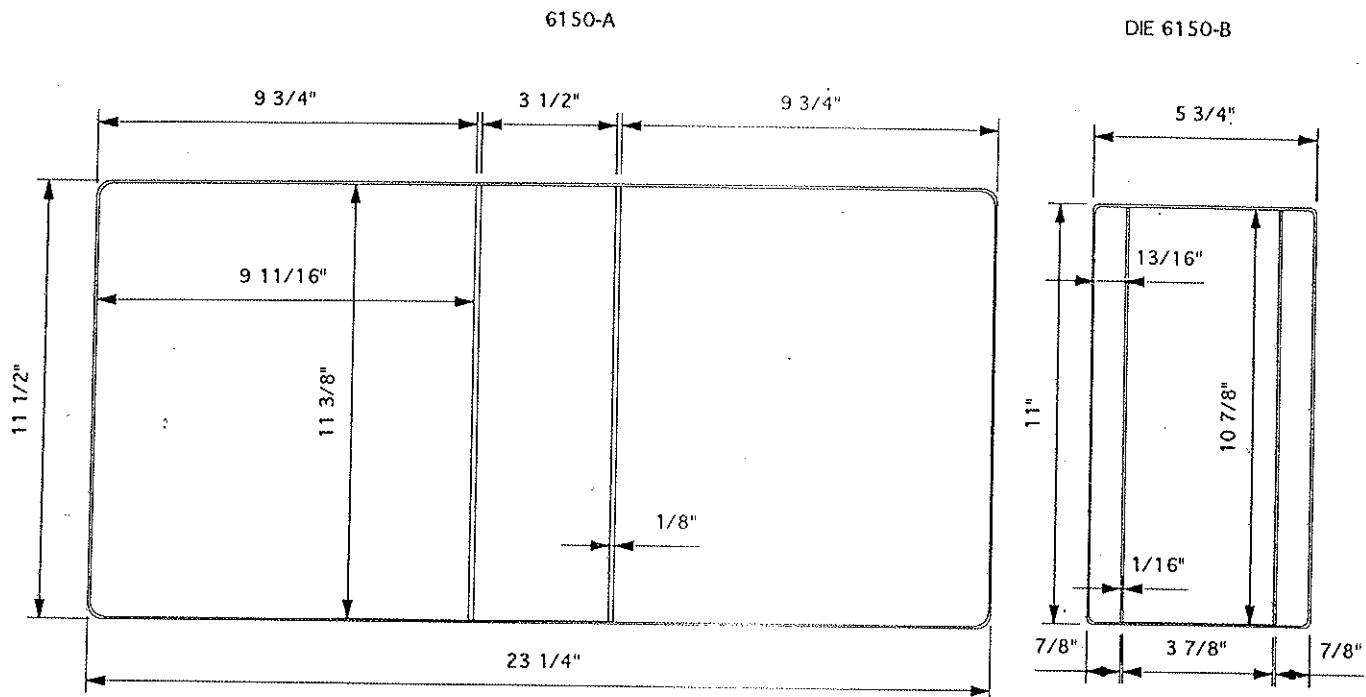

MATERIAL SPECS		GAUGE		PCSS		MATERIAL SPECS		GAUGE P	
COVER MAT.	12 1/4 X 24		1	LINING MAT.	12 1/4 X 24				
COVER MAT.	11 3/4 X 6 1/2		1	LINING MAT.	11 3/4 X 6 1/2				
DIE CUT				HORZ. PKT.					
COL	11 5/8 X 14		1	VERT. PKT.					
LABEL HOLDER				DIE CUT					
GUSSET				REINF.					
BOARD SPECS		GAUGE		PCSS		BOARD SPECS		GAUGE P	
F.C. BOARD	11 5/16 X 9 5/8	100	1	F.C. BOARD					
B.B. BOARD	11 5/16 X 3 13/32	100	1	B.B. BOARD	10 25/32 X 11/16			100	
B.C. BOARD	11 5/16 X 9 5/8	100	1	B.C. BOARD					
B.U. STRIP				DIE CUT					
DIE CUT				DIE CUT					

DIE #	6298-A	METAL	QCV EXPANDABLE	RADIUS	3/8"
ORDER #	987690	CUSTOMER	THOMAS & BETTS	TEAR SEAL	.014
SHEET SIZE	11 X 9	STYLE CASE	VINYL QUA CAN VIN	BAR SEAL	254
CAP.	5-7	DUE DATE	8-27-97	COMPLETED	
LOCATION		QUANTITY	10,000	DATE	7-30-97

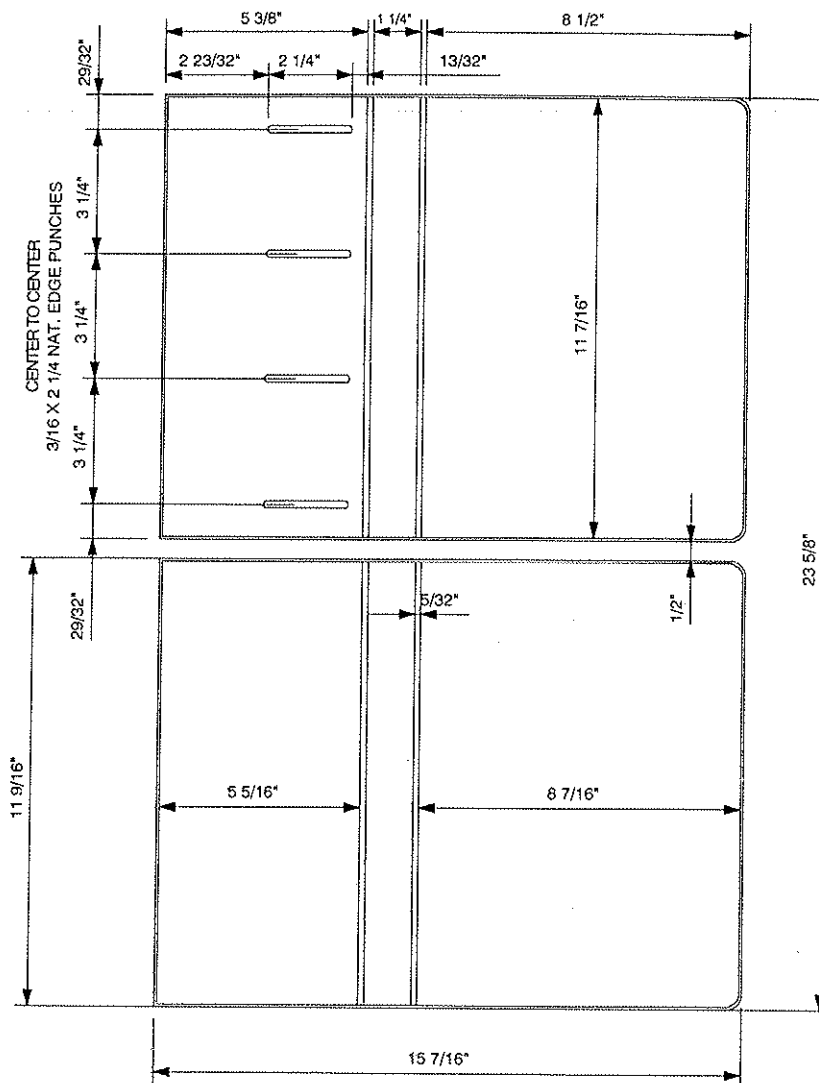

MATERIAL SPECS		GAUGE PCS.		MATERIAL SPECS		GAUGE F	
COVER MAT.	24 5/8 X 16 1/2		1	LINING MAT.	24 5/8 X 16 1/2		
PICTORIAL				LINING MAT.			
LABEL HOLDER				HORZ. PKT.			
COL				HORZ. PKT.			
EX COL NO TRIM				ONE SIDED			
EX COL				ONE SIDED			

NORMAL 1/16" TOL		PCS.		EXPANDED MATERIAL BOARD TOL. (3/32")		P.	
F.C. BOARD	11 3/8 X 8 3/8	120	1	F.C. BOARD			
B.B. BOARD	11 3/8 X 5 1/4	100	1	B.B. BOARD			
B.C. BOARD	11 3/8 X 8 3/8	120	1	B.C. BOARD			
BOARD	11 3/8 X 1 5/32	120	2	DIE CUT			

DIE #	6383	METAL	QVC	RADIUS	3/8
ORDER #	77015	CUSTOMER	FORNEY INTERNATIONAL	TEAR SEAL	.014
SHEET SIZE	11 x 9	STYLE CASE	VRB / COL	BAR SEAL	253
CAP.	1 1/2"	DUE DATE	12-18-97	COMPLETED	
LOCATION	G-13-4	QUANTITY	590	DATE	12-3-97

6383-A

DIE 6383-B

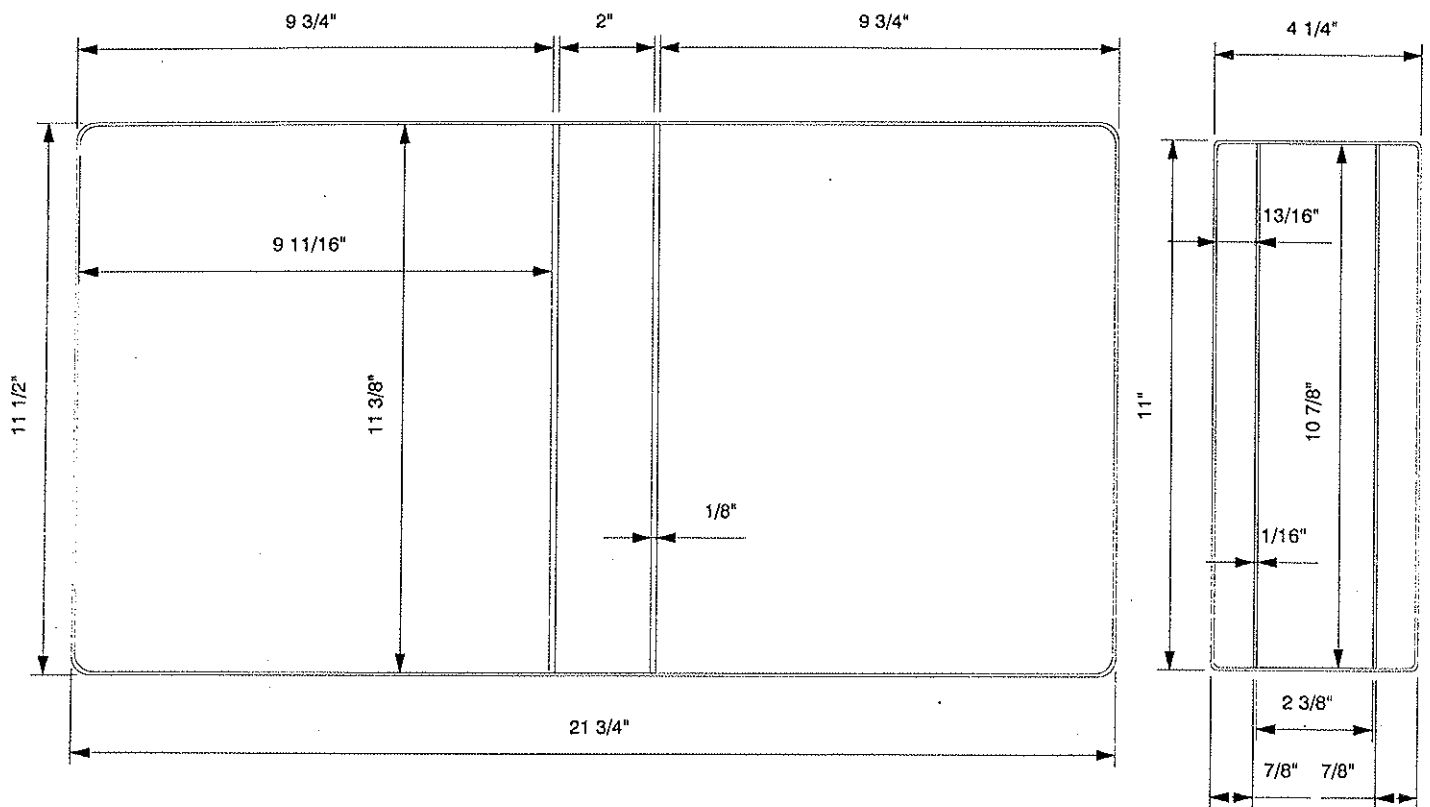

MATERIAL SPECS		GAUGE		PCS.		MATERIAL SPECS		GAUGE		PCS.	
COVER MAT.	12 1/4 X 22 1/2	DIE 6383-A		1	LINING MAT.	12 1/4 X 22 1/2	DIE 6383-A		1		
COVER MAT.	11 3/4 X 5	DIE 6383-B		1	LINING MAT.	11 3/4 X 5	DIE 6383-B		1		
DIE CUT					HORIZ. PKT.						
COL	11 5/8 X 12 3/8			1	VERT. PKT.						
LABEL HOLDER					DIE CUT						
GUSSET					REINF.						

BOARD SPECS		GAUGE		PCS.		BOARD SPECS		GAUGE		PCS.	
F.C. BOARD	11 5/16 X 9 5/8	100	1	F.C. BOARD							
B.B. BOARD	11 5/16 X 1 29/32	100	1	B.B. BOARD	10 25/32 X 11/16		100	2			
B.C. BOARD	11 5/16 X 9 5/8	100	1	B.C. BOARD	DIE 6383-B						
B.U. STRIP	DIE 6383-A			DIE CUT							
DIE CUT				DIE CUT							

DIE #	6688	METAL	5-7.5 EXPANDABLE QCV	RADIUS	3/8"
ORDER #	232346	CUSTOMER	PEP BOYS	TEAR SEAL	.014
SHEET SIZE	11 X 9	STYLE CASE	VINYL QCV	BAR SEAL	254
CAP.	5-7.5	DUE DATE	5-7-99	COMPLETED	
LOCATION	1-12-1	QUANTITY	250	DATE	4-23-99

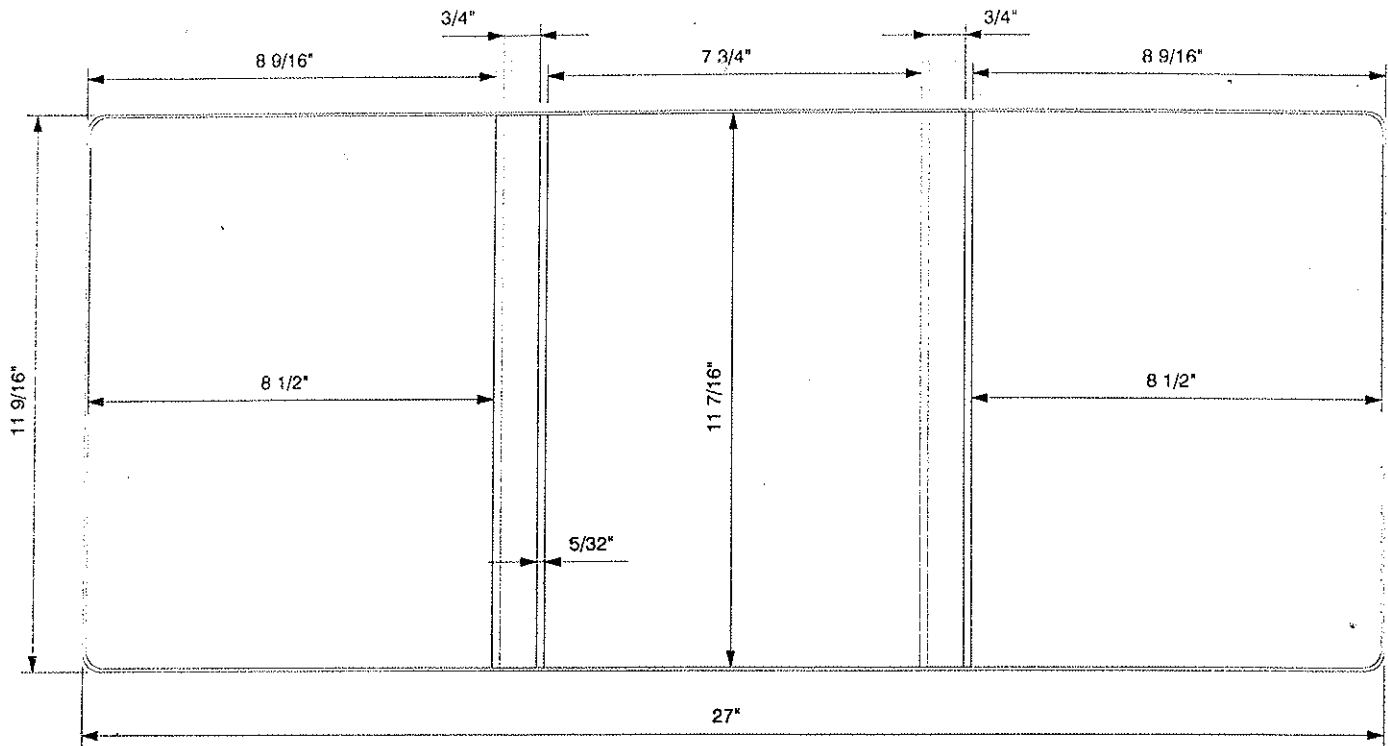

MATERIAL SPECS		GAUGE	PCS.	MATERIAL SPECS	GAUGE	PCS.
COVER MAT.	12 5/16 X 27 3/4		1	LINING MAT.	12 5/16 X 27 3/4	1
COVER MAT.				LINING MAT.		
DIE CUT				HORZ. PKT.		
COL	11 1/16 x 18		1	VERT. PKT.		
LABEL HOLDER				DIE CUT		
GUSSET				REINF.		
BOARD SPECS		GAUGE	PCS.	BOARD SPECS	GAUGE	PCS.
F.C. BOARD	11 3/8 X 8 7/16	120	1	F.C. BOARD		
B.B. BOARD	11 3/8 X 7 11/16	22	1	B.B. BOARD		
B.C. BOARD	11 3/8 X 8 7/16	120	1	B.C. BOARD		
FLAP BD.				DIE CUT		
BOARD	11 3/8 X 21/32	120	2	DIE CUT		

DIE #	6968	METAL	QA CAN VIN FIXED	RADIUS	3/8"
ORDER #	361148	CUSTOMER	US FILTER	TEAR SEAL	.012
SHEET SIZE	11.75 X 8.75	STYLE CASE	VINYL A4 - QA CAN VIN	BAR SEAL	48-4
CAP.	2.5"	DUE DATE	8-21-00	COMPLETED	
LOCATION		QUANTITY	10	DATE	8-10-00

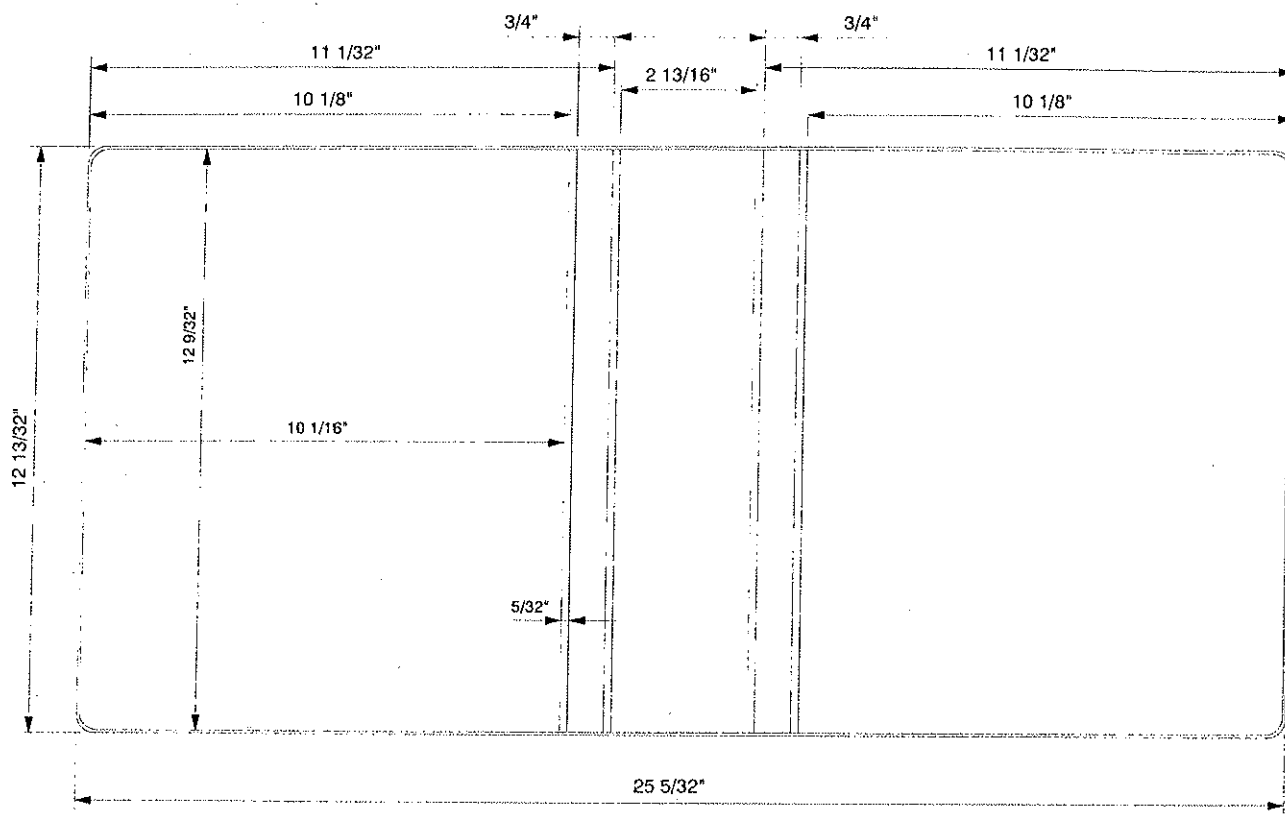

MATERIAL SPECS		GAUGE	PCS.	MATERIAL SPECS		GAUGE	PCS.
COVER MAT.	13 1/8 X 25 7/8		1	LINING MAT.	13 1/8 X 25 7/8		1
COVER MAT.				LINING MAT.			
DIE CUT				HORZ. PKT.			
COL				VERT. PKT.			
LABEL HOLDER				DIE CUT			
GUSSET				REINF.			
BOARD SPECS		GAUGE	PCS.	BOARD SPECS		GAUGE	PCS.
F.C. BOARD	12 7/32 X 10	120	1	F.C. BOARD			
B.B. BOARD	12 7/32 X 2 23/32	120	1	B.B. BOARD			
B.C. BOARD	12 7/32 X 10	120	1	B.C. BOARD			
FLAP BD.				DIE CUT			
BOARD	12 7/32 X 21/32	120	2	DIE CUT			

DIE #	7227	METAL	QVC	RADIUS	3/8
ORDER #	482265	CUSTOMER	MASTERBRAND CABINETS	TEAR SEAL	.014
SHEET SIZE		STYLE CASE	QA CAN VIN W/FLAP	BAR SEAL	48-4
CAP.	2" - 3"	DUE DATE	3-6-02	COMPLETED	
LOCATION		QUANTITY	2	DATE	3-4-02

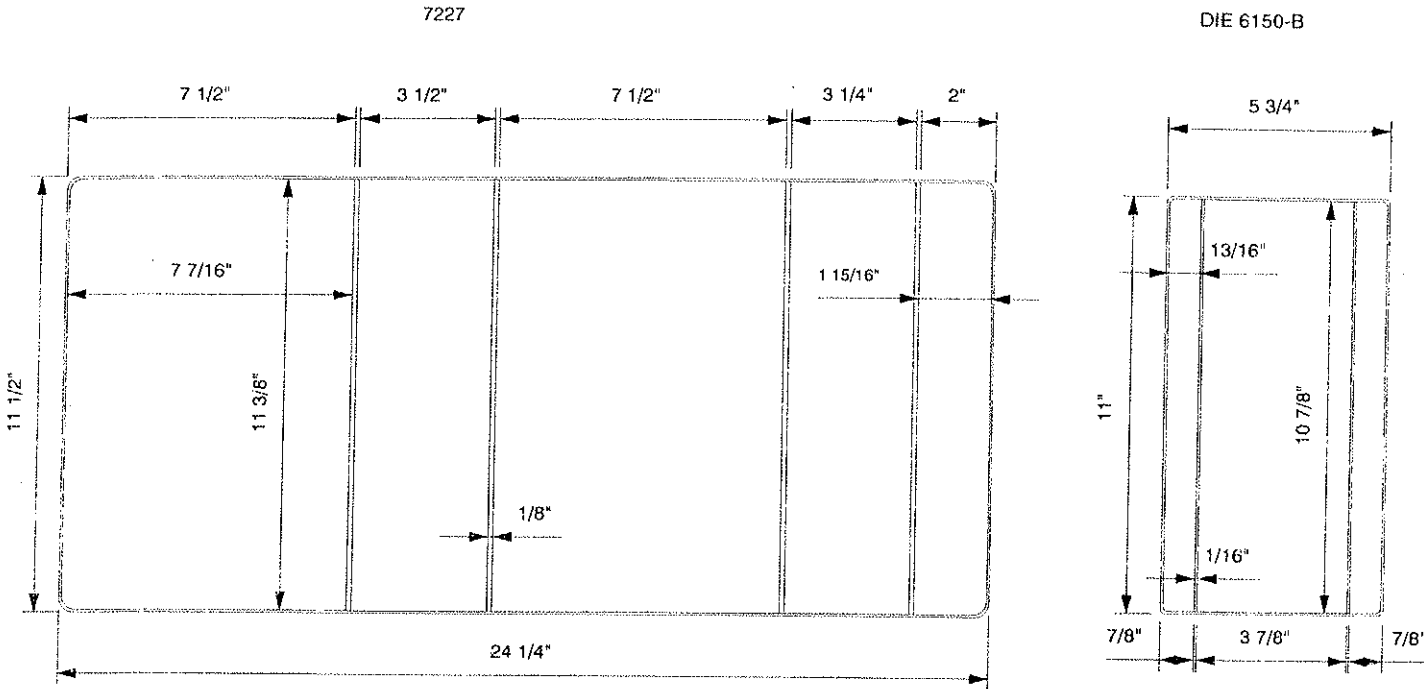

MATERIAL SPECS		GAUGE		PCS.		MATERIAL SPECS		GAUGE		PCS.	
COVER MAT.	12 1/2 X 25 1/4			1		LINING MAT.	12 1/4 X 25			1	
COVER MAT.	11 3/4 X 6 1/2	6150-B		1		LINING MAT.	11 3/4 X 6 1/2	6150-B		1	
DIE CUT						HORZ. PKT.					
COL						VERT. PKT.					
LABEL HOLDER						DIE CUT					
GUSSET						REINF.					
BOARD SPECS		GAUGE		PCS.		BOARD SPECS		GAUGE		PCS.	
F.C. BOARD	11 5/16 X 7 3/8			100	1	F.C. BOARD	11 5/16 X 1 27/32			100	1
B.B. BOARD	11 5/16 X 3 13/32			FLEX	1	B.B. BOARD	10 25/32 X 11/16	6150-B		100	2
B.C. BOARD	11 5/16 X 7 7/16			100	1	B.C. BOARD					
B.U. STRIP	11 5/16 X 3 5/32			FLEX	1	DIE CUT					
DIE CUT						DIE CUT					

DIE #	7695	METAL	QA CAN VIN POST	RADIUS	3/8"
ORDER #	622264	CUSTOMER	U O P LLC	TEAR SEAL	.014
SHEET SIZE	11 3/4 X 8 3/4	STYLE CASE	VINYL QVC BINDER	BAR SEAL	48-4
CAP.	3"	DUE DATE	6-25-04	COMPLETED	
LOCATION		QUANTITY	150	DATE	5-17-04

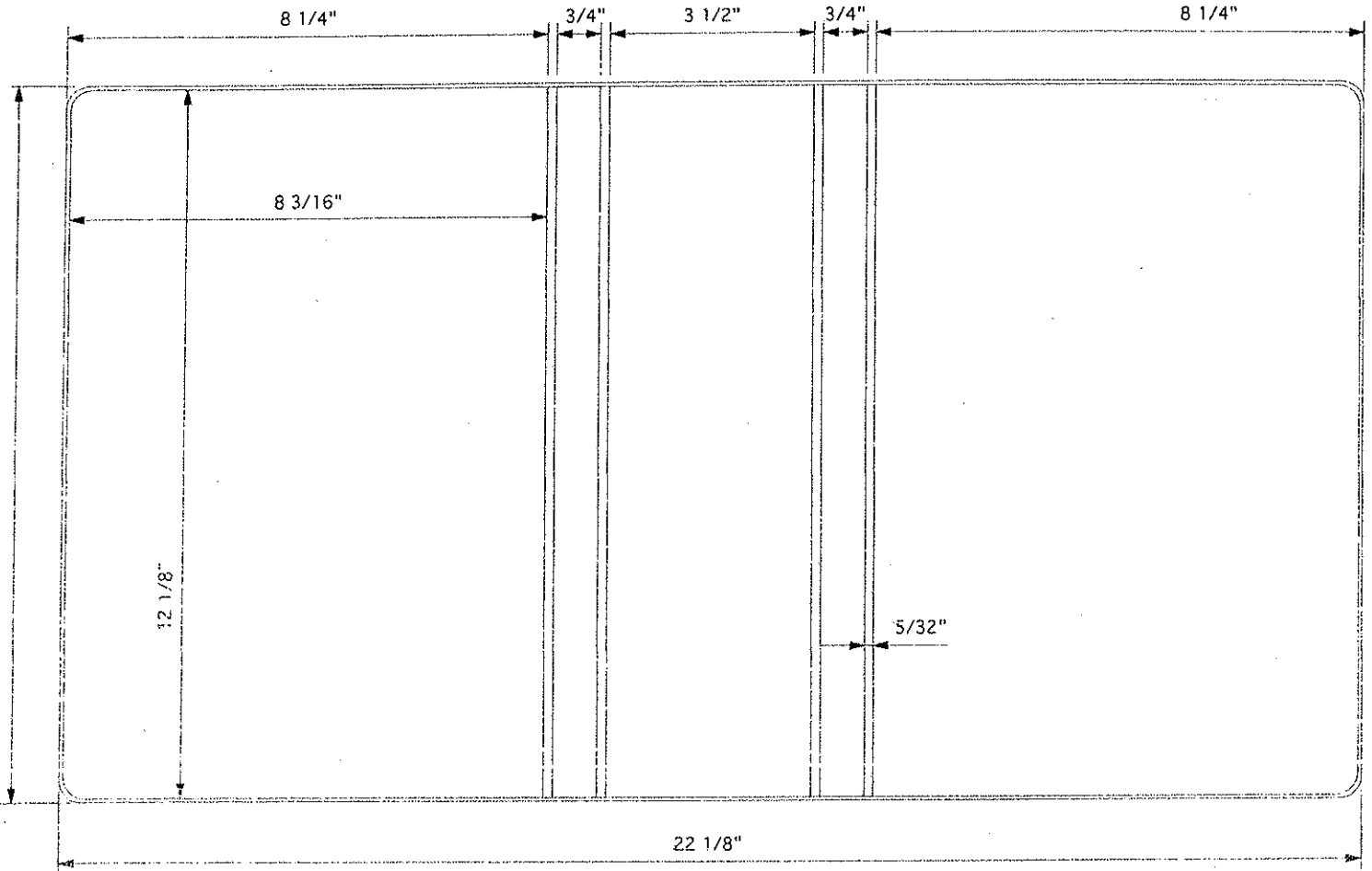

MATERIAL SPECS		GAUGE	PCS.	MATERIAL SPECS		GAUGE	PCS.
COVER MAT.	13 X 22 7/8		1	LINING MAT.	13 X 22 7/8		1
COVER MAT.				LINING MAT.			
DIE CUT				HORZ. PKT.	4 7/8 X 22 7/8		1
COL	12 3/8 X 13 3/8		1	VERT. PKT.			
LABEL HOLDER				DIE CUT			
GUSSET				REINF.			
BOARD SPECS		GAUGE	PCS.	BOARD SPECS		GAUGE	PCS.
F.C. BOARD	12 1/32 X 8 3/32	120	1	F.C. BOARD	5/16" R. CORNERS		
B.B. BOARD	12 1/32 X 3 13/32	120	1	B.B. BOARD			
B.C. BOARD	12 1/32 X 8 3/32	120	1	B.C. BOARD			
FLAP BD.				DIE CUT			
BOARD	12 1/32 X 21/32	120	2	DIE CUT			

Match Sample

DIE #	8405	METAL	QCV TWIN LOCK	RADIUS	1/2"
ORDER #	813562	CUSTOMER	INNOVATIVE MARKETING	TEAR SEAL	.014
SHEET SIZE	11 X 9	STYLE CASE	VINYL QUA CAN VIN	BAR SEAL	178
CAP.	4"	DUE DATE	12-3-07	COMPLETED	
LOCATION		QUANTITY	2000	DATE	10-25-07

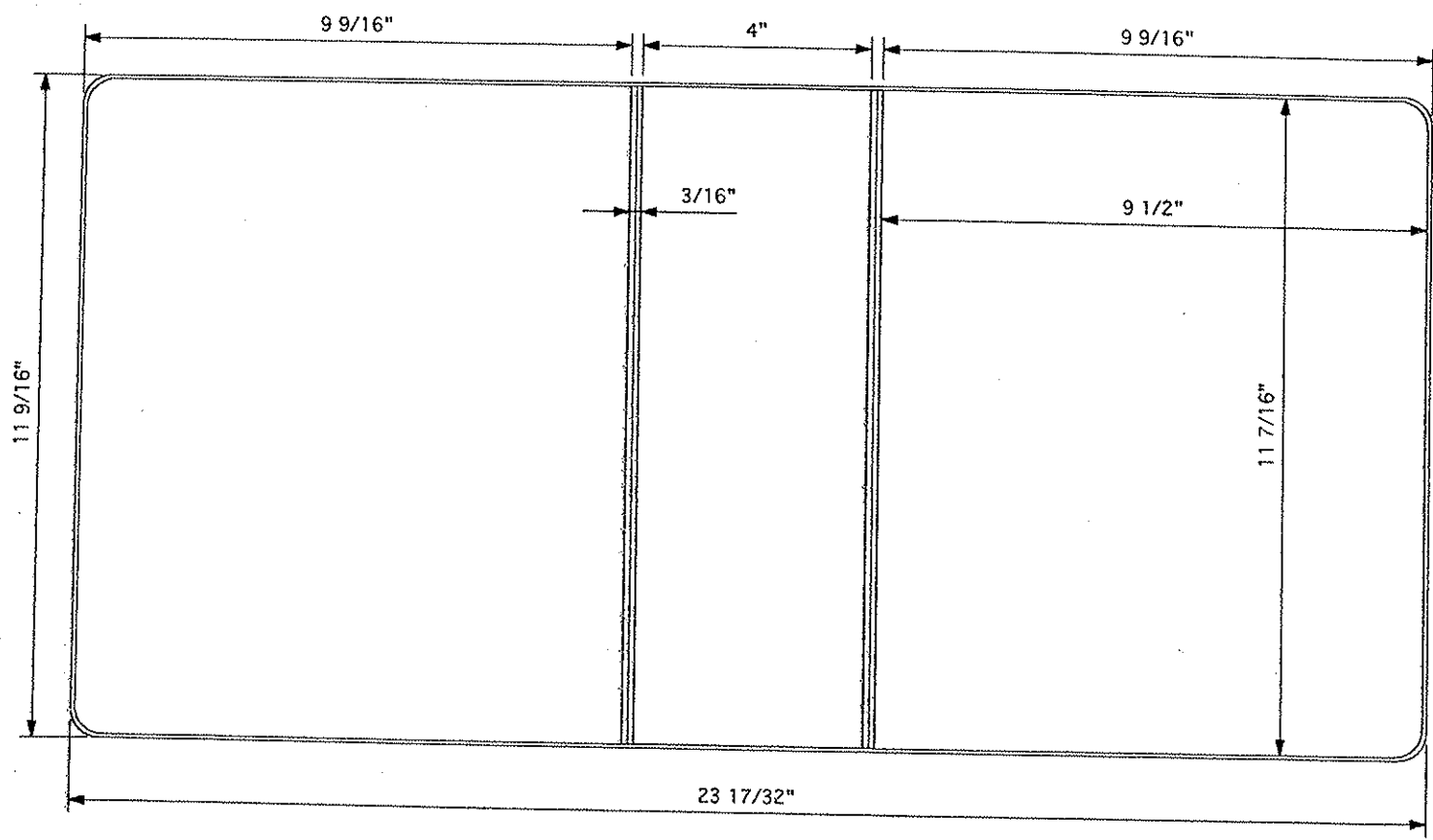

MATERIAL SPECS		GAUGE	PCS.	MATERIAL SPECS		GAUGE	PCS.
COVER MAT.	12 5/16 X 24 3/8		1	LINING MAT.	12 5/16 X 24 3/8		1
COVER MAT.				LINING MAT.			
DIE CUT				HORZ. PKT.			
COL	11 11/16 X 14 3/8		1	VERT. PKT.			
LABEL HOLDER				DIE CUT			
GUSSET				REINF.			
BOARD SPECS		GAUGE	PCS.	BOARD SPECS		GAUGE	PCS.
F.C. BOARD	11 11/32 X 9 13/32	120	1	F.C. BOARD	11 11/32 X 9 13/32	120	1
B.B. BOARD	11 11/32 X 3 29/32	120	1	B.B. BOARD	11 11/32 X 3 29/32	120	1
B.C. BOARD	11 11/32 X 9 13/32	120	1	B.C. BOARD	11 11/32 X 9 13/32	120	1
FLAP BD.				DIE CUT			
BOARD				DIE CUT			

DIE #	8642	METAL	QA CAN VIN POST	RADIUS	3/8"
ORDER #	878930	CUSTOMER	U O P LLC	TEAR SEAL	.014
SHEET SIZE	11 3/4 X 8 3/4	STYLE CASE	VINYL QVC BINDER	BAR SEAL	48-4
CAP.	2"	DUE DATE	2-3-09	COMPLETED	
LOCATION		QUANTITY	100	DATE	1-15-09

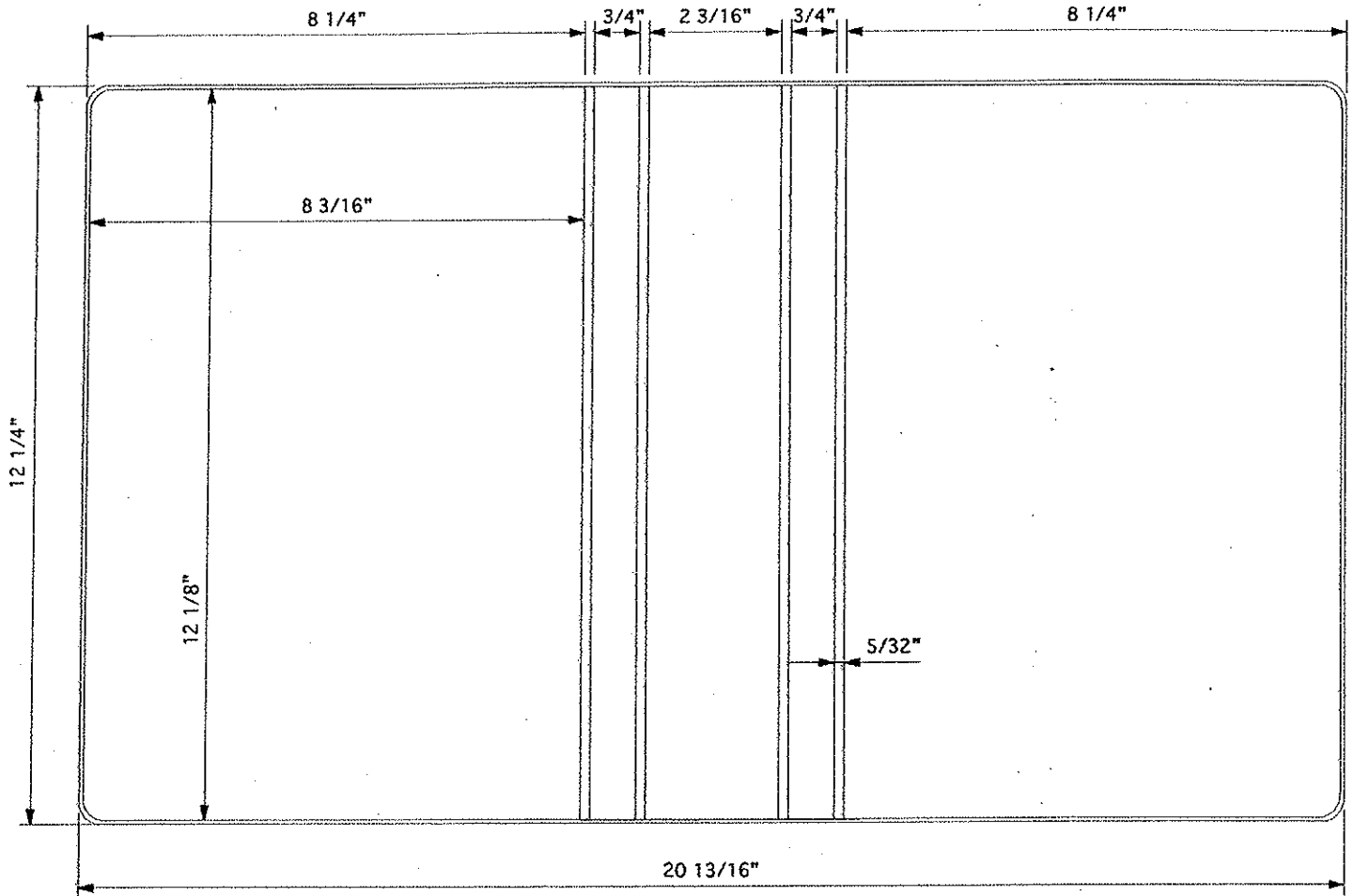

MATERIAL SPECS		GAUGE	PCS.	MATERIAL SPECS		GAUGE	PCS.
COVER MAT.	13 X 21 5/8		1	LINING MAT.	13 X 21 5/8		1
COVER MAT.				LINING MAT.			
DIE CUT				HORZ. PKT.	5 3/8 X 21 5/8		1
COL	12 3/8 X 12		1	VERT. PKT.			
LABEL HOLDER				DIE CUT			
GUSSET				REINF.			
BOARD SPECS		5/16" R. CORNERS		GAUGE	PCS.	BOARD SPECS	
F.C. BOARD	12 1/32 X 8 3/32	120	1	F.C. BOARD			
B.B. BOARD	12 1/32 X 2 3/32	120	1	B.B. BOARD			
B.C. BOARD	12 1/32 X 8 3/32	120	1	B.C. BOARD			
FLAP BD.				DIE CUT			
BOARD	12 1/32 X 21/32	120	2	DIE CUT			

DIE #	8643	METAL	QA CAN VIN POST	RADIUS	3/8"
ORDER #	878921	CUSTOMER	U O P LLC	TEAR SEAL	.014
SHEET SIZE	11 X 17 1/2	STYLE CASE	VINYL QVC BINDER	BAR SEAL	48-4
CAP.	3"	DUE DATE	2-3-09	COMPLETED	
LOCATION		QUANTITY	100	DATE	1-15-09

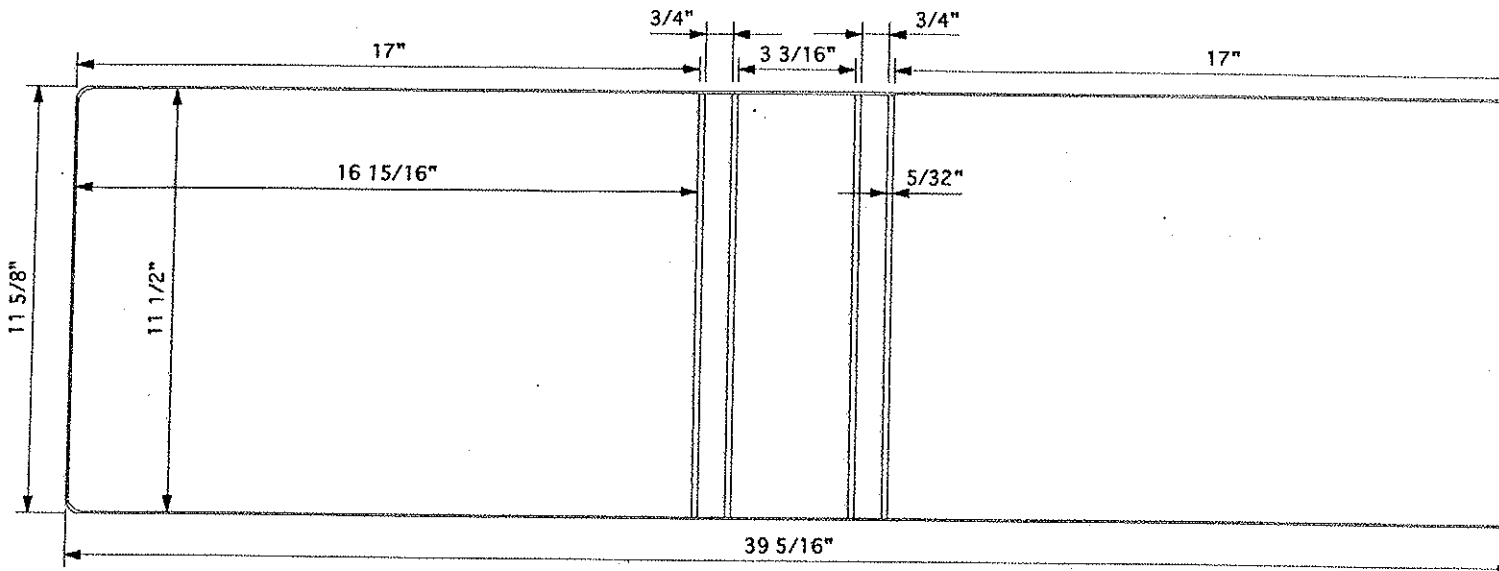

MATERIAL SPECS		GAUGE	PCS.	MATERIAL SPECS		GAUGE	PCS.
COVER MAT.	12 3/8 X 40		1	LINING MAT.	12 3/8 X 40		1
COVER MAT.				LINING MAT.			
DIE CUT				HORZ. PKT.			
COL	11 3/4 X 3 1/2		1	VERT. PKT.			
LABEL HOLDER				DIE CUT			
GUSSET				REINF.			
BOARD SPECS		5/16" R. CORNERS		BOARD SPECS		5/16" R. CORNERS	
F.C. BOARD	11 7/16 X 16 7/8	120	1	F.C. BOARD			
B.B. BOARD	11 7/16 X 3 3/32	120	1	B.B. BOARD			
B.C. BOARD	11 7/16 X 16 7/8	120	1	B.C. BOARD			
FLAP BD.				DIE CUT			
BOARD	11 7/16 X 21/32	120	2	DIE CUT			