

Product Code

Style Case *A.D. VRB*

Sheet Size *10* x *7 1/4* Cap. *1*

Die No. *4411*

Order No. *965277*

Plate

SOUTHERN LIFE & HEALTH

Customer

Metal
Total Vinyl
Quantity
Date
Type Corners
Radius
Completed

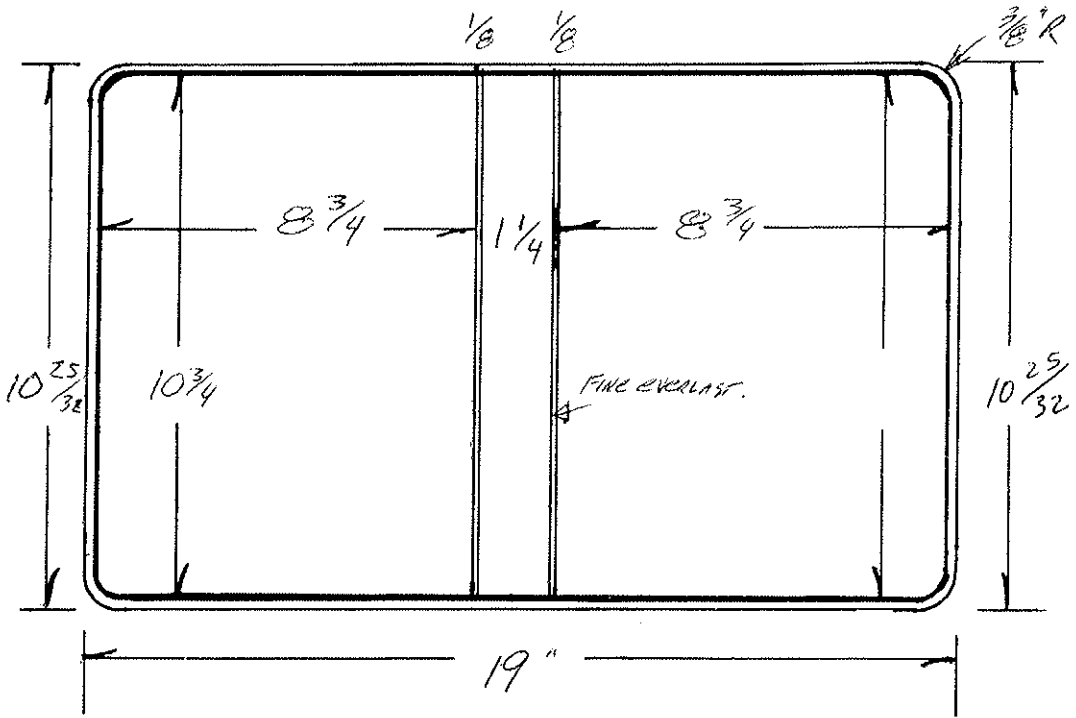

	Gauge	Thick
Tear Seal		
Bar Seal		
Bar Seal		

	No. of Feet
Tear Seal	
Bar Seal	
Bar Seal	

Size - B-line

CHLN - 14V

Code	Ga.	PCS	Cutting Specs		Code	Ga.	Pcs.	Cutting Specs	
			Size	Out				Size	Out
Cover Mat.			<i>11 1/2</i>	<i>19 3/4</i>	Lining Mat.			<i>11 1/2</i>	<i>19 3/4</i>
Cover Mat.			X		Lining Mat.			X	
Vert. Pckt.			X		Horz. Pckt.			X	
Vert. Pckt.			X		Horz. Pckt.			X	
Pocket			X		Pocket			X	
Label Holder			X		Card Holder			X	
Material			X		Material			X	
Material			X		Material			X	
Material			X		Material			X	
F.C. Board			<i>10 21/32</i>	<i>8 21/32</i>	B.C. Board			<i>10 21/32</i>	<i>8 21/32</i>
B.C. Board			X		B.B. Board			<i>10 21/32</i>	<i>1 5/32</i>
Center Board			X		Board			X	
Board			X		Strip			X	
Cover Pad			X		Strip			X	
					B.B. Pad			X	

Product Code

Style Case VRB

Sheet Size 10 X 8

Cap. 1 1/2 Die No. 4647

Order No. 967648

Plate C-10-8

FEDERAL RESERVE BANK

Customer

Metal
Total Vinyl
Quantity <u>500</u>
Date <u>1-28-91</u>
Type Corners
Radius <u>3/8"</u>
Completed

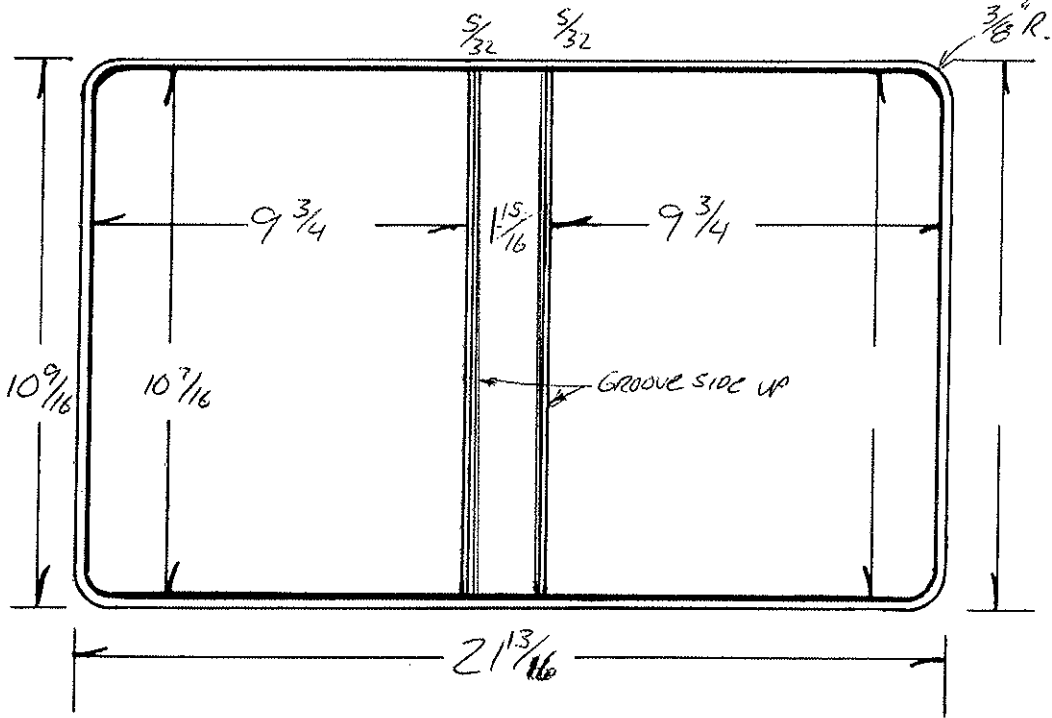

	Gauge	Thick
Tear Seal	<u>.014</u>	<u>1/16</u>
Bar Seal	<u>.4254</u>	<u>5/32</u>
Bar Seal		

	No. of Feet
Tear Seal	
Bar Seal	
Bar Seal	

SIZE - BaPace
 CHECK YAV

SIZE PER SAMPLE

Code	Ga.	Pcs	Cutting Specs		Code	Ga.	Pcs	Cutting Specs			
			Size	Out				Size	Out		
Cover Mat.			$11 \frac{3}{8} X 22 \frac{5}{8}$	<u>15</u>	<u>1</u>	Lining Mat.			$11 \frac{3}{8} X 22 \frac{5}{8}$	<u>15</u>	<u>1</u>
Cover Mat.			X			Lining Mat.			X		
Vert. Pckt.			X			Horz. Pckt.			X		
Vert. Pckt.			X			Horz. Pckt.			X		
Pocket			X			Pocket			X		
Label Holder			X			Card Holder			X		
Material			X			Material			X		
Material			X			Material			X		
Material			X			Material			X		
F.C. Board			$10 \frac{1}{32} X 9 \frac{21}{32}$	<u>100</u>	<u>1</u>	B.C. Board			X		
B.C. Board			$10 \frac{1}{32} X 9 \frac{21}{32}$	<u>100</u>	<u>1</u>	B.B. Board			$10 \frac{1}{32} X 1 \frac{27}{32}$	<u>100</u>	<u>1</u>
Center Board			X			Board			X		
Board			X			Strip			X		
Cover Pad			X			Strip			X		
						B.B. Pad			X		

Product Code

Style Case *VRB 9 1/2-3-1 N.B. METAL*

Sheet Size *10 x 7 1/2* Cap. *1*

Die No. *4676*

Order No. *968044*

Plate *P2-7*

Customer

COLAO GROUP

Metal
Total Vinyl
Quantity <i>12,000</i>
Date <i>3-5-91</i>
Type Corners
Radius <i>3/8"</i>
Completed

SEE DWG.

	Gauge	Thick
Tear Seal	<i>NAT</i>	<i>1/8</i>
Bar Seal		
Bar Seal		

	No. of Feet
Tear Seal	
Bar Seal	
Bar Seal	

SIZE - B. PAGE
CHECK - (2)

MADE BY: ABLE DIE CO.

SIZES FROM ORDER ONLY FROM J.W.

Code	Ga.	PCS	Cutting Specs		Code	Ga.	Pcs.	Cutting Specs	
			Size	Out				Size	Out
Cover Mat.		<i>12</i>	<i>1</i>		Lining Mat.		<i>12</i>	<i>1</i>	
	<i>11 3/8 x 19 3/4</i>					<i>11 3/8 x 19 3/4</i>			
Cover Mat	X				Lining Mat.	X			
Vert. Pckt.	X				Horz. Pckt.	X			
Vert. Pckt.	X				Horz. Pckt.	<i>4 3/8 x 9 1/8</i>	<i>12</i>	<i>1</i>	
Pocket	X				Pocket	X			
Label Holder	X				Card Holder	X			
Material	<i>COL. 10 3/4 x 19 3/4</i>	<i>8</i>	<i>1</i>		Material	X			
Material	X				Material	X			
Material	X				Material	X			
F.C. Board	<i>10 1/2 x 8 1/2</i>	<i>100</i>	<i>1</i>		B.C. Board	X			
B.C. Board	<i>10 1/2 x 8 1/2</i>	<i>100</i>	<i>1</i>		B.B. Board	<i>10 1/2 x 1 1/32</i>	<i>100</i>	<i>1</i>	
Center Board	X				Board	X			
Board	X				Strip	X			
Cover Pad	X				Strip	X			
					B.B. Pad	X			

Product Code

Style Case *URB low 9 1/2 - 3 1/2 NB*

Sheet Size *10* X *8*

Cap. *1/2*

Die No. *4894*

Order No. *970296*

Plate *C-19-8*

Customer

AMERICAN COPY

10-23

Metal
Total Vinyl
Quantity <i>400</i>
Date <i>10-9-91</i>
Type Corners
Radius <i>3/8</i>
Completed

	Gauge	Thick
Tear Seal	<i>.012</i>	<i>1/16</i>
Bar Seal	<i>#48-4</i>	<i>1/32</i>
Bar Seal		

	No. of Feet
Tear Seal	
Bar Seal	
Bar Seal	

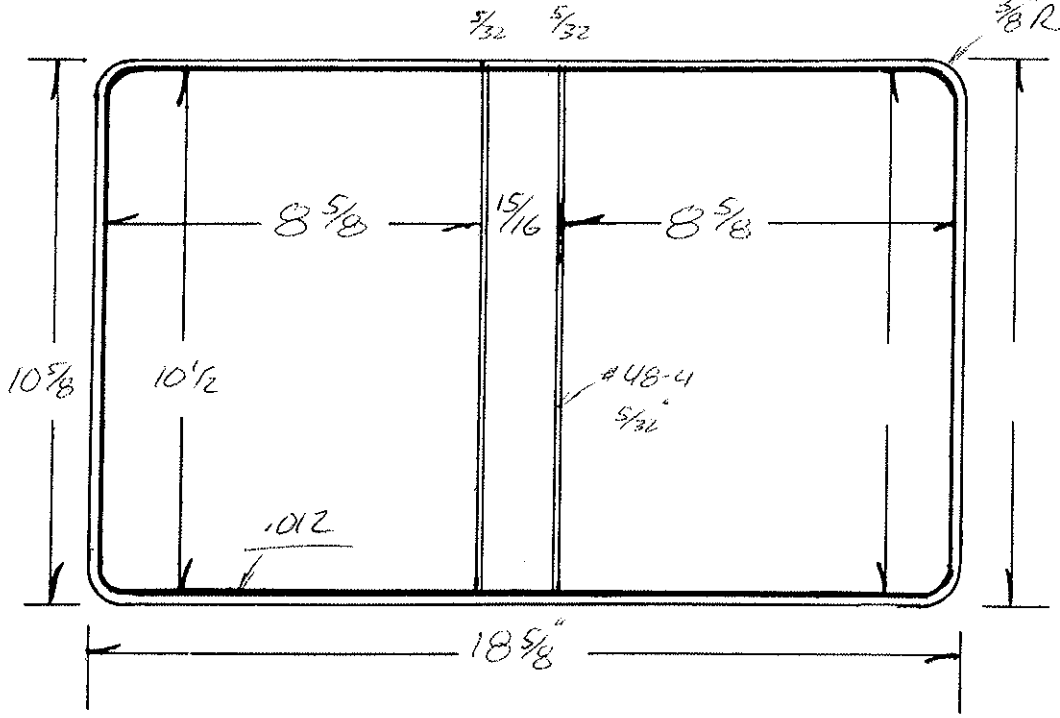

DWG - B. Pace
CHECK
KAV

Code	Ga.	PCS	Cutting Specs.		Code	Ga.	Pcs.	Cutting Specs.	
			Size	Out				Size	Out
Cover Mat.		<i>12</i>	<i>1</i>		Lining Mat.		<i>12</i>	<i>1</i>	
Cover Mat.					Lining Mat.				
Vert. Pckt.					Horz. Pckt.				
Vert. Pckt.					Horz. Pckt.				
Pocket					Pocket				
Label Holder					Card Holder				
Material <i>FULL COL</i>	<i>10 3/4</i>	<i>8</i>	<i>1</i>		Material				
Material					Material				
Material					Material				
F.C. Board	<i>10 7/16</i>	<i>100</i>	<i>1</i>		B.C. Board				
B.C. Board	<i>10 7/16</i>	<i>100</i>	<i>1</i>		B.B. Board	<i>10 7/16</i>	<i>100</i>	<i>1</i>	
Center Board					Board				
Board					Strip				
Cover Pad					Strip				
					B.B. Pad				

DIE #	5308	STYLE CASE	VRB	LOCATION	D18-2
SHEET SIZE	10 1/2 x 7 1/2 + 1/2	CAP.	1/2	ORDER NO.	974743.1
CUSTOMER	Resort Publications			DUE DATE	

QUANTITY	325
DATE	3-24-93

RADIUS	3/8
COMPLETED	

TEAR SEAL	.014
BAR SEAL	484

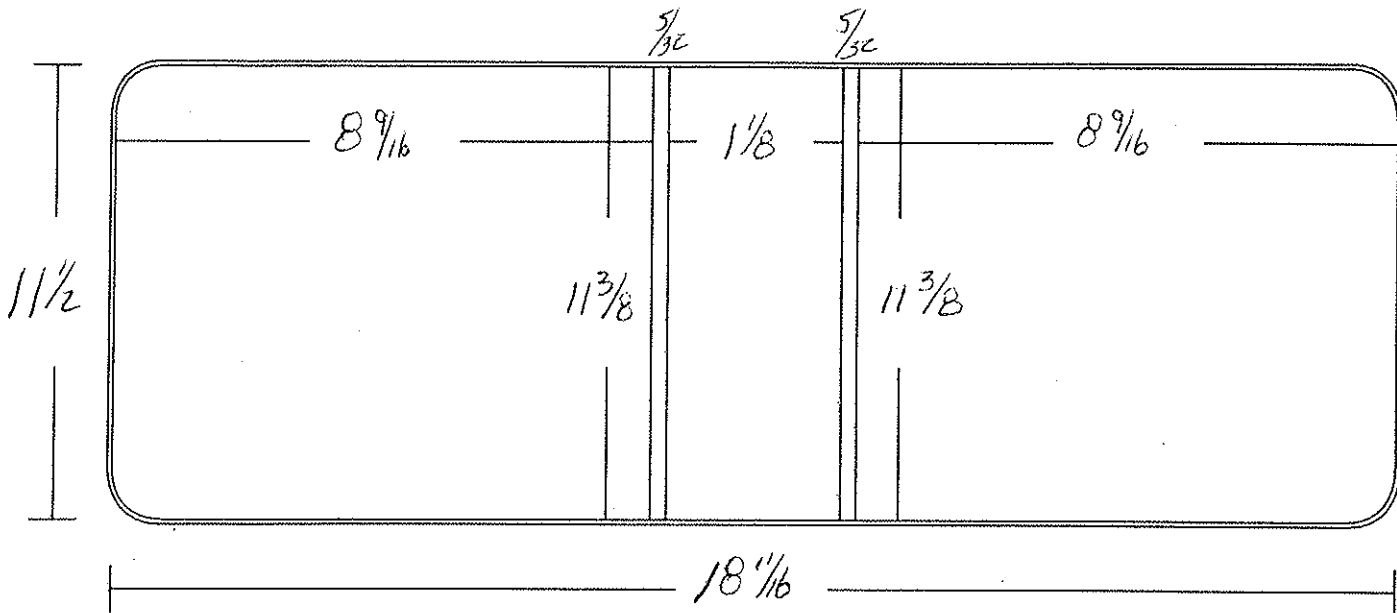

MATERIAL

	CODE		GA	PCS		CODE		GA	PCS
COVER MATL		12 1/4 X 19 7/16		1	LINING		12 1/4 X 19 7/16		1
COVER MATL		X			LINING		X		
VERT PKT		X			HORZ PKT		X		
VERT PKT		X			HORZ PKT		X		
CARD HOLDER		X			DIAGONAL PKT		X		
COL		X			LABEL HOLDER		X		
EX. COL		X			GUSSET		X		
		X			REINF.		X		
		X					X		

PRINTS

FRONT COVER	X	BACK BONE	X	BACK COVER	X
-------------	---	-----------	---	------------	---

BOARDS

	CODE		PT	PCS		CODE		PT	PCS
F.C. BOARD		11 5/16 X 8 1/2	100	1	F.C. BOARD		11 9/32 X 8 15/32	120	1
B.B. BOARD		11 5/16 X 1 1/32	100	1	B.B. BOARD		11 9/32 X 1 1/32	120	1
B.C. BOARD		11 5/16 X 8 1/2	100	1	B.C. BOARD		11 9/32 X 8 15/32	120	1
B. UP STRIP		X					X		
		X					X		

NB Straight D

DIE # 5525		STYLE CASE VINYL RING BINDER			LOCATION	
SHEET SIZE 10 X 7 1/2 + 1/2		CAP. 1 1/2		ORDER # 977450		
CUSTOMER TEXTRON				DUE DATE		
QUANTITY	10000	RADIUS	3/8	TEAR SEAL	.012	
DATE		COMPLETED		BAR SEAL	484	

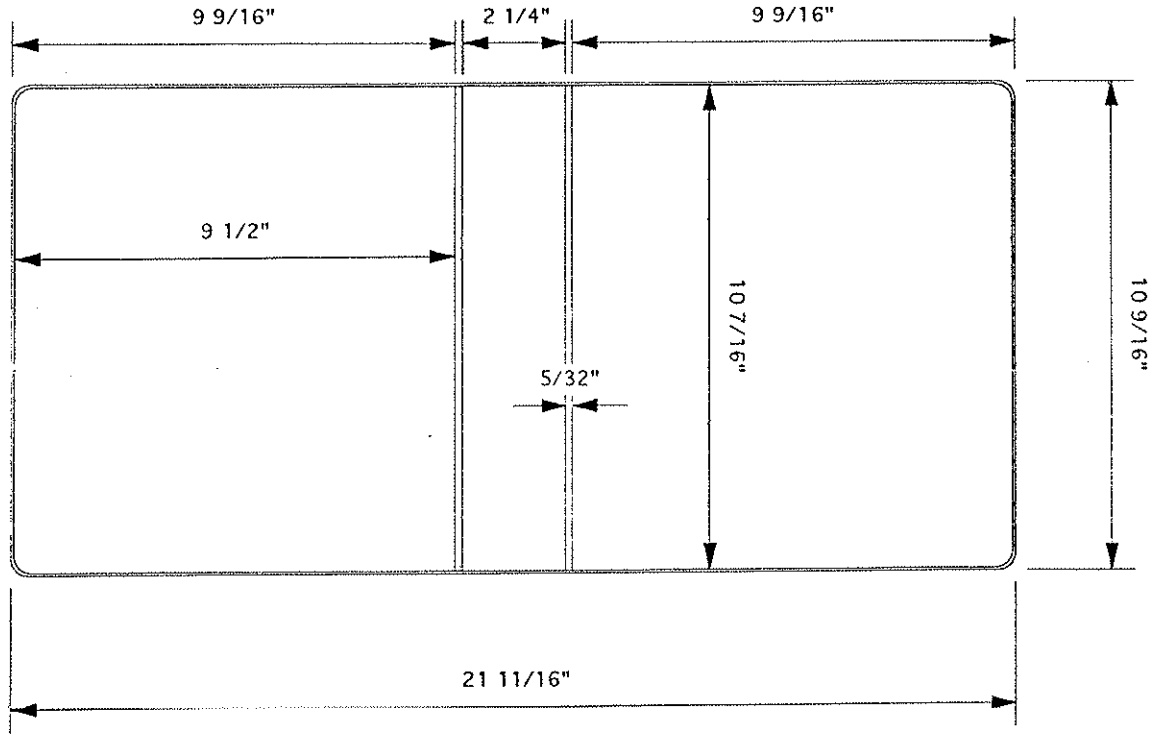

MATERIAL SPECS		GA		PCS		GA		PCS	
COVER MATL	11 5/16 X 22 7/16	1	LINING	11 5/16 X 22 7/16	1				
COVER MATL			LINING						
VERT PKT			HORZ PKT						
VERT PKT			HORZPKT						
CARD HOLDER			DIAGONAL PKT						
COL			LABEL HOLDER						
EX COL			GUSSETT						
			REINF						

BOARD SPECS					
F.C. BOARD	10 3/8 x 9 7/16	100	1	F.C. BOARD	
B.B. BOARD	10 3/8 x 2 5/32	100	1	B.B. BOARD	
B.C. BOARD	10 3/8 x 9 7/16	100	1	B.C. BOARD	
BU STRIP					

DIE #	6004	METAL	9 1/2" RR NB	RADIUS	1/4"
ORDER #	983855	CUSTOMER	OLAN MILLS	TEAR SEAL	.014
SHEET SIZE	10 X 8 1/2	STYLE CASE	VINYL RING BINDER	BAR SEAL	253
CAP.	1"	DUE DATE	2-20-96	COMPLETED	
LOCATION	F-2-2	QUANTITY	1	DATE	2-15-96

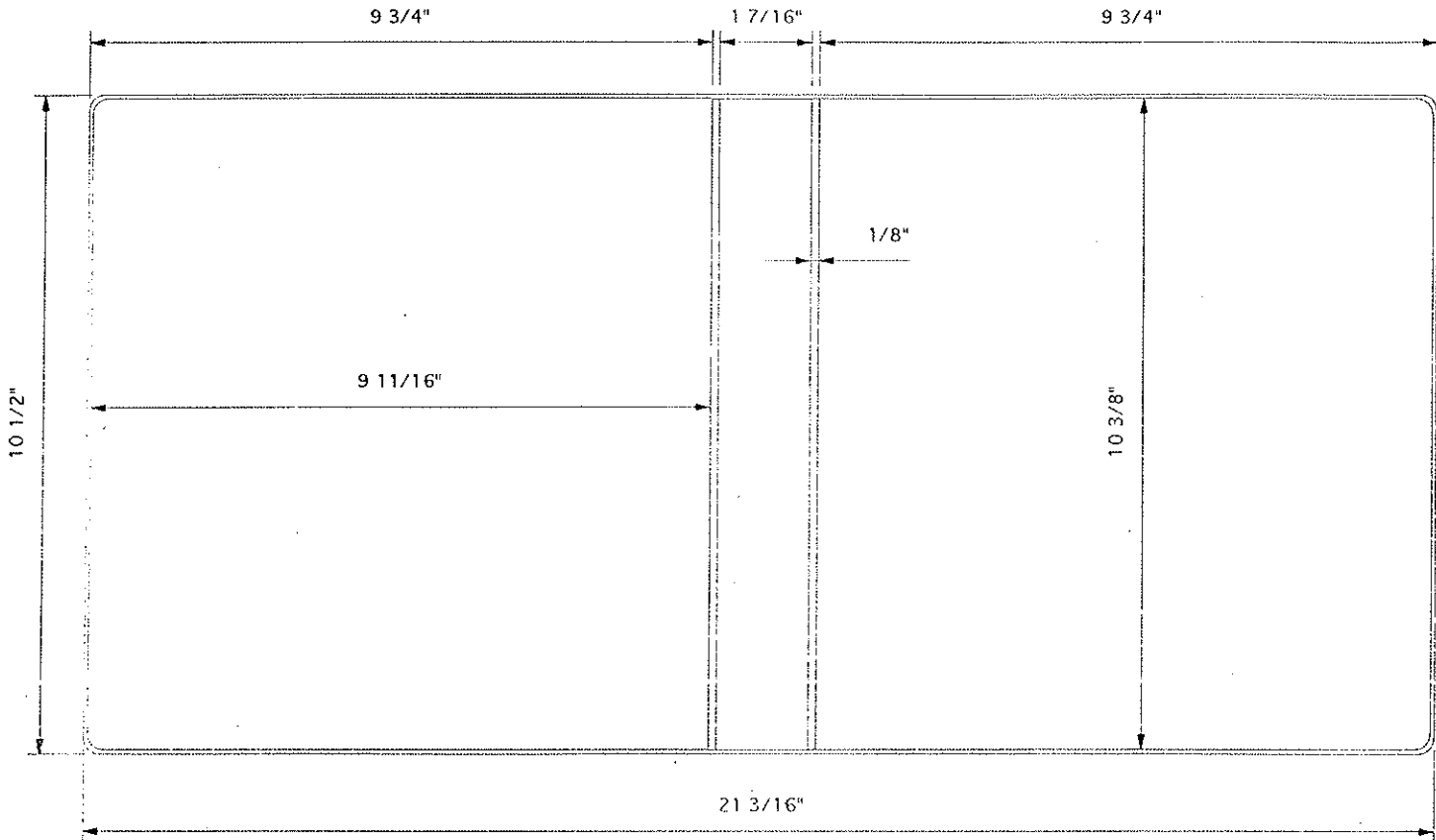

MATERIAL SPECS		GAUGE		PCS.		MATERIAL SPECS		GAUGE		PCS.	
COVER MAT.	11 1/4 X 22					LINING MAT.	11 1/4 X 22				1
COVER MAT.						LINING MAT.					
DIE CUT						HORZ. PKT.					
COL						VERT. PKT.					
LABEL HOLDER						DIE CUT					
GUSSET						REINF.					

BOARD SPECS		GAUGE		PCS.		BOARD SPECS		GAUGE		PCS.	
F.C. BOARD	10 5/16 X 9 5/8	48	1	F.C. BOARD							
B.B. BOARD	10 5/16 X 1 11/32	100	1	B.B. BOARD							
B.C. BOARD	10 5/16 X 9 5/8	48	1	B.C. BOARD	DIE CUT - 6004 A						
B.U. STRIP				DIE CUT	13 1/8 X 20 1/16						
DIE CUT				DIE CUT							

DIE #	6330	METAL	4" ANGLE D	RADIUS	3/8"
ORDER #	988083	CUSTOMER	LITHO INDUSTRIES	TEAR SEAL	.014
SHEET SIZE	11 X 11	STYLE CASE	VINYL RING BINDER	BAR SEAL	254
CAP.	4"	DUE DATE	9-30-97	COMPLETED	
LOCATION	M-1-2	QUANTITY	225	DATE	9-22-97

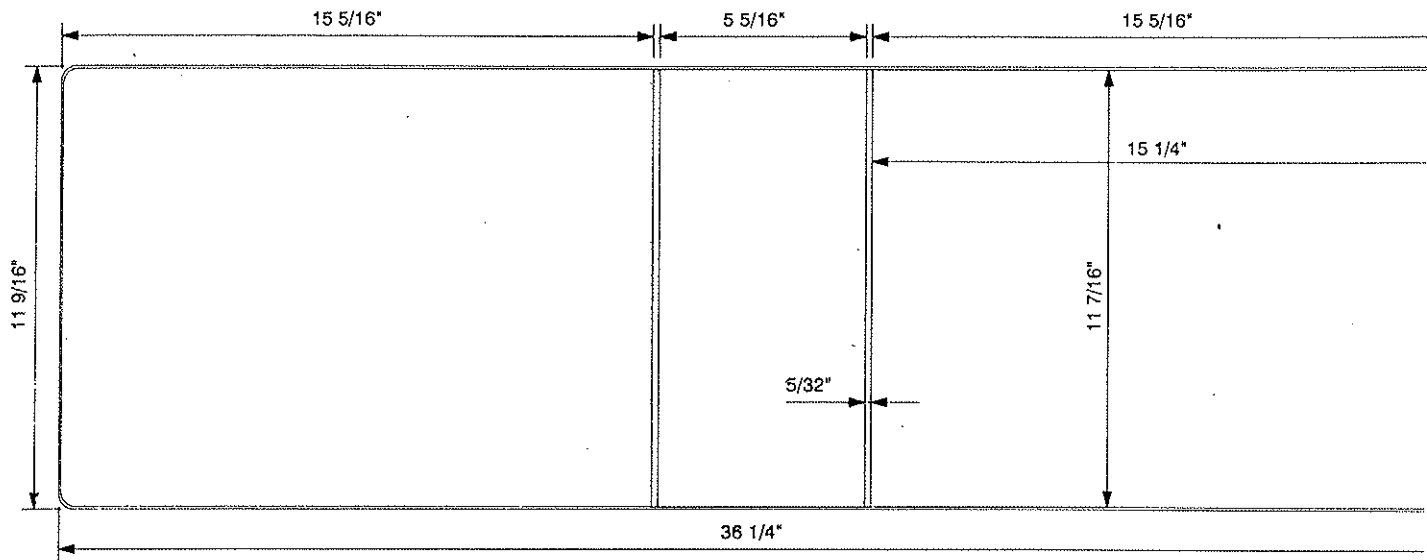

MATERIAL SPECS		GAUGE		PGS.		MATERIAL SPECS		GAUGE	
COVER MAT.	12 5/16 X 37			1		LINING MAT.	12 5/16 X 37		
COVER MAT.						LINING MAT.			
DIE CUT						HORZ. PKT.	5 3/8 X 37		
COL	11 11/16 X 37			1		VERT. PKT.			
LABEL HOLDER						DIE CUT			
GUSSET						REINF.			

BOARD SPECS		GAUGE		PGS.		BOARD SPECS		GAUGE	
F.C. BOARD	11 11/32 X 15 5/32	120	1	1		F.C. BOARD			
B.B. BOARD	11 11/32 X 5 7/32	120	1	1		B.B. BOARD			
B.C. BOARD	11 11/32 X 15 5/32	120	1	1		B.C. BOARD			
FLAP BD.						DIE CUT			
BOARD						DIE CUT			

DIE #	7044	METAL	TMPI METAL	RADIUS	3/8
ORDER #	398178	CUSTOMER	EMBASSY SUITES	TEAR SEAL	.012
SHEET SIZE	10 3/4 X 8 3/4	STYLE CASE	VINYL BINDER	BAR SEAL	48-3
CAP.	1 3/8"	DUE DATE	1-16-01	COMPLETED	
LOCATION		QUANTITY	50	DATE	1-5-01

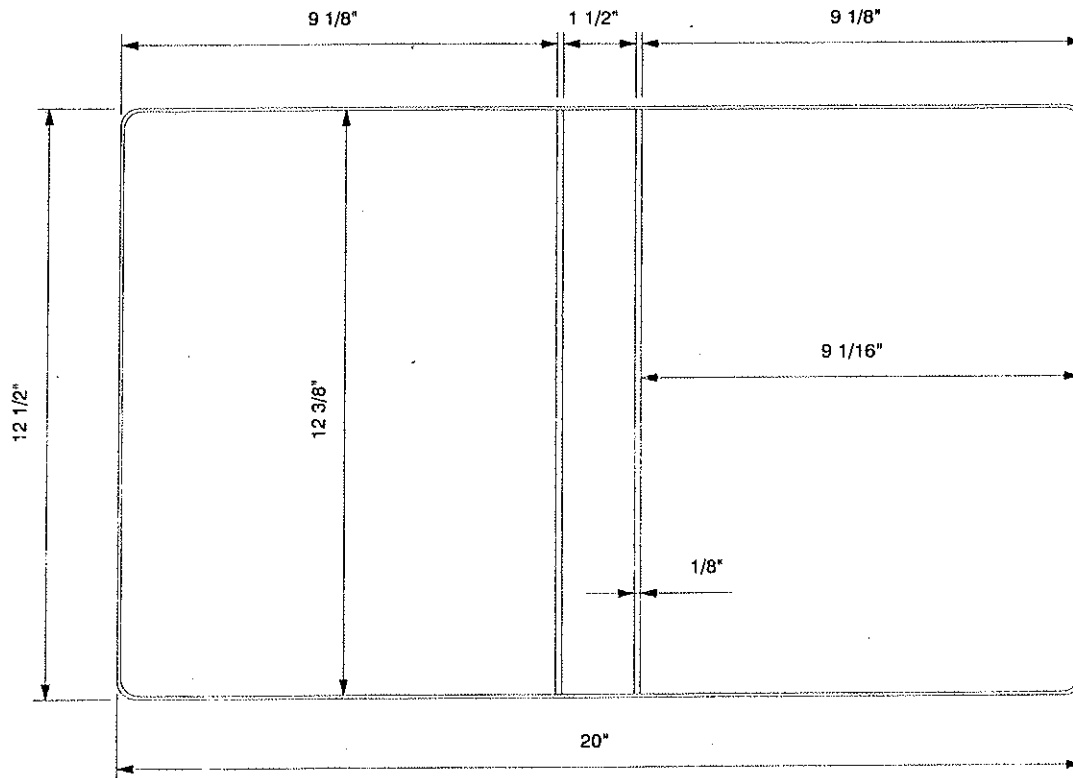

MATERIAL SPECS		GAUGE		MATERIAL SPECS		GAUGE	
COVER MAT.	13 1/4 X 20 3/4		1	LINING MAT.	13 1/4 X 20 3/4		1
COVER MAT.				LINING MAT.			
DIE CUT				HORZ. PKT.			
COL				VERT. PKT.			
LABEL HOLDER				DIE CUT			
GUSSET				REINF.			

BOARD SPECS		GAUGE		BOARD SPECS		GAUGE	
F.C. BOARD	12 5/16 X 9	100	1	F.C. BOARD			
B.B. BOARD	12 5/16 X 1 13/32	100	1	B.B. BOARD			
B.C. BOARD	12 5/16 X 9	100	1	B.C. BOARD			
FLAP BD.				DIE CUT			
BOARD				DIE CUT			

DIE # 8644
 ORDER # 878788
 SHEET SIZE 10 X 8 1/2
 CAP. 1/2"
 LOCATION

METAL
 CUSTOMER 9 1/2" RR W/B
 OLAN MILLS
 STYLE CASE VINYL BINDER
 DUE DATE 2-2-09
 QUANTITY 374

RADIUS 3/8"
 TEAN SEAL .014
 BAR SEAL 254 SMOOTH
 COMPLETED
 DATE 1-16-09

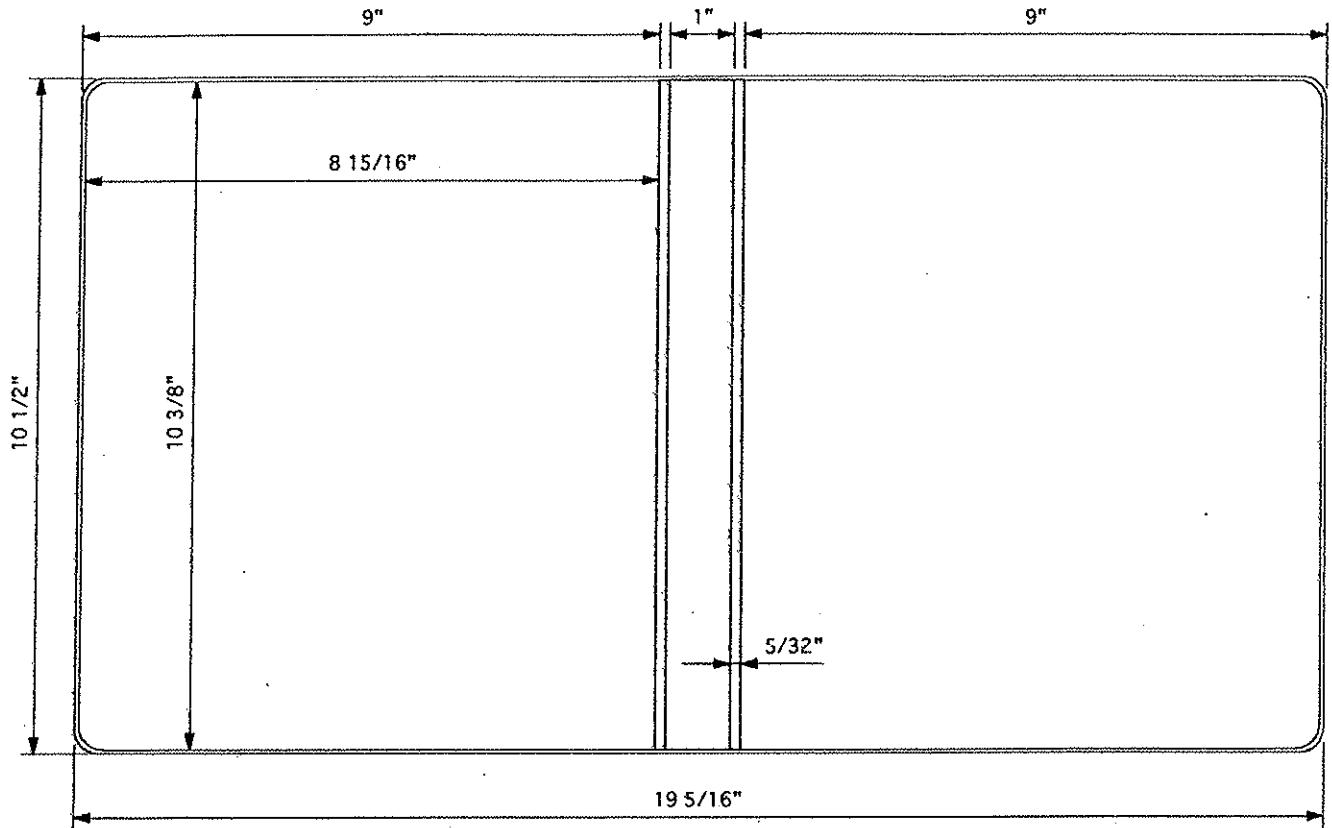

QUANTITY	MATERIAL SPEC	QUANTITY	MATERIAL SPEC
1	COVER MAT. 11 1/4 X 20 1/16	1	LINING MAT. 11 1/4 X 20 1/16
1	COVER MAT.	1	LINING MAT.
1	DIE CUT	1	HORZ. PKT.
1	COL.	1	VERT. PKT.
1	LABEL HOLDER	1	DIE CUT
1	GUSSET	1	REINF.
QUANTITY	BOARD SPEC	QUANTITY	BOARD SPEC
1	F.C. BOARD 10 9/32 X 8 27/32	1	F.C. BOARD
1	B.B. BOARD 10 9/32 X 29/32	1	B.B. BOARD
1	B.C. BOARD 10 9/32 X 8 27/32	1	B.C. BOARD
1	FLAP BD. BOARD	1	DIE CUT 12 11/16 X 19 3/16
1	BOARD	1	DIE CUT

8644-A
 PADDED 1

DIE #	8704	METAL	RR W/B	RADIUS	3/8"
ORDER #	894753	CUSTOMER	UNITED METHODIST PUB.	TEAR SEAL	.014
SHEET SIZE	10 1/2 X 11	STYLE CASE	VINYL BINDER	BAR SEAL	48-4
CAP.	1"	DUE DATE	5-29-09	COMPLETED	
LOCATION		QUANTITY	300	DATE	5-27-09

*** WARNING DRAWING NOT ACTUAL SIZE ***

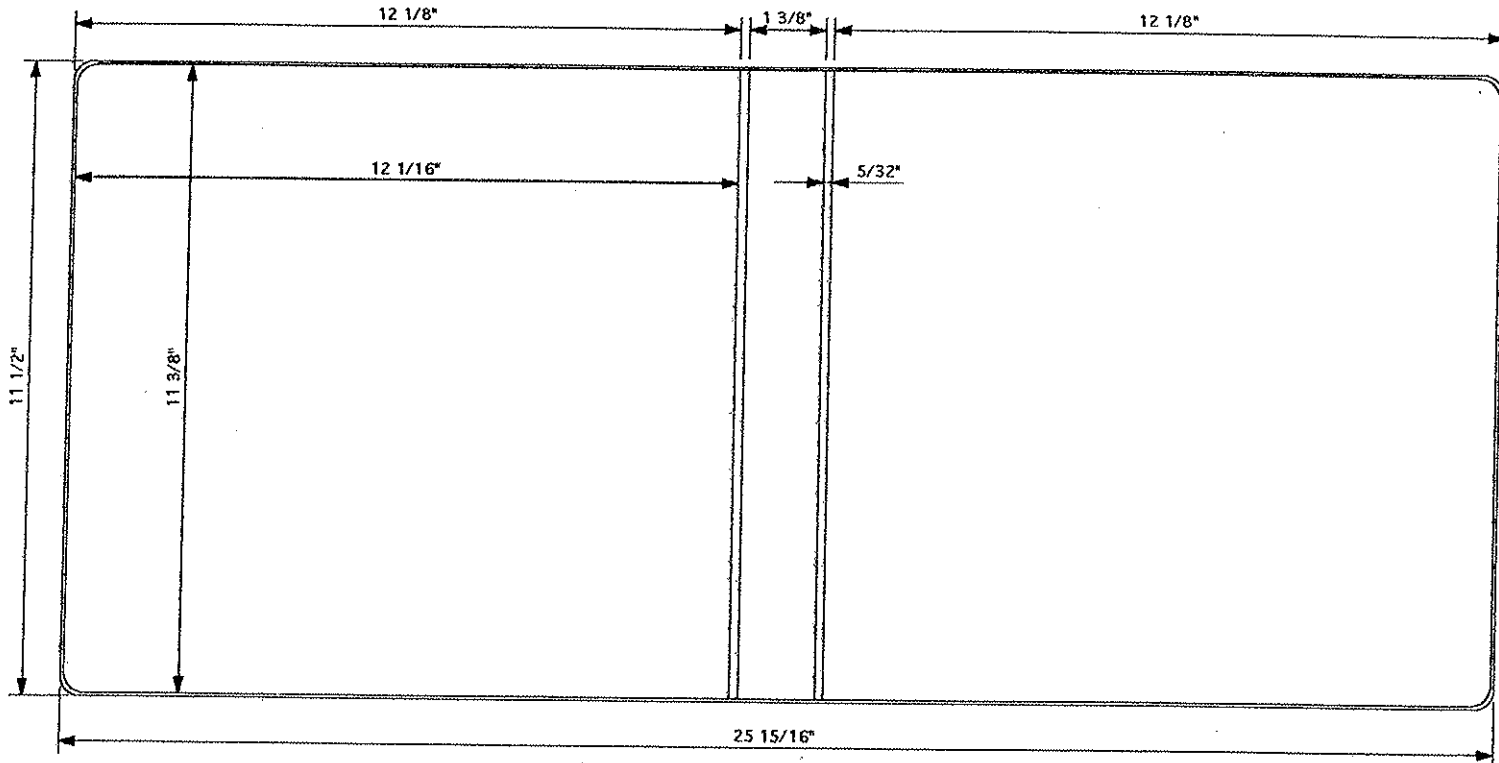

MATERIAL SPECS		GAUGE	PCS.	MATERIAL SPECS	GAUGE	PCS.
COVER MAT.	12 1/4 X 26 3/4		1	LINING MAT.	12 1/4 X 26 3/4	1
COVER MAT.				LINING MAT.		
DIE CUT				HORZ. PKT.		
COL				VERT. PKT.		
LABEL HOLDER				DIE CUT		
GUSSET				REINF.		
BOARD SPECS		GAUGE	PCS.	BOARD SPECS	GAUGE	PCS.
F.C. BOARD	11 5/16 X 12	120	1	F.C. BOARD		
B.B. BOARD	11 5/16 X 1 9/32	120	1	B.B. BOARD		
B.C. BOARD	11 5/16 X 12	120	1	B.C. BOARD		
FLAP BD.				DIE CUT		
BOARD				DIE CUT		