

Product Code

Style Case *H.S Vinyl Binder*

Sheet Size *11 X 9*

Cap. *1*

Die No. *7232*

Order No. *36358-0*

Plate

Customer *w/ fastener*

Southeastern Printing

Material	
Total Vinyl	<i>.044</i>
Quantity	<i>200</i>
Date	<i>12-8-78</i>
Type Corners	<i>RD</i>
Radius	<i>1/4</i>
Completed	

	Gauge	Thick
Bar Seal	<i>.020</i>	<i>3/32</i>
Bar Seal	<i>102</i>	<i>3/32</i>
Bar Seal		

	No. of Feet
Bar Seal	<i>5 1/2</i>
Bar Seal	<i>2</i>
Bar Seal	

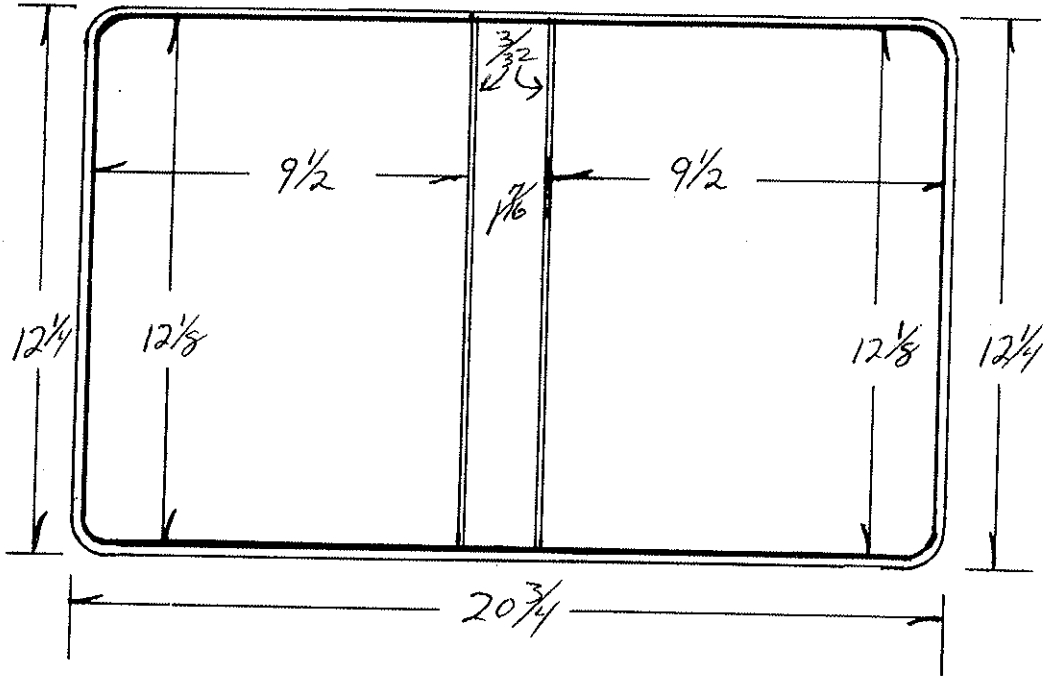

Code	Ga.	#	Cutting Specs		Code	Ga.	#	Cutting Specs	
			Size	Out				Size	Out
Cover Mat.		<i>13</i>	<i>X</i>	<i>2 13/8</i>		<i>1</i>			
Cover Mat.			<i>X</i>		Lining Mat.		<i>13</i>	<i>X</i>	<i>2 13/8</i>
Int. Pckt.		<i>12 1/8</i>	<i>X</i>	<i>9 5/8</i>	Int. Pckt.			<i>X</i>	
Int. Pckt.			<i>X</i>		Horz. Pckt.			<i>X</i>	
Pocket			<i>X</i>		Horz. Pckt.			<i>X</i>	
Card Holder			<i>X</i>		Pocket			<i>X</i>	
Material			<i>X</i>		Card Holder			<i>X</i>	
Material			<i>X</i>		Material			<i>X</i>	
Material			<i>X</i>		Material			<i>X</i>	
Material			<i>X</i>		Material			<i>X</i>	
B.C. Board		<i>12 1/32</i>	<i>X</i>	<i>9 13/32</i>	B.C. Board		<i>1</i>		
B.C. Board			<i>X</i>		B.C. Board		<i>12 1/32</i>	<i>X</i>	<i>9 13/32</i>
Board			<i>X</i>		B.B. Board		<i>1</i>		
Board			<i>X</i>		B.B. Board		<i>12 1/32</i>	<i>X</i>	<i>1 1/32</i>
Board			<i>X</i>		Board			<i>X</i>	
Strip			<i>X</i>		Strip			<i>X</i>	
Strip			<i>X</i>		Strip			<i>X</i>	
B.B. Pad			<i>X</i>		B.B. Pad			<i>X</i>	

Product Code

Style Case *6 Ring Protector (Mem)*

Sheet Size *11 X 9* Cap. *1/2* Die No. *2029* Order No. *31946-7* Plate

Customer

Richard Northam Ltd.

Metal
Total Vinyl
Quantity <i>1000</i>
Date <i>11-4-77</i>
Type Corners <i>Revised</i>
Radius <i>1/4</i>
Completed

	Gauge	Thick
Tear Seal	<i>20</i>	<i>3/32</i>
Bar Seal		<i>3/32</i>
Bar Seal		

	No. of Feet
Tear Seal	<i>6</i>
Bar Seal	<i>2</i>
Bar Seal	

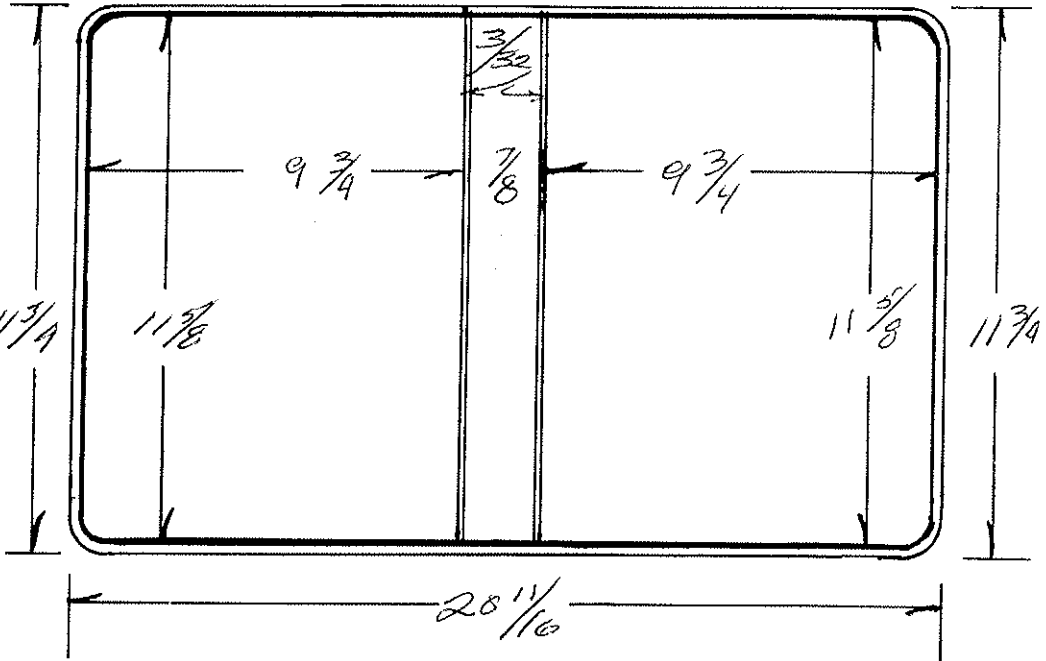

Code	Ga.	#	Cutting Specs		Code	Ga.	#	Cutting Specs	
			Size	Out				Size	Out
Cover Mat.			<i>12 3/8 X 21 1/16</i>	<i>1</i>	Lining Mat.			<i>12 3/8 X 21 1/16</i>	<i>1</i>
Cover Mat.			<i>12 3/8 X 21 1/16</i>	<i>1</i>	Lining Mat.			X	
Vert. Pckt.			X		Horz. Pckt.			<i>5 3/8 X 10 1/2</i>	<i>1</i>
Vert. Pckt.			X		Horz. Pckt.			<i>5 3/8 X 21 7/16</i>	
Pocket			X		Pocket			X	
Label Holder			X		Card Holder			X	
Material			X		Material			X	
Material			X		Material			X	
Material			X		Material			X	
F.C. Board			X		B.C. Board			<i>11 1/32 X 9 25/32</i>	<i>1</i>
B.C. Board			<i>11 1/32 X 9 25/32</i>	<i>1</i>	B.B. Board			<i>11 1/32 X 25/32</i>	<i>1</i>
Center Board			X		Board			X	
Board			X		Strip			X	
Cover Pad			X		Strip			X	
					B.B. Pad			X	

Product Code

Style Case Ring binder / w Die cut Window

Sheet Size 11 X 9

Cap. 1 1/4

Die No. 2699

Order No. 16014-3

Plate

Baroid Petroleum Services

Customer	
Material	
Material Vinyl	1030
Quantity	300
Notes	
Pre Corners	R.D.
Radius	1/4 & 3/32
Completed	

	Gauge	Thick
Bar Seal	.016	3/32
Front Seal	175	3/16
Rear Seal		

	No. of Feet
Bar Seal	
Front Seal	
Rear Seal	

Window die # 2699

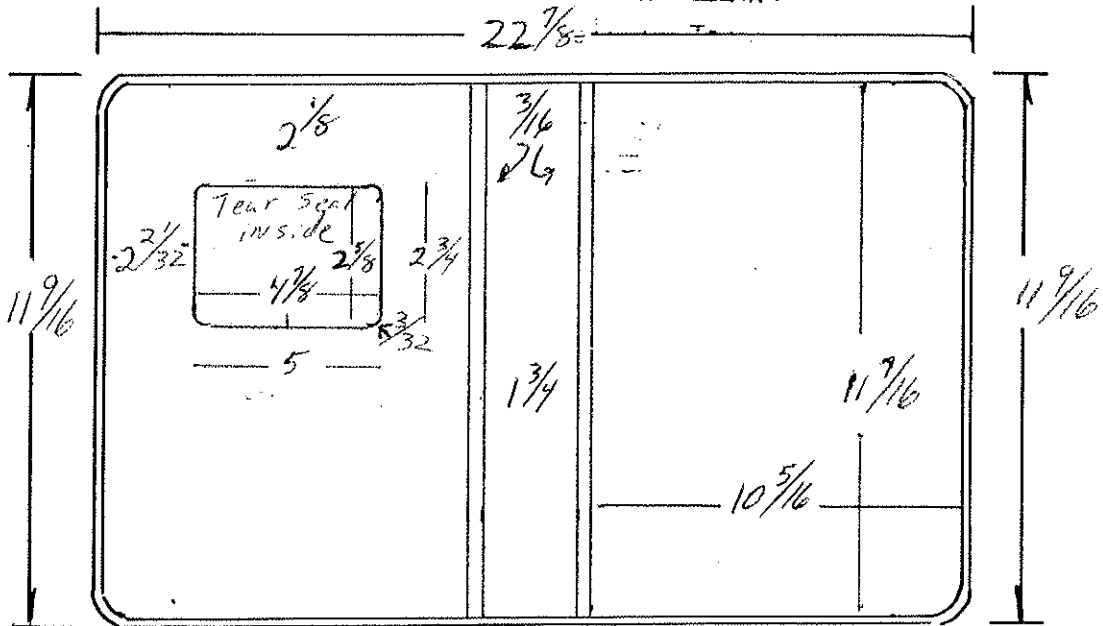

Code	Ga.	#	Cutting Specs		Code	Ga.	#	Cutting Specs	
			Size	Out				Size	Out
Cover Mat.			12 3/16 X	23 5/8	Lining Mat.			12 3/16 X	23 5/8
Cover Mat.			X		Lining Mat.			X	
Front Pckt.			X		Horz. Pckt.			X	
Front Pckt.			X		Horz. Pckt.			X	
Pocket			X		Pocket			X	
Panel Holder			X		Card Holder			X	
Material			X		Material			X	
Material			X		Material			X	
Material			X		Material			X	
B.C. Board			11 1/32 X	10 7/32	B.C. Board			11 1/32 X	10 7/32
B.C. Board			X		B.B. Board			11 1/32 X	1 3/32
Back Board			X		Board			X	
Card			X		Strip			X	
Cover Pad			X		Strip			X	
					B.B. Pad			X	

Product Code

Style Case Ring binder

OVER 211 11 3/4 X 11

Sheet Size 11 X 8 1/2 Cap. 1 1/2 Die No. 2714 Order No. 16265-1 Plate

Customer

Stamm Advertising

Metal
Total Vinyl <u>1030</u>
Quantity <u>75</u>
Date <u>9-29-81</u>
Type Corners <u>Rd.</u>
Radius <u>1/4</u>
Completed

	Gauge	Thick
Tear Seal	<u>.016</u>	<u>7/32</u>
Bar Seal	<u>178</u>	<u>3/16</u>
Bar Seal		

	No. of Feet
Tear Seal	
Bar Seal	
Bar Seal	

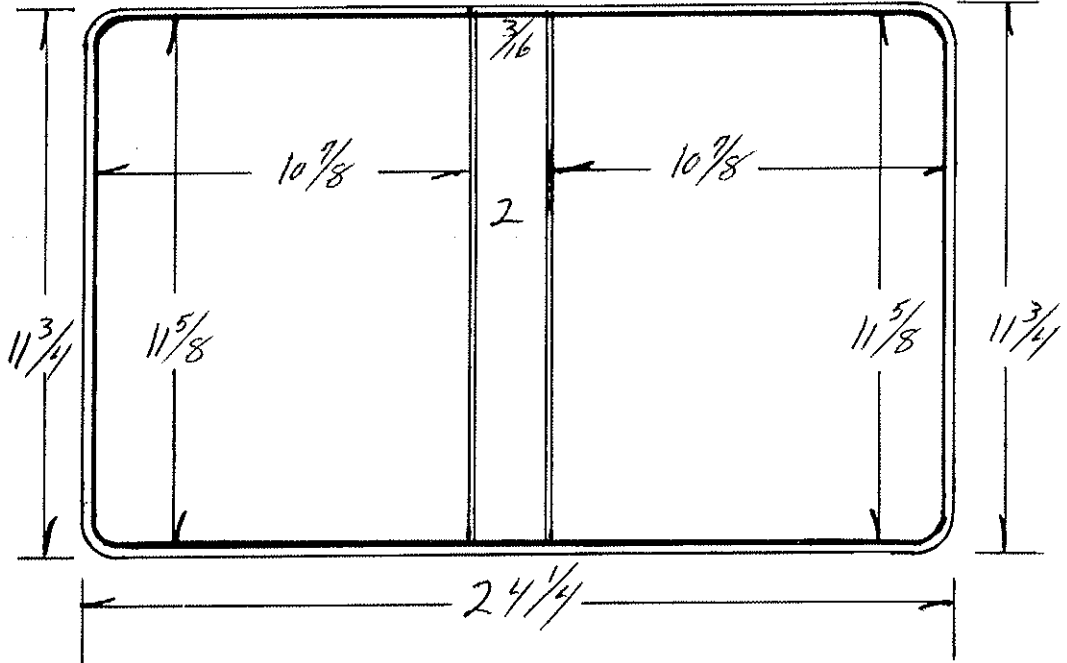

Code	Cutting Specs				Code	Cutting Specs			
	Ga.	Pcs	Size	Out		Ga.	Pcs	Size	Out
Cover Mat.			<u>12 3/8 X 25</u>		Lining Mat.			<u>12 3/8 X 25</u>	
Cover Mat.			X		Lining Mat.			X	
Vert. Pckt.			X		Horz. Pckt.			<u>5 3/8 X 11 3/8</u>	
Vert. Pckt.			X		Horz. Pckt.			<u>5 3/8 X 25</u>	
Pocket			X		Pocket			X	
Label Holder			X		Card Holder			X	
Material			X		Material			X	
Material			X		Material			X	
Material			X		Material			X	
F.C. Board			<u>11 1/32 X 10 25/32</u>		B.C. Board			<u>11 1/32 X 10 25/32</u>	<u>1</u>
B.C. Board			X		B.B. Board			<u>11 1/32 X 1 3/32</u>	<u>1</u>
Center Board			X		Board			X	
Board			X		Strip			X	
Cover Pad			X		Strip			X	
					B.B. Pad			X	

Product Code

Style Case *Ring Binder*

Sheet Size *AS Diagram for Size* 11 X 9

Cap. *1/2* Die No. *2728* Order No. *16617-3* Plate

Customer

Hewlett Packard

Metal
Total Vinyl <i>.030</i>
Quantity <i>2000</i>
Date <i>11-16-81</i>
Type Corners <i>Rd.</i>
Radius <i>1/4</i>
Completed

	Gauge	Thick
Tear Seal	<i>.016</i>	<i>3/32</i>
Bar Seal	<i>178</i>	<i>3/16</i>
Bar Seal		

	No. of Feet
Tear Seal	
Bar Seal	
Bar Seal	

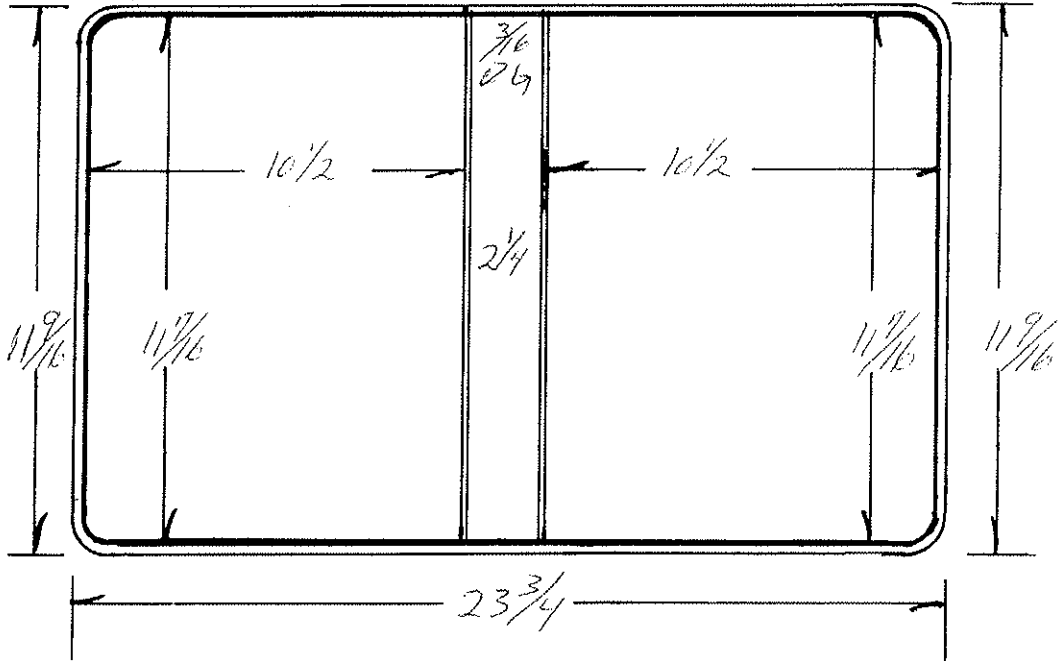

Code	Cutting Specs				Code	Cutting Specs			
	Ga.	# PCS	Size	Out		Ga.	# Pcs.	Size	Out
Cover Mat.			$12 \frac{3}{16} \times 24 \frac{1}{2}$	1	Lining Mat.			$12 \frac{3}{16} \times 24 \frac{1}{2}$	1
Cover Mat			X		Lining Mat.			X	
Vert. Pckt.			X		Horz. Pckt.			$5 \frac{3}{16} \times 24 \frac{7}{16}$	1
Vert. Pckt.			X		Horz. Pckt.			X	
Pocket			X		Pocket			X	
Label Holder			X		Card Holder			X	
Material			X		Material			X	
Material			X		Material			X	
Material			X		Material			X	
F.C. Board			$11 \frac{11}{32} \times 10 \frac{13}{32}$	1	B.C. Board			X	
B.C. Board			X		B.B. Board			$11 \frac{11}{32} \times 10 \frac{13}{32}$	1
Center Board			X		Board			$11 \frac{11}{32} \times 2 \frac{5}{32}$	1
Board			X		Strip			X	
Cover Pad			X		Strip			X	
					B.B. Pad			X	

Product Code E.0

Style Case Rings Binder

Sheet Size 11 X 9

Cap. 7/4

Die No. 3343

Order No. 948555

Plate

Customer

Financial Services Corp.

5/27/85

Metal
Total Vinyl <u>.030</u>
Quantity <u>150</u>
Date <u>5/31/85</u>
Type Corners <u>Rd.</u>
Radius <u>1/4</u>
Completed

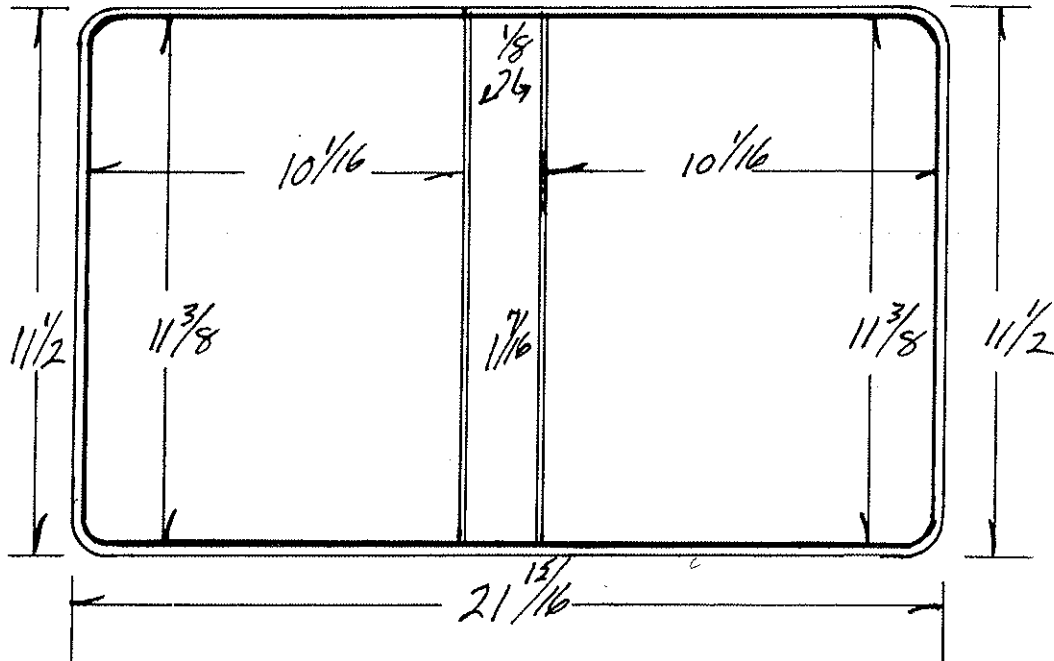

Material	Gauge	Thick
Tear Seal	10.3	1/8
Bar Seal	<u>10.3</u>	<u>1/8</u>
Bar Seal		

Material	No. of Feet
Tear Seal	
Bar Seal	
Bar Seal	

B.B. Bars m:11
TO .902

Code	Ga.	Pcs	Cutting Specs		Code	Ga.	Pcs	Cutting Specs	
			Size	Out				Size	Out
Cover Mat.			12 1/8	22 1/16	Lining Mat.			12 1/8	22 1/16
Cover Mat.			X		Lining Mat.			X	
Vert. Pckt.			X		Horz. Pckt.			5 3/16	10 3/16
Vert. Pckt.			X		Horz. Pckt.			X	
Pocket			X		Pocket			X	
Label Holder			X		Card Hlder			X	
Material			X		Material			X	
Material			X		Material			X	
Material			X		Material			X	
F.C. Board			11 9/32	9 31/32	B.C. Board			11 9/32	9 31/32
B.C. Board			X		B.B. Board			11 1/4	1 1/32
Center Board			X		Board			X	
Board			X		Strip			X	
Cover Pad			X		Strip			X	
					B.B. Pad			X	

Product Code

Style Case 2 METAL VRB.

Sheet Size 11 X 9

Cap. 2-1/2"

Die No. 3350

Order No. 964104

Plate

Customer

KREPE-KRAFT

Metal
Total Vinyl
Quantity 1000
Date 1-8-90
Type Corners
Radius 3/8"
Completed

	Gauge	Thick
Tear Seal		
Bar Seal		
Bar Seal		

	No. of Feet
Tear Seal	
Bar Seal	
Bar Seal	

51200 - B.P.

CHECKO-

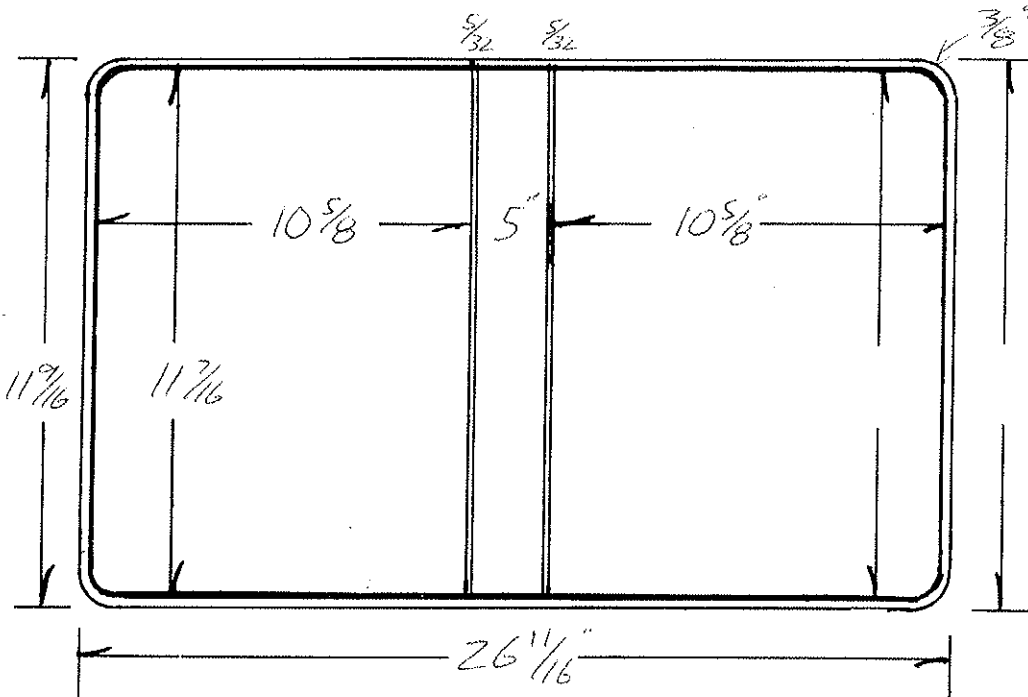

Code	Ga.	PCS	Cutting Specs		Code	Ga.	Pcs.	Cutting Specs	
			Size	Out				Size	Out
Cover Mat.		15	1		Lining Mat.		15	1	
	12 5/8 X 27 7/8					12 5/8 X 27 7/8			
Cover Mat	X				Lining Mat.	X			
Vert. Pckt.	X				Horz. Pckt.	5 3/8 X 11 1/8			
Vert. Pckt.	X				Horz. Pckt.	5 3/8 X 27 7/8			
Pocket	X				Pocket	X			
Label Holder	X				Card Holder	X			
Material	X				Material	X			
Material	X				Material	X			
Material	X				Material	X			
F.C. Board	11 1/32 X 10 1/32	1			B.C. Board	X			
B.C. Board	11 1/32 X 10 1/32	1			B.B. Board	11 1/32 X 4 29/32	1		
Center Board	X				Board	X			
Board	X				Strip	X			
Cover Pad	X				Strip	X			
					B.B. Pad	X			

Product Code E.C.

Style Case 1/2 Metal w/ 6 cap

Sheet Size 11 X 9

Cap. 3/4

Die No. 3389

Order No. 949491

Plate Casse

Customer	<u>Academy of Financial Planning 8/26/85</u>	
Metal		
Total Vinyl	<u>1030</u>	
Quantity	<u>300</u>	
Date	<u>9-10-85</u>	
Type Corners	<u>Rd</u>	
Radius	<u>1/4</u>	
Completed		

	Gauge	Thick
Tear Seal	<u>016</u>	<u>332</u>
Bar Seal	<u>178</u>	<u>316</u>
Bar Seal		

	No. of Feet
Tear Seal	
Bar Seal	
Bar Seal	

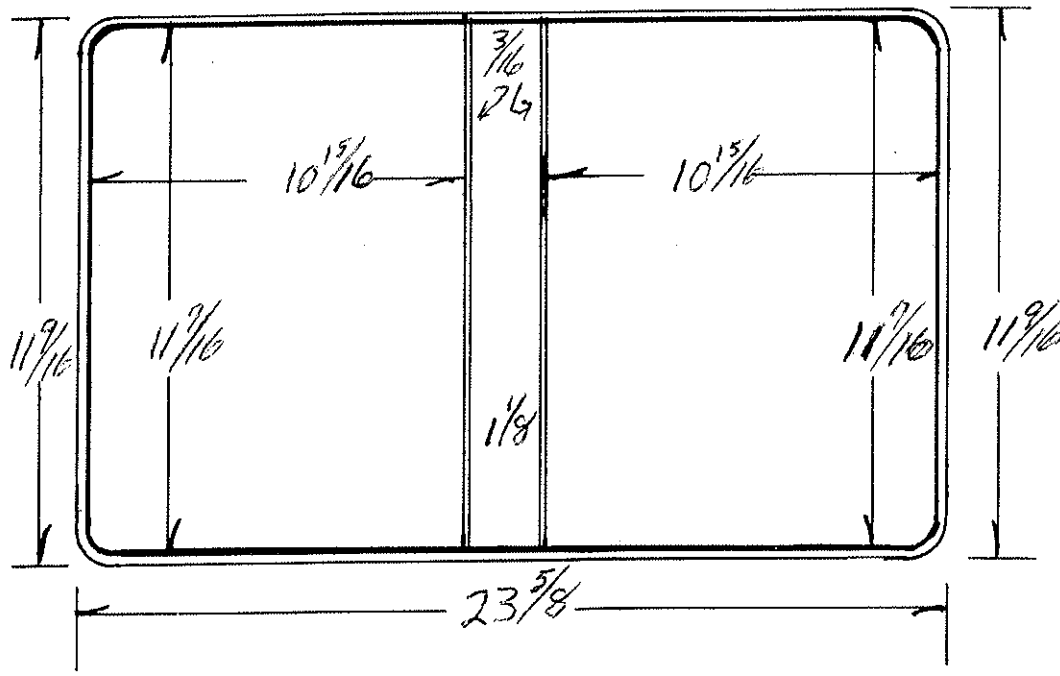

Code	Cutting Specs				Code	Cutting Specs					
	Ga.	PCS	Size	Out		Ga.	PCS	Size	Out		
Cover Mat.			<u>12 3/16 X 24 3/8</u>	<u>1</u>	Lining Mat.			<u>12 3/16 X 24 3/8</u>	<u>1</u>		
Cover Mat			X		Lining Mat.			X			
Vert. Pckt.			X		Horz. Pckt.			X			
Vert. Pckt.			X		Horz. Pckt.			X			
Pocket			X		Pocket			X			
Label Holder			X		Card Holder			X			
Material			X		Material			X			
Material			X		Material			X			
Material			X		Material			X			
F.C. Board			<u>11 1/32 X 10 27/32</u>	<u>120</u>	<u>1</u>	B.C. Board			<u>11 1/32 X 10 27/32</u>	<u>120</u>	<u>1</u>
B.C. Board			<u>11 3/8 X 10 7/8</u>	<u>100</u>	<u>2</u>	B.B. Board			<u>11 1/32 X 1 1/32</u>	<u>120</u>	<u>1</u>
Center Board	<u>BB</u>		<u>11 3/8 X 1 1/32</u>	<u>100</u>	<u>1</u>	Board			X		
Board			X		Strip			X			
Cover Pad			X		Strip			X			
					B.B. Pad			X			

DIE #	3635 SPECIAL	METAL	LOC	RADIUS	3/8"
ORDER #	987247	CUSTOMER	BRIAN KLEIN	TEAR SEAL	.016
SHEET SIZE	11 X 9	STYLE CASE	VRB	BAR SEAL	253
CAP.	1/2"	DUE DATE	5-28-97	COMPLETED	
LOCATION		QUANTITY	12	DATE	5-21-97

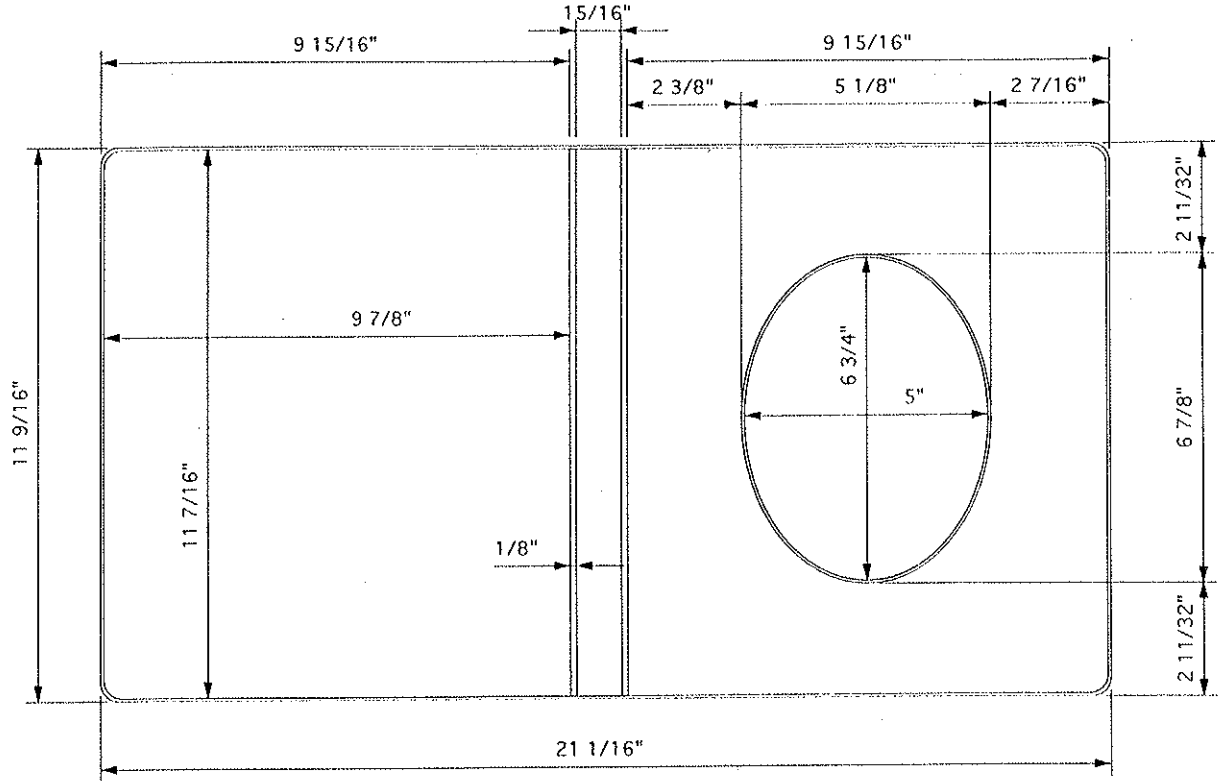

MATERIAL SPECS		GAUGE	PCS.	MATERIAL SPECS		GAUGE
COVER MAT.	12 9/16 X 22 1/8		1	LINING MAT.	12 5/16 X 22 13/16	
COVER MAT.				LINING MAT.		
DIE CUT				HORZ. PKT.	11 1/2 X 12 1/2	DIECUT 3635-B
COL				VERT. PKT.		
LABEL HOLDER				DIE CUT		
GUSSET				REINF.		
BOARD SPECS		GAUGE	PCS.	BOARD SPECS		GAUGE
(PADDED) F.C. BOARD	12 5/16 X 10 3/4	DIECUT 3635-C	100	1	F.C. BOARD	
B.B. BOARD	11 5/16 X 27/32		100	1	B.B. BOARD	
(PADDED) B.C. BOARD	11 5/16 X 9 3/4		100	1	B.C. BOARD	
FLAP BD.					DIE CUT	
BOARD					DIE CUT	

Product Code

Style Case Ring Binder

Sheet Size 11 X 9

Cap. 1/2

Die No. 3635

Order No. 58450

Plate

Customer

N.S.C INT'l

Metal
Total Vinyl <u>.030</u>
Quantity <u>1000</u>
Date <u>10/2/86</u>
Type Corners <u>Rd</u>
Radius <u>1/4</u>
Completed

	Gauge	Thick
Tear Seal	<u>.016</u>	<u>3/32</u>
Bar Seal	<u>72</u>	<u>1/8</u>
Bar Seal		

	No. of Feet
Tear Seal	
Bar Seal	
Bar Seal	

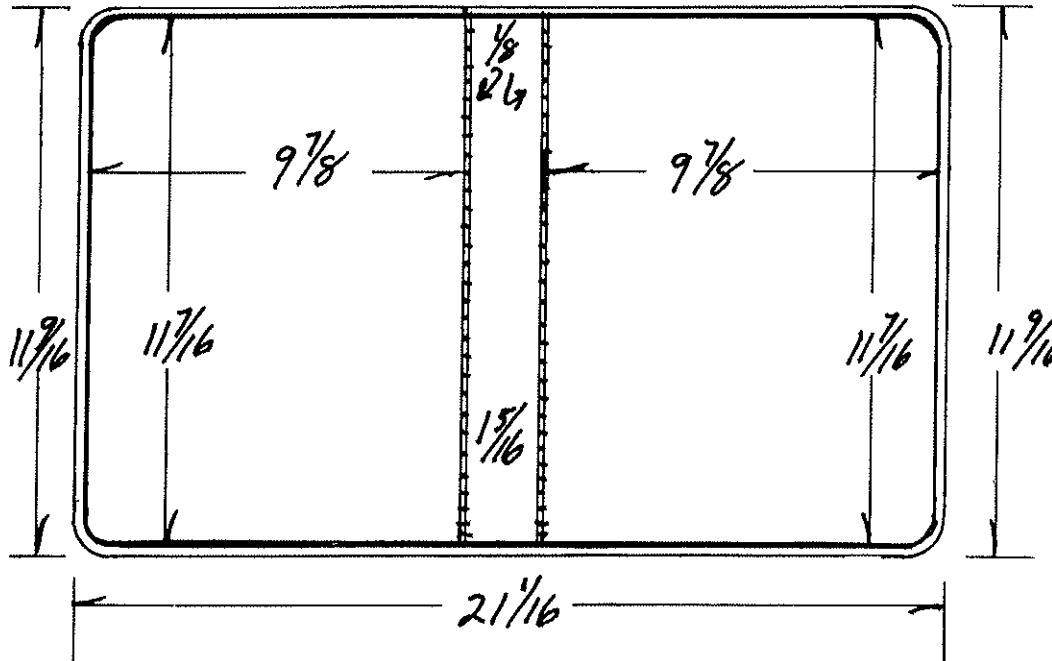

Code	Ga.	Pcs	Cutting Specs		Code	Ga.	Pcs	Cutting Specs	
			Size	Out				Size	Out
Cover Mat.		1	12 ^{3/16} X 21 ^{13/16}		Lining Mat.		1	12 ^{3/16} X 21 ^{13/16}	
Cover Mat			X		Lining Mat.			X	
Vert. Pckt.			X		Horz. Pckt.			5 ^{3/8} X 10 ^{3/8}	
Vert. Pckt.			X		Horz. Pckt.			5 ^{3/8} X 21 ^{13/16}	
Pocket			X		Pocket			X	
Label Holder			X		Card Holder			X	
Material			X		Material			X	
Material			X		Material			X	
Material			X		Material			X	
F.C. Board		1	11 ^{11/32} X 9 ^{25/32}		B.C. Board		1	11 ^{11/32} X 9 ^{25/32}	
B.C. Board			X		B.B. Board		1	11 ^{11/32} X 27 ^{1/32}	
Center Board			X		Board			X	
Board			X		Strip			X	
Cover Pad			X		Strip			X	
					B.B. Pad			X	

Product Code

Style Case *Everlasting Hinge*

Sheet Size *11 X 9*

Cap. *1 1/2*

Die No. *3597*

Order No. *83692*

Plate

Stock

Customer

Metal
Total Vinyl <i>.024</i>
Quantity
Date
Type Corners <i>Rd</i>
Radius <i>1/4</i>
Completed

	Gauge	Thick
Tear Seal	<i>.017</i>	<i>352</i>
Bar Seal	<i>89615</i>	<i>532</i>
Bar Seal	<i>20</i>	<i>132</i>

	No. of Feet
Tear Seal	
Bar Seal	
Bar Seal	

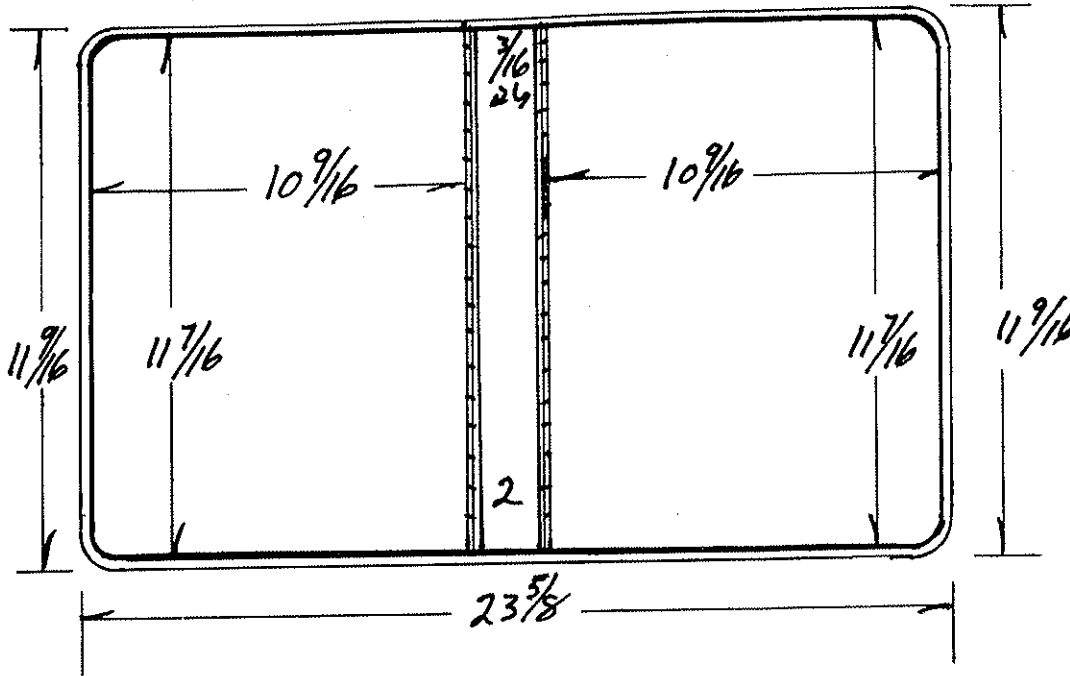

*Add #20 to inside
B.B. Bars*

*Same as die #109
w/everlast hinge*

Code		Cutting Specs		Code		Cutting Specs	
Ga.	# PCS	Size	Out	Ga.	# PCS	Size	Out
Cover Mat.		<i>12 3/16 X 24 3/8</i>	<i>1</i>	Lining Mat.		<i>12 3/16 X 24 3/8</i>	<i>1</i>
Cover Mat.		X		Lining Mat.		X	
Vert. Pckt.		X		Horz. Pckt.		<i>5 3/8 X 11 1/16</i>	
Vert. Pckt.		X		Horz. Pckt.		<i>5 3/8 X 24 3/4</i>	
Pocket		X		Pocket		X	
Label Holder		X		Card Hlder		X	
Material		X		Material		X	
Material		X		Material		X	
Material		X		Material		X	
F.C. Board		<i>11 1/32 X 10 1/32</i>	<i>1</i>	B.C. Board		<i>11 1/32 X 10 1/32</i>	<i>1</i>
B.C. Board		X		B.B. Board		<i>11 1/32 X 17 3/32</i>	<i>1</i>
Center Board		X		Board		X	
Board		X		Strip		X	
Cover Pad		X		Strip		X	
				B.B. Pad		X	

Product Code as Sample

Style Case Angle D Ring

Sheet Size 11 X 9 Cap. 1

Die No. 3612

Order No. 952822

Plate

SE Region Samples

Customer	
Metal	
Total Vinyl	<u>.030</u>
Quantity	<u>3-4</u>
Date	<u>8-25</u>
Type Corners	<u>Rd</u>
Radius	<u>1/4</u>
Completed	

	Gauge	Thick
Tear Seal	<u>.016</u>	<u>3/32</u>
Bar Seal	<u>72</u>	<u>1/8</u>
Bar Seal		

	No. of Feet
Tear Seal	
Bar Seal	
Bar Seal	

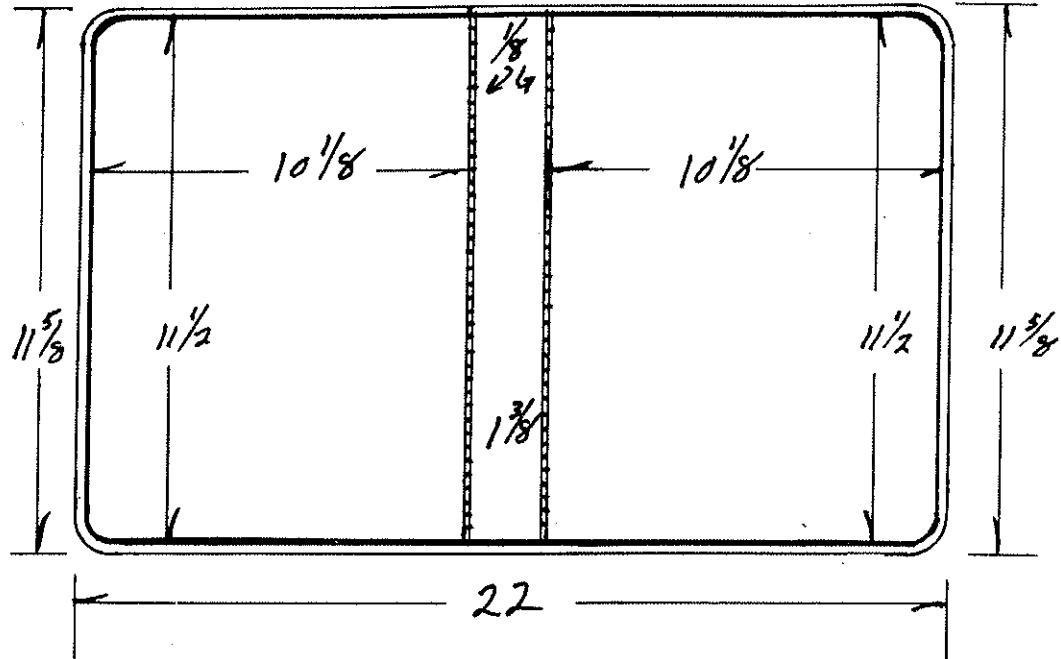

Code	Cutting Specs				Code	Cutting Specs			
	Ga.	PCS	Size	Out		Ga.	PCS	Size	Out
Cover Mat.			<u>12 1/4 X 22 5/8</u>	<u>1</u>	Lining Mat.			<u>12 1/4 X 22 5/8</u>	<u>1</u>
Cover Mat.			X		Lining Mat.			X	
Vert. Pckt.			X		Horz. Pckt.			<u>7 X 12 1/8</u>	<u>1</u>
Vert. Pckt.			X		Horz. Pckt.			X	
Pocket			X		Pocket			X	
Label Holder			X		Card Holder			X	
Material			X		Material			X	
Material			X		Material			X	
Material			X		Material			X	
F.C. Board			<u>11 1/16 X 10 1/32</u>	<u>100 1</u>	B.C. Board			<u>11 1/16 X 10 1/32</u>	<u>100 1</u>
F.C. Board			<u>11 1/16 X 10 1/16</u>	<u>100</u>	B.B. Board			<u>11 1/16 X 1 9/32</u>	<u>100 1</u>
B.C. Board			<u>11 1/16 X 10 1/16</u>	<u>100</u>	B.B. Board			<u>11 1/16 X 1 9/32</u>	<u>100</u>
Board			X		Strip			X	
Cover Pad			X		Strip			X	
					B.B. Pad			X	

Product Code

Style Case

Sheet Size 11 X 9

Cap. 1 1/2

Die No. 3642

Order No. 95335

Plate

Adv. Ang. 2 1/2

Customer

Harris / 3M

Metal
Total Vinyl .030
Quantity 100
Date 10-17-86
Type Corners R
Radius 1/4
Completed

	Gauge	Thick
Tear Seal	.016	3/32
Bar Seal	89bis	3/32
Bar Seal		

	No. of Feet
Tear Seal	
Bar Seal	
Bar Seal	

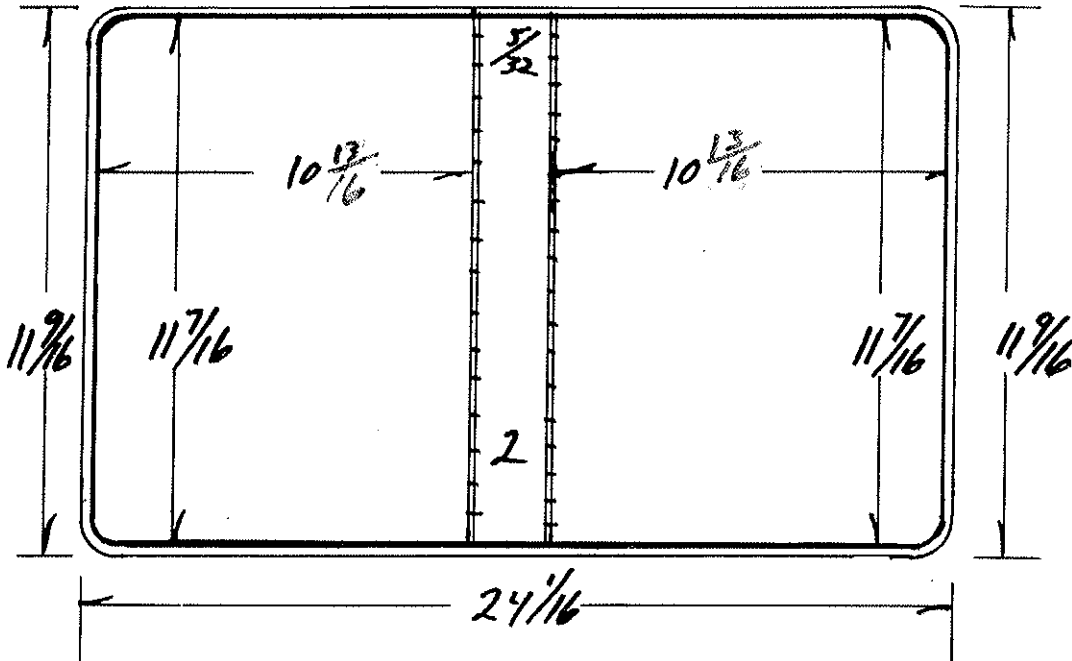

Code	Ga.	PCS	Cutting Specs		Code	Ga.	Pcs.	Cutting Specs	
			Size	Out				Size	Out
Cover Mat.		1	12 3/16 X 24 13/16		Lining Mat.		1	12 3/16 X 24 13/16	
Cover Mat			X		Lining Mat.			X	
Vert. Pckt.			X		Horz. Pckt.			X	
Vert. Pckt.			X		Horz. Pckt.			X	
Pocket			X		Pocket			X	
Label Holder			X		Card Holder			X	
Material			X		Material			X	
Material			X		Material			X	
Material			X		Material			X	
F.C. Board		120	1	11 11/32 X 10 23/32	B.C. Board		120	1	11 11/32 X 10 23/32
B.C. Board		100	2	11 3/8 X 10 3/4	B.B. Board		120	1	11 11/32 X 10 23/32
Center Board				X	Board		100	1	11 3/8 X 10 29/32
Board				X	Strip			X	
Cover Pad				X	Strip			X	
					B.B. Pad			X	

Product Code Same Size as 1" F.C. + B.C.

Style Case Ring Binder

Sheet Size 11 X 9

Cap. 2 1/2 Die No. 3648

Order No. 953204

Plate

Customer

Pickett Assoc.

Metal
Total Vinyl <u>.030</u>
Quantity <u>100</u>
Date <u>10-17-86</u>
Type Corners <u>Rd.</u>
Radius <u>1/4</u>
Completed

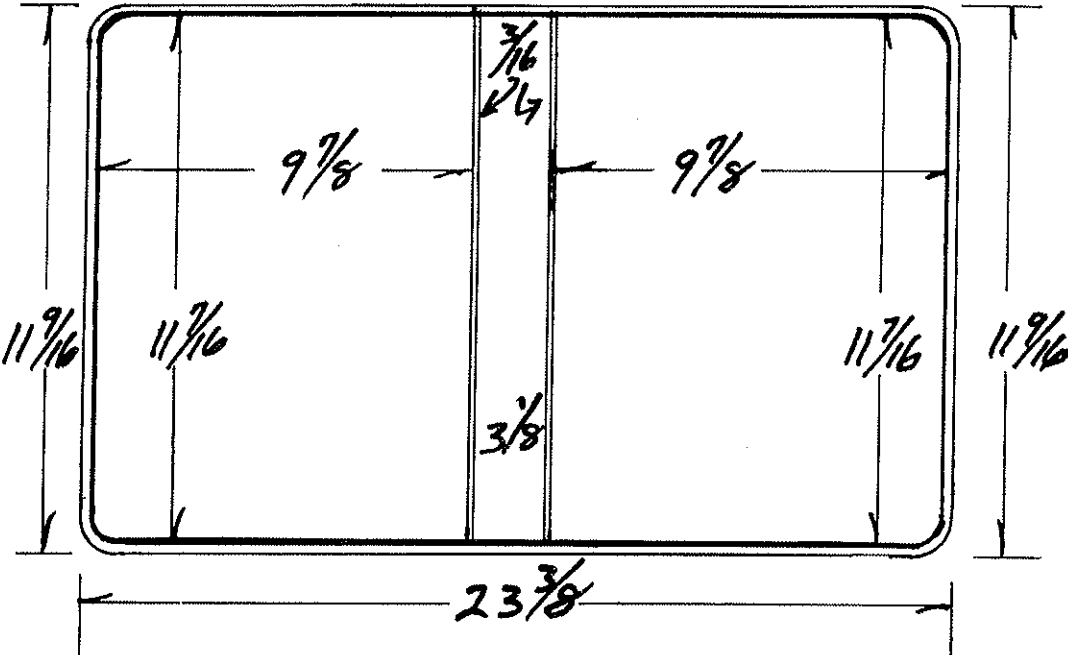

	Gauge	Thick
Tear Seal	<u>.016</u>	<u>3/32</u>
Bar Seal	<u>178</u>	<u>3/16</u>
Bar Seal		

	No. of Feet
Tear Seal	
Bar Seal	
Bar Seal	

Code	Ga.	# PCS	Cutting Specs		Code	Ga.	# Pcs.	Cutting Specs	
			Size	Out				Size	Out
Cover Mat.			<u>12 3/16 X</u>	<u>24 1/8</u>	Lining Mat.			<u>12 3/16 X</u>	<u>24 1/8</u>
Cover Mat.			X		Lining Mat.			X	
Vert. Pckt.			X		Horz. Pckt.			<u>5 3/8 X</u>	<u>10 3/8</u>
Vert. Pckt.			X		Horz. Pckt.			<u>5 3/8 X</u>	<u>24 1/8</u>
Pocket			X		Pocket			X	
Label Holder			X		Card Holder			X	
Material			X		Material			X	
Material			X		Material			X	
Material			X		Material			X	
F.C. Board			<u>11 1/32 X</u>	<u>9 25/32</u>	B.C. Board			<u>11 1/32 X</u>	<u>9 25/32</u>
B.C. Board			X		B.B. Board			<u>11 1/32 X</u>	<u>3 1/32</u>
Center Board			X		Board			X	
Board			X		Strip			X	
Cover Pad			X		Strip			X	
					B.B. Pad			X	

DIE #	3706-MOD	METAL	LOC	RADIUS	3/8"
ORDER #	672202	CUSTOMER	PK SPECIALTIES	TEAR SEAL	.014
SHEET SIZE	11 X 9	STYLE CASE	VRB W/WINDOW	BAR SEAL	253
CAP.	3/4"	DUE DATE	4-15-05	COMPLETED	
LOCATION		QUANTITY	45	DATE	4-7-05

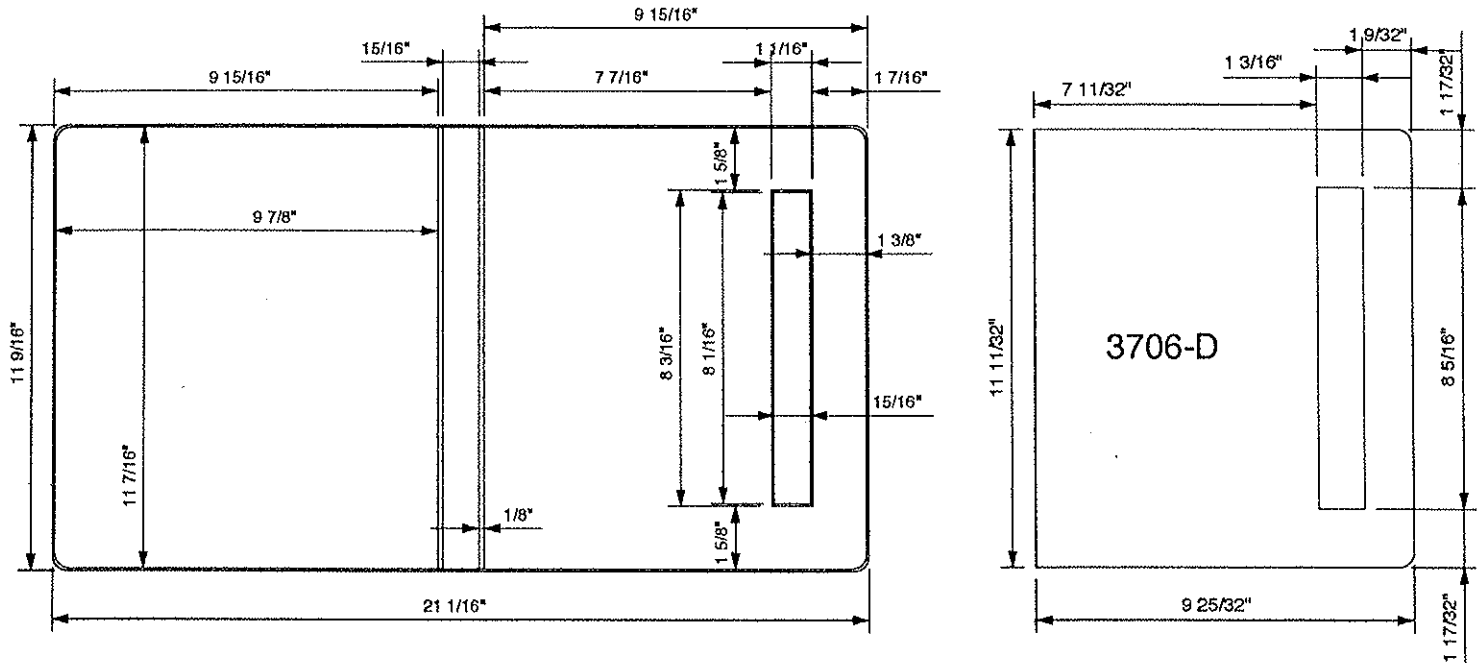

MATERIAL SPECS		GAUGE		MATERIAL SPECS		GAUGE	
COVER MAT.	12 5/16 X 21 13/16		1	LINING MAT.	12 5/16 X 21 13/16		1
COVER MAT.				LINING MAT.			
DIE CUT				HORZ. PKT. (5")	5 3/8 X 10 7/16		1
COL				HORZ. PKT. (4.5")			
LABEL HOLDER				DIE CUT			
GUSSET				REINF.			

BOARD SPECS		GAUGE		BOARD SPECS		GAUGE	
F.C. BOARD				F.C. BOARD			
B.B. BOARD	11 3/8 X 27/32	100	1	B.B. BOARD			
B.C. BOARD	11 3/8 X 9 13/16	100	1	B.C. BOARD			
FLAP BD.				DIE CUT			
PADDED FC				DIE CUT	12 3/8 X 10 13/16	100	1

Product Code

Style Case *Ring Binder w/Pad*

Sheet Size *11* X *9* Cap. *1*

Die No. **3725** Order No. *954213* Plate

Customer *Sherwin Williams*

Metal
Total Vinyl <i>.030</i>
Quantity <i>3000</i>
Date <i>1-27-87</i>
Type Corners <i>RD</i>
Radius <i>1/4</i>
Completed

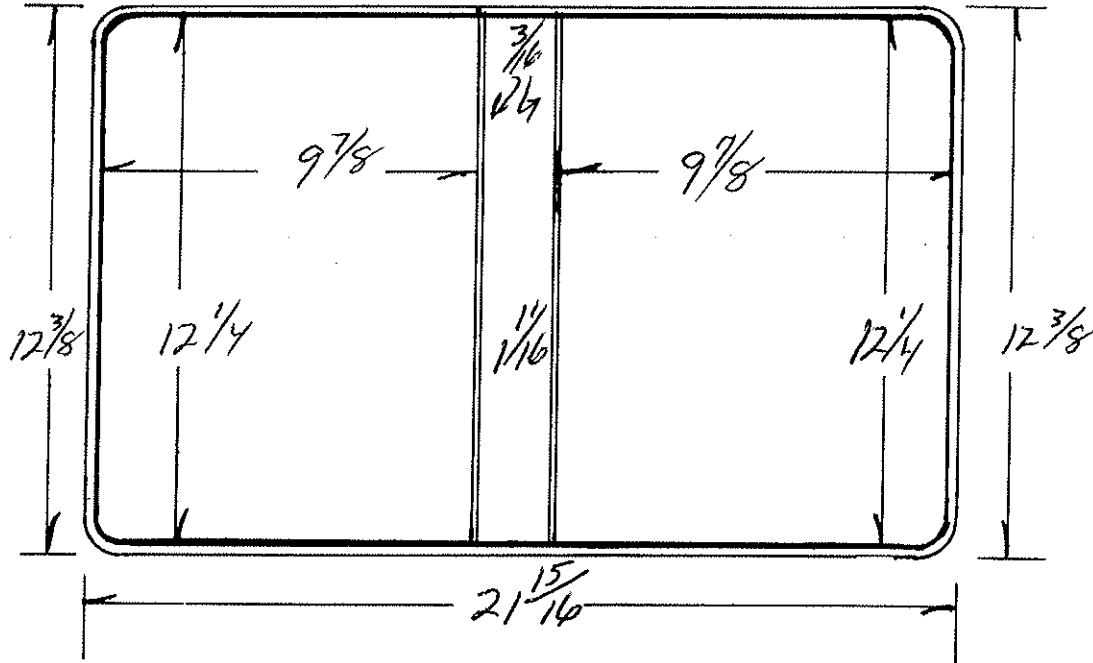

	Gauge	Thick
Tear Seal	<i>.016</i>	<i>3/32</i>
Bar Seal	<i>178</i>	<i>3/16</i>
Bar Seal		

	No. of Feet
Tear Seal	
Bar Seal	
Bar Seal	

Code	Cutting Specs				Code	Cutting Specs			
	Ga.	#	Size	Out		Ga.	#	Size	Out
Cover Mat.		<i>13</i>	<i>X 22 11/16</i>	<i>1</i>	Lining Mat.		<i>13</i>	<i>X 22 11/16</i>	<i>1</i>
Cover Mat.			<i>X</i>		Lining Mat.			<i>X</i>	
Vert. Pckt.			<i>X</i>		Horz. Pckt.		<i>12 1/2</i>	<i>22 9/16</i>	<i>1</i>
Vert. Pckt.			<i>X</i>		Horz. Pckt.		<i>5 3/8 X</i>	<i>10 7/16</i>	<i>1</i>
Pocket			<i>X</i>		Pocket		<i>12 1/2</i>	<i>10 7/16</i>	<i>1</i>
Label Holder			<i>X</i>		Card Holder			<i>X</i>	
Material			<i>X</i>		Material			<i>X</i>	
Material			<i>X</i>		Material			<i>X</i>	
Material			<i>X</i>		Material			<i>X</i>	
F.C. Board		<i>12 5/32 X</i>	<i>9 25/32</i>	<i>1</i>	B.C. Board		<i>12 5/32 X</i>	<i>9 25/32</i>	<i>1</i>
B.C. Board			<i>X</i>		B.B. Board		<i>12 5/32 X</i>	<i>1 1/32</i>	<i>1</i>
Center Board			<i>X</i>		Board			<i>X</i>	
Board			<i>X</i>		Strip			<i>X</i>	
Cover Pad			<i>X</i>		Strip			<i>X</i>	
					B.B. Pad			<i>X</i>	

Product Code Special FCB size

Style Case Ring Binder

Sheet Size 11 X 9

Cap. 1

Die No. 3744

Order No. 954463

Plate

Customer

Dictaphone

Metal
Total Vinyl <u>.030</u>
Quantity <u>700</u>
Date <u>2-20-87</u>
Type Corners <u>Rd</u>
Radius <u>1/4</u>
Completed

	Gauge	Thick
Tear Seal	<u>.016</u>	<u>3/32</u>
Bar Seal	<u>178</u>	<u>3/16</u>
Bar Seal		

	No. of Feet
Tear Seal	
Bar Seal	
Bar Seal	

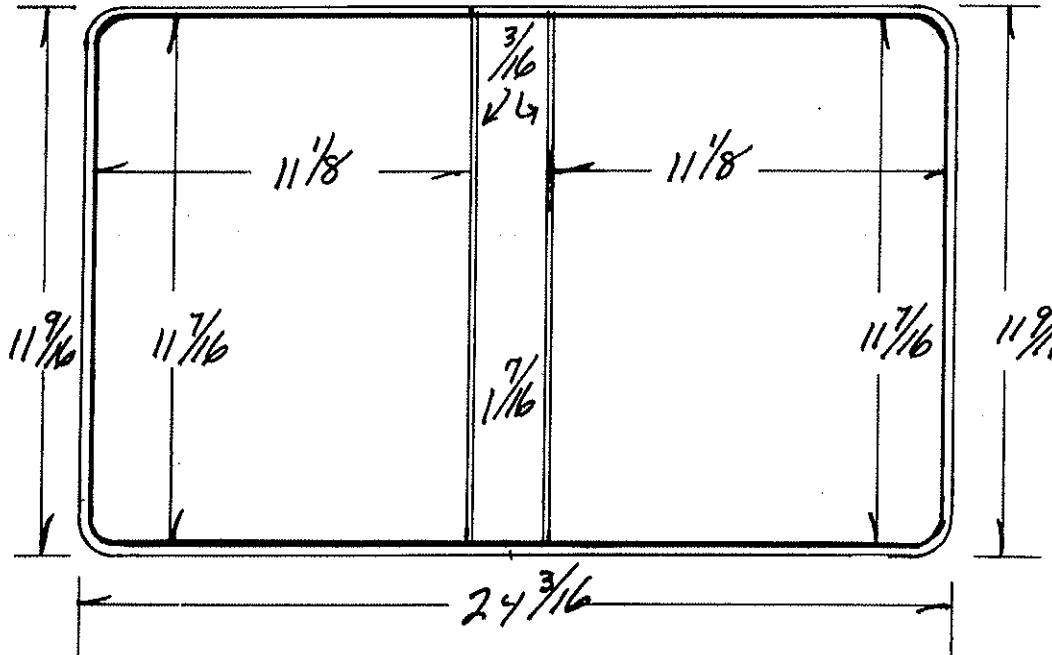

Code	Ga.	PCS	Cutting Specs		Code	Ga.	Pcs.	Cutting Specs	
			Size	Out				Size	Out
Cover Mat.		1	12 3/16 X 24 15/16		Lining Mat.		1	12 3/16 X 24 15/16	
Cover Mat.		X			Lining Mat.		X		
Vert. Pckt.		X			Horz. Pckt.		1	5 3/8 X 11 1/16	
Vert. Pckt.		X			Horz. Pckt.			5 3/8 X 24 15/16	
Pocket		X			Pocket		X		
Label Holder		X			Card Hlder		X		
Material		X			Material		X		
Material		X			Material		X		
Material		X			Material		X		
F.C. Board		1	11 1/32 X 11 1/32		B.C. Board		1	11 1/32 X 11 1/32	
B.G. Board		X			B.B. Board		1	11 1/32 X 1 1/32	
Center Board		X			Board		X		
Board		X			Strip		X		
Cover Pad		X			Strip		X		
					B.B. Pad		X		

Product Code

Style Case *Ring Binder*

Sheet Size *11 X 9*

Cap. *3 Rd.*

Die No. *3868*

Order No. *58675*

Plate

Customer

EBSCO Media

Metal
Total Vinyl <i>.030</i>
Quantity <i>550</i>
Date <i>8/28/87</i>
Type Corners <i>RD</i>
Radius <i>1/4</i>
Completed

	Gauge	Thick
Tear Seal	<i>.016</i>	<i>3/32</i>
Bar Seal	<i>178</i>	<i>3/16</i>
Bar Seal	<i>485</i>	

	No. of Feet
Tear Seal	
Bar Seal	
Bar Seal	

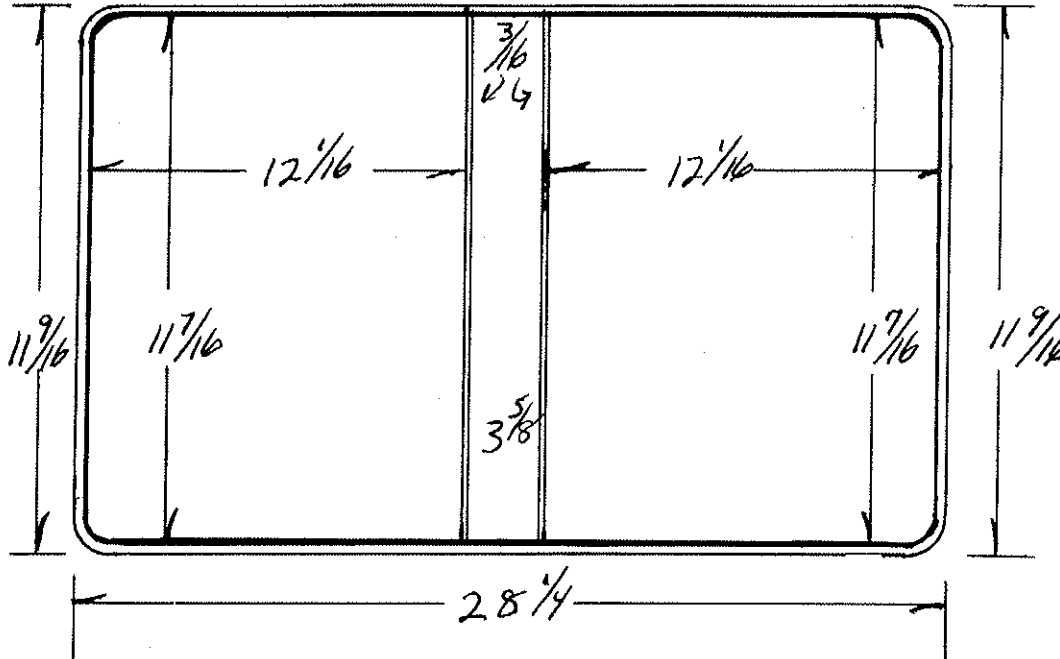

Code	Ga.	PCS	Cutting Specs		Code	Ga.	Pcs.	Cutting Specs	
			Size	Out				Size	Out
Cover Mat.		<i>12 3/16 X 29</i>		<i>1</i>	Lining Mat.		<i>12 3/16 X 29</i>		<i>1</i>
Cover Mat.		X			Lining Mat.		X		
Vert. Pckt.		X			Horz. Pckt.		<i>5 3/8 X 29</i>		
Vert. Pckt.		X			Horz. Pckt.		<i>5 3/8 X 12 9/16</i>		
Pocket		X			Pocket		X		
Label Holder		X			Card Holder		X		
Material		X			Material		X		
Material		X			Material		X		
Material		X			Material		X		
F.C. Board		<i>11 1/32 X 11 31/32</i>		<i>1</i>	B.C. Board		<i>11 1/32 X 11 31/32</i>		<i>1</i>
B.C. Board		X			B.B. Board		<i>11 1/32 X 3 17/32</i>		<i>(Cut BB)</i>
Center Board		X			Board		X		
Board		X			Strip		X		
Cover Pad		X			Strip		X		
					B.B. Pad		X		

Product Code

Style Case **VRB**

Sheet Size **11 X 9** Cap. **1 1/2** Die No. **3971** Order No. **1000151** Plate

Customer **Amway**

Metal
Total Vinyl
Quantity
Date
Type Corners RD
Radius 1/4
Completed

	Gauge	Thick
Tear Seal	16	3/32
Bar Seal	178	3/16
Bar Seal		

	No. of Feet
Tear Seal	
Bar Seal	
Bar Seal	

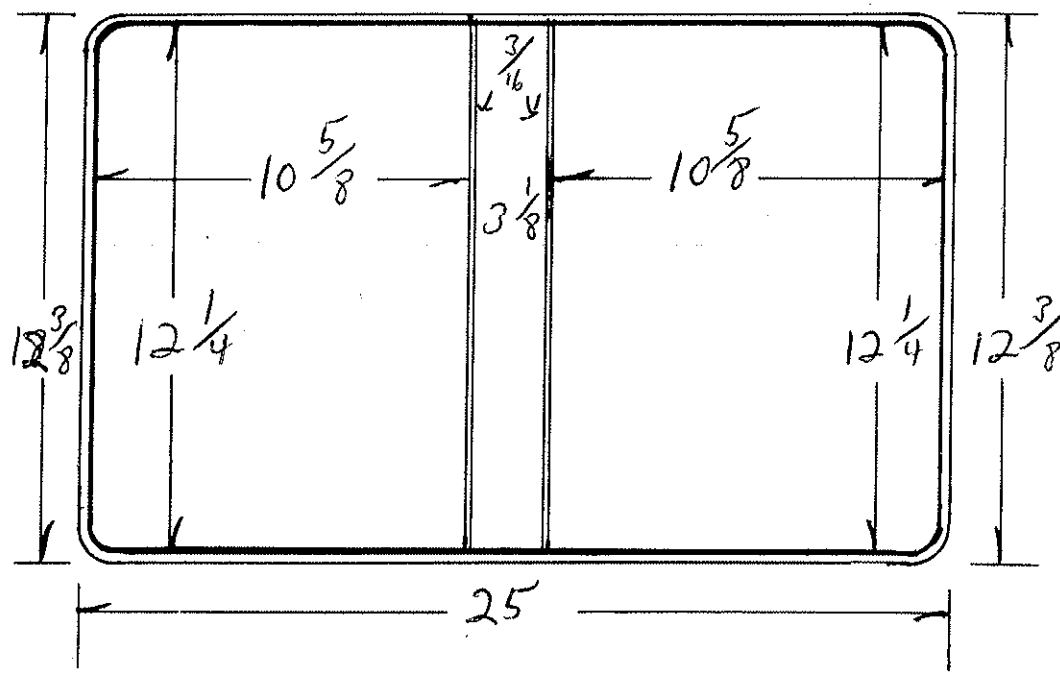

Code	Cutting Specs				Code	Cutting Specs			
	Ga.	PCS	Size	Out		Ga.	PCS	Size	Out
Cover Mat.		13	X 25 3/4	1	Lining Mat.		13 X 25 3/4	1	
Cover Mat.			X		Lining Mat.		X		
Vert. Pckt.			X		Horz. Pckt.		5 3/8 X 11 1/8		
Vert. Pckt.			X		Horz. Pckt.		5 3/8 X 25 3/4		
Pocket			X		Pocket		X		
Label Holder			X		Card Holder		X		
Material			X		Material		X		
Material			X		Material		X		
Material			X		Material		X		
F.C. Board			12 5/8 X 10 13/32	1	B.C. Board		12 5/8 X 10 13/32	1	
B.C. Board			X		B.B. Board		12 5/8 X 3 1/2	1	
Center Board			X		Board		X		
Board			X		Strip		X		
Cover Pad			X		Strip		X		
					B.B. Pad		X		

Product Code *as sample in height*
 Change TO $\frac{1}{2}$ " Cap. & Add TO F.C. & B.C.
 Sheet Size X Cap.

Style Case Ring Binder speci
 Order No. *958452* Plate

Die No. *3990*

Customer

Murtis 1000, Inc.

Metal	
Total Vinyl	<i>.030</i>
Quantity	<i>1000</i>
Date	<i>3-25-88</i>
Type Corners	<i>Rd</i>
Radius	<i>1/4</i>
Completed	

	Gauge	Thick
Tear Seal	<i>.016</i>	<i>187</i>
Bar Seal	<i>253</i>	<i>1/8</i>
Bar Seal		

	No. of Feet
Tear Seal	
Bar Seal	
Bar Seal	

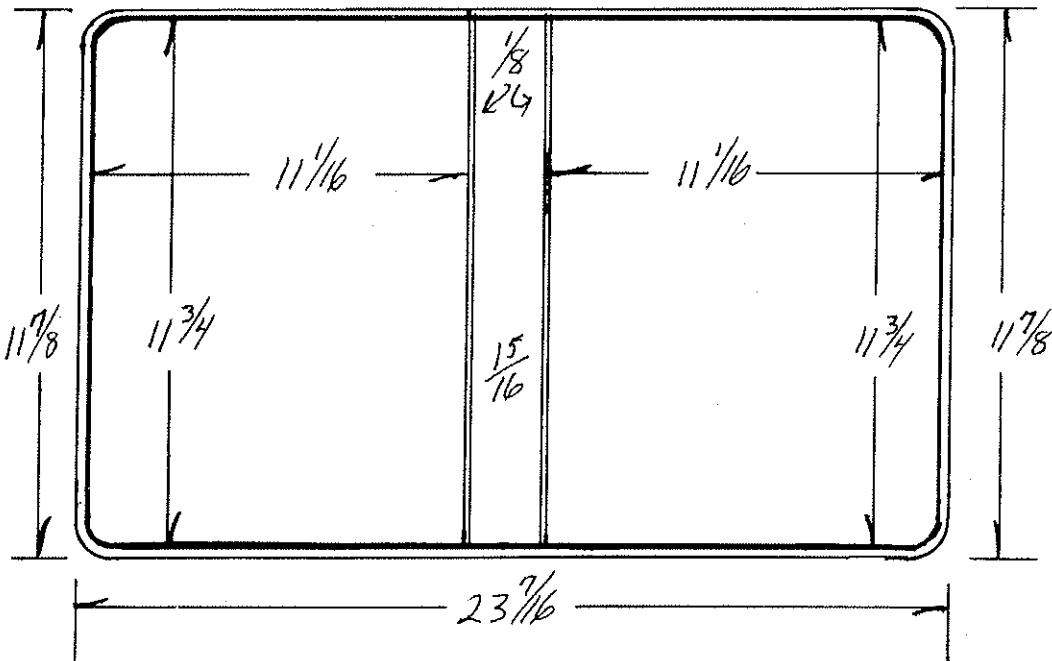

Code		Cutting Specs				Code		Cutting Specs			
		Ga.	# PCS	Size	Out			Ga.	# Pcs.	Size	Out
Cover Mat.	$12\frac{1}{2} \times 24\frac{3}{16}$		1			Lining Mat.	$12\frac{1}{2} \times 24\frac{3}{16}$				
Cover Mat	X					Lining Mat.	X				
Vert. Pckt.	X					Horz. Pckt.	$5\frac{3}{8} \times 11\frac{9}{16}$		1		
Vert. Pckt.	X					Horz. Pckt. Col	$11\frac{15}{16} \times 13\frac{1}{8}$		1		
Pocket	X					Pocket Horiz	$5\frac{3}{8} \times 24\frac{3}{16}$				
Label Holder	X					Card Holder	X				
Material	X					Material	X				
Material	X					Material	X				
Material	X					Material	X				
F.C. Board	$11\frac{21}{32} \times 10\frac{31}{32}$		1			B.C. Board	$11\frac{21}{32} \times 10\frac{31}{32}$		1		
B.C. Board	X					B.B. Board	$11\frac{21}{32} \times 2\frac{7}{32}$				
Center Board	X					Board	X				
Board	X					Strip	X				
Cover Pad	X					Strip	X				
						B.B. Pad	X				

Product Code

Style Case V R D Ribbed Hinge

Sheet Size 11 5/8 x 8 3/4 Cap. 20 1/4 Die No. 4023

Order No. 958876 Plate

Customer Compugraphic

Metal
Total Vinyl
Quantity <u>100</u>
Date
Type Corners <u>RD</u>
Radius <u>1/4</u>
Completed

	Gauge	Thick
Tear Seal	<u>1 1/2</u>	
Bar Seal	<u>Ribbed</u>	<u>Hinge</u>
Bar Seal		

	No. of Feet
Tear Seal	
Bar Seal	
Bar Seal	

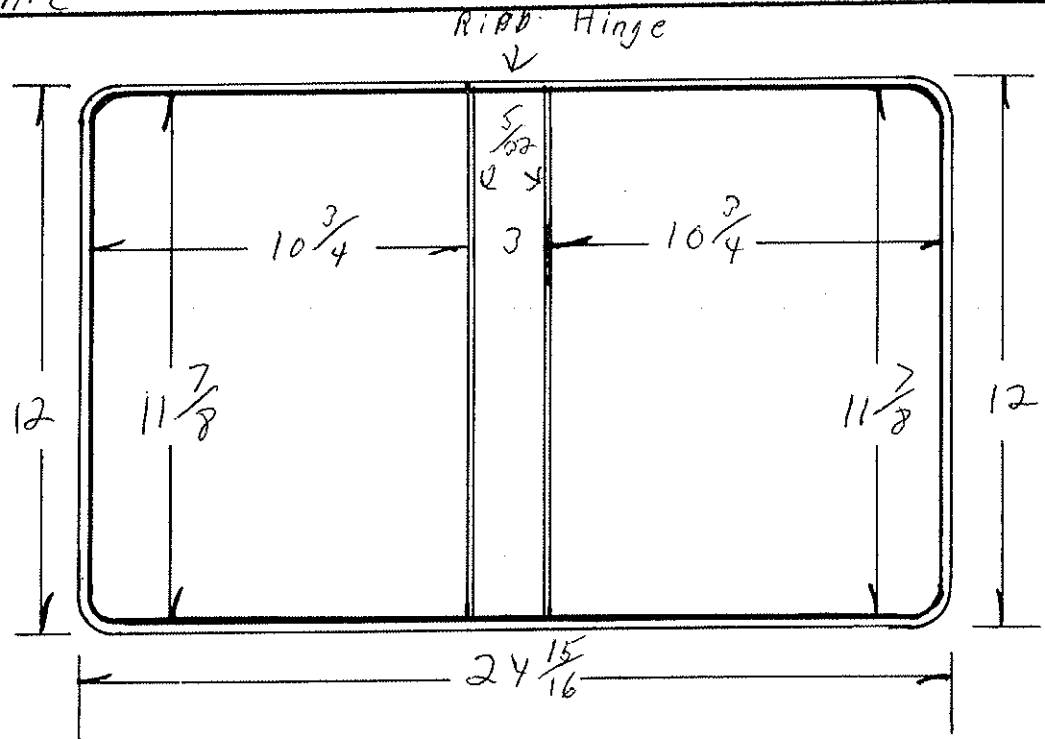

Code	Cutting Specs				Code	Cutting Specs			
	Ga.	Pcs.	Size	Out		Ga.	Pcs.	Size	Out
Cover Mat.			<u>12 5/8 x 25 11/16</u>	<u>1</u>	Lining Mat.			<u>12 5/8 x 25 11/16</u>	<u>1</u>
Cover Mat.			X		Lining Mat.			X	
Vert. Pckt.			X		Horz. Pckt.			<u>12 X 14 1/2</u>	<u>1</u> <u>Clar</u>
Vert. Pckt.			X		Horz. Pckt.			<u>5 3/8 X 11 1/4</u>	
Pocket			X		Pocket			<u>Horiz 5 3/8 X 25 11/16</u>	
Label Holder			X		Card Holder			X	
Material			X		Material			X	
Material			X		Material			X	
Material			X		Material			X	
F.C. Board			<u>11 25/32 x 10 21/32</u>	<u>1</u>	B.C. Board			<u>11 25/32 x 10 21/32</u>	<u>1</u>
B.G. Board			X		B.B. Board			<u>11 25/32 x 2 29/32</u>	<u>1</u>
Center Board			X		Board			X	
Board			X		Strip			X	
Cover Pad			X		Strip			X	
					B.B. Pad			X	

Product Code

Style Case

Sheet Size 11 x 9 3/4 Cap.

Die No. 4031

Order No. 959203 Plate

Customer Tim Walter Resources

Metal
Total Vinyl
Quantity
Date
Type Corners
Radius
Completed

Tear Seal	Gauge	Thick
Bar Seal	17	1/32
Bar Seal	172	3/16

Tear Seal	No. of Feet
Bar Seal	
Bar Seal	

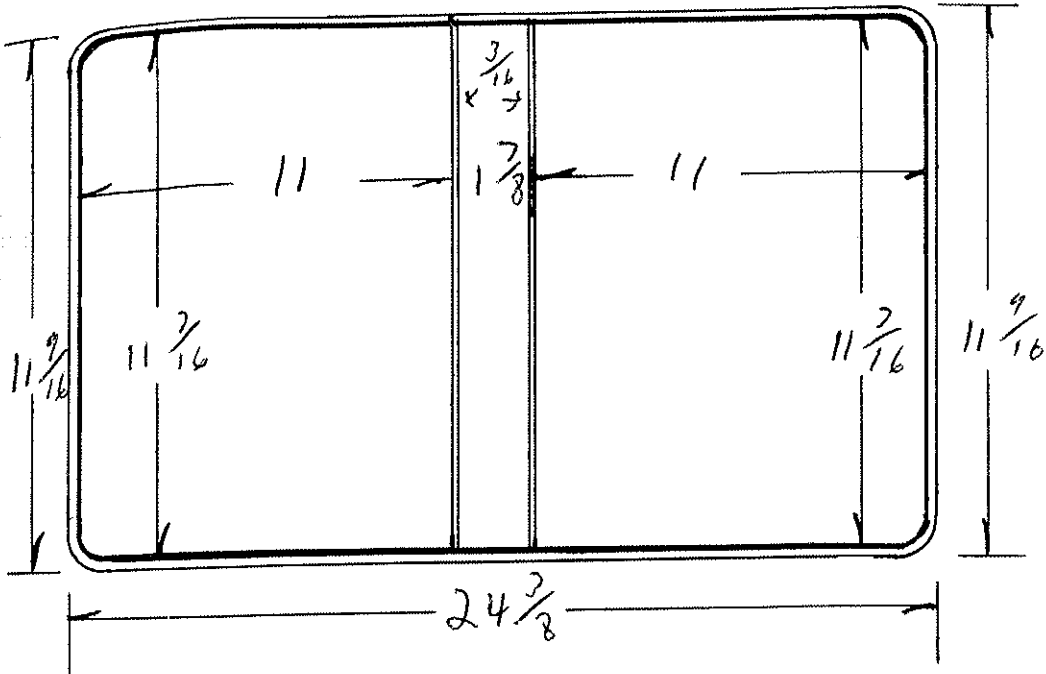

Code		Cutting Specs.				Code		Cutting Specs.			
		Ga.	#	Size	#			Ga.	#	Size	#
Cover Mat.	12 3/16 x 25 1/8		1			Lining Mat.	12 3/16 x 25 1/8		1		
Cover Mat.	X					Lining Mat.	X				
Vert. Pckt.	X					Horz. Pckt.	5 3/8 x 11 1/2				
Vert. Pckt.	X					Horz. Pckt.	5 3/8 x 25 1/8				
Pocket	X					Pocket	X				
Label Holder	X					Card Holder	X				
Material	X					Material	X				
Material	X					Material	X				
Material	X					Material	X				
F.C. Board	11 1/32 x 10 29/32		1			B.C. Board	11 1/32 x 10 29/32		1		
B.C. Board	X					B.B. Board	11 1/32 x 1 25/32		1		
Center Board	X					Board	X				
Board	X					Strip	X				
Cover Pad	X					Strip	X				
						B.B. Pad	X				

Product Code

Style Case VRB

Sheet Size 11 x 9

Cap. 1

Die No. 4103

Order No. 961094.1

Plate

Customer DIGITAL

Metal
Total Vinyl
Quantity
Date
Type Corners <u>AND</u>
Radius <u>7/8</u>
Completed

Gauge	Thick
Tear Seal <u>.016</u>	<u>3/32</u>
Bar Seal <u>.016</u>	<u>1/8</u>
Bar Seal	

No. of Feet
Tear Seal
Bar Seal
Bar Seal

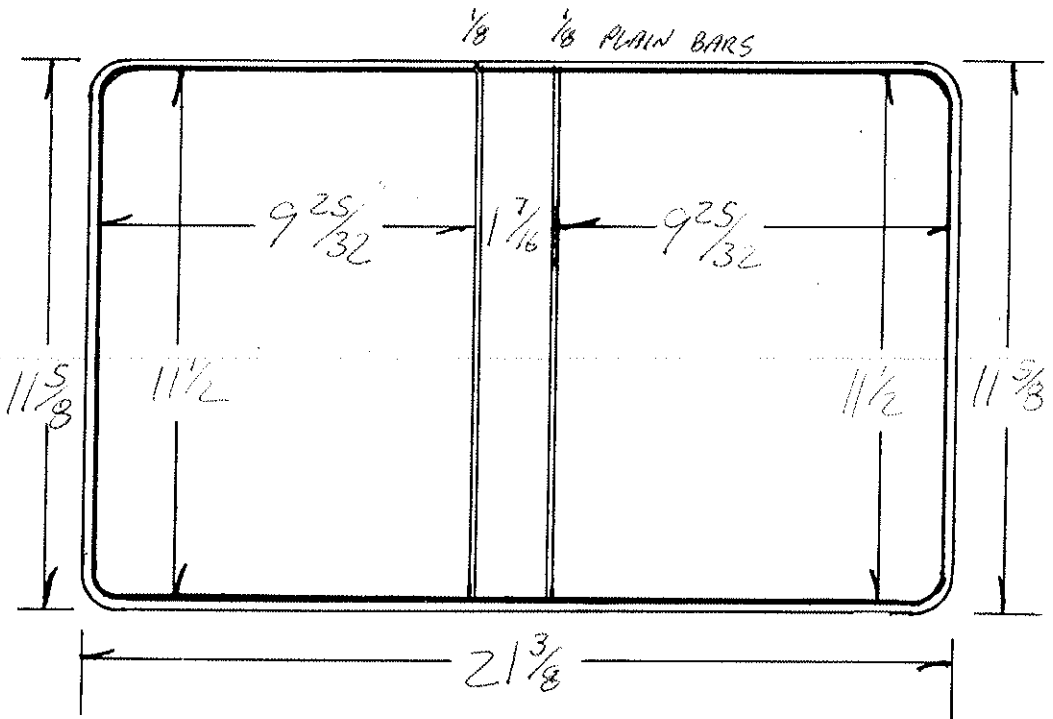

Code	Ga.	PCS	Cutting Specs		Code	Ga.	Pcs.	Cutting Specs		
			Size	Out				Size	Out	
Cover Mat.			<u>12 3/8 x 22 1/8</u>	<u>15</u>	<u>1</u>	Lining Mat.		<u>12 3/8 x 22 1/8</u>	<u>15</u>	<u>1</u>
Cover Mat			X		Lining Mat.		X			
Vert. Pckt.			X		Horz. Pckt.		<u>5 3/8 x 10 1/2</u>	<u>15</u>	<u>1</u>	
Vert. Pckt.			X		Horz. Pckt.		<u>5 3/8 x 22 1/8</u>			
Pocket			X		Pocket		X			
Label Holder			<u>7 1/4 x 2 1/2</u>	<u>10</u>	<u>1</u>	Card Holder		X		
Material			X <u>GRAN</u>		Material		X <u>GRAN</u>			
Material			X <u>DIRECTOR</u>		Material		X <u>DIRECTOR</u>			
Material			X <u>V</u>		Material		X <u>V</u>			
B.C. Board			<u>11 13/32 x 9 11/16</u>	<u>100</u>	<u>1</u>	B.C. Board		<u>11 13/32 x 9 11/16</u>	<u>100</u>	<u>1</u>
B.C. Board			X		B.B. Board		<u>1 1/32 x 11 13/32</u>			
Center Board			X		Board		X			
Board			X		Strip		X			
Cover Pad			X		Strip		X			
					B.B. Pad		X			

Product Code

Style Case

VRB.

Sheet Size 11 X 9 Cap. 1

Die No. 4110

Order No. 961256.1

Plate

Customer SABRE PRINTERS

Metal
Total Vinyl
Quantity
Date
Type Corners RND
Radius 3/8
Completed

	Gauge	Thick
Tear Seal	16	3/32
Bar Seal		5/32
Bar Seal		

	No. of Feet
Tear Seal	
Bar Seal	
Bar Seal	

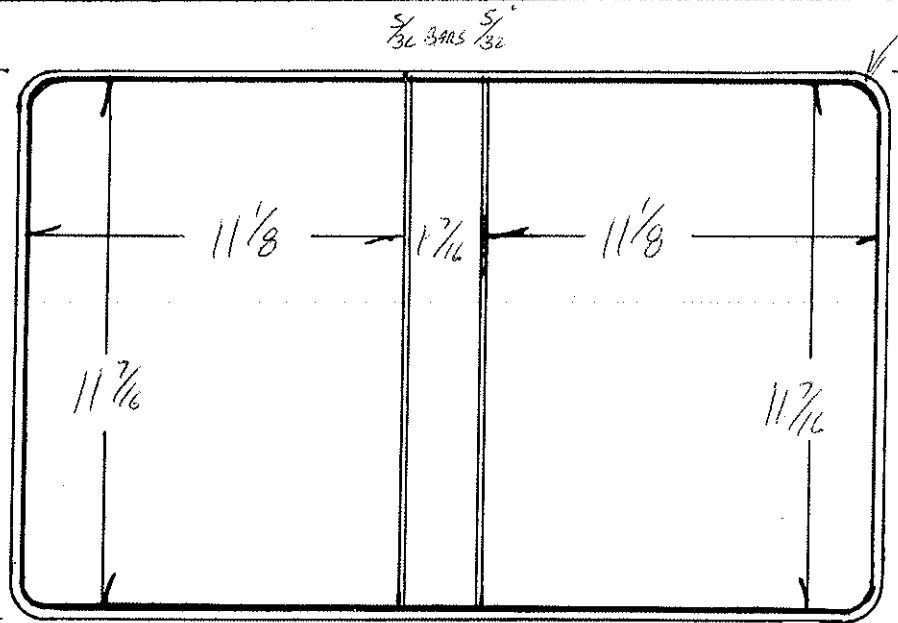

* PANELS ARE SAME AS 2" VRB
 W/ 1" BACK BONE PER ORDER

Code	Ga.	Pcs	Cutting Specs		Code	Ga.	Pcs	Cutting Specs	
			Size	Out				Size	Out
Cover Mat.			12 3/16	24 7/8	Lining Mat.			12 3/16	24 7/8
Cover Mat.			X		Lining Mat.			X	
Vert. Pckt.			X		Horz. Pckt.			5 3/8 X 11 5/8	
Vert. Pckt.			X		Horz. Pckt.			5 3/8 X 24 7/8	
Pocket			X		Pocket			X	
Label Holder			X		Card Holder			X	
Material			X		Material			X	
Material			X		Material			X	
Material			X		Material			X	
F.C. Board			STOCK	2"	B.C. Board			X	
B.C. Board			(11 1/32 X 11 1/32)		B.B. Board			11 1/32 X 1 1/32	100 1
Center Board			X		Board			X	
Board			X		Strip			X	
Cover Pad			X		Strip			X	
					B.B. Pad			X	

Product Code As Sample OLD # 3067 Style Case VRB
 FRONT cover Sheet Size 11 1/2 x 10 1/2 Cap. 1 1/2 Die No. 4123 Order No. 961481 ^{943451 ORIGINAL} _{CURRENT} Plate

Customer
Metal
Total Vinyl
Quantity
Date <u>1-19-89 S.P.</u>
Type Corners <u>RND</u>
Radius <u>3/8"</u>
Completed

JOHNSON PUBLISHING

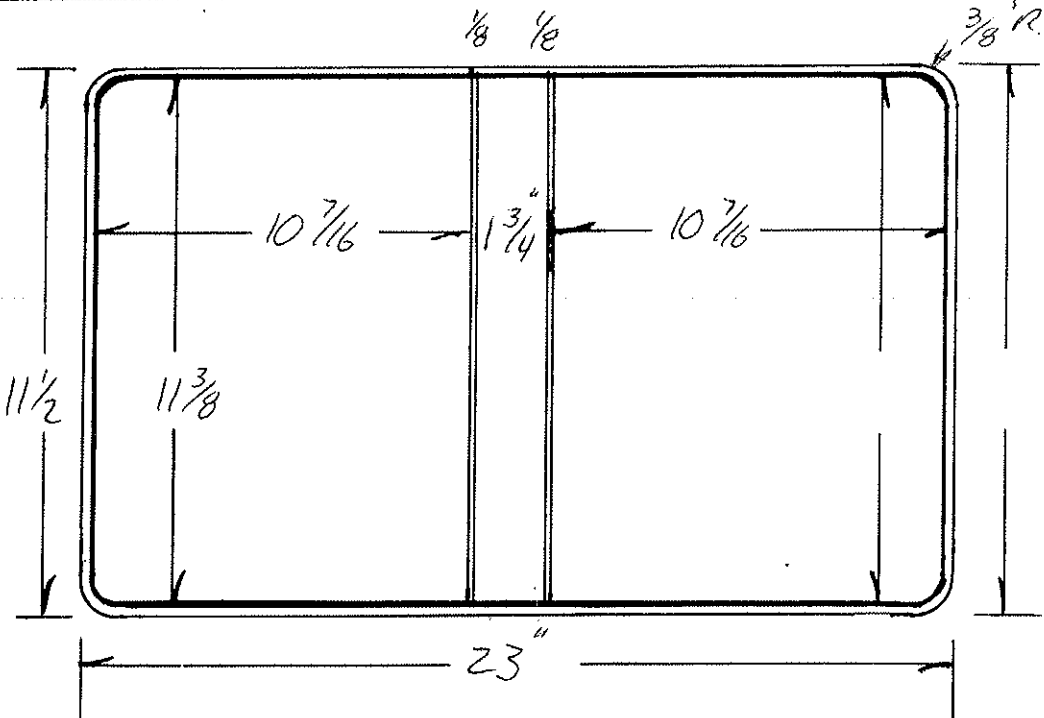

	Gauge	Thick
Tear Seal		
Bar Seal		
Bar Seal		

	No. of Feet
Tear Seal	
Bar Seal	
Bar Seal	

ORIGINAL DIE MADE 11-23-89

Code	Ga.	# PCS	Cutting Specs		Code	Ga.	# Pcs.	Cutting Specs	
			Size	Out				Size	Out
Cover Mat.		15	1		Lining Mat.	15	1		
Cover Mat.					Lining Mat.				
Vert. Pckt.					Horz. Pckt.				
Vert. Pckt.					Horz. Pckt.				
Pocket					Pocket				
Label Holder					Card Holder				
Material					Material				
Material					Material				
Material					Material				
F.C. Board		100	1		B.C. Board				
B.C. Board		100	1		B.B. Board				
Center Board					Board				
Board					Strip				
Cover Pad					Strip				
					B.B. Pad				

Product Code

Style Case *CVRB*

Sheet Size *11 x 9* Cap. *1/2"* Die No. *4148* Order No. *961662.1* Plate

Customer *HARRIS COMP. SYS.*

Metal
Total Vinyl
Quantity
Date <i>2-21-89</i>
Type Corners <i>RND.</i>
Radius <i>3/8"</i>
Completed

	Gauge	Thick
Tear Seal	<i>16</i>	<i>7/32</i>
Bar Seal		<i>3/16</i>
Bar Seal		

	No. of Feet
Tear Seal	
Bar Seal	
Bar Seal	

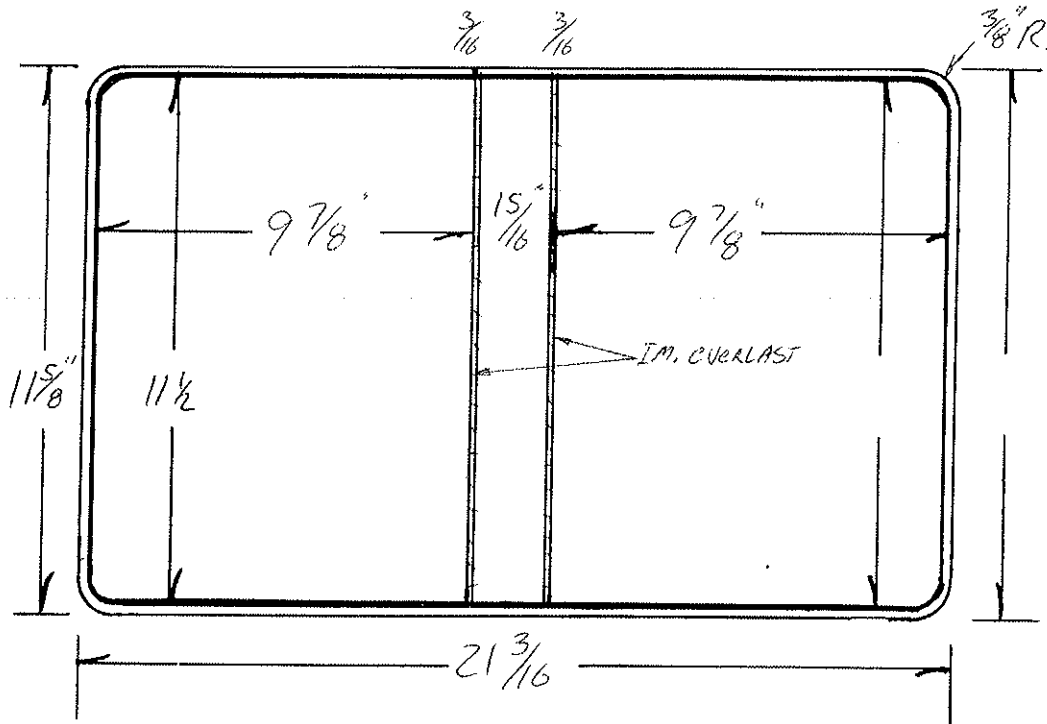

SPECIAL HEIGHT FOR HARRIS
 $11 \frac{5}{8}$ PER BNF.-T.G.-S.F.

SIZED FROM ART.

		Cutting Specs						Cutting Specs			
Code		Ga.	# PCS	Size	Out	Code		Ga.	# Pcs.	Size	Out
Cover Mat.	$12 \frac{3}{8} \times 22$	<i>15</i>	<i>1</i>			Lining Mat.	$12 \frac{3}{8} \times 22$	<i>15</i>	<i>1</i>		
Cover Mat.	X					Lining Mat.	X				
Vert. Pckt.	X					Horz. Pckt.	$5 \frac{3}{8} \times 10 \frac{3}{8}$				
Vert. Pckt.	X					Horz. Pckt.	$5 \frac{3}{8} \times 22$				
Pocket	X					Pocket	X				
Label Holder	X					Card Holder	X				
Material	X					Material	X				
Material	X					Material	X				
Material	X					Material	X				
F.C. Board	$11 \frac{13}{32} \times 9 \frac{25}{32}$	<i>100</i>	<i>1</i>			B.C. Board	X				
B.G. Board	$11 \frac{13}{32} \times 9 \frac{25}{32}$	<i>100</i>	<i>1</i>			B.B. Board	$11 \frac{13}{32} \times 2 \frac{7}{32}$	<i>100</i>	<i>1</i>		
Center Board	$11 \frac{7}{16} \times 9 \frac{13}{16}$	<i>100</i>	<i>2</i>			Board	X				
Board	$11 \frac{7}{16} \times 2 \frac{7}{32}$	<i>100</i>	<i>1</i>			Strip	X				
Cover Pad	X					Strip	X				
						B.B. Pad	X				

Product Code

Style Case VRB

Sheet Size 11 1/4 x 8 3/4 Cap. 1"

Die No. 4161

Order No. 962020

Plate

Customer ORIENTAL LAQUER FURNITURE

Metal
Total Vinyl
Quantity <u>1500</u>
Date <u>3-10-89</u>
Type Corners <u>RNO</u>
Radius <u>3/8"</u>
Completed

	Gauge	Thick
Tear Seal	<u>16</u>	<u>3/32</u>
Bar Seal		<u>1/8"</u>
Bar Seal		

	No. of Feet
Tear Seal	
Bar Seal	
Bar Seal	

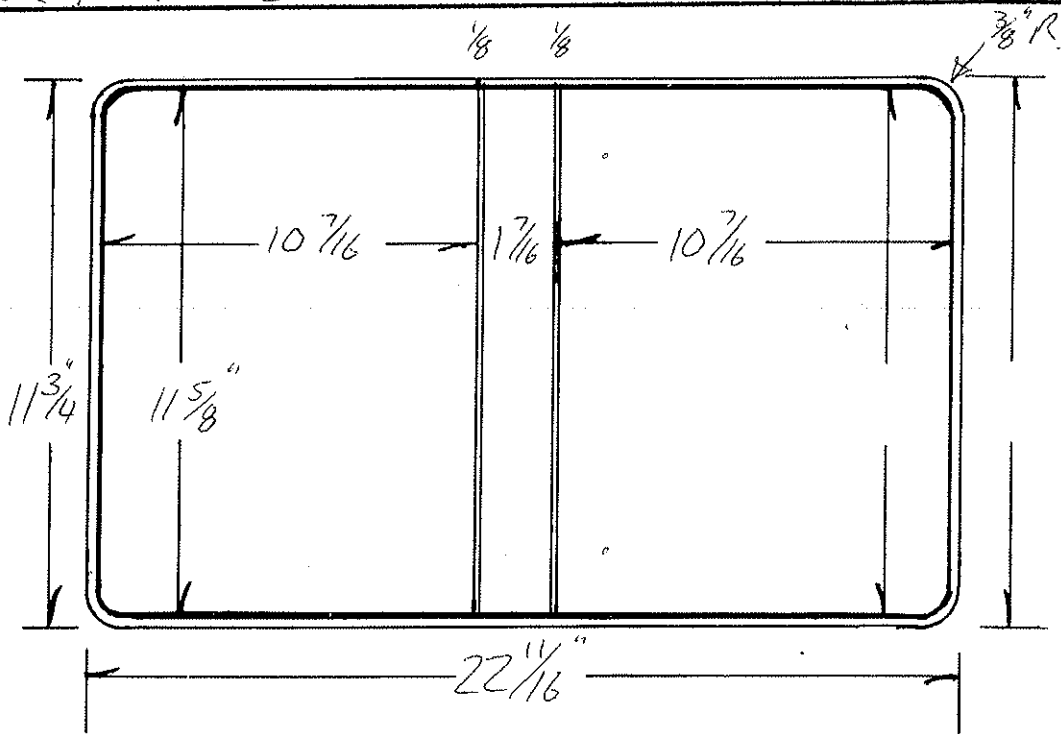

Code	Ga.	Pcs	Cutting Specs		Code	Ga.	Pcs	Cutting Specs					
			Size	Out				Size	Out				
Cover Mat.			12 1/4	23 1/2	15	1	Lining Mat.			12 1/4	23 1/2	15	1
Cover Mat				X			Lining Mat.				X		
Vert. Pckt.				X			Horz. Pckt.			5 3/8	23 1/2		
Vert. Pckt.				X			Horz. Pckt.			5 3/8	11"	15	1
Pocket				X			Pocket				X		
Label Holder				X			Card Holder				X		
Material				X			Material				X		
Material				X			Material				X		
Material				X			Material				X		
F.C. Board			11 1/32	10 1/32	100	1	B.C. Board				X		
B.C. Board			11 1/32	10 1/32	100	1	B.B. Board			11 1/32	1 1/32"	100	1
Center Board				X			Board				X		
Board				X			Strip				X		
Cover Pad				X			Strip				X		
							B.B. Pad				X		

Product Code

Style Case **VRB**

Sheet Size **11 x 9** Cap. **3"**

Die No. **4174**

Order No. **962124**

Plate

Customer **HARRIS CORP GOVT. INFO. SYS. DIV.**

Metal
Total Vinyl
Quantity
Date
Type Corners
Radius
Completed

	Gauge	Thick
Tear Seal		
Bar Seal		
Bar Seal		

	No. of Feet
Tear Seal	
Bar Seal	
Bar Seal	

REQUIRES CUTTING OIL FOR PANELS

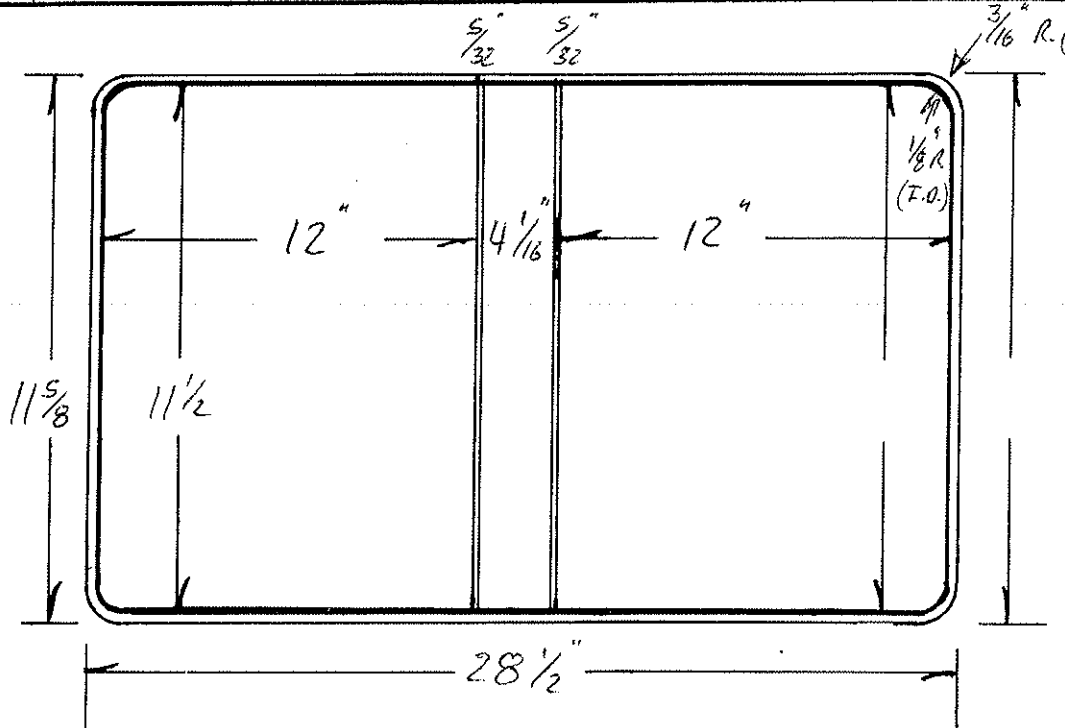

Code	Ga.	PCS	Cutting Specs		Code	Ga.	Pcs.	Cutting Specs	
			Size	Out				Size	Out
Cover Mat.		15	1		Lining Mat.		15	1	
Cover Mat					Lining Mat.				
Vert. Pckt.					Horz. Pckt.				
Vert. Pckt.					Horz. Pckt.	C.O.L.	8	1	
Pocket					Pocket				
Label Holder					Card Holder				
Material					Material				
Material					Material				
Material					Material				
F.C. Board		100	1		B.C. Board				
B.C. Board		100	1		B.B. Board		100	1	
Center Board					Board				
Board					Strip				
Cover Pad					Strip				
SKRIM					B.B. Pad				

Product Code

(89A) Style Case VRB

Sheet Size 11 X 9 Cap. 1/2

Die No. 4238

Order No. 962934

Plate

Customer VB&C

Metal
Total Vinyl
Quantity
Date
Type Corners
Radius
Completed

	Gauge	Thick
Tear Seal	008	3/32
Bar Seal	*178	3/16
Bar Seal		

	No. of Feet
Tear Seal	
Bar Seal	
Bar Seal	

F.C. PANEL REQUIRES CUTTING DIE

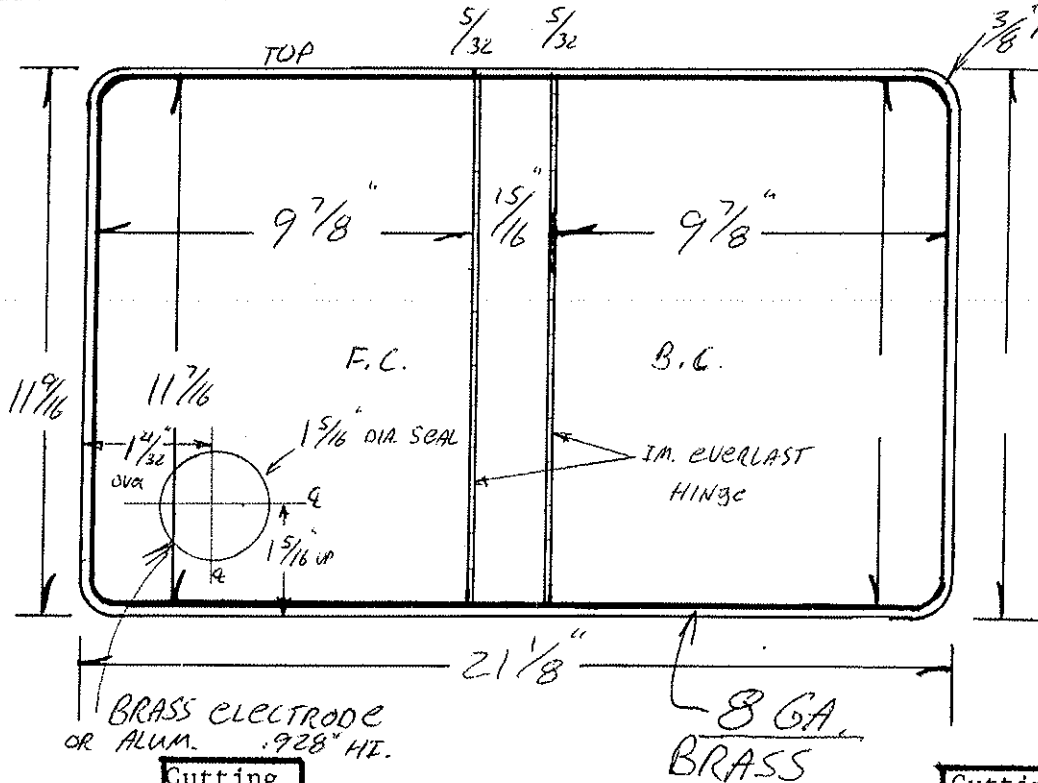

Code		Cutting Specs				Code		Cutting Specs			
		Ga.	#	Size	Out			Ga.	#	Size	Out
Cover Mat.	12 1/4 X 22	8	1			Lining Mat.	12 1/4 X 22	8	1		
Cover Mat.	X					Lining Mat.	X				
Vert. Pckt.	X					Horz. Pckt. FULL	5 3/8 X 22				
Vert. Pckt.	X					Horz. Pckt.	X				
Pocket	X					Pocket	X				
Label Holder	X					Card Holder	X				
Material	X					Material	X				
Material	X					Material	X				
Material	X					Material	X				
F.C. Board	11 1/32 X 9 25/32		1			B.C. Board	X				
B.C. Board	11 1/32 X 9 25/32		1			B.B. Board	11 1/32 X 27/32		1		
Center Board	X					Board	X				
Board	X					Strip	X				
Cover Pad	X					Strip	X				
						B.B. Pad	X				

Product Code

Style Case

VRB

Sheet Size $11\frac{3}{4} \times 9$

Cap. 3

Die No. 4253

Order No. 963170

Plate

Customer

JEBCO SEISMIC, INC.

Metal
Total Vinyl
Quantity 50
Date 7-30-89
Type Corners RND
Radius $\frac{3}{8}$ "
Completed

	Gauge	Thick
Tear Seal	.016"	$\frac{3}{32}$ "
Bar Seal	#254	$\frac{5}{32}$ "
Bar Seal		

	No. of Feet
Tear Seal	
Bar Seal	
Bar Seal	

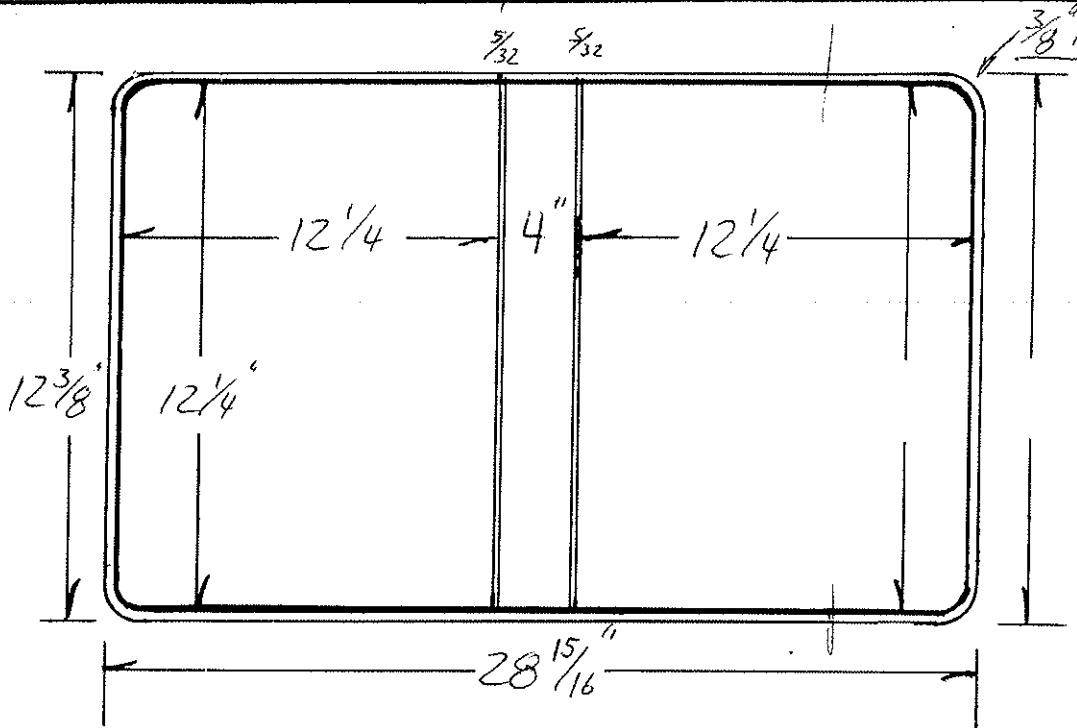

Code	Ga.	PCS	Cutting Specs		Code	Ga.	Pcs.	Cutting Specs	
			Size	Out				Size	Out
Cover Mat.		15			Lining Mat.		15		
		1					1		
Cover Mat.					Lining Mat.				
	X					X			
Vert. Pckt.					Horz. Pckt.				
	X					$5\frac{3}{8} \times 12\frac{3}{4}$			
Vert. Pckt.					Horz. Pckt.				
	X					$5\frac{3}{8} \times 29\frac{3}{4}$			
Pocket					Pocket				
	X					X			
Label Holder					Card Holder				
	X					X			
Material					Material				
	X					C.O.L. $12\frac{1}{2} \times 29\frac{3}{4}$	8	1	
Material					Material				
	X					X			
Material					Material				
	X					X			
F.C. Board					B.C. Board				
	$12\frac{5}{32} \times 12\frac{5}{32}$	120	1			X			
B.C. Board					B.B. Board				
	$12\frac{5}{32} \times 12\frac{5}{32}$	120	1			$12\frac{5}{32} \times 3\frac{29}{32}$	120	1	
Center Board					Board				
	X					X			
Board					Strip				
	X					X			
Cover Pad					Strip				
	X					X			
					B.B. Pad				
						X			

Product Code

OLD # 121

Style Case

VRB

Sheet Size

11 X 9 1/2 Cap. 2

Die No. 4267

Order No. 963309

Plate

Customer

SHARPE'S FORMAL WEAR

Metal
Total Vinyl
Quantity
Date 8-24-89
Type Corners
Radius 3/8"
Completed

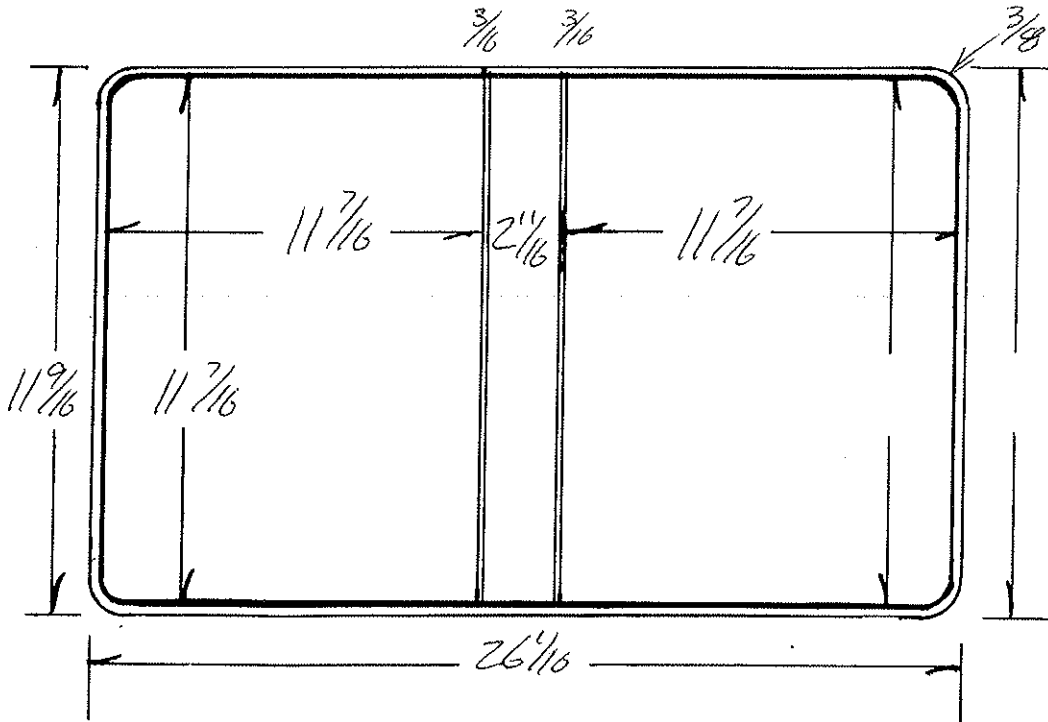

	Gauge	Thick
Tear Seal	016	3/32
Bar Seal	#178	3/16"
Bar Seal		

	No. of Feet
Tear Seal	
Bar Seal	
Bar Seal	

Code	Ga.	PCS	Cutting Specs		Code	Ga.	Pcs.	Cutting Specs	
			Size	Out				Size	Out
Cover Mat.		15	1		Lining Mat.		15	1	
Cover Mat.	PICT.	8	1		Lining Mat.				
Vert. Pckt.					Horz. Pckt.	1-510c	5 3/8	12	1
Vert. Pckt.					Horz. Pckt.	FULL	5 3/8	27	1
Pocket					Pocket				
Label Holder					Card Holder				
Material					Material				
Material					Material				
Material					Material				
F.C. Board		120	1		B.C. Board				
B.C. Board		120	1		B.B. Board		11 1/32 X 2 1/32	120	1
Center Board					Board				
Board					Strip				
Cover Pad					Strip				
					B.B. Pad				

OLD # 2286

Product Code

Style Case *VRB W/ICAV. & FILASTRA*

Sheet Size *11 X 9*

Cap. $\frac{1}{2}$ * Die No. *4360*

Order No.

Plate

Customer

NASCO

Metal
Total Vinyl
Quantity <i>100</i>
Date <i>1-9-90</i>
Type Corners
Radius <i>3/8</i>
Completed

	Gauge	Thick
Tear Seal	<i>014</i>	<i>1/16</i>
Bar Seal	<i>#254</i>	<i>3/32</i>
Bar Seal		

	No. of Feet
Tear Seal	
Bar Seal	
Bar Seal	

SIZE: *B. PACE.*
CHECK: *B.M.*

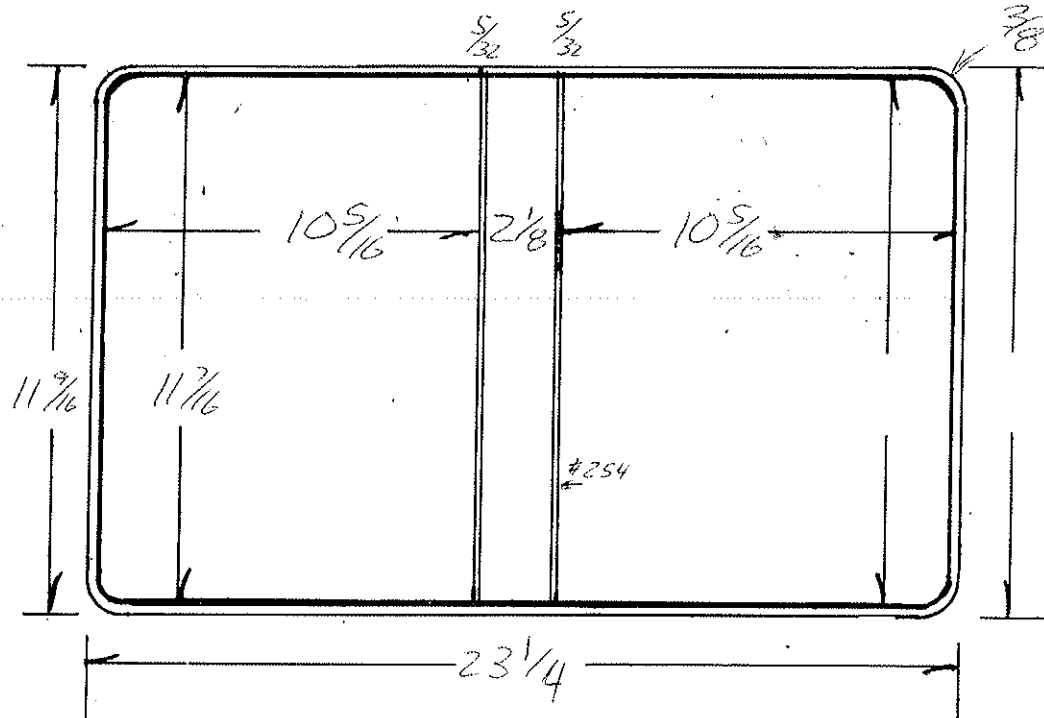

Code	Ga.	#	Cutting Specs		Code	Ga.	#	Cutting Specs	
			Size	Out				Size	Out
Cover Mat.			<i>12 1/4 X 24</i>	<i>15 1</i>	Lining Mat.			<i>12 1/4 X 24</i>	<i>15 1</i>
Cover Mat.			X		Lining Mat.			X	
Vert. Pckt.			X		Horz. Pckt.			<i>5 3/8 X 10 7/8</i>	
Vert. Pckt.			X		Horz. Pckt.			<i>5 3/8 X 24</i>	
Pocket			X		Pocket			X	
Label Holder			X		Card Holder			X	
Material			X		Material			X	
Material			X		Material			X	
Material			X		Material			X	
F.C. Board			<i>11 1/32 X 10 7/32</i>	<i>1</i>	B.C. Board			X	
B.C. Board			<i>11 1/32 X 10 7/32</i>	<i>1</i>	B.B. Board			<i>11 1/32 X 2 1/32</i>	<i>1</i>
Center Board			X		Board			X	
Board			X		Strip			X	
Cover Pad			X		Strip			X	
					B.B. Pad			X	

OLD# 3125

Style Case **VRB**

Product Code

Sheet Size **11** x **9 3/4** Cap. **1 1/2** Die No. **4413** Order No. **965163** Plate

WAGNER CODISPOTZ & CO.

Customer

Metal
Total Vinyl
Quantity 200
Date 4-26-90
Type Corners
Radius 3/8"
Completed

	Gauge	Thick
Tear Seal	.014	1/16"
Bar Seal	#258	5/32"
Bar Seal		

	No. of Feet
Tear Seal	
Bar Seal	
Bar Seal	

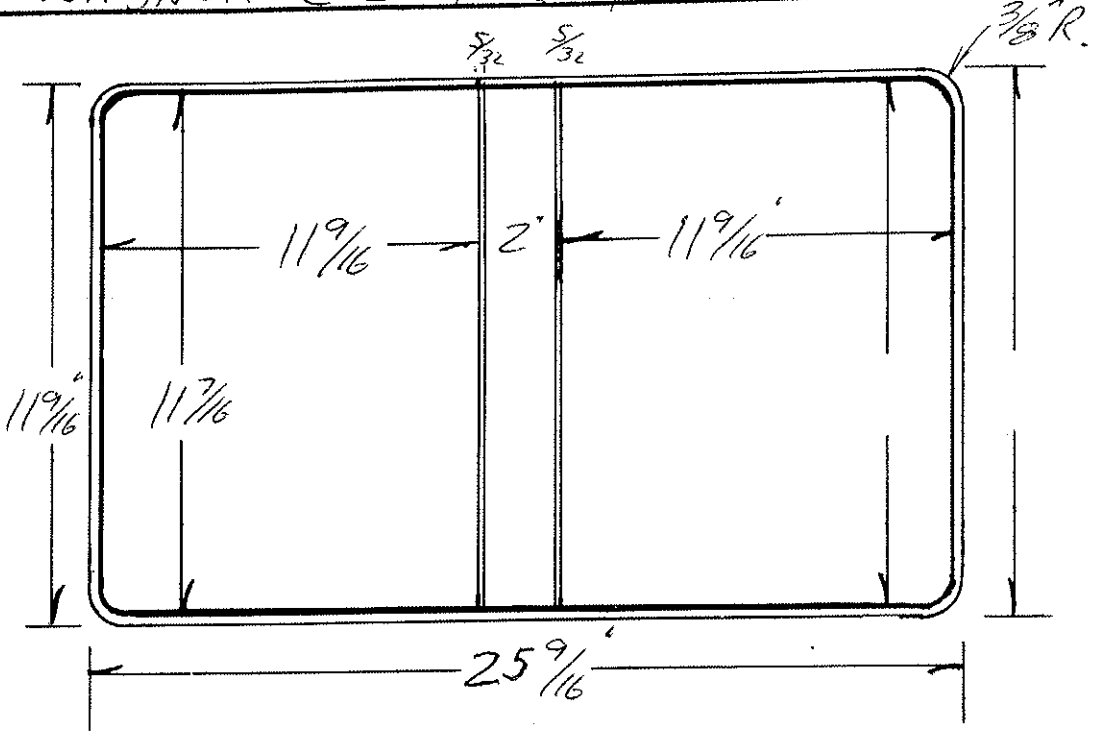

Size - **Bliss**
 Check - **KPV**

Code	Ga.	#	PCS	Cutting Specs		Code	Ga.	#	Pcs.	Cutting Specs	
				Size	Out					Size	Out
Cover Mat.						Lining Mat.					
Cover Mat. Padded						Lining Mat.					
Vert. Pckt.						Horz. Pckt.					
Vert. Pckt.						Horz. Pckt.					
Pocket						Pocket					
Label Holder						Card Holder					
Material						Material					
Material						Material					
Material						Material					
F.C. Board	STOCK 2 1/4"					B.C. Board					
B.C. Board	"					B.B. Board	STOCK 1 1/2"				
Center Board	FC-BL					Board	BB				
Board						Strip					
Cover Pad						Strip					
						B.B. Pad					
	Padded Bd. Die 4413 B										
	FC & BB Padded										
	12 1/2 x 14 3/4										

Product Code

Style Case **VRB**

Sheet Size **11 X 8 1/2** Cap. **1**

Die No. **4425**

Order No. **965465**

Plate

TEXAS CORPORATION SUPPLIES

Customer

Metal
Total Vinyl
Quantity
Date 5-10-90
Type Corners
Radius 3/8
Completed

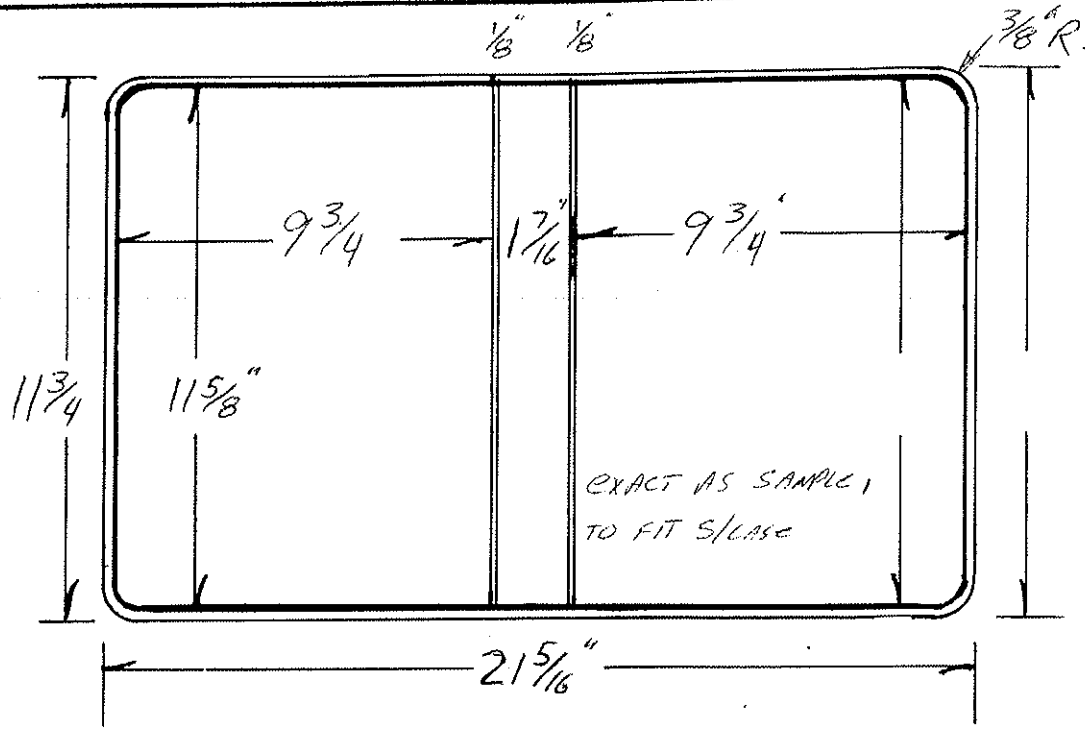

	Gauge	Thick
Tear Seal	2014	1/16"
Bar Seal	4253	1/8"
Bar Seal		

	No. of Feet
Tear Seal	
Bar Seal	
Bar Seal	

Size - **B. Pace**
 Check - **KPV**

Code	Ga.	# PCS	Cutting Specs		Code	Ga.	# PCS	Cutting Specs	
			Size	Out				Size	Out
Cover Mat.		12 1/2 X 22 1/8	15	1	Lining Mat.		12 1/2 X 22 1/8	15	1
Cover Mat		X			Lining Mat.		X		
Vert. Pckt.		X			Horz. Pckt.		5 3/8 X 22 1/8		
Vert. Pckt.		X			Horz. Pckt.		5 3/8 X 10 1/4	15	1
Pocket		X			Pocket		X		
Label Holder		X			Card Holder		X		
Material		X			Material		X		
Material		X			Material		X		
Material		X			Material		X		
F.C. Board		11 1/32 X 9 21/32	120	1	B.C. Board		11 9/16 X 9 1/16	100	1
B.C. Board		11 1/32 X 9 21/32	120	1	B.B. Board		11 9/16 X 1 1/32	100	1
Center Board		11 1/32 X 1 1/32	120	1	PC Board		11 9/16 X 9 1/16	100	1
Board		X			Strip		X		
Cover Pad		X			Strip		X		
					B.B. Pad		X		

Product Code

Style Case

Sheet Size 11 x 9

Cap. 1 1/2 D Die No. 4468

Order No. 965934

Plate

DATA GENERAL

Customer
Material
Total Vinyl
Quantity
Date
Type Corners
Radius
Completed

SEE ATTACHED DWG.

	Gauge	Thick
ear Seal		
lar Seal		1/8"
lar Seal		

	No. of Feet
ear Seal	
lar Seal	
lar Seal	

SIZE - B.P.M.C

CHECK - *HPV* calculations only

MADE BY ABLE OIE

ORDERS 7-18-90 AM FAX

CONF 7-16-90 AM B.P

PER SPEC. SHEET PER D.G.

Code	Ga.	# PCS	Cutting Specs		Code	Ga.	# Pcs.	Cutting Specs	
			Size	Out				Size	Out
Cover Mat.			12 1/4	25 3/4	Lining Mat.			12 1/4	25 3/4
Cover Mat.			X		Lining Mat.			X	
Int. Pckt.			X		Horz. Pckt.			5 3/8	25 3/4
Int. Pckt.			X		Horz. Pckt.			X	
Pocket			X		Pocket			X	
Label Holder			X		Card Hlder			X	
Material			X		Material			X	
Material			X		Material			X	
Material			X		Material			X	
B.C. Board			11 15/32	10 15/16	B.C. Board			X	
B.C. Board			11 15/32	10 15/16	B.B. Board			11 15/32	2 15/32
Center Board			X		Board			X	
Board			X		Strip			X	
Cover Pad			X		Strip			X	
					B.B. Pad			X	

Product Code

Style Case TRAPEZOID VRB

Sheet Size 11 x 9 Cap. 4"

Die No. 4479

Order No. 966025

Plate

Customer

AT&T

Metal
Total Vinyl
Quantity
Date
Type Corners
Radius
Completed

	Gauge	Thick
Tear Seal	.014	1/16"
Bar Seal	#254	5/16"
Bar Seal		

	No. of Feet
Tear Seal	
Bar Seal	
Bar Seal	

SIZE - B Plate

Check

KP ✓
calculations
only

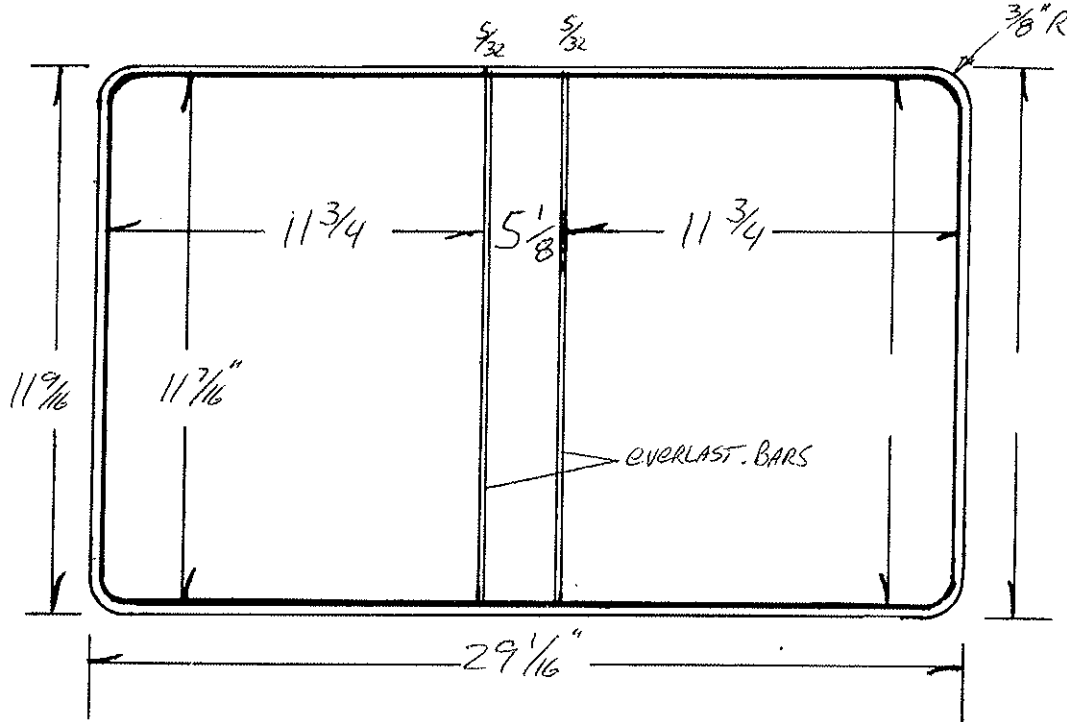

Code	Cutting Specs				Code	Cutting Specs			
	Ga.	# PCS	Size	Out		Ga.	# PCS	Size	Out
Cover Mat.			12 1/4 X 30		Lining Mat.			12 1/4 X 30	
Cover Mat.			X		Lining Mat.			X	
Vert. Pckt.			X		Horz. Pckt.			5 3/8 X 12 1/4	
Vert. Pckt.			X		Horz. Pckt.			5 3/8 X 30	
Pocket			X		Pocket			X	
Label Holder			X		Card Holder			X	
Material			X		Material			X	
Material			X		Material			X	
Material			X		Material			X	
F.C. Board			11 1/32 X 11 2/32	120 1	B.C. Board			X	
B.C. Board			11 1/32 X 11 2/32	120 1	B.B. Board			11 1/32 X 5 1/32	120 1
Center Board			X		Board			X	
Board			X		Strip			X	
Cover Pad			X		Strip			X	
					B.B. Pad			X	

Product Code

Style Case

Sheet Size 11 x 9 1/2 Cap. 1/2

Die No. 4509

Order No. 966186

Plate

Customer

ENGLISH COTTAGE

Material
Total Vinyl
Quantity
Plate
Type Corners
Radius
Completed

	Gauge	Thick
Ear Seal	.014	1/16
Ear Seal	473 HFT	1/32
Ear Seal		

	No. of Feet
Ear Seal	
Ear Seal	
Ear Seal	

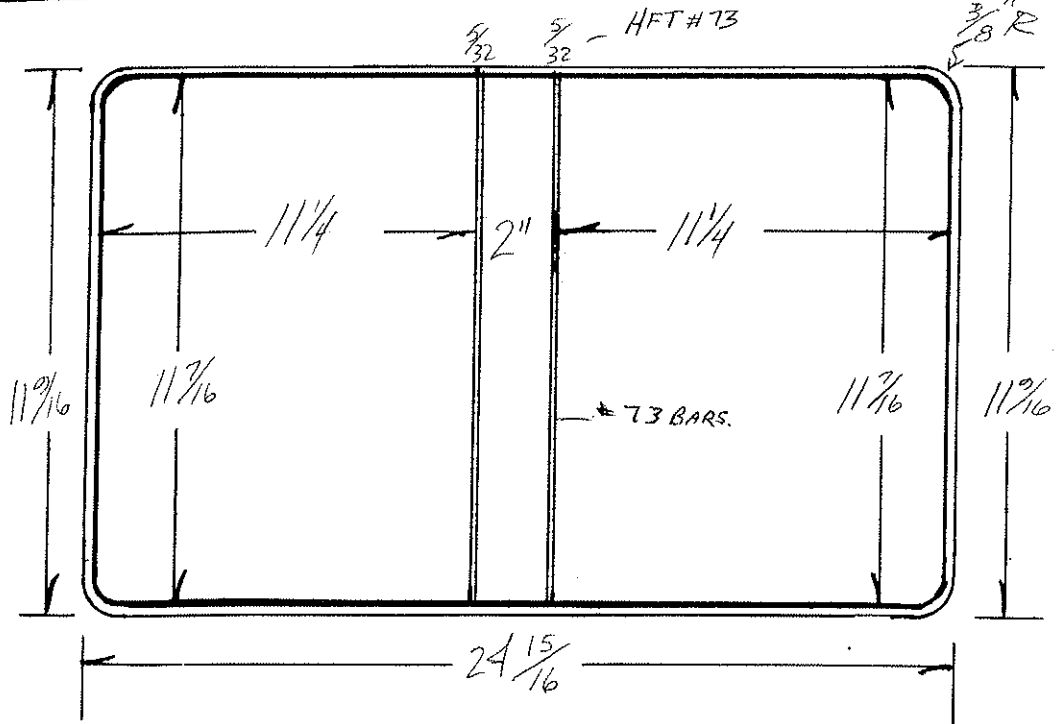

Designed by: J.P.
 Checked by: B.P.

Code	Ga.	# PCS	Cutting Specs		Code	Ga.	# Pcs.	Cutting Specs	
			Size	Out				Size	Out
Over Mat.		1	12 5/16 X 25 3/4		Lining Mat.	15	1	12 5/16 X 25 3/4	
Over Mat			X		Lining Mat.			X	
Int. Pckt.			X		Horz. Pckt.			5 3/8 X 11 3/4	
Int. Pckt.			X		Horz. Pckt.			5 3/8 X 25 3/4	
Pocket			X		Pocket			4 7/8 X 25 3/4	
Label Holder			X		Card Holder			X	
Material			X		Material			X	
Material			X		Material			X	
Material			X		Material			X	
B.C. Board		1	11 1/32 X 11 5/32	120	B.C. Board			X	
B.C. Board		1	11 1/32 X 11 5/32	120	B.B. Board	Pre-cut	1	11 1/32 X 1 29/32	120
Center Board		1	11 3/8 X 11 3/16	100	Board		1	11 3/8 X 1 15/16	100
Board		1	11 3/8 X 11 3/16	100	Strip			X	
Over Pad			X		Strip			X	
					B.B. Pad			X	

Product Code

Style Case *VRB W/CLIP I.B.C.*

Sheet Size *11* x *8 1/2* Cap. *1 1/2* ^{CLIP} Die No. *4553* Order No. *966770* Plate

SOUTH GEORGIA MEDICAL CENTER

Customer

Metal
Total Vinyl
Quantity <i>30</i>
Date <i>9-27-90</i>
Type Corners
Radius
Completed

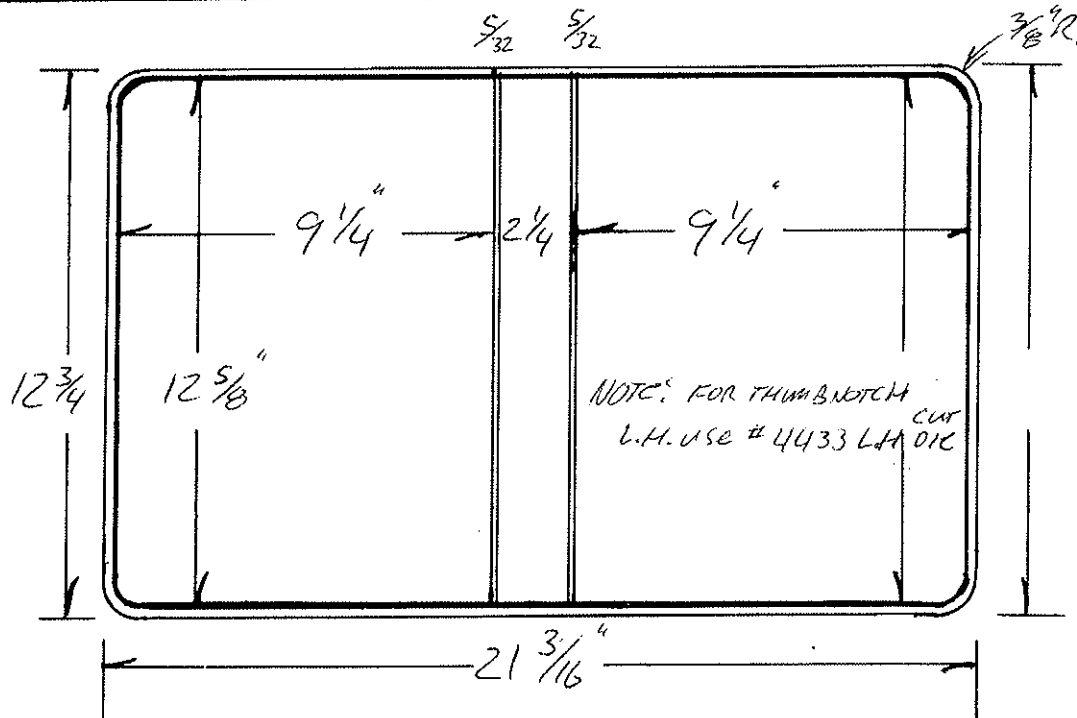

	Gauge	Thick
Tear Seal		
Bar Seal		
Bar Seal		

	No. of Feet
Tear Seal	
Bar Seal	
Bar Seal	

SIZE - B.P.
Check - SP
Calc only

Code	Ga.	# PCS	Cutting Specs		Code	Ga.	# PCS	Cutting Specs	
			Size	Out				Size	Out
Cover Mat.		<i>13 1/4</i> X <i>22</i>	<i>15</i>	<i>1</i>	Lining Mat.		<i>13 1/4</i> X <i>22</i>	<i>15</i>	<i>1</i>
Cover Mat		X			Lining Mat.		X		
Vert. Pckt.		X			Horz. Pckt.		<i>5 3/8</i> X <i>9 3/4</i>		
Vert. Pckt.		X			Horz. Pckt.		<i>5 7/8</i> X <i>22</i>	<i>15</i>	<i>1</i>
Pocket		X			Pocket		X		
Label Holder		<i>2 3/4</i> X <i>3 1/4</i>	<i>8</i>	<i>1</i>	Card Holder		X		
Material		X			Material		X		
Material		X			Material		X		
Material		X			Material		X		
F.C. Board		<i>12 1/32</i> X <i>9 5/32</i>	<i>100</i>	<i>1</i>	B.C. Board		X		
B.C. Board		<i>12 1/32</i> X <i>9 5/32</i>	<i>100</i>	<i>1</i>	B.B. Board		<i>12 1/32</i> X <i>2 5/32</i>	<i>100</i>	<i>1</i>
Center Board		X			Board		X		
Board		X			Strip		X		
Cover Pad		X			Strip		X		
					B.B. Pad		X		

2-Up Version Die # 4446-R
 Product Code

Style Case VRB 1 1/2" SQ. RING

Sheet Size 1 1/2 x 9 Cap. 1 1/2 sq Die No. 4575-R Order No. 966951 Plate C-7-41

IMPUL / NBA

Customer	
Metal	
Total Vinyl	
Quantity	?
Date	3-23-92
Type Corners	
Radius	3/8
Completed	

	Gauge	Thick
Tear Seal	.012	1/16
Bar Seal	48-4	5/32"
Bar Seal		

	No. of Feet
Tear Seal	
Bar Seal	
Bar Seal	

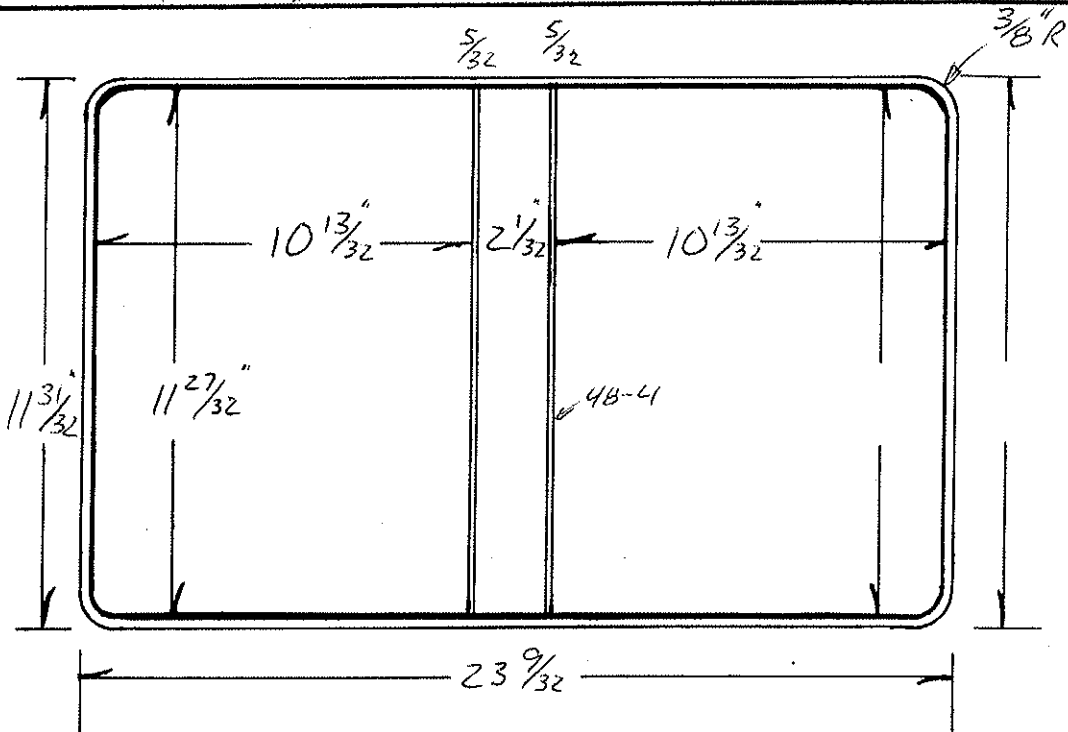

Dwy B. Pace
 CHECK.

CHANGED TO MATCH FIAB 4446-R
 3-23-92 PER BNF

DESTROY # 4575
 Code

	Ga.	# PCS	Cutting Specs		Code	Ga.	# Pcs.	Cutting Specs	
			Size	Out				Size	Out
Cover Mat.		1	12 3/4 X 24 1/8		Lining Mat.	1	12 3/4 X 24 1/8		
Cover Mat.			X		Lining Mat.		X		
Vert. Pckt.			X		Horz. Pckt.	1	5 3/8 X 10 7/8		
Vert. Pckt.			X		Horz. Pckt.	1	5 3/8 X 24 1/8		
Pocket			X		Pocket		X		
Label Holder			X		Card Hlder		X		
Material			X		Material		X		
Material			X		Material		X		
Material			X		Material		X		
F.C. Board		120	1	11 3/4 X 10 5/16	B.C. Board		X		
B.C. Board		120	1	11 3/4 X 10 5/16	B.B. Board	120	1	11 3/4 X 1 5/16	
Center Board				X	Board		X		
Board				X	Strip		X		
Cover Pad				X	Strip		X		
					B.B. Pad		X		

Product Code

ABLE

Style Case ^{NATURAL EDGE} NBA VRB PADD'D F.C. & B.B.

Sheet Size 11 1/2 x 9

Cap. 1 1/2 SQ. Die No. 4582-A

Order No. 967044

Plate

Customer

NBA

Metal
Total Vinyl
Quantity 48,000
Date 11-7-90
Type Corners
Radius 3/8"
Completed

see DWG.

MADE BY ABLE DIE CO

	Gauge	Thick
Tear Seal	NATURAL	1/8
Bar Seal	PLAIN	1/8
Bar Seal		

	No. of Feet
Tear Seal	
Bar Seal	
Bar Seal	

size - B.P.

CHECK - 

*NOTE: DIE #S 4582 A & B ARE SAME SIZE!

DIE # 4582 A HAS MTRL. SIZES FOR PADDING F.C. & B.B.

DIE # 4582 B HAS MTRL SIZE W/OUT PADDING.

Code		Cutting Specs				Code		Cutting Specs			
		Ga.	# PCS	Size	Out			Ga.	Pcs.	Size	Out
Cover Mat.	12 7/8 x 24 1/4	14	1			Lining Mat.	12 7/8 x 24	14	1		
Cover Mat	X					Lining Mat.	X				
Vert. Pckt.	X					Horz. Pckt. POLISH	5 3/8 x 11	8	1		
Vert. Pckt.	X					Horz. Pckt.	5 3/8 x 24				
Pocket	X					Pocket	X				
Label Holder	X					Card Hlder	X				
Material	X					Material	X				
Material	X					Material	X				
Material	X					Material	X				
F.C. Board PADD'D	11 23/32 x 10 9/32	120	1			B.C. Board	X				
B.C. Board	11 3/4 x 10 5/16	120	1			B.B. Board PADD'D	11 23/32 x 1 29/32	120	1		
Center Board	X					Board	X				
Board	X					Strip	X				
Cover Pad	X					Strip	X				
						B.B. Pad	X				

Product Code

SAME AS 2-UP 4643 ^{FLAB} Style Case

VRB

Sheet Size 11 X 9

Cap. 2' SQ.

Die No. 4643

Order No. 967635

Plate

Customer

EMPEL MKTG

Metal
Total Vinyl
Quantity 1,000
Date 3-21-91
Type Corners
Radius 3/4
Completed

	Gauge	Thick
Tear Seal		
Bar Seal		
Bar Seal		

	No. of Feet
Tear Seal	
Bar Seal	
Bar Seal	

Size - B.Pace

Check -

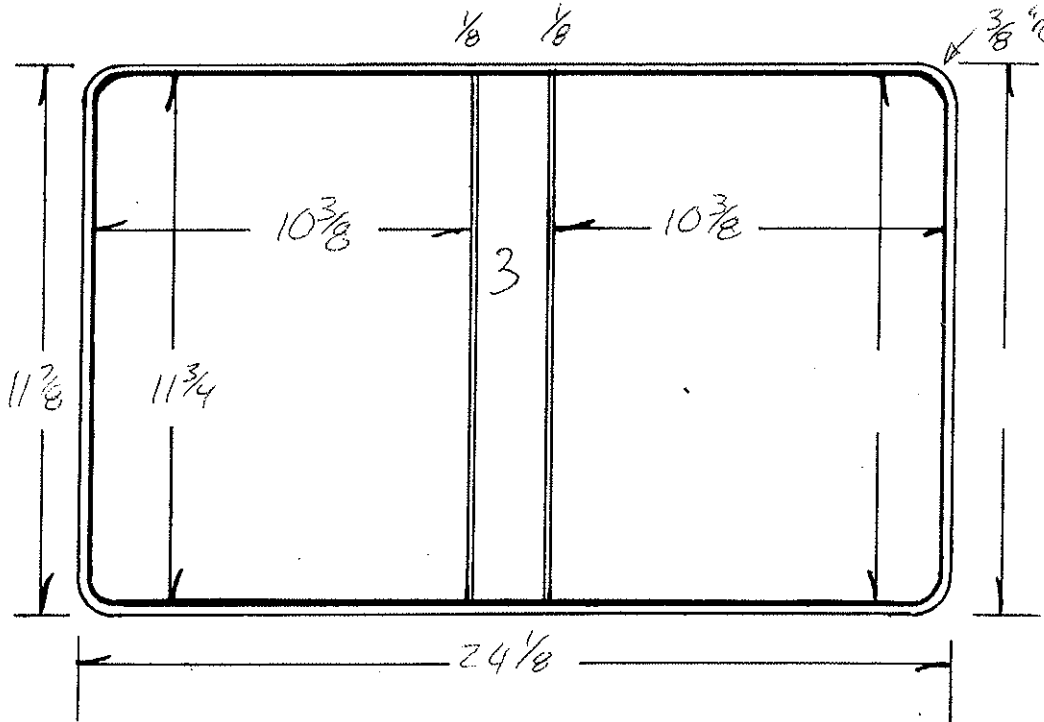

1 UP DIE MADE 2-20-91 FOR

SPOILAGE

Code	Description	Ga.	Pcs	Cutting Specs		Code	Description	Ga.	Pcs	Cutting Specs	
				Size	Out					Size	Out
Cover Mat.	12 5/8 X 25	15	1			Lining Mat.	12 5/8 X 25	15	1		
Cover Mat.	X					Lining Mat.	X				
Vert. Pckt.	X					Horz. Pckt.	5 3/8 X 10 7/8				
Vert. Pckt.	X					Horz. Pckt.	5 3/8 X 25				
Pocket	X					Pocket	X				
Label Holder	3 1/2 X 4	8	1			Card Holder	X				
Material	X					Material	X				
Material	X					Material	X				
Material	X					Material	X				
F.C. Board	11 21/32 X 10 9/32	120	1			B.C. Board	X				
B.C. Board	11 21/32 X 10 9/32	120	1			B.B. Board	11 21/32 X 2 29/32	120	1		
Center Board	X					Board	X				
Board	X					Strip	X				
Cover Pad	X					Strip	X				
						B.B. Pad	X				

Product Code

Style Case V.B. W/CLEAR FLAP I.B.C.

ACTUAL Sheet Size 11 5/16 X 8 7/8

Cap. 5/8 *

Die No. 4700

Order No. 968272

Plate C-13-3

HOLDEN LOOSELEAF

Customer	
Material	
Total Vinyl	
Quantity	500
Date	3-27-91
Type Corners	
Radius	1/8"
Completed	

	Gauge	Thick
ear Seal	0101	1/16
ear Seal	0102	1/16
ear Seal		

	No. of Feet
ear Seal	
ear Seal	
ear Seal	

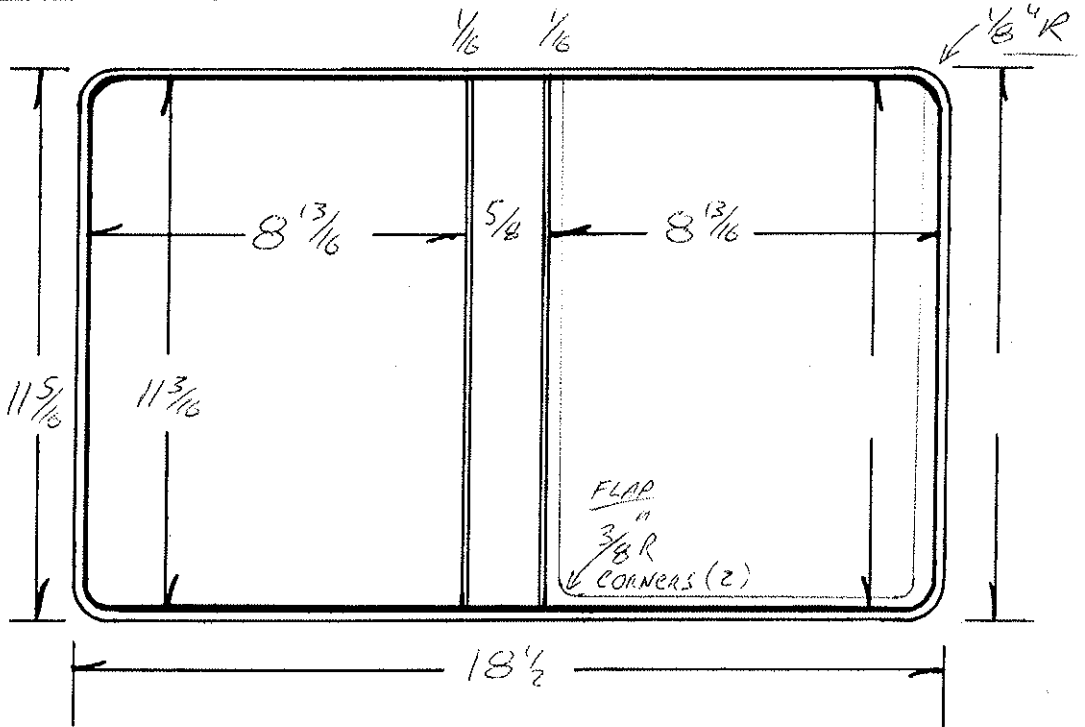

SIZE - B. Pass
MECH. *KPV*

Code	Ga.	# PCS	Cutting Specs		Code	Ga.	# Pcs.	Cutting Specs	
			Size	Out				Size	Out
Over Mat.		1	12 1/8 X 19 1/4		Lining Mat.		1	12 1/8 X 19 1/4	
Over Mat			X		Lining Mat.			X	
rt. Pckt.			X		Horz. Pckt.			5 3/8 X 9 3/8	
rt. Pckt.			X		Horz. Pckt.			5 3/8 X 19 1/4	
Pocket			X		Pocket			X	
Label Holder			X		Card Holder	ROUND CORNERS		X	
Material			X		Material	FLAP	1	11 5/8 X 8 3/8	
Material			X		Material	I.B.C.		X	
Material			X		Material			X	
C. Board		100	1	11 3/32 X 8 23/32	B.C. Board			X	
G. Board		100	1	11 3/32 X 8 23/32	B.B. Board		100	1	11 3/32 X 17 1/32
Water Board		100	2	11 1/8 X 8 3/4	Board			X	
Board		100	1	11 1/8 X 17 1/32	Strip			X	
Over Pad				X	Strip			X	
					B.B. Pad			X	

Product Code

Style Case VRB 1 1/4" memo

Sheet Size 11 X 9

Cap. 1 1/4" memo Die No. 4727

Order No. 968631

Plate

Customer

DELTA AIRLINES

Metal
Total Vinyl
Quantity <u>600</u>
Date <u>4-26-91</u>
Type Corners
Radius <u>3/8</u>
Completed

	Gauge	Thick
Tear Seal	<u>.014</u>	<u>1/16</u>
Bar Seal	<u>48-3</u>	<u>1/8</u>
Bar Seal		

	No. of Feet
Tear Seal	
Bar Seal	
Bar Seal	

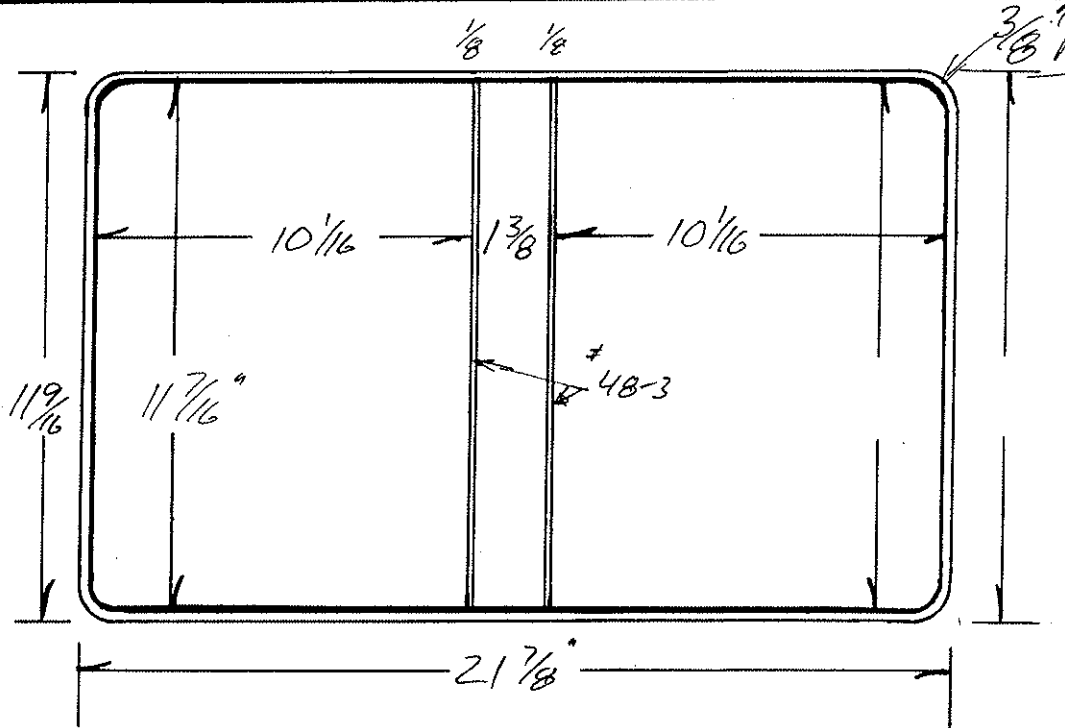

SIZE - D. Pace
 CHECK - VPV

PER SAMPLE

Code	Ga.	# PCS	Cutting Specs		Code	Ga.	# Pcs.	Cutting Specs	
			Size	Out				Size	Out
Cover Mat.		12 1/4 X 22 5/8	14	1	Lining Mat.		12 1/4 X 22 5/8	14	1
Cover Mat		X			Lining Mat.		X		
Vert. Pckt.		12 1/4 X 4 7/8	14	1	Horz. Pckt.		5 3/8 X 10 9/16		
Vert. Pckt.		X			Horz. Pckt.		5 3/8 X 22 5/8		
Pocket		X			Pocket		X		
Label Holder		X			Card Holder		X		
Material		X			Material		X		
Material		X			Material		X		
Material		X			Material		X		
F.C. Board	<u>RED</u>	11 1/32 X 9 3/32	36	1	B.C. Board		X		
B.C. Board	<u>FLEX</u>	11 1/32 X 9 3/32	36	1	B.B. Board		11 1/32 X 1 9/32	100	1
Center Board		X			Board		X		
Board		X			Strip		X		
Cover Pad		X			Strip		X		
					B.B. Pad		X		

Product Code

Style Case URB

Sheet Size 11 X 9

Cap. 3/4

Die No. 4789

Order No. 989162

Plate C-16

Customer

THE CREATIVE FACTORY

Metal
Total Vinyl
Quantity <u>500</u>
Date <u>6-10-91</u>
Type Corners
Radius <u>3/16"</u>
Completed

Gauge	Thick
Tear Seal <u>1014</u>	<u>1/16</u>
Bar Seal <u>#48-4</u>	<u>3/32</u>
Bar Seal	

No. of Feet
Tear Seal
Bar Seal
Bar Seal

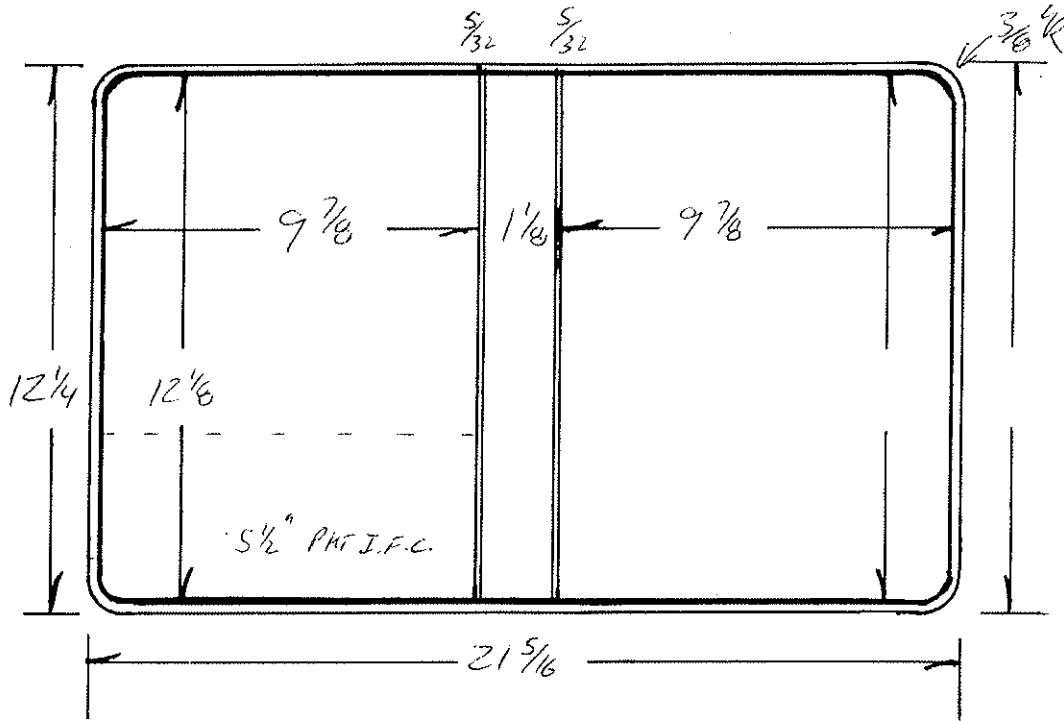

Dwg - B. Pace

Check - KPV

* USE DIE # 4790 - CALENDAR PKT.

* USE DIE # 3629 - CALENDAR COVER

* 11-3 3/4 L.O.C. I.B.C

Code	Ga.	PCS	Cutting Specs		Code	Ga.	Pcs.	Cutting Specs.	
			Size	Out				Size	Out
Cover Mat.			13 1/4	1	Lining Mat.			13	1
			X					X	
Vert. Pckt.			X		Horz. Pckct.			X	
Vert. Pckct.			X		Horz. Pckct. IFC			5 7/8 X 10 3/8	8 1
Pocket			X		Pocket Cal. Pkt.			3 1/4 X 4 1/8	8 1
Label Holder			X		Card Hlder			X	
Material			X		Material			X	
Material			X		Material			X	
Material			X		Material			X	
F.C. Board			12 1/32 X 9 25/32	120 1	B.C. Board			X	
B.G. Board			12 1/32 X 9 25/32	120 1	B.B. Board			12 1/32 X 1 1/32	120 1
Center Board			12 X 9 25/32	100 2	Board			3 1/2 X 2 1/4	134
Board			12 X 1 1/32	100 1	Strip			X	
Cover Pad			X		Strip			X	
					B.B. Pad			X	

