

Product Code

Style Case *VRB w/VHS TAY*

Sheet Size *11* x *9*

Cap. *2 1/4 Round* Die No. *4819*

Order No. *969463*

Plate *C-17-5*

SOUTHWEST PRINTERS & PUBLISHERS

8-7

Customer

Metal
Total Vinyl
Quantity <i>500</i>
Date <i>7-8-91</i>
Type Corners
Radius
Completed

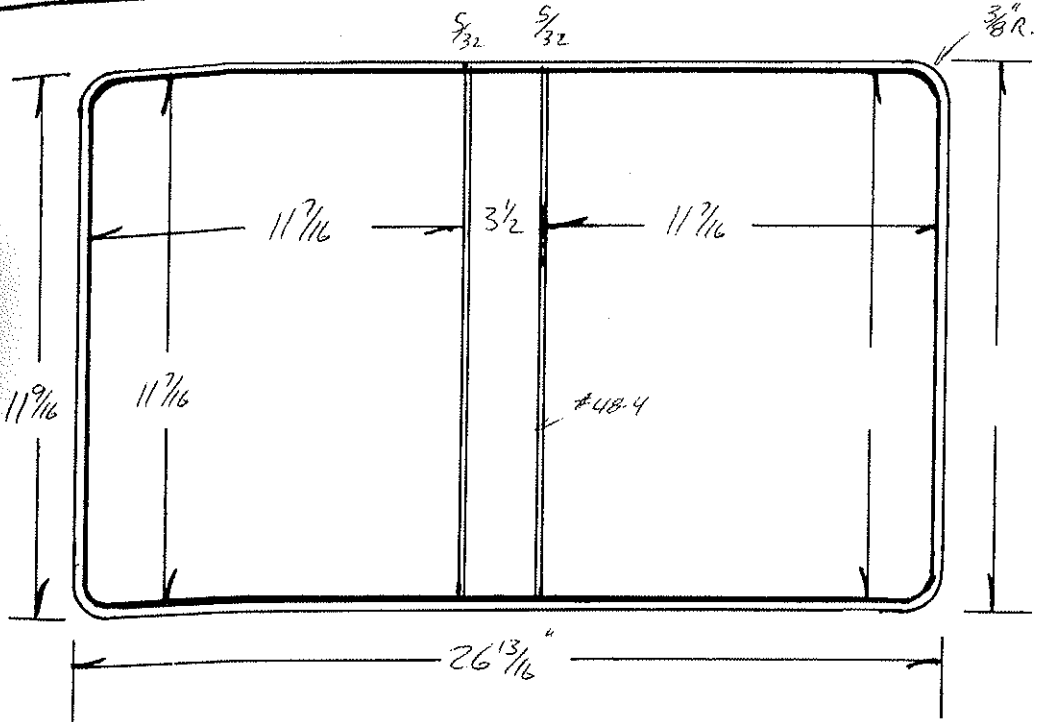

	Gauge	Thick
Tear Seal	<i>.014</i>	<i>1/16"</i>
Bar Seal	<i>#48-4</i>	<i>5/32</i>
Bar Seal		

	No. of Feet
Tear Seal	
Bar Seal	
Bar Seal	

Dubs - B. Price

CHECK. [Signature]

Code	Ga.	Pcs	Cutting Specs		Code	Ga.	Pcs.	Cutting Specs.	
			Size	Out				Size	Out
Cover Mat.			<i>12 1/4</i>	<i>X 27 5/8</i>	Lining Mat.			<i>12 1/4</i>	<i>X 27 5/8</i>
Cover Mat.				<i>X</i>	Lining Mat.				<i>X</i>
Vert. Pckt.				<i>X</i>	Horz. Pckt.			<i>5 3/8</i>	<i>X 12</i>
Vert. Pckt.				<i>X</i>	Horz. Pckt.			<i>5 3/8</i>	<i>X 27 5/8</i>
Pocket				<i>X</i>	Pocket				<i>X</i>
Label Holder				<i>X</i>	Card Hlder				<i>X</i>
Material <i>col.</i>			<i>11 1/16</i>	<i>X 16</i>	Material				<i>X</i>
Material				<i>X</i>	Material				<i>X</i>
Material				<i>X</i>	Material				<i>X</i>
F.C. Board			<i>11 1/32</i>	<i>X 11 1/32</i>	B.C. Board				<i>X</i>
B.C. Board			<i>11 1/32</i>	<i>X 11 1/32</i>	B.B. Board			<i>11 1/32</i>	<i>X 3 13/32</i>
Center Board				<i>X</i>	Board			<i>11 1/32</i>	<i>X 3 13/32</i>
Board				<i>X</i>	Strip				<i>X</i>
Cover Pad				<i>X</i>	Strip				<i>X</i>
					B.B. Pad				<i>X</i>

Product Code

Style Case VRB w/ VHS OR VB w/2-ZUPVH

Sheet Size 11 X 9

Cap. 1 1/2

Die No. 4885

Order No. 97018384

Plate C-19-3

TPFU

Customer	
Metal	11-3-1/2 LOC
Total Vinyl	
Quantity	250+250
Date	9-26-91
Type Corners	
Radius	3/8
Completed	

	Gauge	Thick
Tear Seal	.014	1/16
Bar Seal	#48-L1	5/32
Bar Seal		

	No. of Feet
Tear Seal	
Bar Seal	
Bar Seal	

DWS - B. Love
 Check - 

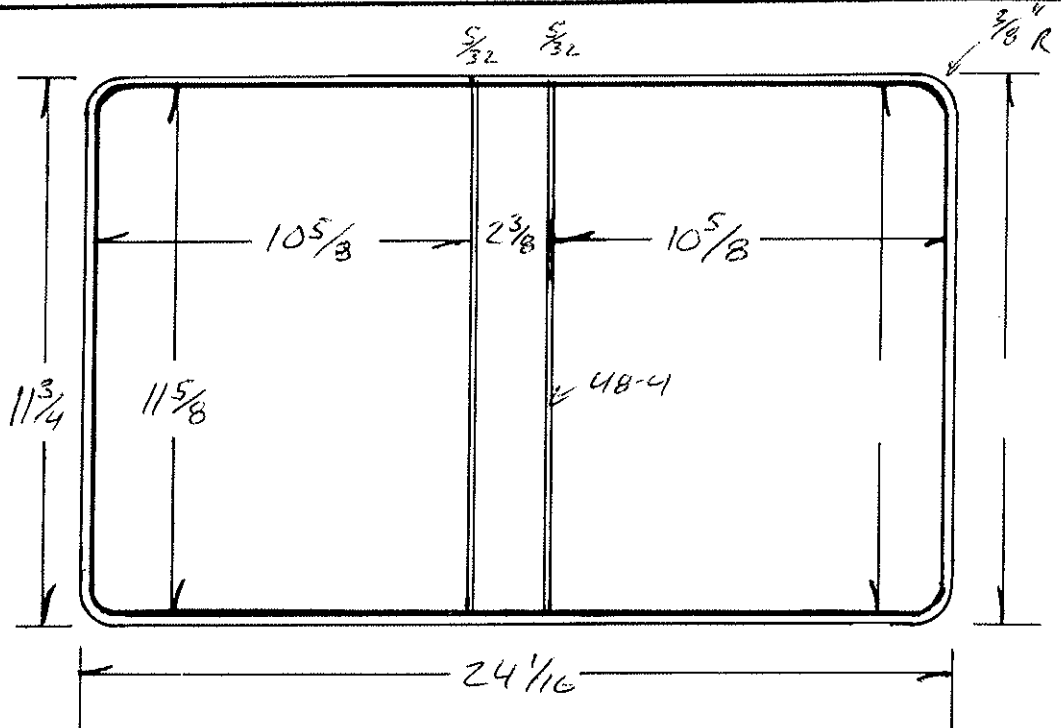

Code	MIN.	Ga.	PCS	Cutting Specs		Code	Ga.	Pcs.	Cutting Specs	
				Size	Out				Size	Out
Cover Mat.	12 1/4 X 24 7/8	14	1			Lining Mat.	12 1/4 X 24 7/8	14	1	
Cover Mat	X					Lining Mat.	X			
Vert. Pckt.	X					Horz. Pckt.	X			
Vert. Pckt.	X					Horz. Pckt.	X			
Pocket	X					Pocket	X			
Label Holder	X					Card Holder	X			
Material	X					Material	X			
Material	X					Material	X			
Material	X					Material	X			
F.C. Board	11 17/32 X 10 17/32	120	1			B.C. Board	X			
B.C. Board	11 17/32 X 10 17/32	120	1			B.B. Board	11 17/32 X 2 9/32	120	1	
Center Board	X					Board	X			
Board	X					Strip	X			
Cover Pad	X					Strip	X			
						B.B. Pad	X			

Product Code

Style Case *VRB*

Sheet Size *11 X 9 1/2* Cap. *2"*

Die No. *4891*

Order No. *969978*

Plate *C-19-*

Customer

SHELBY WILLIAMS IND. INC

Metal
Total Vinyl
Quantity <i>5,000</i>
Date <i>10-7-91</i>
Type Corners
Radius <i>3/8</i>
Completed

	Gauge	Thick
Tear Seal	<i>.014</i>	<i>Ø</i>
Bar Seal		
Bar Seal		

	No. of Feet
Tear Seal	
Bar Seal	
Bar Seal	

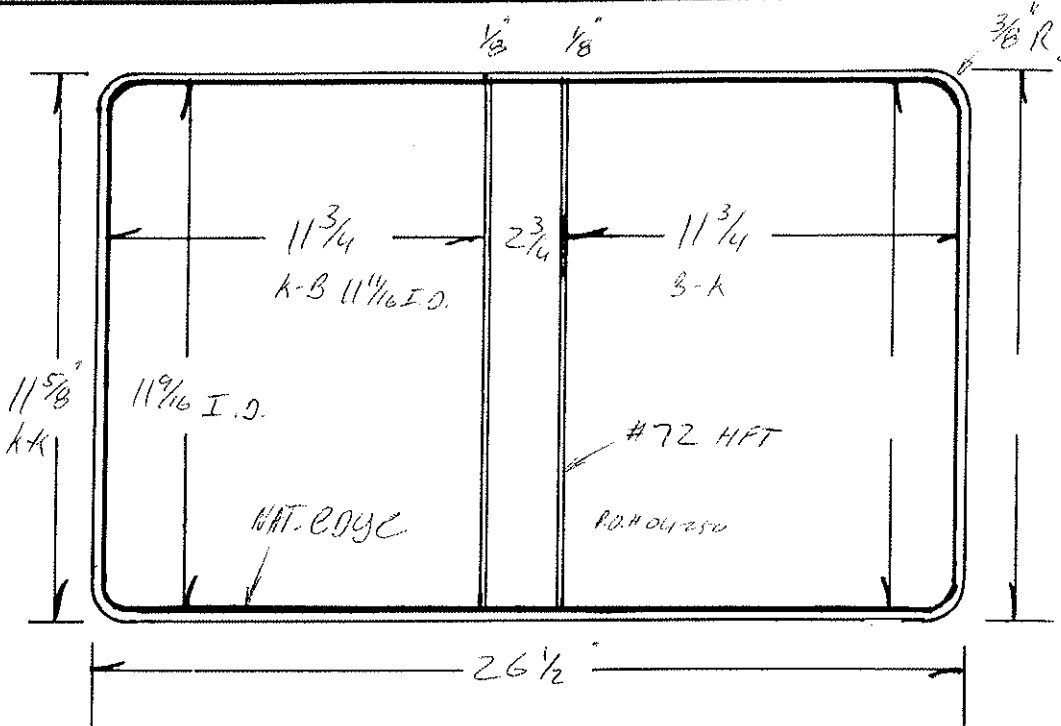

DWG - B. JACO
CHECK: (Signature)

PER SAMPLE

		Cutting Specs						Cutting Specs			
Code		Ga.	# PCS	Size	Out	Code		Ga.	# Pcs.	Size	Out
Cover Mat.	<i>12 1/4 X 27 1/4</i>	<i>14</i>	<i>1</i>			Lining Mat.	<i>12 1/4 X 27 1/4</i>	<i>14</i>	<i>1</i>		
Cover Mat	<i>X</i>					Lining Mat.	<i>X</i>				
Vert. Pckt.	<i>X</i>					Horz. Pckt.	<i>5 3/8 X 12 1/4</i>	<i>14</i>	<i>1</i>		
Vert. Pckt.	<i>X</i>					Horz. Pckt.	<i>X</i>				
Pocket	<i>X</i>					Pocket	<i>X</i>				
Label Holder	<i>X</i>					Card Holder	<i>3 X 4 3/8</i>	<i>8</i>	<i>1</i>		
Material <i>SARIM</i>	<i>11 3/8 X 4"</i>		<i>1</i>			Material	<i>X</i>				
Material	<i>X</i>					Material	<i>X</i>				
Material	<i>X</i>					Material	<i>X</i>				
F.C. Board	<i>11 1/2 X 11 5/8</i>	<i>120</i>	<i>1</i>			B.C. Board	<i>X</i>				
B.C. Board	<i>11 1/2 X 11 5/8</i>	<i>120</i>	<i>1</i>			B.B. Board	<i>11 1/2 X 2 5/8</i>	<i>120</i>	<i>1</i>		
Center Board	<i>X</i>					Board	<i>X</i>				
Board	<i>X</i>					Strip	<i>X</i>				
Cover Pad	<i>X</i>					Strip	<i>X</i>				
						B.B. Pad	<i>X</i>				

Product Code

Style Case VRB w/1" sq. kaoman

Sheet Size 11 1/4 x 9 5/8

Cap. 1 sq Die No. 4932

Order No. 970700

Plate D-2-1

Customer

IMPPELL MFG.

1-7-92

Metal	11-3-1 sq. kaoman
Total Vinyl	
Quantity	12-5-91
Date	5,000
Type Corners	
Radius	
Completed	

	Gauge	Thick
Tear Seal	.014	1/16
Bar Seal	*253	1/8"
Bar Seal		

	No. of Feet
Tear Seal	
Bar Seal	
Bar Seal	

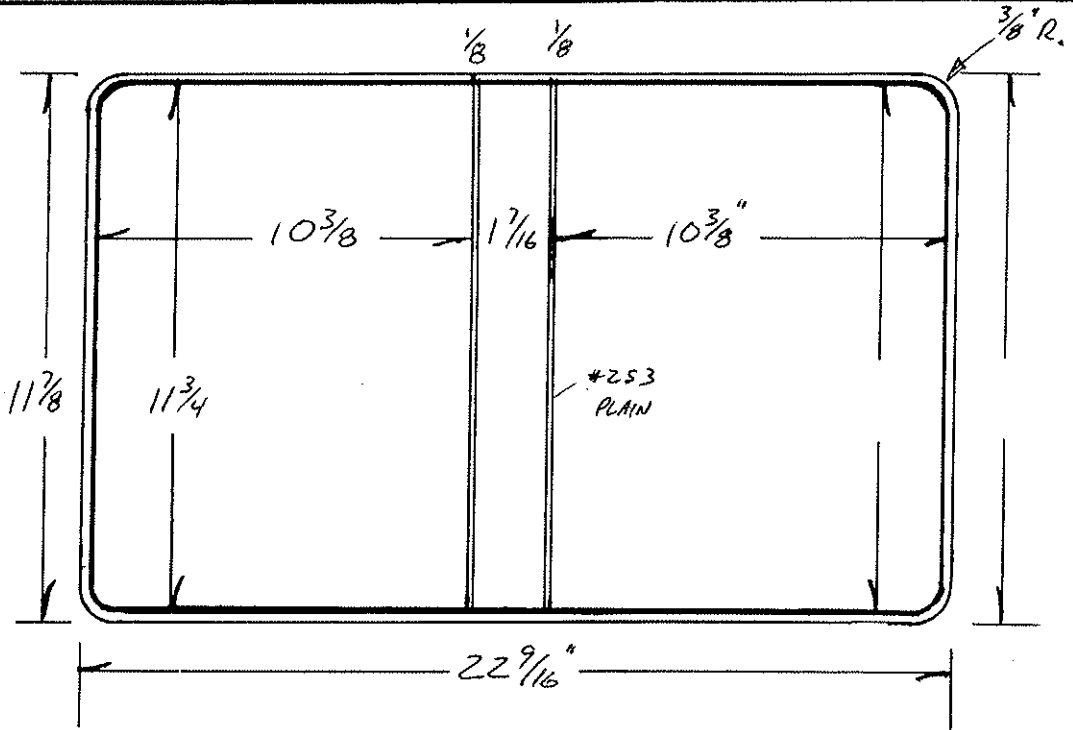

DWG - B. Free
 Check - *(Signature)*

ACTUAL SHEET SIZE = 11 1/4 x 9 5/8 w/1" sq.

Code	Ga.	# PCS	Cutting Specs		Code	Ga.	# Pcs.	Cutting Specs	
			Size	Out				Size	Out
Cover Mat.		14	1		Lining Mat.		14	1	
Cover Mat.					Lining Mat.				
Vert. Pckt.					Horz. Pckt.				
Vert. Pckt.					Horz. Pckt.				
Pocket					Pocket				
Label Holder					Card Holder				
Material					Material				
Material					Material				
Material					Material				
F.C. Board		100	1		B.C. Board				
B.C. Board		100	1		B.B. Board		100	1	
Center Board					Board				
Board					Strip				
Cover Pad					Strip				
					B.B. Pad				

Product Code

Style Case *ORB C.O.C. 11-3-3 OVAL*

Sheet Size *11 X 9 3/4* Cap. *3 OVAL*

Die No. *4940*

Order No. *970864*

Plate *D-2-4*

Customer

SOUTHERN COMPANY SERVICES

12-27

Metal
Total Vinyl
Quantity <i>410</i>
Date <i>12-18-91</i>
Type Corners
Radius
Completed

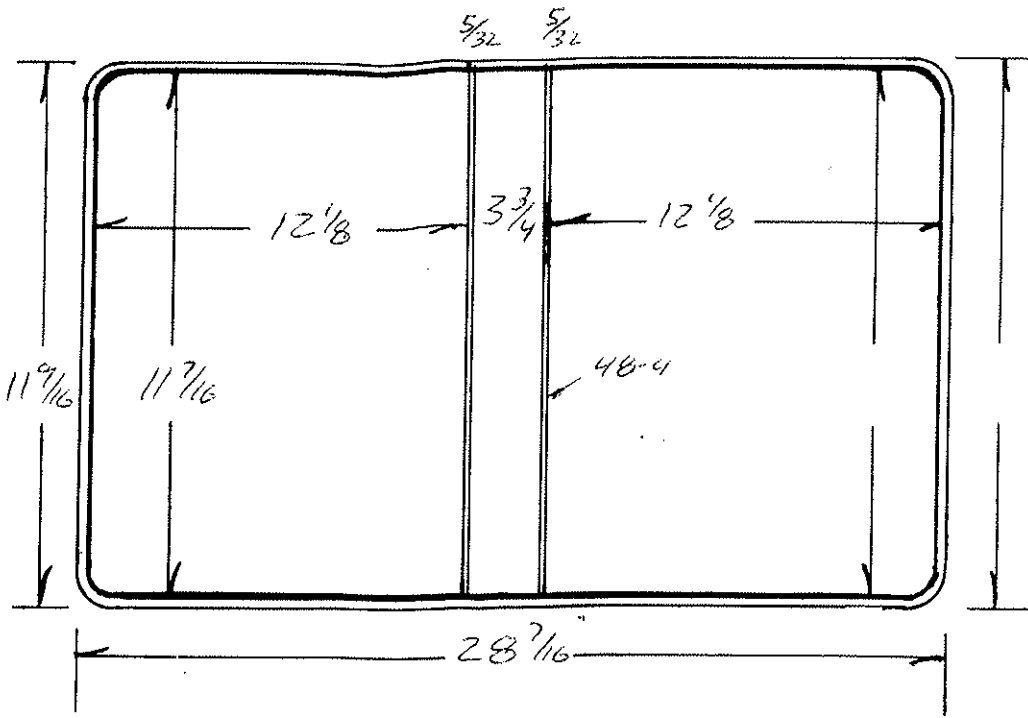

	Gauge	Thick
Tear Seal	<i>.014</i>	$\frac{1}{16}$
Bar Seal	<i>.48-4</i>	$\frac{5}{32}$
Bar Seal		

	No. of Feet
Tear Seal	
Bar Seal	
Bar Seal	

OWS - B.P.M.
CHEN - RAV

C.O.C. SIZES
FC & BC 11 7/16 X 11 13/16
BB 11 1/16 X 3 7/16

	Code	Cutting Specs				Code	Cutting Specs				
		Ga.	PCS	Size	Out		Ga.	PCS	Size	Out	
Cover Mat.		$12 \frac{1}{4}$	1	$29 \frac{1}{4}$		Lining Mat.		$12 \frac{1}{4}$	1	$29 \frac{1}{4}$	
Cover Mat.	X					Lining Mat.	X				
Vert. Pckt.	X					Horz. Pckt. <i>FC + BC</i>	$5 \frac{3}{8}$	1	$29 \frac{1}{4}$		
Vert. Pckt.	X					Horz. Pckt.	X				
Pocket	X					Pocket	X				
Label Holder	X					Card Holder	X				
Material	<i>C.O.C. 11 7/16 X 29 1/4</i>	8	1			Material	X				
Material	X					Material	X				
Material	X					Material	X				
F.C. Board		$11 \frac{1}{32}$	1	$12 \frac{1}{32}$		B.C. Board	X				
B.C. Board		$11 \frac{1}{32}$	1	$12 \frac{1}{32}$		B.B. Board		$11 \frac{1}{32}$	1	$3 \frac{21}{32}$	
Center Board	X					Board	<i>BACK-UP</i>	$11 \frac{1}{32}$	1	$3 \frac{21}{32}$	
Board	X					Strip	X				
Cover Pad	X					Strip	X				
						B.B. Pad	X				

Product Code

Style Case

VRB

2-up Fiab # 49

Sheet Size

11 X 9 3/4 * Cap. 3/4" Loc. * Die No. 4971

Order No.

971086

Plate D-3-6

Customer

EDUCATIONAL REVIEW

1-24

Metal	11-3-3/4 LOC.
Total Vinyl	
Quantity	
Date	1-20-92
Type Corners	
Radius	
Completed	

	Gauge	Thick
Tear Seal	.014	1/16
Bar Seal	48-4	5/32
Bar Seal		

	No. of Feet
Tear Seal	
Bar Seal	
Bar Seal	

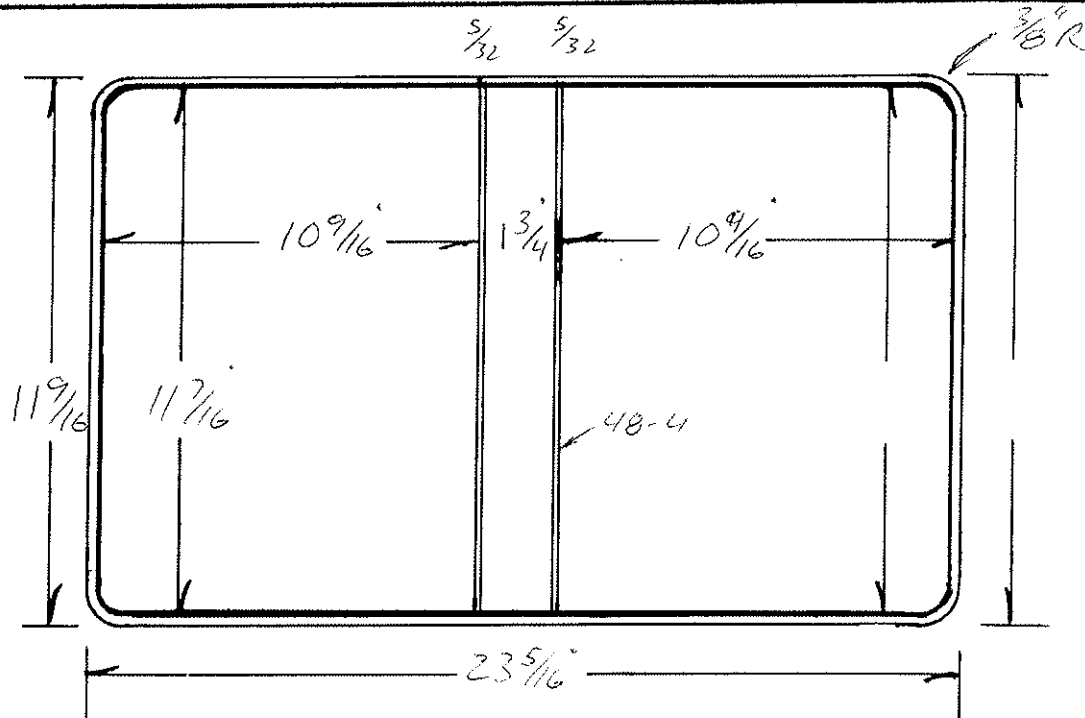

Dwy. B. Pac

CHECK

*
STEEL 1/2" PANELS
" 1/4" B.B.

ACTUAL SHEET
SIZE = 11 X 9 3/4

Code	(w/3/4" normal)	Ga.	PCS	Cutting Specs		Code	Ga.	Pcs.	Cutting Specs	
				Size	Out				Size	Out
Cover Mat.	12 1/4 X 24 1/2	14	1			Lining Mat.	12 1/4 X 24 1/2	14	1	
Cover Mat	X					Lining Mat.	X			
Vert. Pckt.	X					Horz. Pckt.	5 3/8 X 11 1/4			
Vert. Pckt.	X					Horz. Pckt.	X			
Pocket	X					Pocket	X			
Label Holder	X					Card Holder	X			
Material	X					Material	X			
Material	X					Material	X			
Material	X					Material	X			
F.C. Board	PRE- 11 3/8 X 10 1/2	100	1			B.C. Board	X			
B.C. Board	CUT 11 3/8 X 10 1/2	100	1			B.B. Board	11 3/8 X 1 2/32	100	1	
Center Board	(1 1/2)	X				Board	X			
Board	X					Strip	X			
Cover Pad	X					Strip	X			
						B.B. Pad	X			

Product Code

Style Case *VRB*

Sheet Size **11* X *9*

Cap. *1 1/2*

Die No. *4990*

Order No. *971181*

Plate *D-4-2*

Customer

MARKAIR

2-21

Metal
Total Vinyl
Quantity <i>100</i>
Date <i>2-13-92</i>
Type Corners
Radius <i>3/8</i>
Completed

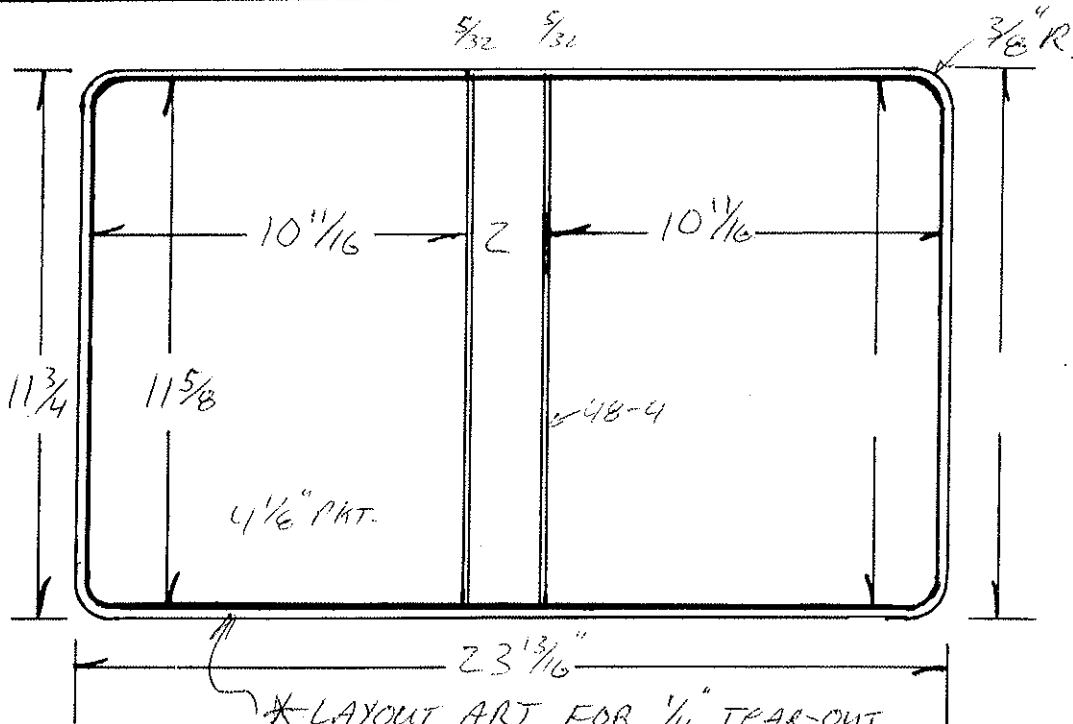

	Gauge	Thick
Tear Seal	<i>.014</i>	<i>1/16</i>
Bar Seal	<i>48-4</i>	<i>3/32</i>
Bar Seal		

	No. of Feet
Tear Seal	
Bar Seal	
Bar Seal	

DWG. B. FACE

CHECK

(Signature)

PER SAMPLE

		Cutting Specs						Cutting Specs			
Code		Ga.	PCS	Size	Out	Code		Ga.	Pcs.	Size	Out
Cover Mat.	<i>12 1/4 X 24 5/8</i>		<i>1</i>			Lining Mat.	<i>12 1/4 X 24 5/8</i>		<i>1</i>		
Cover Mat.	<i>X</i>					Lining Mat.	<i>X</i>				
Vert. Pckt.	<i>X</i>					Horz. Pckt.	<i>X</i>				
Vert. Pckt.	<i>X</i>					Horz. Pckt. <i>FROSTED</i>	<i>4 1/2 X 24 5/8</i>	<i>8</i>	<i>1</i>		
Pocket	<i>X</i>					Pocket	<i>X</i>				
Label Holder	<i>X</i>					Card Holder	<i>X</i>				
Material	<i>X</i>					Material	<i>X</i>				
Material	<i>X</i>					Material	<i>X</i>				
Material	<i>X</i>					Material	<i>X</i>				
F.C. Board	<i>11 9/16 X 10 5/8</i>	<i>100</i>	<i>1</i>			B.C. Board	<i>X</i>				
B.C. Board	<i>11 9/16 X 10 5/8</i>	<i>100</i>	<i>1</i>			B.B. Board	<i>11 9/16 X 12 9/32</i>	<i>100</i>	<i>1</i>		
Center Board	<i>X</i>					Board	<i>X</i>				
Board	<i>X</i>					Strip	<i>X</i>				
Cover Pad	<i>X</i>					Strip	<i>X</i>				
						B.B. Pad	<i>X</i>				

Product Code L.H. Loading Tray # 5043

Style Case VRB same as 5014 ^{1 3/4} _{1 3/4}

Sheet Size 11 X 8 1/2 Cap. 1 1/4 Die No. 4993B Order No. 971448 Plate D-4-

Customer

EMPIRE CORPORATE KITS

2-27 U-

Metal
Total Vinyl
Quantity <u>6 - 61k</u>
Date <u>2-20-91</u>
Type Corners
Radius <u>3/8"</u>
Completed

	Gauge	Thick
Tear Seal	<u>.014</u>	<u>1/16</u>
Bar Seal	<u>253</u>	<u>1/8</u>
Bar Seal		

	No. of Feet
Tear Seal	
Bar Seal	
Bar Seal	

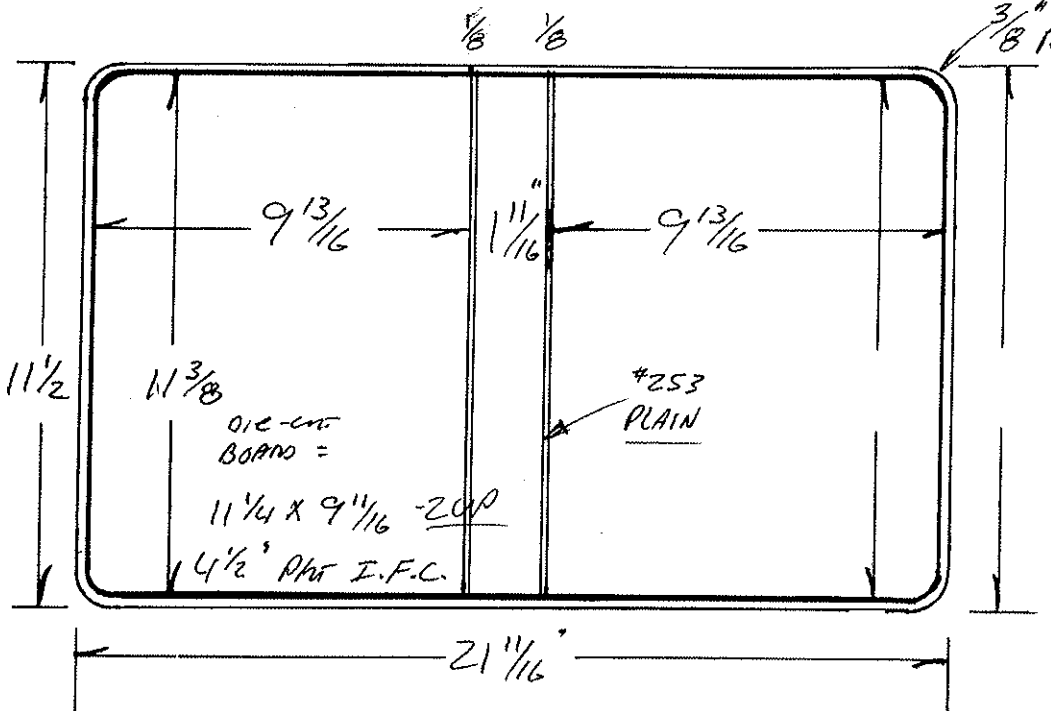

Dwg. - B. Price
CHECK - VP

SEE 4993-3 →
LABEL HOLDER

PER SAMPLE

Code	Ga.	PCS	Cutting Specs		Code	Ga.	Pcs.	Cutting Specs	
			Size	Out				Size	Out
Cover Mat.		1	12 1/4 X	22 1/2	Lining Mat.		1	12 1/4 X	22 1/2
Cover Mat. Padded			12 1/2 X	22 3/4	Lining Mat.			X	
Vert. Pckt.			X		Horz. Pckt.			X	
Vert. Pckt.			X		Horz. Pckt. 4 1/2"		1	4 7/8 X	10 5/16
Pocket			X		Pocket I.F.C.			X	
Label Holder		8	7 1/16 X	13 1/16"	Card Holder			X	
Material PULL-TAG		1	2 1/8 X	1 1/4	Material			X	
Material			X		Material			X	
Material			X		Material			X	
F.C. Board			X		B.C. Board			X	
B.C. Board			X		B.B. Board		100	11 9/32 X	1 19/32
Center Board Padded			X		Board			X	
Board PRE-		100	11 9/32 X	9 23/32	Strip			X	
Cover Pad CUT		100	11 9/32 X	9 23/32	Strip			X	
					B.B. Pad			X	

Product Code

Style Case VRB

Sheet Size 11 X 8 1/2 Cap. 1 1/4 Die No 5014 AND Order No. 971448 Plate D-5-5

Customer EMPIRE CORPORATE KITS 3-12-92

Customer
Metal
Total Vinyl
Quantity <u>6 + 61K</u>
Date <u>3-10-92</u>
Type Corners
Radius <u>3/8</u>
Completed

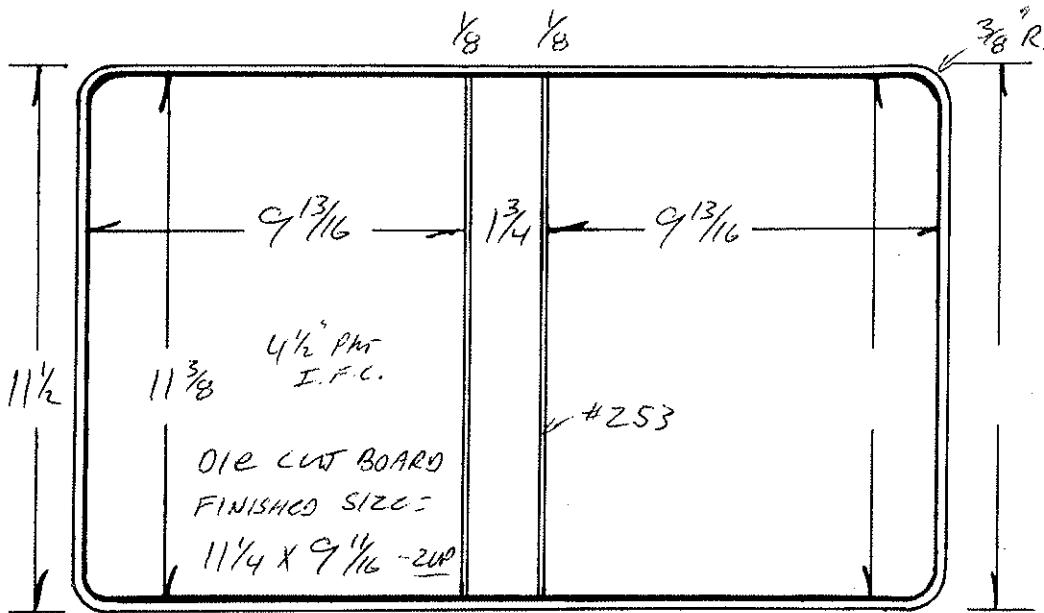

Gauge	Thick
Tear Seal <u>014</u>	<u>1/16"</u>
Bar Seal <u>253</u>	<u>1/8"</u>
Bar Seal	

No. of Feet	
Tear Seal	
Bar Seal	
Bar Seal	

Dwg. B. Pace

Check. KPV

* SAME AS #4993 EXC. 1 1/16" SPINE

* USE LABEL HOLDER # 4993-B @ U-7

Code		Ga.	#	PCS	Size	Out	Cutting Specs	Code		Ga.	#	PCS	Size	Out	Cutting Specs
Cover Mat.				14	1			Lining Mat.				14	1		
Cover Mat								Lining Mat.							
Vert. Pckt.								Horz. Pckt.							
Vert. Pckt.								Horz. Pckt.	<u>4 1/2"</u>				<u>4 7/8 X 10 5/16</u>		<u>1</u>
Pocket								Pocket							
Label Holder				8	1			Card Holder							
Material	<u>PULL - TAB</u>							Material							
Material								Material							
Material								Material							
F.C. Board								B.C. Board							
B.C. Board								B.B. Board					<u>11 7/32 X 1 19/32</u>	<u>100</u>	<u>1</u>
Center Board	<u>PROCES</u>							Board							
Board	<u>ORCL</u>							Strip							
Cover Pad								Strip							
								B.B. Pad							

Product Code

Style Case *VRB*

* Sheet Size * *11* x *9*

Cap. * *2* + *WIS* Die No. *5018*

Order No. *971674*

Plate *0-5-8*

Customer

CHRISTIAN INT'L.

3-30

Metal
Total Vinyl
Quantity <i>250</i>
Date <i>3-16-97</i>
Type Corners
Radius <i>3/8"</i>
Completed

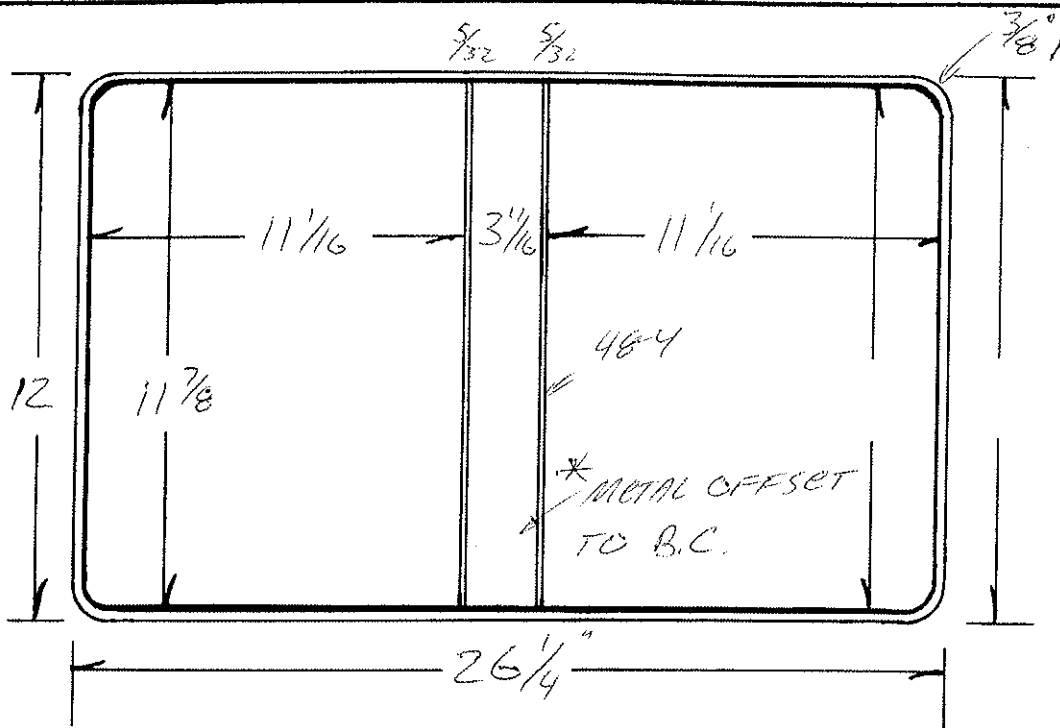

	Gauge	Thick
Tear Seal	<i>1014</i>	<i>1/16</i>
Bar Seal	<i>48-4</i>	<i>5/32</i>
Bar Seal		

	No. of Feet
Tear Seal	
Bar Seal	
Bar Seal	

Dwg. - B.Face
check -

SIZES PER CUSTOMER'S C.O.L. INSERT
SAMPLES

Code	Ga.	Pcs	Cutting Specs		Code	Ga.	Pcs	Cutting Specs	
			Size	Out				Size	Out
Cover Mat.		<i>12 3/4</i> x <i>27"</i>	<i>14</i>	<i>1</i>	Lining Mat.		<i>12 3/4</i> x <i>27"</i>	<i>14</i>	<i>1</i>
Cover Mat.		X			Lining Mat.		X		
Vert. Pckt.		X			Horz. Pckt.		X		
Vert. Pckt.		X			Horz. Pckt.		X		
Pocket		X			Pocket		X		
Label Holder		X			Card Holder		X		
Material	<i>c.o.l.</i>	<i>12 1/8</i> x <i>27</i>	<i>8</i>	<i>1</i>	Material		X		
Material		X			Material		X		
Material		X			Material		X		
F.C. Board		<i>11 25/32</i> x <i>10 3/32</i>	<i>120</i>	<i>1</i>	B.C. Board		X		
B.C. Board		<i>11 25/32</i> x <i>10 3/32</i>	<i>120</i>	<i>1</i>	B.B. Board		<i>11 25/32</i> x <i>3 19/32</i>	<i>100</i>	<i>1</i>
Center Board		X			Board		<i>11 25/32</i> x <i>3 19/32</i>	<i>22</i>	<i>1</i>
Board		X			Strip		X		
Cover Pad		X			Strip		X		
					B.B. Pad		X		

Product Code

Style Case *V QCV CLI. METAL*

Sheet Size *11 X 9*

Cap. *2*

Die No. *5042*

Order No. *971881*

Plate *D-7-1*

Customer

VULCAN ENGINEERING CO.

4-

Metal
Total Vinyl
Quantity
Date <i>4-20-92</i>
Type Corners
Radius
Completed

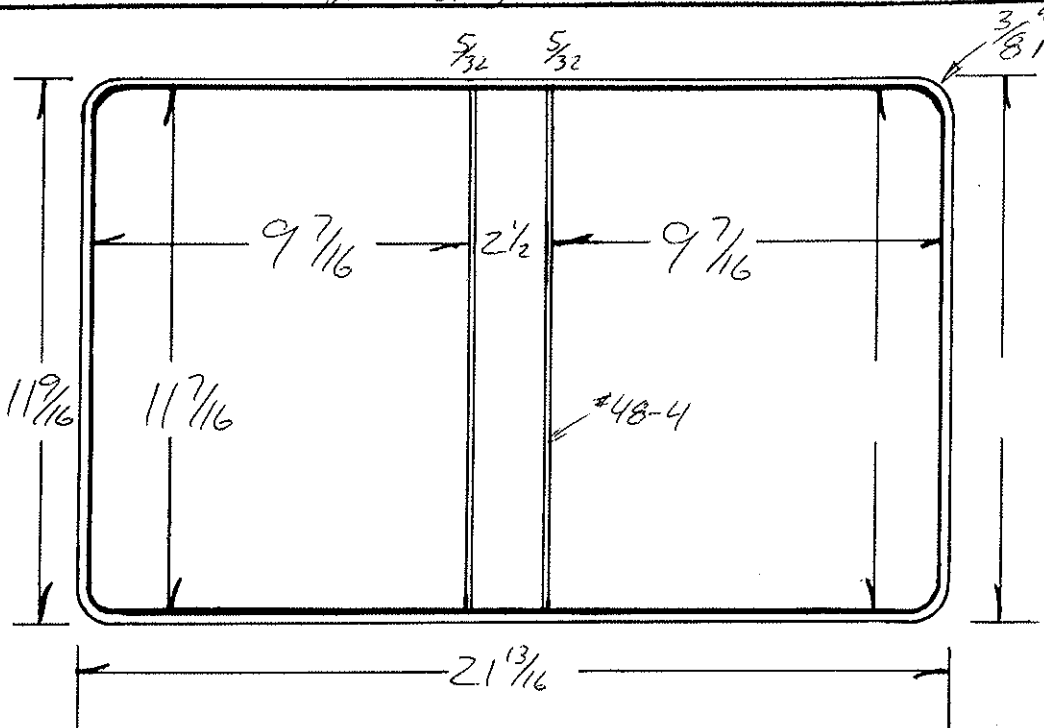

	Gauge	Thick
Tear Seal	<i>.014</i>	<i>1/16</i>
Bar Seal	<i>48-4</i>	<i>5/32</i>
Bar Seal		

	No. of Feet
Tear Seal	
Bar Seal	
Bar Seal	

Dwg. B. Pace

Check.

Code	Ga.	Pcs	Cutting Specs		Code	Ga.	Pcs	Cutting Specs	
			Size	Out				Size	Out
Cover Mat.			<i>12 1/4 X 22 5/8</i>	<i>1</i>	Lining Mat.			<i>12 1/4 X 22 5/8</i>	<i>1</i>
Cover Mat			X		Lining Mat.			X	
Vert. Pckt.			X		Horz. Pckt.			X	
Vert. Pckt.			X		Horz. Pckt.			X	
Pocket			X		Pocket			X	
Label Holder			X		Card Hlder			X	
Material			X		Material			X	
Material			X		Material			X	
Material			X		Material			X	
F.C. Board			<i>11 11/32 X 9 11/32</i>	<i>135 1</i>	B.C. Board			X	
B.G. Board			<i>11 11/32 X 9 11/32</i>	<i>135 1</i>	B.B. Board			<i>11 11/32 X 2 13/32</i>	<i>135 1</i>
Center Board			X		Board			X	
Board			X		Strip			X	
Cover Pad			X		Strip			X	
					B.B. Pad			X	

Product Code

Style Case *VRB - D* *PER SAMPLE*

Sheet Size *11 X 9* Cap. *1 1/2 D* Die No. *5071* Order No. *972443* Plate *D-8-1*

GEORGIA SAMPLE BOOK

6-20

Customer

Metal
Total Vinyl
Quantity <i>1000</i>
Date <i>5-26-92</i>
Type Corners <i>RND</i>
Radius <i>1/8" R.</i>
Completed

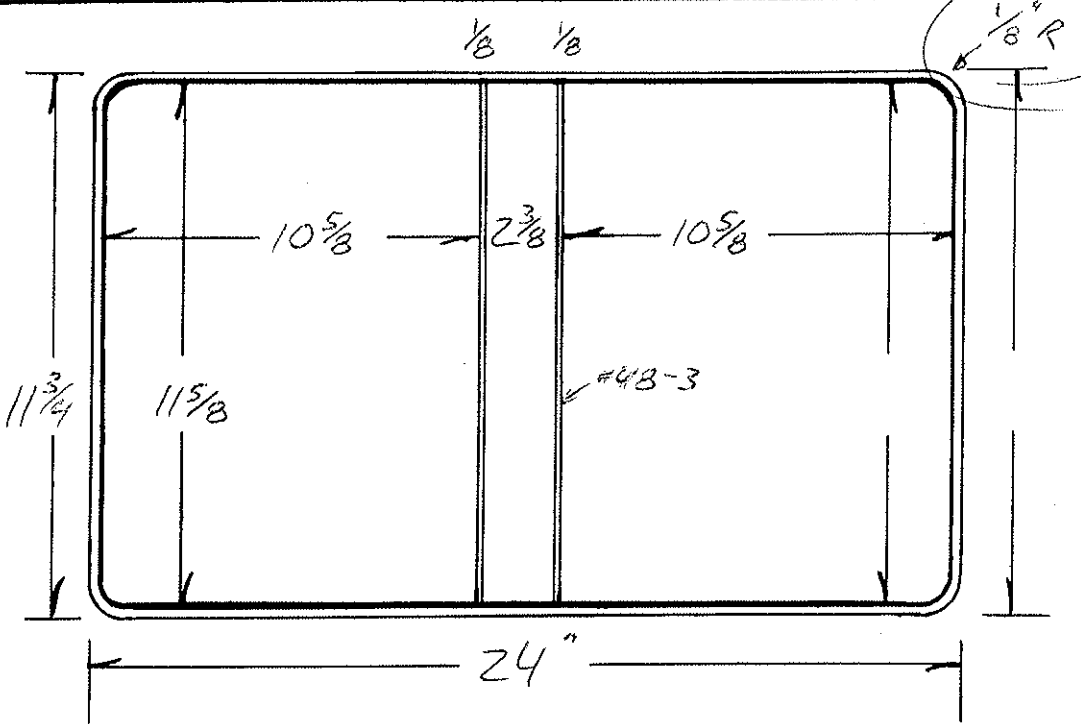

	Gauge	Thick
Tear Seal	<i>.012</i>	<i>1/16</i>
Bar Seal	<i>48-3</i>	<i>1/8</i>
Bar Seal		

	No. of Feet
Tear Seal	
Bar Seal	
Bar Seal	

Dwg - B.Pree
CHECK [Signature]

** PER SAMPLE*

REVERSE GRAIN ON ALL MATERIAL

Code	Size	Ga.	PCS	Cutting Specs		Code	Size	Ga.	Pcs.	Cutting Specs	
				Size	Out					Size	Out
Cover Mat.	<i>12 1/2 X 24 3/4</i>	<i>12</i>	<i>1</i>			Lining Mat.	<i>12 1/2 X 24 3/4</i>	<i>12</i>	<i>1</i>		
Cover Mat	X					Lining Mat.	X				
Vert. Pckt.	X					Horz. Pckt.	X				
Vert. Pckt.	X					Horz. Pckt.	X				
Pocket	X					Pocket	X				
Label Holder	X					Card holder	X				
Material <i>col.</i>	<i>11 7/8 X 13 3/4</i>	<i>8</i>	<i>1</i>			Material	X				
Material	X					Material	X				
Material	X					Material	X				
F.C. Board	<i>11 9/16 X 10 9/16</i>	<i>100</i>	<i>1</i>			B.C. Board	X				
B.C. Board	<i>11 9/16 X 10 9/16</i>	<i>100</i>	<i>1</i>			B.B. Board	<i>11 9/16 X 2 9/32</i>	<i>100</i>	<i>1</i>		
Center Board	X					Board	X				
Board	X					Strip	X				
Cover Pad	X					Strip	X				
						B.B. Pad	X				

Product Code

Style Case *VRB w/C-TRAY*

Sheet Size *11 x 9* Cap. *1"*

Die No. *5126*

Order No.

Plate

Customer

SKYBOX

Metal
Total Vinyl
Quantity
Date
Type Corners
Radius
Completed

	Gauge	Thick
Tear Seal		
Bar Seal		
Bar Seal		

	No. of Feet
Tear Seal	
Bar Seal	
Bar Seal	

DWG. B.Pace

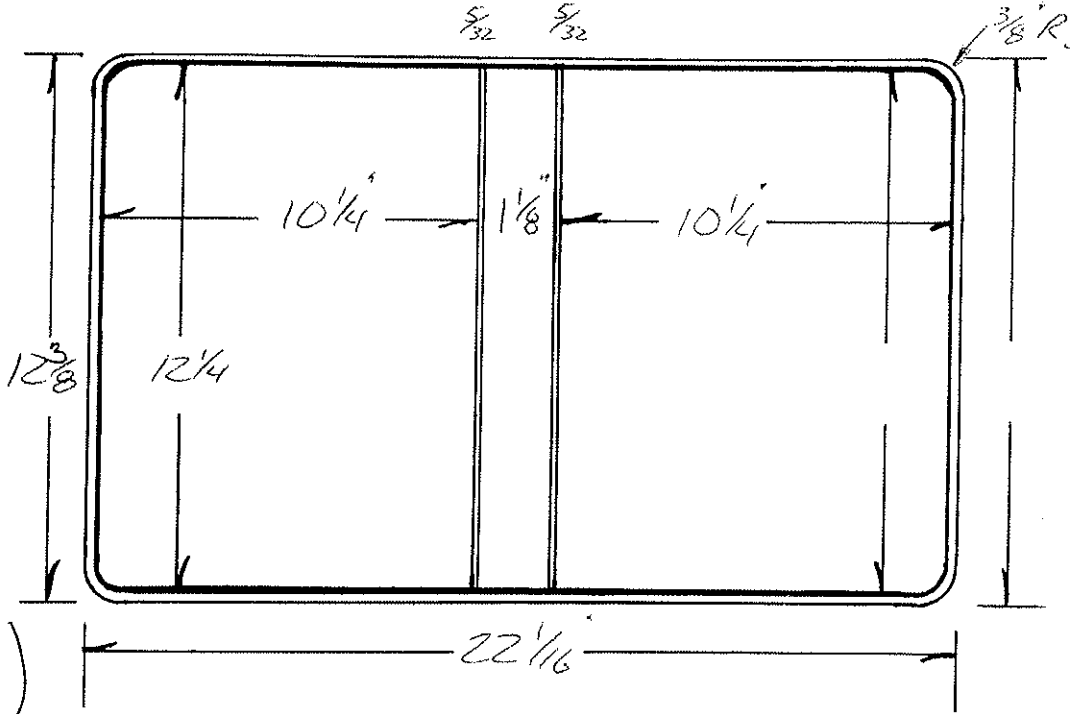

Vacuum Form Die # *5150 AB*
For C-tray

Code		Cutting Specs		Code		Cutting Specs			
		Ga.	# PCS	Size	Out	Ga.	# PCS	Size	Out
Cover Mat.	<i>13 1/8 x 22 7/8</i>		<i>1</i>			Lining Mat.	<i>13 1/8 x 12 1/16</i>		<i>1</i>
Cover Mat	X					Lining Mat.	X		
Vert. Pckt.	X					Horz. Pckt.	X		
Vert. Pckt.	X					Horz. Pckt.	X		
Pocket	X					Pocket	X		
Label Holder	<i>PICT.</i> X					Card Holder	X		
Material	<i>Clean 13 1/8 x 22 7/8</i>	<i>8</i>	<i>1</i>			Material	X		
Material	X					Material	X		
Material	X					Material	X		
F.C. Board	<i>12 5/32 x 10 5/32</i>	<i>100</i>	<i>1</i>			B.C. Board	X		
B.C. Board	<i>12 5/32 x 10 5/32</i>	<i>100</i>	<i>1</i>			B.B. Board	<i>12 5/32 x 1 1/32</i>	<i>100</i>	<i>1</i>
Center Board	X					Board	X		
Board	X					Strip	X		
Cover Pad	X					Strip	X		
						B.B. Pad	X		

Product Code

Style Case *VRB*

Sheet Size *11 X 9* Cap. *1 1/2* Die No. *5130* Order No. *972 ?* Plate

MECA CARDS

Customer
Metal
Total Vinyl
Quantity
Date
Type Corners
Radius
Completed

	Gauge	Thick
Tear Seal	<i>.017</i>	
Bar Seal		
Bar Seal		

	No. of Feet
Tear Seal	
Bar Seal	
Bar Seal	

Dwg. B Pace

1 UP OF FIAB# 4977

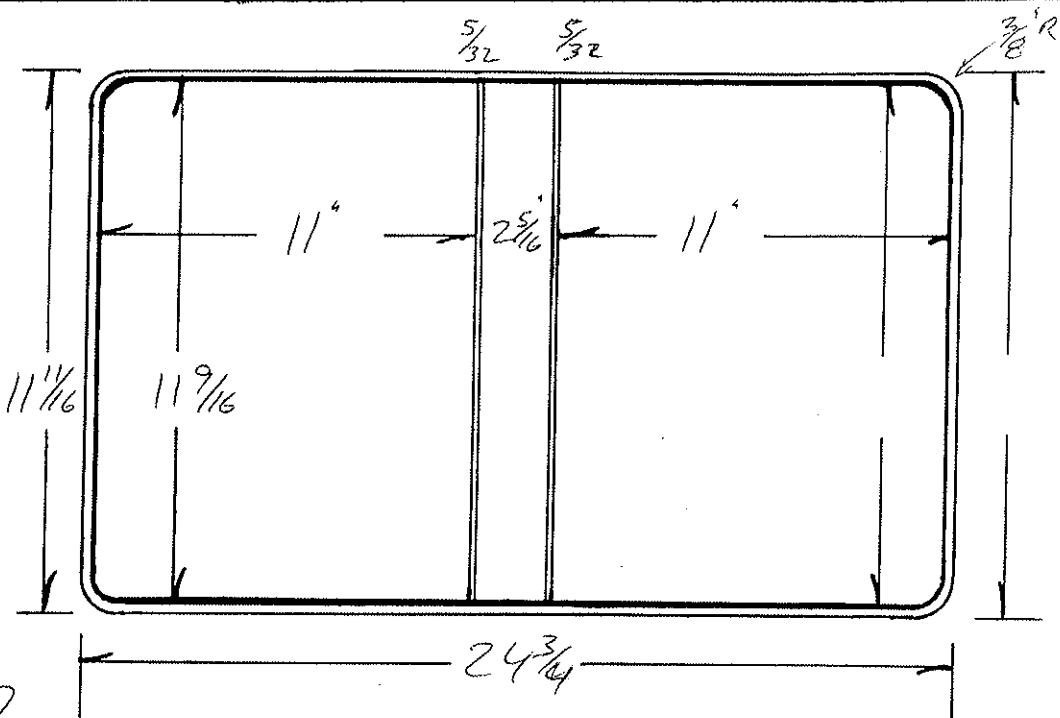

Code		Ga. #		PCS		Cutting Specs		Code		Ga. #		PCS		Cutting Specs	
						Size	Out					Size	Out		
Cover Mat.				<i>11</i>	<i>1</i>	<i>12 1/2 X 25 1/2</i>		Lining Mat.				<i>11</i>	<i>1</i>	<i>12 1/2 X 25 1/2</i>	
Cover Mat.						<i>X</i>		Lining Mat.						<i>X</i>	
Vert. Pckt.						<i>X</i>		Horz. Pckt.						<i>X</i>	
Vert. Pckt.						<i>X</i>		Horz. Pckt.						<i>X</i>	
Pocket						<i>X</i>		Pocket						<i>X</i>	
Label Holder				<i>8</i>	<i>1</i>	<i>2 5/8 X 3 1/8</i>		Card Holder						<i>X</i>	
Material	<i>PICT.</i>					<i>12 1/2 X 25 1/2</i>		Material						<i>X</i>	
Material						<i>X</i>		Material						<i>X</i>	
Material						<i>X</i>		Material						<i>X</i>	
F.C. Board				<i>120</i>	<i>1</i>	<i>11 15/32 X 10 29/32</i>		B.C. Board						<i>X</i>	
B.C. Board				<i>120</i>	<i>1</i>	<i>11 15/32 X 10 29/32</i>		B.B. Board				<i>120</i>	<i>1</i>	<i>11 15/32 X 2 7/32</i>	
Center Board						<i>X</i>		Board						<i>X</i>	
Board						<i>X</i>		Strip						<i>X</i>	
Cover Pad						<i>X</i>		Strip						<i>X</i>	
								B.B. Pad						<i>X</i>	

2. Up Die 5054
Product Code

Style Case VRB

Sheet Size 11 x 9 Cap. 1 1/2 Die No. 5132 Order No. 972915 Plate D-10-2

PLYMOUTH INC.

8-7

Customer

Metal
Total Vinyl
Quantity 3,000
Date 7-27-92
Type Corners
Radius 3/8
Completed

	Gauge	Thick
Tear Seal	.008	1/16
Bar Seal		
Bar Seal		

	No. of Feet
Tear Seal	
Bar Seal	
Bar Seal	

DWG. B. Pace

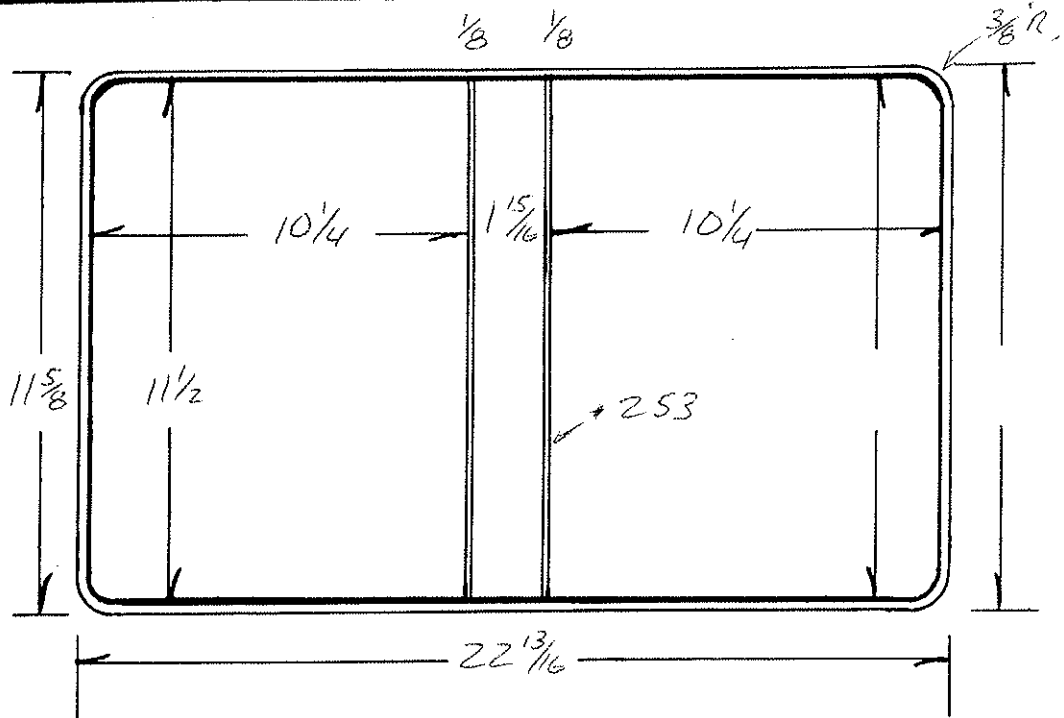

		Cutting Specs						Cutting Specs			
Code		Ga.	# PCS	Size	Out	Code		Ga.	# Pcs.	Size	Out
Cover Mat.	12 1/4 x 23 5/8	7	1			Lining Mat.	12 1/4 x 23 5/8	10	1		
Cover Mat.	X					Lining Mat.	X				
Vert. Pckt.	X					Horz. Pckt.	X				
Vert. Pckt.	X					Horz. Pckt.	X				
Pocket	X					Pocket	X				
Label Holder	X					Card Holder	X				
Material	X					Material	X				
Material	X					Material	X				
Material	X					Material	X				
F.C. Board	11 7/16 x 10 3/16	100	1			B.C. Board	X				
B.C. Board	11 7/16 x 10 3/16	100	1			B.B. Board	11 7/16 x 12 1/32	100	1		
Center Board	X					Board	X				
Board	X					Strip	X				
Cover Pad	X					Strip	X				
						B.B. Pad	X				

Fiab Die # 5312
 Product Code

Style Case VRB

Overall Sheet Size 12 1/4 X 11 1/4 Cap. 1 1/2 Die No. 5162

Order No. 973386.1 Plate D11-3

Customer

Colad

9-11

Metal
Total Vinyl
Quantity <u>24</u>
Date <u>9-9-92</u>
Type Corners <u>Rad</u>
Radius <u>3/8</u>
Completed

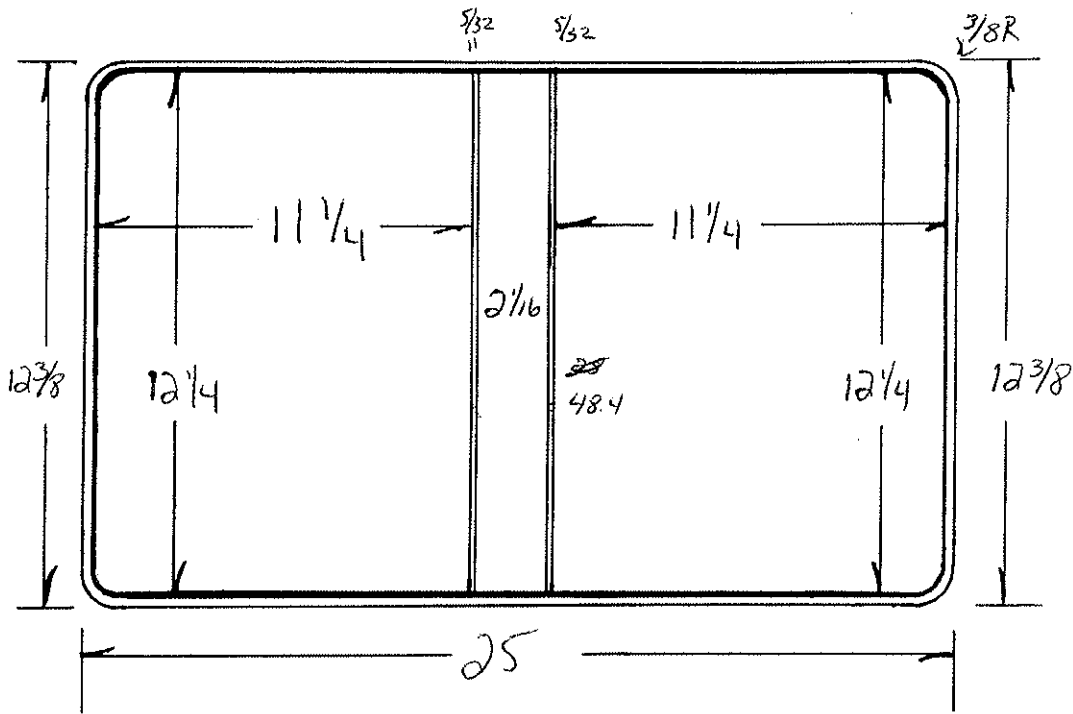

	Gauge	Thick
Tear Seal	<u>.008</u>	<u>1/16</u>
Bar Seal	<u>484</u>	<u>5/32</u>
Bar Seal		

	No. of Feet
Tear Seal	
Bar Seal	
Bar Seal	

Dwg Tim

Code	Ga.	#	Cutting Specs		Code	Ga.	#	Cutting Specs			
			Size	Out				Size	Out		
Cover Mat. <u>Clear</u>	<u>13 1/8</u>	<u>X</u>	<u>25 3/4</u>	<u>8</u>	<u>1</u>	Lining Mat. <u>Blue</u>	<u>13 1/8</u>	<u>X</u>	<u>25 3/4</u>	<u>8</u>	<u>1</u>
Cover Mat.		X				Lining Mat.		X			
Vert. Pckt.		X				Horz. Pckt.		X			
Vert. Pckt.		X				Horz. Pckt.		X			
Pocket		X				Pocket		X			
Label Holder		X				Card Holder		X			
Material		X				Material		X			
Material		X				Material		X			
Material		X				Material		X			
F.C. Board <u>Mexite</u>	<u>12 5/32</u>	<u>X</u>	<u>11 5/32</u>		<u>1</u>	B.C. Board		X			
B.C. Board <u>Mexite</u>	<u>12 5/32</u>	<u>X</u>	<u>11 5/32</u>		<u>1</u>	B.B. Board		X			
Center Board <u>Pchip</u>	<u>12 3/32</u>	<u>X</u>	<u>1 3/32</u>	<u>100</u>		Board		X			
Board		X				Strip		X			
Cover Pad		X				Strip		X			
						B.B. Pad		X			
Pictorial sizes											
F.C.			<u>12 3/16 X 11 3/16</u>								
B.C.			<u>12 3/16 X 11 3/16</u>								
B.B.			<u>12 3/16 X 2</u>								
			<u>(Sizes Per BNF)</u>								

2-Up Die # 4751
Product Code

Style Case URB Main Binder

Sheet Size $11\frac{1}{2} \times 9\frac{1}{2}$ Cap. 1" Die No. 5768

Order No. 973401 3404.1 3405.1 Plate D11-8

Customer Colad

9-22

Metal
Total Vinyl
Quantity
Date <u>9-17-92</u>
Type Corners <u>Rd</u>
Radius <u>R 1/8</u>
Completed

	Gauge	Thick
Tear Seal	<u>.014</u>	<u>1/16</u>
Bar Seal		
Bar Seal		

	No. of Feet
Tear Seal	
Bar Seal	
Bar Seal	

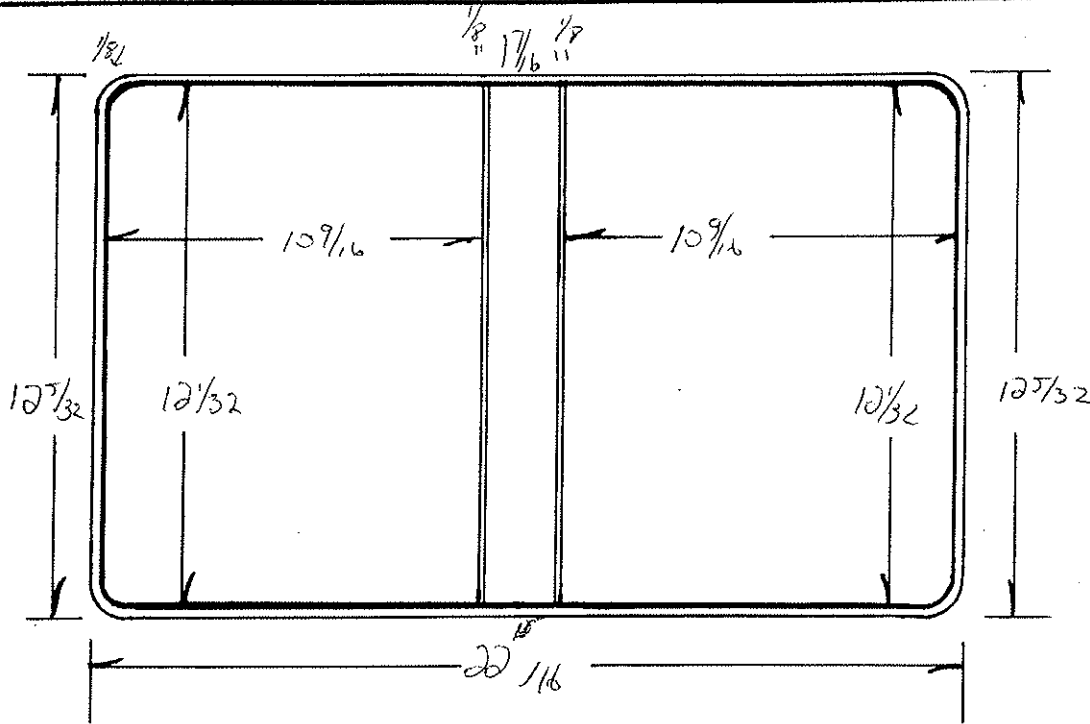

Code	Ga.	Pcs	Cutting Specs		Code	Ga.	Pcs	Cutting Specs	
			Size	Out				Size	Out
Cover Mat.			$12\frac{7}{8} \times 23\frac{1}{16}$	1	Lining Mat.			$12\frac{7}{8} \times 23\frac{1}{16}$	1
Cover Mat			X		Lining Mat.			X	
Vert. Pckt.			X		Horz. Pckt.			$1\frac{1}{2} \times 23\frac{1}{16}$	1
Vert. Pckt.			X		Horz. Pckt.			$5\frac{3}{8} \times 23\frac{1}{16}$	
Pocket			X		Pocket	<u>COL</u>		$12\frac{9}{32} \times 23\frac{1}{16}$	1
Label Holder			X		Card Holder			X	
Material			X		Material			X	
Material			X		Material			X	
Material			X		Material			X	
F.C. Board			$11\frac{3}{32} \times 10\frac{1}{2}$	100	1	B.C. Board		X	
B.G. Board			$11\frac{3}{32} \times 10\frac{1}{2}$	100	1	B.B. Board		X	
Center Board			$11\frac{3}{32} \times 1\frac{1}{32}$	100	1	Board		X	
Board			X		Strip			X	
Cover Pad			X		Strip			X	
					B.B. Pad			X	

Product Code

Style Case

VRB

Sheet Size 11 x 9 1/4 Cap. 1

Die No. 5170 A+B Order No. 973393.1

Plate D12.1

Customer

Southern Company Services

10-8

Material
Total Vinyl
Quantity 500
Date 9-17-92
Type Corners Rd
Radius 3/8
Completed

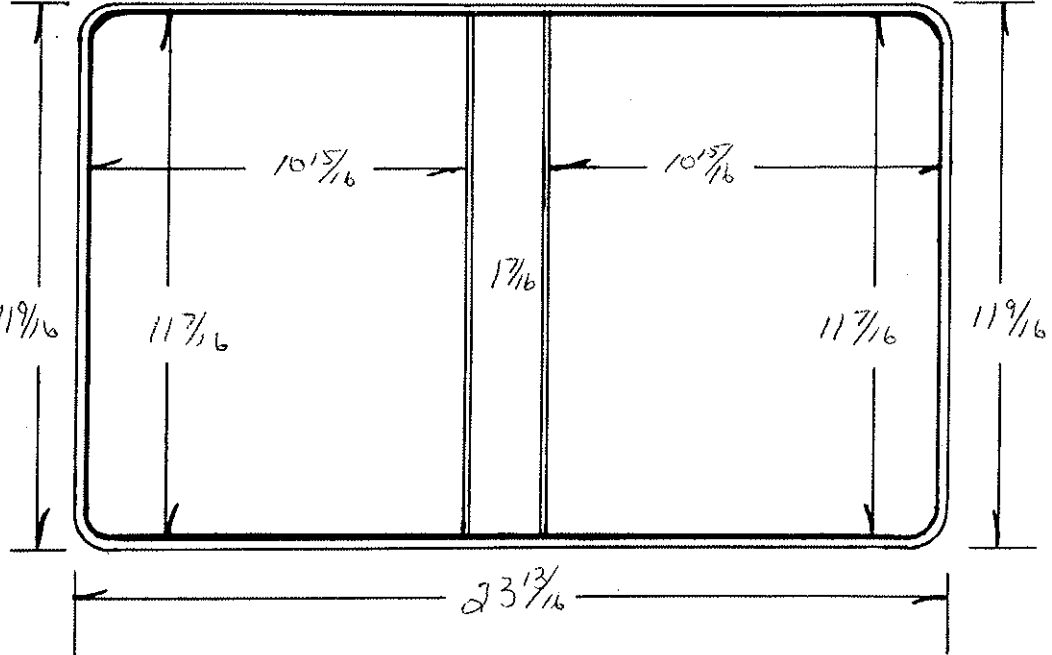

	Gauge	Thick
Tear Seal	.014	1/16
Bar Seal	.178	5/16
Bar Seal		

	No. of Feet
Tear Seal	
Bar Seal	
Bar Seal	

Tim

Code	Ga.	PCS	Cutting Specs		Code	Ga.	Pcs.	Cutting Specs	
			Size	Out				Size	Out
Cover Mat.		1	12 3/16 X 24 7/16		Lining Mat.		1	12 3/16 X 24 7/16	
Cover Mat. Padded		1	12 9/16 X 24 3/16		Lining Mat.		1	12 9/16 X 24 13/16	
Vert. Pckt.			X		Horz. Pckt.			X	
Vert. Pckt.			X		Horz. Pckt.			X	
Pocket			X		Pocket			X	
Label Holder			X		Card Hlder			X	
Material			X		Material			X	
Material			X		Material			X	
Material			X		Material			X	
F.C. Board		100	1	11 3/8 X 10 7/8	B.C. Board			X	
B.C. Board		100	1	1 3/8 X 10 7/8	B.B. Board			X	
Center Board		100	1	11 3/8 X 1 1/32	Board			X	
Board				X	Strip			X	
Cover Pad				X	Strip			X	
FC 9 BB Die Cut				12 3/8 X 13 7/8	B.B. Pad			X	

Product Code

Style Case VRB Round Ring

Sheet Size 11 x 9 1/4 1/2 Cap. 3"

Die No. 5235

Order No. 974/05.1

Plate D14-B

Refraction Technology

Customer

Metal
Total Vinyl
Quantity <u>300</u>
Date <u>12-14-92</u>
Type Corners <u>RND</u>
Radius <u>3/8</u>
Completed

	Gauge	Thick
Tear Seal	<u>.014</u>	<u>2/32</u>
Bar Seal	<u>484</u>	<u>5/32</u>
Bar Seal		

	No. of Feet
Tear Seal	
Bar Seal	
Bar Seal	

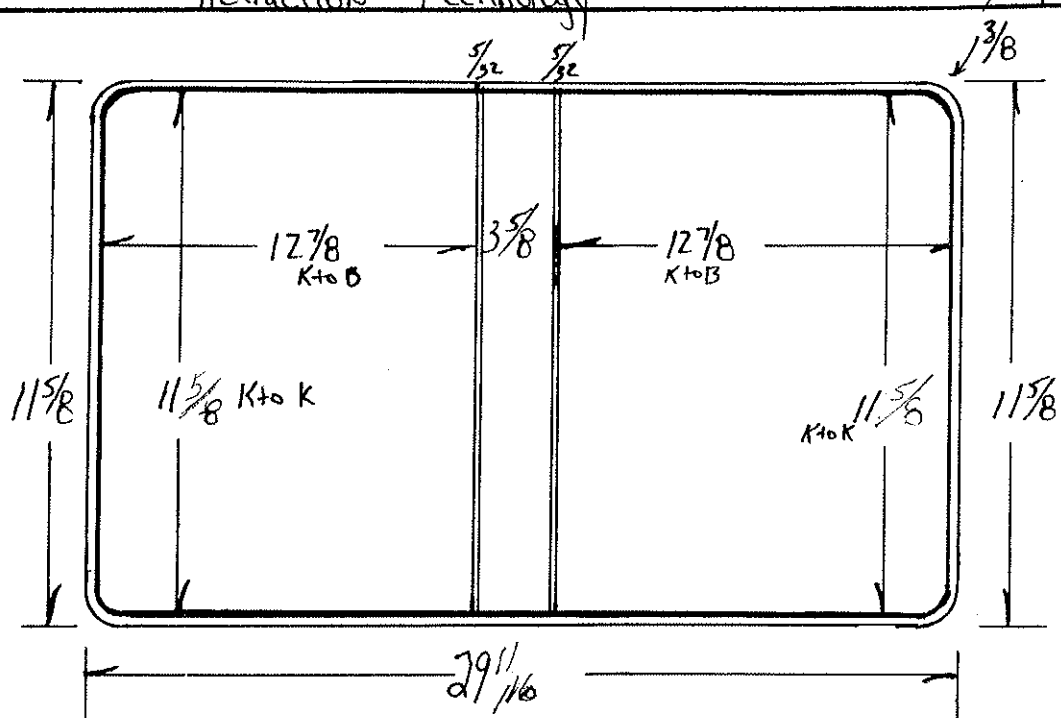

Code	Ga.	#	PCS	Cutting Specs		Code	Ga.	#	Pcs.	Cutting Specs	
				Size	Out					Size	Out
Cover Mat.						Lining Mat.					
Col Cover Mat						Lining Mat.					
Vert. Pckt.						Horz. Pckt.					
Vert. Pckt.						Horz. Pckt.					
Pocket						Pocket					
Label Holder						Card Holder					
Material						Material					
Material						Material					
Material						Material					
F.C. Board						B.C. Board					
B.C. Board						B.B. Board					
Center Board						FC Board					
Board						Strip					
Cover Pad						Strip					
						B.B. Pad					

Oversize: Holds 2-445 Trays

DIE #	5265	STYLE CASE	VRB	LOCATION	
SHEET SIZE	11 x 8 1/2 + 1/2	CAP.	2"	ORDER NO.	
CUSTOMER	IBM - EBSCO MEDIA			DUE DATE	

QUANTITY	
DATE	1-22-93

RADIUS	3/8
COMPLETED	

TEAR SEAL	.014
BAR SEAL	484

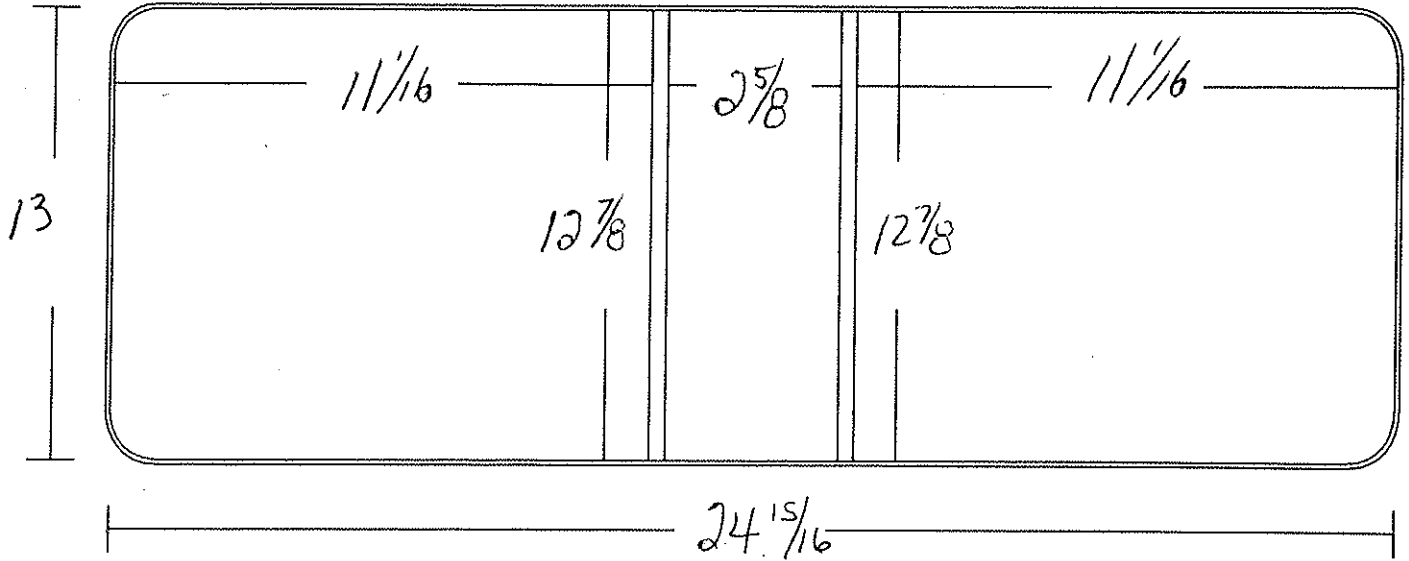

MATERIAL

	CODE		GA	PCS		CODE		GA	PCS
COVER MATL		13 3/4 X 25 3/4		1	LINING		13 3/4 X 25 3/4		1
COVER MATL		X			LINING		X		
VERT PKT		X			HORZ PKT		X		
VERT PKT		X			HORZ PKT		X		
CARD HOLDER		X			DIAGONAL PKT		X		
COL		13 1/8 X 25 3/4			LABEL HOLDER		X		
EX. COL		X			GUSSETT		X		
		X			REINF.		X		
		X					X		

PRINTS

FRONT COVER	X	BACK BONE	X	BACK COVER	X
-------------	---	-----------	---	------------	---

BOARDS

	CODE		PT	PCS		CODE		PT	PCS
F.C. BOARD		12 25/32 X 10 3/32	120	1	F.C. BOARD		X		
B.B. BOARD		12 25/32 X 2 17/32	120	1	B.B. BOARD		X		
B.C. BOARD		12 25/32 X 10 3/32	120	1	B.C. BOARD		X		
B. UP STRIP		X					X		
		X					X		

2-up Die #5401

Matched Sample

DIE # 5310	STYLE CASE VRB	LOCATION D18-4
SHEET SIZE 11 x 8 1/2 + 1/2	CAP. 1/2	ORDER NO. 974854
CUSTOMER VB & C Sales		DUE DATE

QUANTITY	1
DATE	4-7-93

RADIUS	3/8
COMPLETED	

TEAR SEAL	.014
BAR SEAL	483

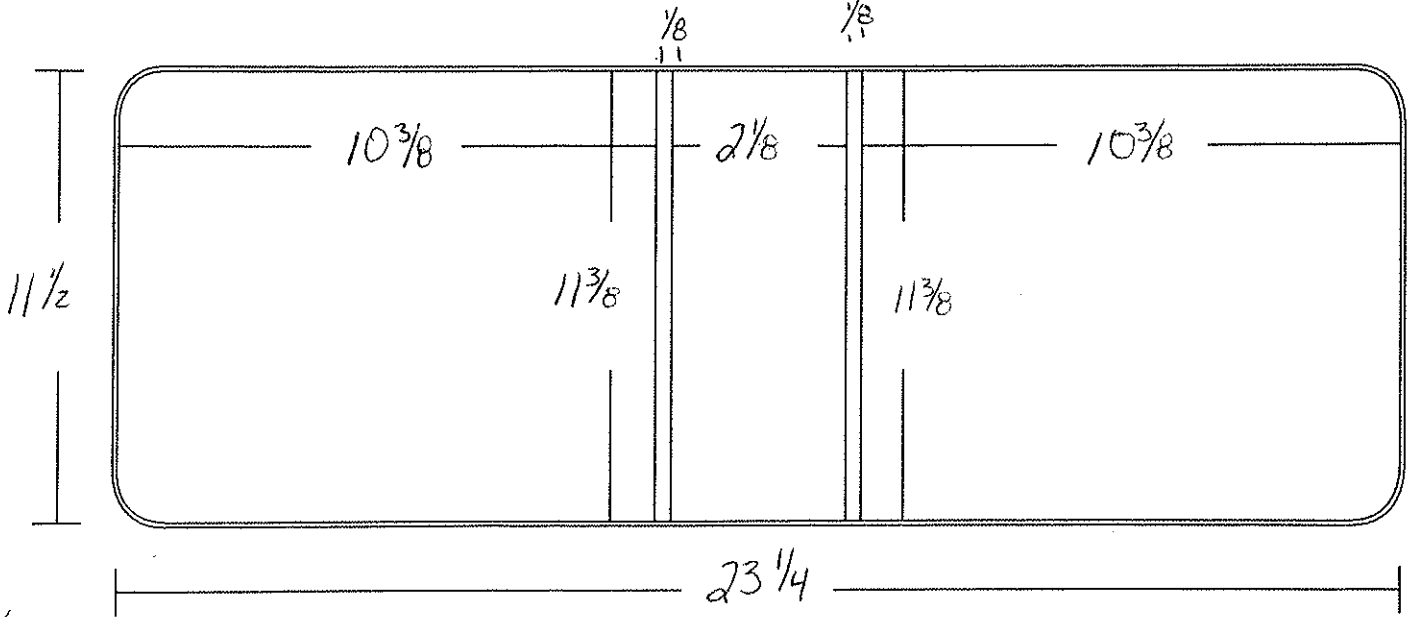

Jim

MATERIAL

	CODE		GA	PCS		CODE		GA	PCS
COVER MATL		12 1/4 X 24			LINING		12 1/4 X 24		
COVER MATL		X			LINING		X		
VERT PKT		X			HORZ PKT		X		
VERT PKT		X			HORZ PKT		X		
CARD HOLDER		X			DIAGONAL PKT		X		
COL		X			LABEL HOLDER		X		
EX. COL		X			GUSSETT		X		
		X			REINF.		X		
		X					X		

PRINTS

FRONT COVER	X	BACK BONE	X	BACK COVER	X
-------------	---	-----------	---	------------	---

BOARDS

	CODE		PT	PCS		CODE		PT	PCS
F.C. BOARD		11 5/16 X 10 5/16	100	1	F.C. BOARD		11 9/32 X 10 9/32	120	1
B.B. BOARD		11 5/16 X 2 1/32	100	1	B.B. BOARD		11 9/32 X 2 1/32	120	1
B.C. BOARD		11 5/16 X 10 5/16	100	1	B.C. BOARD		11 9/32 X 10 9/32	120	1
B. UP STRIP		11 5/16 X 2	22	1			X		
		X					X		

Angle D - Stock Metal - old style

DIE # 5325	STYLE CASE VRB D-Ring	LOCATION D19-8
SHEET SIZE 11 X 9 + 1/2	CAP. 1"	ORDER NO. 975102
CUSTOMER Graphic Directions		DUE DATE

QUANTITY	50
DATE	5-11-93

RADIUS	3/8
COMPLETED	

TEAR SEAL	.014
BAR SEAL	483

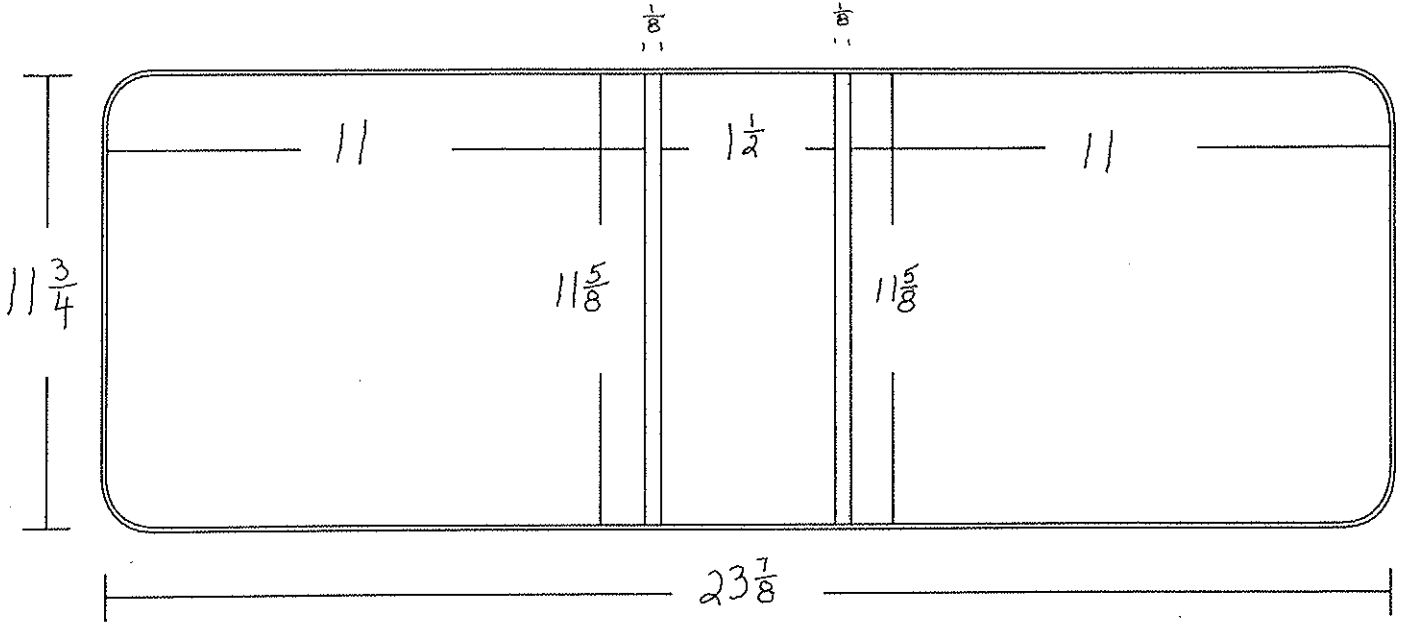

MATERIAL

	CODE		GA	PCS		CODE		GA	PCS
COVER MATL		12 1/2 X 24 5/8		1	LINING		12 1/2 X 24 5/8		1
COVER MATL		X			LINING		X		
VERT PKT		X			HORZ PKT		5 3/8 X 24 5/8		1
VERT PKT		X			HORZ PKT		X		
CARD HOLDER		X			DIAGONAL PKT		X		
COL		11 7/8 X 24 5/8			LABEL HOLDER		X		
EX. COL		11 7/8 X 14			GUSSETT		X		
		X			REINF.		X		
		X					X		

PRINTS

FRONT COVER	X	BACK BONE	X	BACK COVER	X
-------------	---	-----------	---	------------	---

BOARDS

	CODE		PT	PCS		CODE		PT	PCS
F.C. BOARD		11 9/16 X 10 15/16	100	1	F.C. BOARD		11 17/32 X 10 29/32	120	1
B.B. BOARD		11 9/16 X 1 13/32	100	1	B.B. BOARD		11 17/32 X 1 13/32	120	1
B.C. BOARD		11 9/16 X 10 15/16	100	1	B.C. BOARD		11 17/32 X 10 29/32	120	1
B. UP STRIP		X					X		
		X					X		

DIE # 5403		STYLE CASE VRB <i>LBHR Tenacity</i>		LOCATION <i>ES-6</i>	
SHEET SIZE 11 7/8 +1/2		CAP. 3		ORDER # 65805	
CUSTOMER NSC INTERNATIONAL				DUE DATE	
QUANTITY	300	RADIUS	3/8	TEAR SEAL	.012
DATE	8-18-93	COMPLETED		BAR SEAL	254

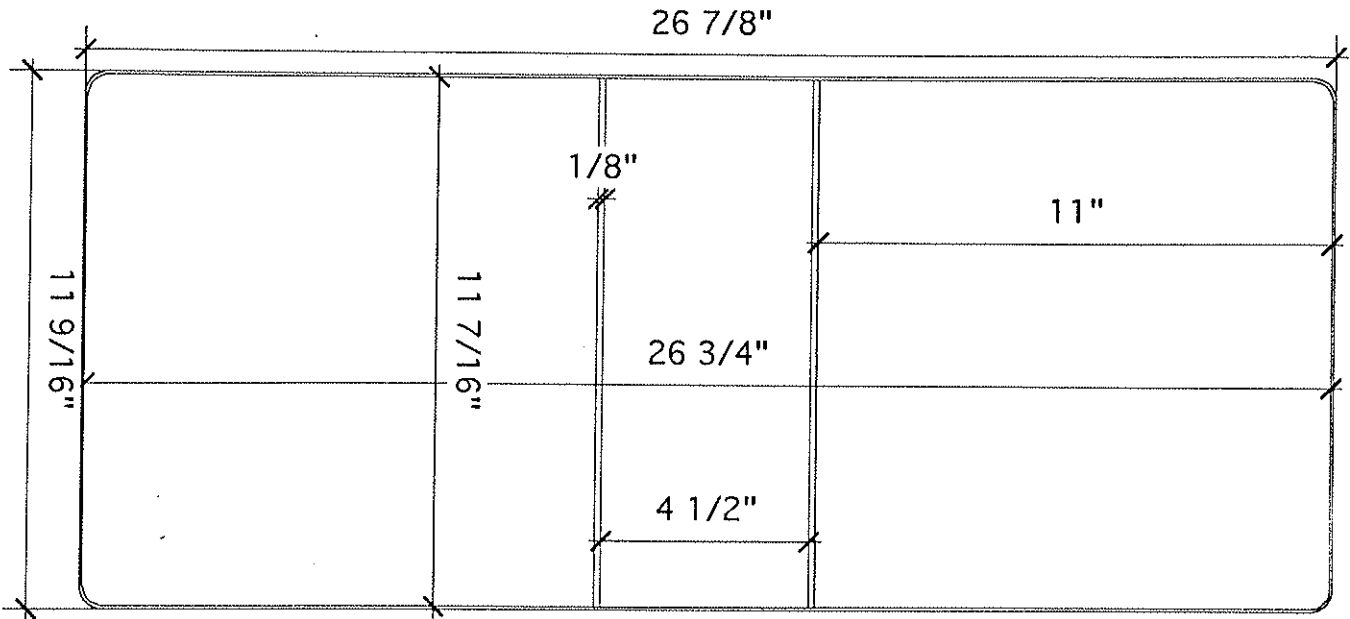

MATERIAL SPECS

GA PCS

GA PCS

COVER MATL	12 5/16 X 27 5/8		LINING	12 5/16 X 27 5/8	
COVER MATL			LINING		
VERT PKT			HORZ PKT	5 3/8 X 27 5/8	
VERT PKT			HORZPKT		
CARD HOLDER			DIAGONAL PKT		
COL			LABEL HOLDER		
EX COL			GUSSETT		
			REINF		

BOARD SPECS

F.C. BOARD	11 11/32 X 10 29/32	130	F.C. BOARD		
B.B. BOARD			B.B. BOARD		
B.C. BOARD	11 11/32 X 10 29/32	130	B.C. BOARD		
BU STRIP					

NOC

(coll style)

DIE # 5405		STYLE CASE VRB STRAIGHT D		LOCATION E5-8	
SHEET SIZE 11 X 9 + 1/2.		CAP. 2 1/2		ORDER # 975189	
CUSTOMER PRODUCTION MACH.				DUE DATE	
QUANTITY	500	RADIUS	3/8	TEAR SEAL	.012
DATE	8-23-93	COMPLETED		BAR SEAL	484

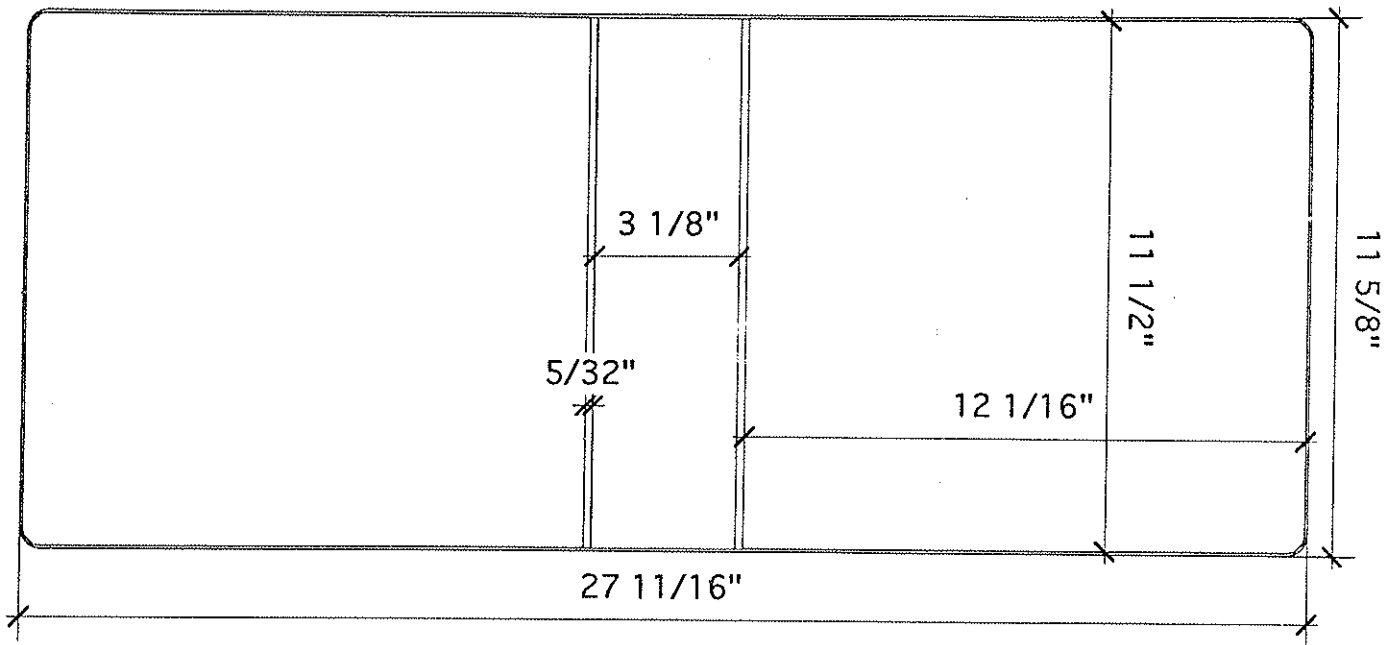

MATERIAL SPECS

GA PCS

GA F

COVER MATL	12 3/8 X 28 7/16		1	LINING	12 3/8 X 28 7/16		1
COVER MATL				LINING			
VERT PKT				HORZ PKT			
VERT PKT				HORZPKT			
CARD HOLDER				DIAGONAL PKT			
COL				LABEL HOLDER			
EX COL				GUSSETT			
				REINF			

BOARD SPECS

F.C. BOARD	11 13/32 X 11 31/32	120	1	F.C. BOARD			
B.B. BOARD	11 13/32 X 3 1/32	120	1	B.B. BOARD			
B.C. BOARD	11 13/32 X 11 31/32	120	1	B.C. BOARD			
BU STRIP							

Oversized to hold - 2 VHS trays (Note)

DIE # 5478		STYLE CASE VINYL RING BINDER		LOCATION	
SHEET SIZE 11 X 9		CAP. 2		ORDER # 976813	
CUSTOMER UPS			DUE DATE		
QUANTITY	1000	RADIUS	3/8	TEAR SEAL	.012
DATE	7-12-93	COMPLETED		BAR SEAL	484

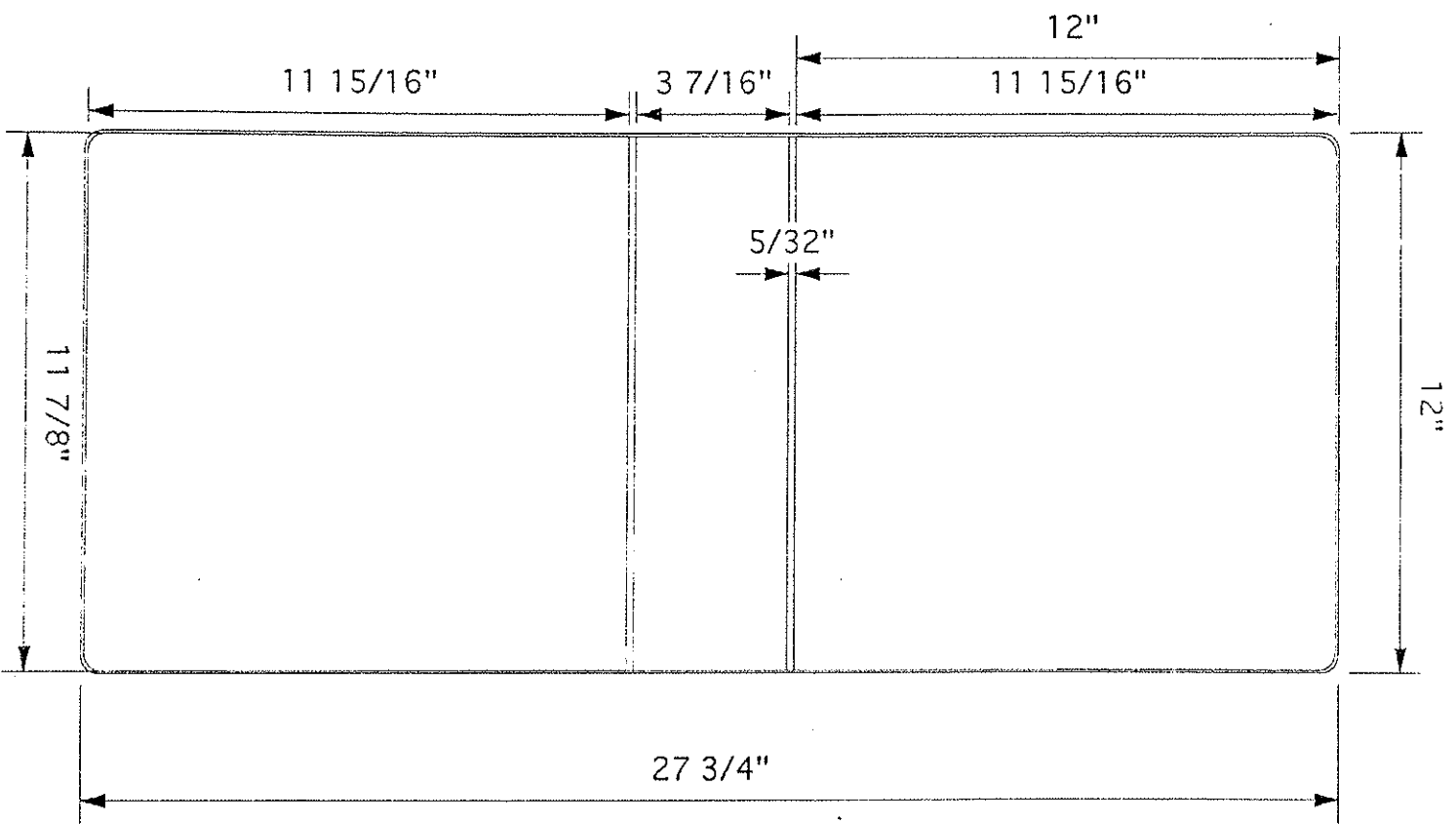

MATERIAL SPECS		GA	PCS	GA		PCS
COVER MATL	12 3/4 X 28 1/2		1	LINING	12 3/4 X 28 1/2	1
COVER MATL				LINING		
VERT PKT				HORZ PKT	5 3/8 X 12 1/2	1
VERT PKT				HORZPKT		
CARD HOLDER				DIAGONAL PKT		
COL				LABEL HOLDER		
EX COL				GUSSETT		
				REINF		

BOARD SPECS					
F.C. BOARD	11 25/32 X 11 27/32	120	1	F.C. BOARD	
B.B. BOARD	11 25/32 X 3 11/32	120	1	B.B. BOARD	
B.C. BOARD	11 25/32 X 11 27/32	120	1	B.C. BOARD	
BU STRIP	11 25/32 X 3 11/32	22	1		

DIE # 5495		STYLE CASE VINLY K-LINE METAL		LOCATION	
SHEET SIZE 11 X 8 1/2 + 1/2		CAP. 3		ORDER # 977030	
CUSTOMER STANDARD OF LYNN				DUE DATE	
QUANTITY	500	RADIUS	3/8	TEAR SEAL	.012
DATE	1-6-93	COMPLETED		BAR SEAL	484

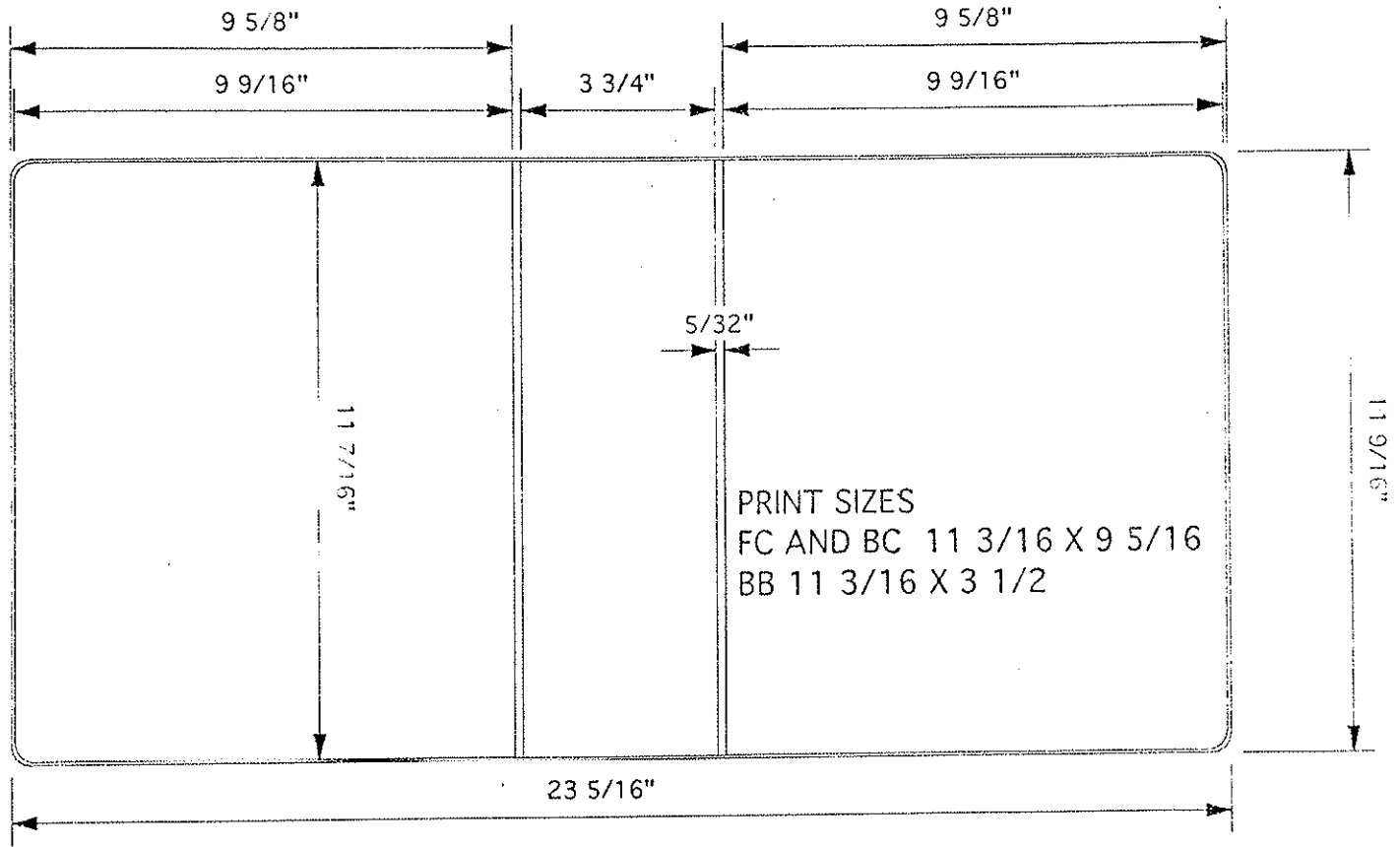

MATERIAL SPECS			GA		PCS	
COVER MATL	12 5/16 X 24 1/16	1	LINING	12 5/16 X 24 1/16	1	
COVER MATL			LINING			
VERT PKT			HORZ PKT			
VERT PKT			HORZPKT	5 3/8 X 24 1/16	1	
CARD HOLDER			DIAGONAL PKT			
COL	11 11/16 X 24 1/16	1	LABEL HOLDER			
EX COL			GUSSETT			
			REINF			

BOARD SPECS						
F.C. BOARD	11 11/32 X 9 15/32	120	1	F.C. BOARD		
B.B. BOARD	11 11/32 X 3 21/32	120	1	B.B. BOARD		
B.C. BOARD	11 11/32 X 9 15/32	120	1	B.C. BOARD		
BU STRIP						

DIE # 5558		STYLE CASE VINYL RING BINDER W HOLE		LOCATION E 8-7	
SHEET SIZE 11 X 9		CAP. 1		ORDER # 977902	
CUSTOMER PAPER DIRECT INC.			DUE DATE		
QUANTITY		RADIUS	3/8	TEAR SEAL	.012
DATE		COMPLETED		BAR SEAL	484

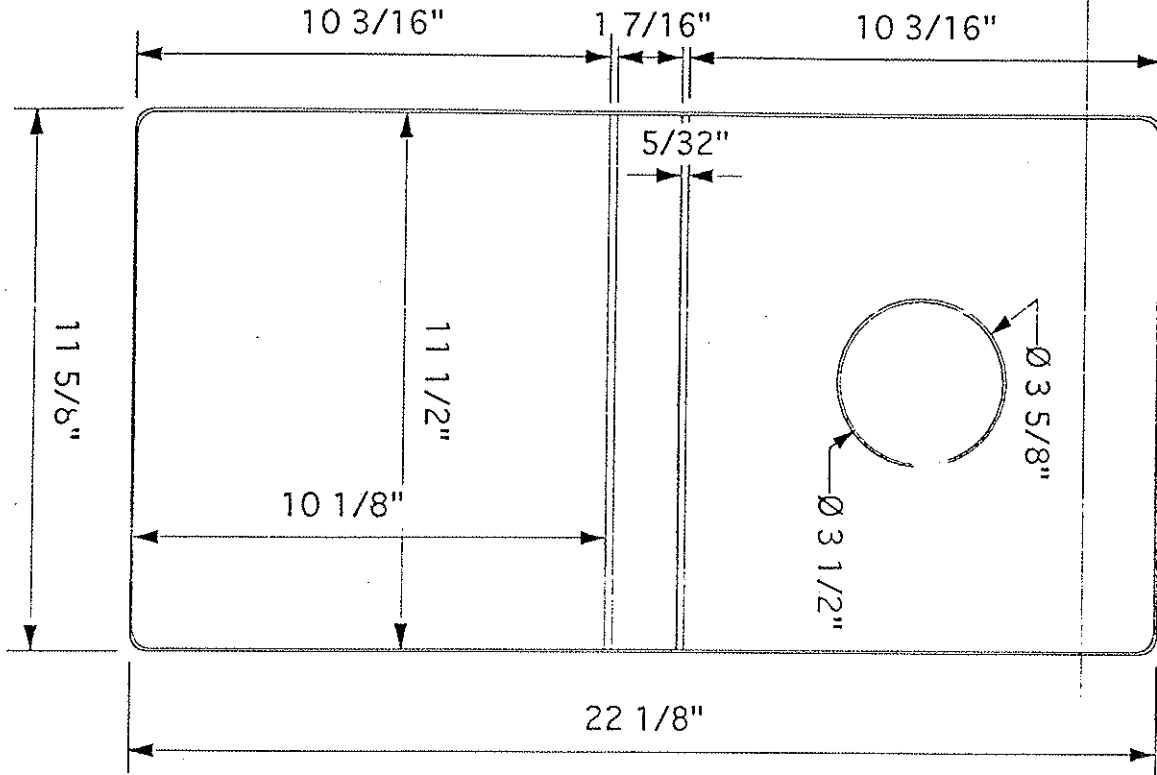

MATERIAL SPECS

GA PCS

GA PCS

COVER MATL	12 3/8 x 22 7/8	1	LINING	12 3/8 x 22 7/8	1
COVER MATL			LINING		
VERT PKT			HORZ PKT		
VERT PKT			HORZPKT		
CARD HOLDER			DIAGONAL PKT		
COL			LABEL HOLDER		
EX COL			GUSSETT		
			REINF		

BOARD SPECS

DIE CUT F.C.	12 13/32 x 11 1/32	120	1	F.C. BOARD	
B.B. BOARD	11 13/32 x 1 11/32	120	1	B.B. BOARD	
B.C. BOARD	11 13/32 x 10 1/32	120	1	B.C. BOARD	
BU STRIP					

DIE # 5575		STYLE CASE VINYL D RING		LOCATION E 10 -2	
SHEET SIZE 11 X 9 1/4		CAP. 2		ORDER # 977968.2	
CUSTOMER LCI COMMUNICATIONS				DUE DATE	
QUANTITY	2000	RADIUS	3/8	TEAR SEAL	.012
DATE		COMPLETED		BAR SEAL	484

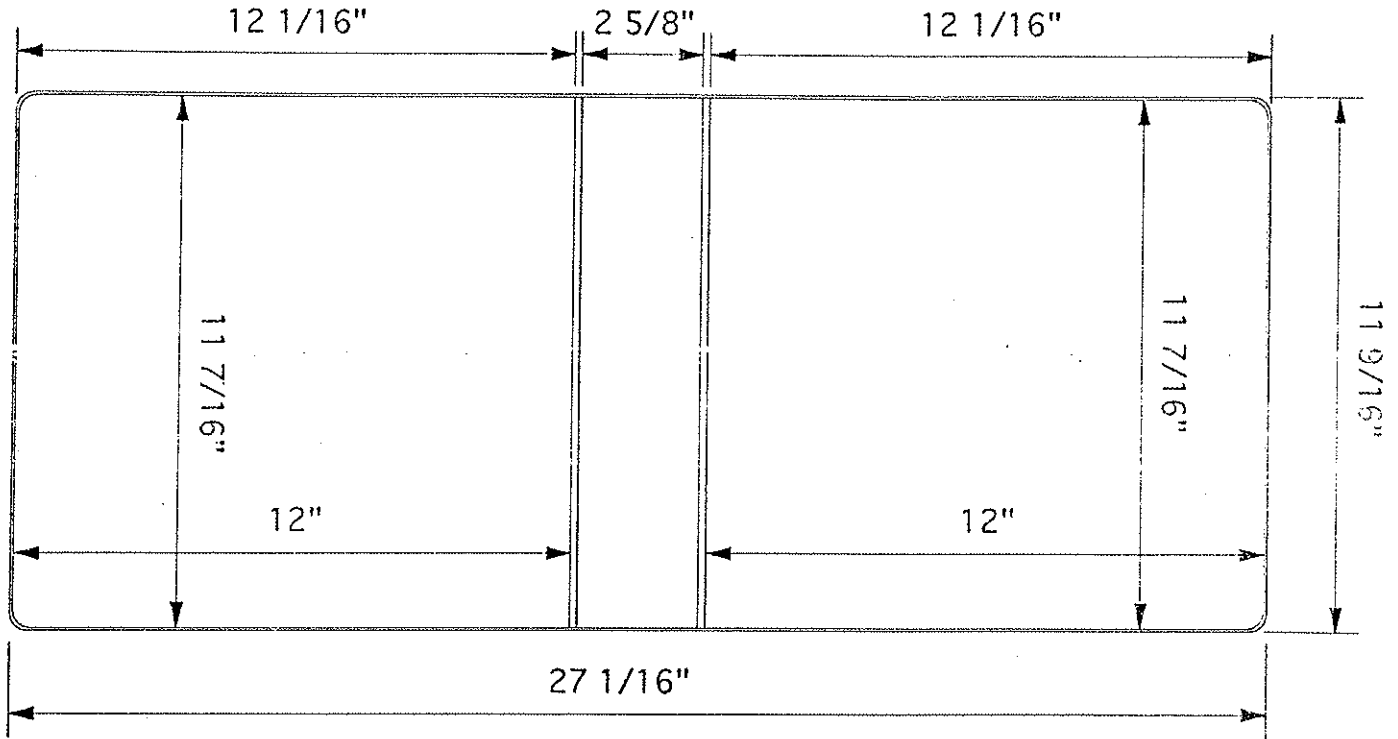

MATERIAL SPECS		GA		PCS		GA		PCS	
COVER MATL	12 5/16 x 27 13/16	1		LINING	12 5/16 x 27 13/16	1			
COVER MATL				LINING					
VERT PKT				HORZ PKT	5 3/8 x 12 9/16	1			
VERT PKT				HORZPKT					
CARD HOLDER				DIAGONAL PKT					
COL				LABEL HOLDER					
EX COL				GUSSETT					
				REINF					

BOARD SPECS									
F.C. BOARD	11 11/32 x 11 29/32	120	1	F.C. BOARD					
B.B. BOARD	11 11/32 x 2 17/32	120	1	B.B. BOARD					
B.C. BOARD	11 11/32 x 11 29/32	120	1	B.C. BOARD					
BU STRIP	11 5/16 x 11 7/8	48	1						

DIE # 5621		STYLE CASE VRB WITH CLEAR FRONT		LOCATION E 12-6	
SHEET SIZE 11 X 9		CAP. 1/2		ORDER # 978878	
CUSTOMER FRANKENMUTH MUTUAL INSURANCE				DUE DATE	
QUANTITY		RADIUS	3/8	TEAR SEAL	NATURAL EDGE
DATE		COMPLETED		BAR SEAL	484

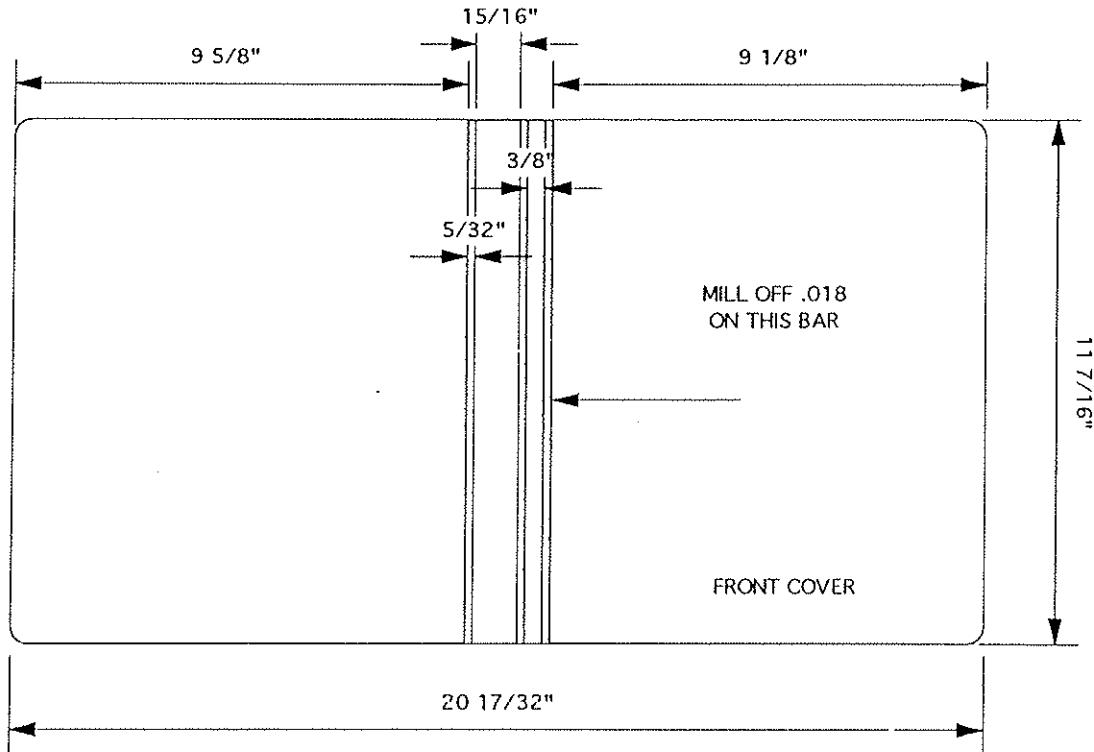

MATERIAL SPECS		GA	PCS	GA		PCS
COVER MATL	12 1/8 X 11 11/16	1	LINING	12 1/8 X 11 11/16	1	
20 GAUGE RIGID	12 1/8 X 9 5/8	1	LINING			
VERT PKT			HORZ PKT			
VERT PKT			HORZPKT			
CARD HOLDER			DIAGONAL PKT			
COL			LABEL HOLDER			
EX COL			GUSSETT			
			REINF			

BOARD SPECS					
F.C. BOARD			F.C. BOARD		
B.B. BOARD	11 3/8 x 27/32	1	B.B. BOARD		
B.C. BOARD			B.C. BOARD		
BU STRIP					

URB

DIE # 5650		STYLE CASE CHOIR FOLDER		LOCATION E 13-7	
SHEET SIZE 11 X 8 1/2 (Special Size)		CAP. 1"		ORDER # 68811	
CUSTOMER EBSCO MEDIA				DUE DATE 9-14-94	
QUANTITY	270	RADIUS	3/8	TEAR SEAL	.014
DATE	8-25-94	COMPLETED		BAR SEAL	48-4

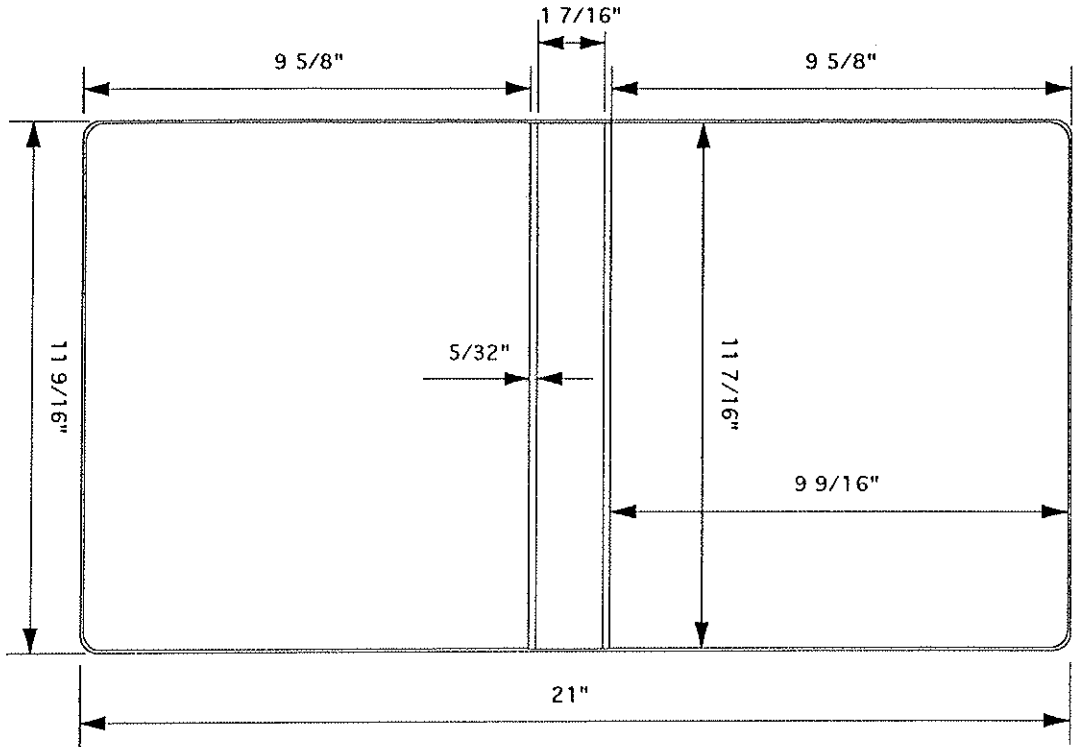

MATERIAL SPECS

GA PCS

GA PC

COVER MATL	12 5/16 X 21 3/4	1	LINING	12 5/16 X 21 3/4	1
COVER MATL			LINING		
VERT PKT	12 5/16 X 3 3/8	2	HORZ PKT		
VERT PKT			HORZPKT		
CARD HOLDER			DIAGONAL PKT		
COL			LABEL HOLDER		
EX COL			GUSSETT		
			REINF		

BOARD SPECS

GA PCS

F.C. BOARD	11 3/8 X 9 1/2	50	1	F.C. BOARD	
B.B. BOARD	11 3/8 X 1 11/32	50	1	B.B. BOARD	
B.C. BOARD	11 3/8 X 9 1/2	50	1	B.C. BOARD	
BU STRIP					

11
11
Overseer

DIE # 5668-A	STYLE CASE	STITCHED BINDER	LOCATION	E-14-8	
CUSTOMER	COLAD		ORDER #	979387	
SHEET SIZE	11 X 9	CAP	1 1/4	DUE DATE	9-28-94
QUANTITY	1	RADIUS	3/8	TEAR SEAL	.014
DATE	9-21-94	COMPLETED		BAR SEAL	48-3

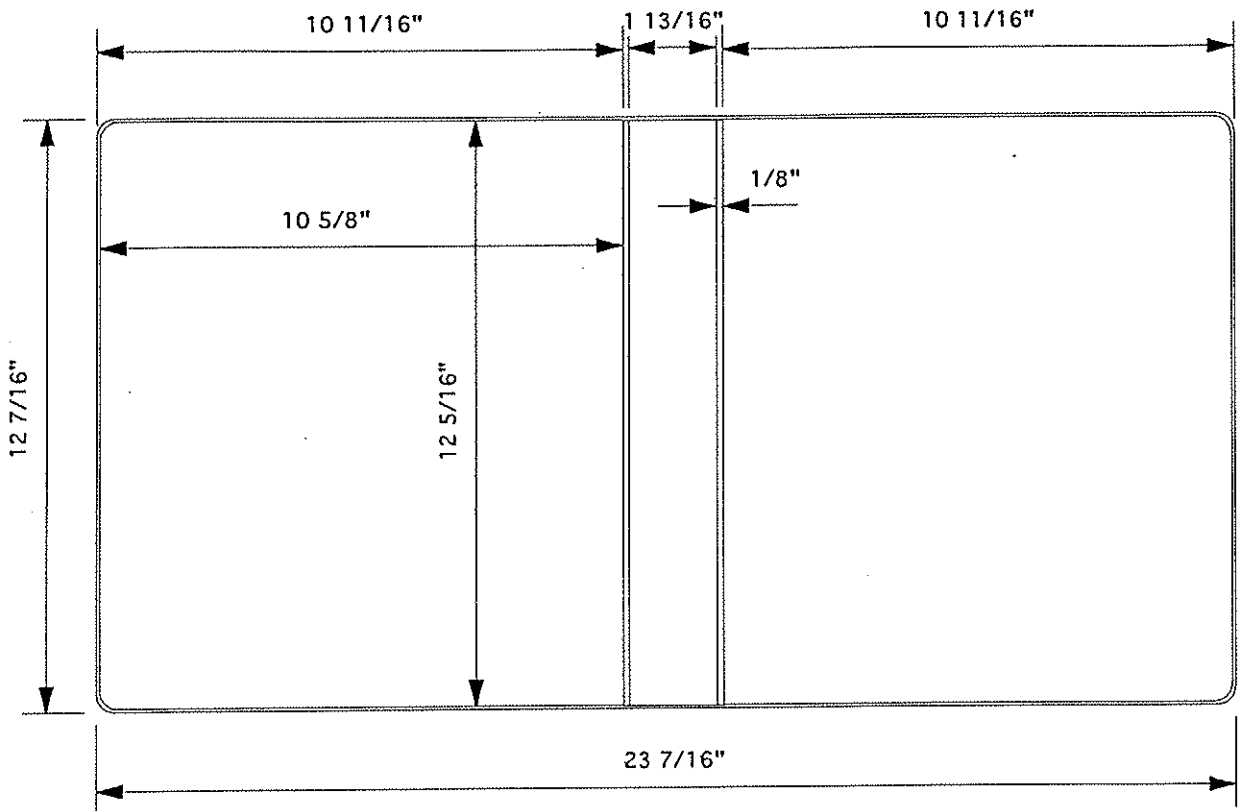

MATERIAL SPECS		GA	PCS	GA		PCS
COVER MAT.	13 7/16 X 24 7/16	1	LINING	13 5/16 X 24 5/16	1	
COVER MAT.			LINING			
VERT PKT.			HORZ PKT.			
CARD HOLDER			DIAGONAL PKT.	12 1/2 X 9 3/8	1	
COL			LABEL HOLDER	(POCKET 2 OUT)		
			DIE CUT POCKET			

BOARD SPECS		GA	PCS	GA		PCS
F.C. BOARD	12 1/4 X 10 9/16	100	1	DIE CUT BOARD	22 1/2 X 15 5/16	1
B.B. BOARD	12 1/4 X 1 3/4	100	1	B.C. BOARD	(PADDED)	
B.C. BOARD	12 1/4 X 10 9/16	100	1	B.C. BOARD		
B. UP STRIP						

DIE #	5694-A	CAP.	1	METAL	1" LOC
STYLE CASE	CAT BINDER			LOCATION	E-16-3
SHEET SIZE	11 X 8 1/2		ORDER #	979628	
CUSTOMER	LISA WEBB			DUE DATE	
QUANTITY	1	RADIUS		TEAR SEAL	.014
DATE	10-19-94	COMPLETED		BAR SEAL	48-4

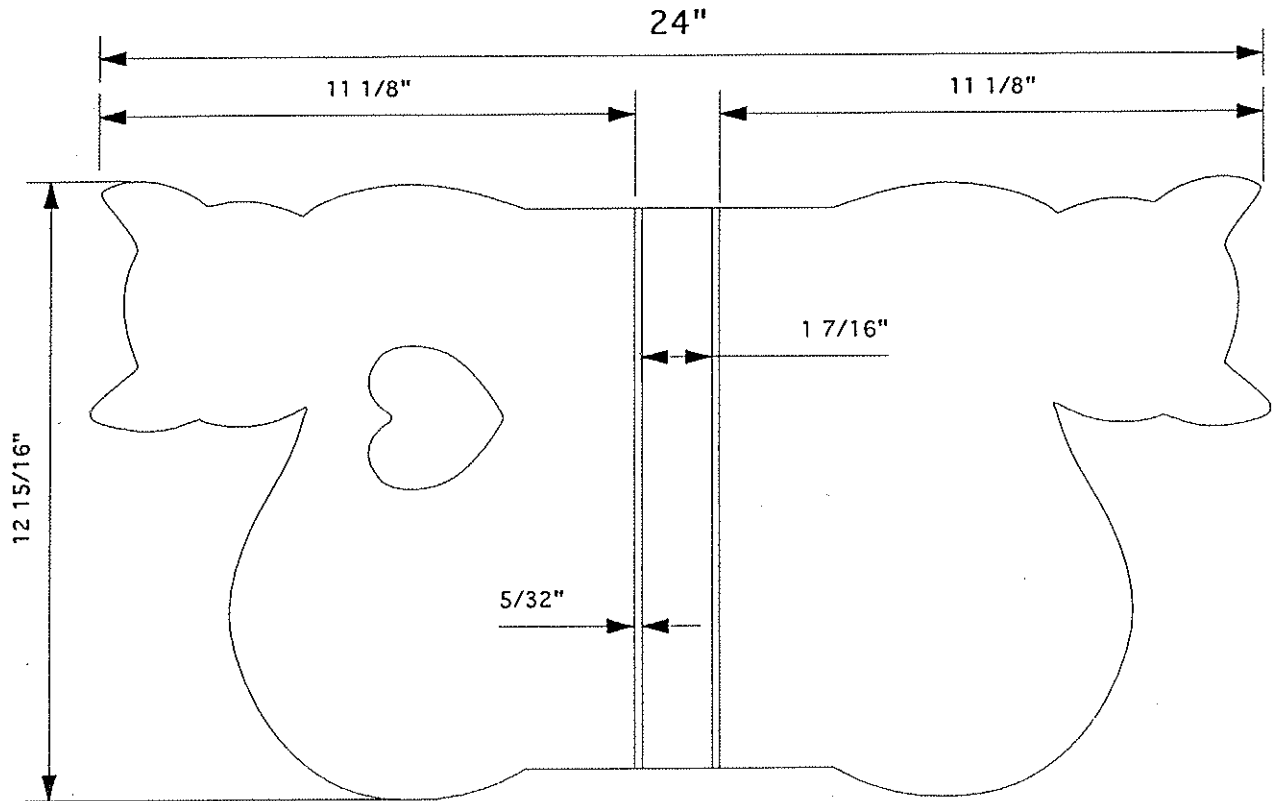

MATERIAL SPECS		GA		PCS		
COVER MAT.	13 7/8 X 25 1/4	1		LINING MAT	13 7/8 X 25 1/4	1
COVER MAT.				LINING MAT		
VERT PKT				HORZ PKT		
CARD HOLDER				GUSSET		
COL				DIAGONAL PKT		
LABEL HOLDER				REINF		
BOARD SPECS		GA		PCS		
DIE CUT BD	13 7/8 x 23 5/8	100	1	F.C. BOARD		
B.B. BOARD	11 17/32 X 1 11/32	100	1	B.B. BOARD		
B.C. BOARD				B.C. BOARD		
B.U. STRIP						

DIE #	5695-A	CAP.	1"	METAL	ST D NB IBC
STYLE CASE				LOCATION E-16-4	
SHEET SIZE 8 1/2 X 11			ORDER # 979628		
CUSTOMER LISA WEBB				DUE DATE 11-02-94	
QUANTITY	1	RADIUS		TEAR SEAL	.014
DATE	10-19-94	COMPLETED		BAR SEAL	48-4

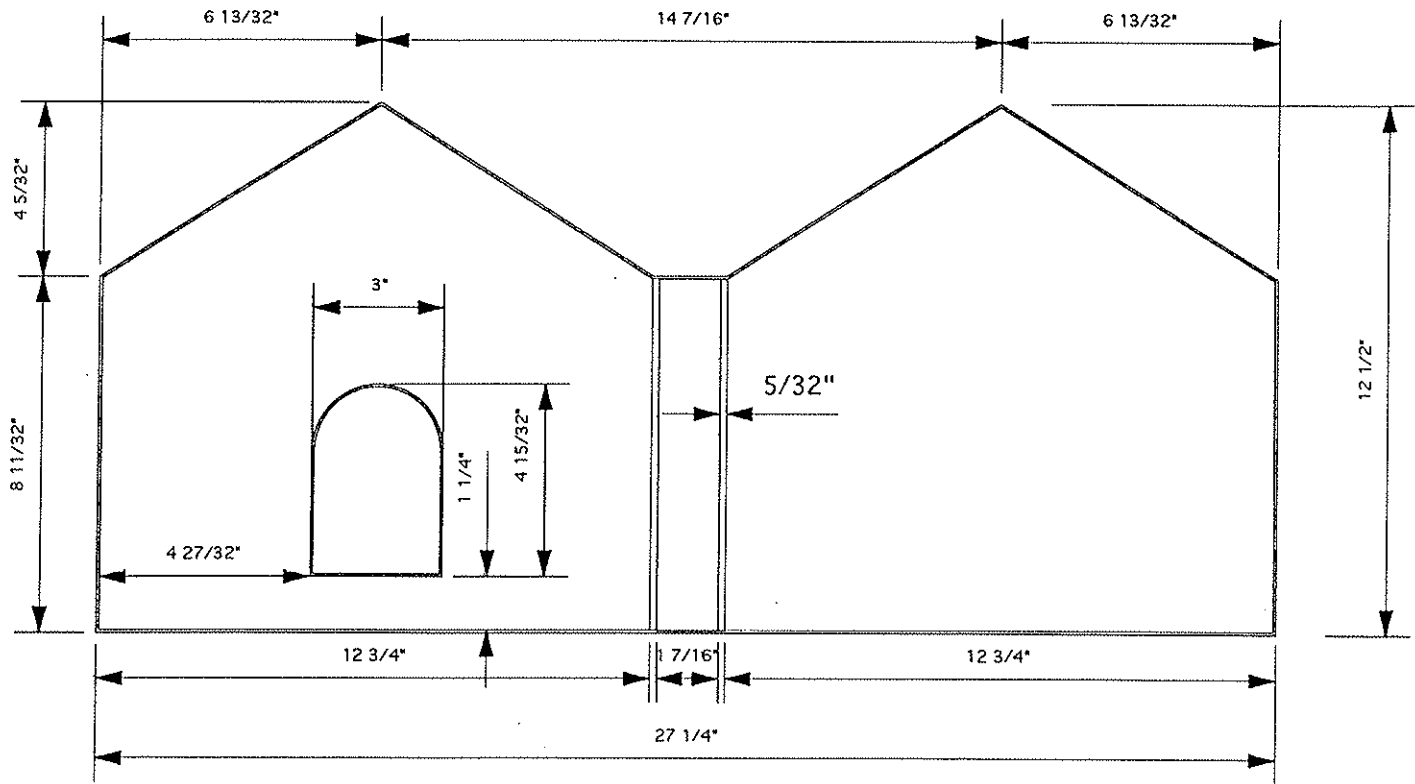

MATERIAL SPECS

GA PCS

GA PCS

COVER MAT.	13 1/4 X 28 7/8	1	LINING MAT	13 1/4 X 28 7/8	1
COVER MAT.			LINING MAT		
VERT PKT			HORZ PKT		
CARD HOLDER	4 5/8 X 5 1/4	1	GUSSET		
COL			DIAGONAL PKT		
LABEL HOLDER			REINF		

BOARD SPECS

GA PCS

GA PCS

F.C. BOARD			F.C. BOARD		
B.B. BOARD	8 5/32 X 1 3/8	120	B.B. BOARD		
B.C. BOARD			B.C. BOARD		
B.U. STRIP					

(Oversize Spine)

IE # 5709	CAP. 3	METAL 3" HOC
STYLE CASE VINYL RING BINDER	LOCATION E-17-1	
SHEET SIZE 11 X 8 1/2	ORDER #	
CUSTOMER		DUE DATE
QUANTITY	RADIUS 3/8	TEAR SEAL .014
DATE 11-07-94	COMPLETED	BAR SEAL 48-4

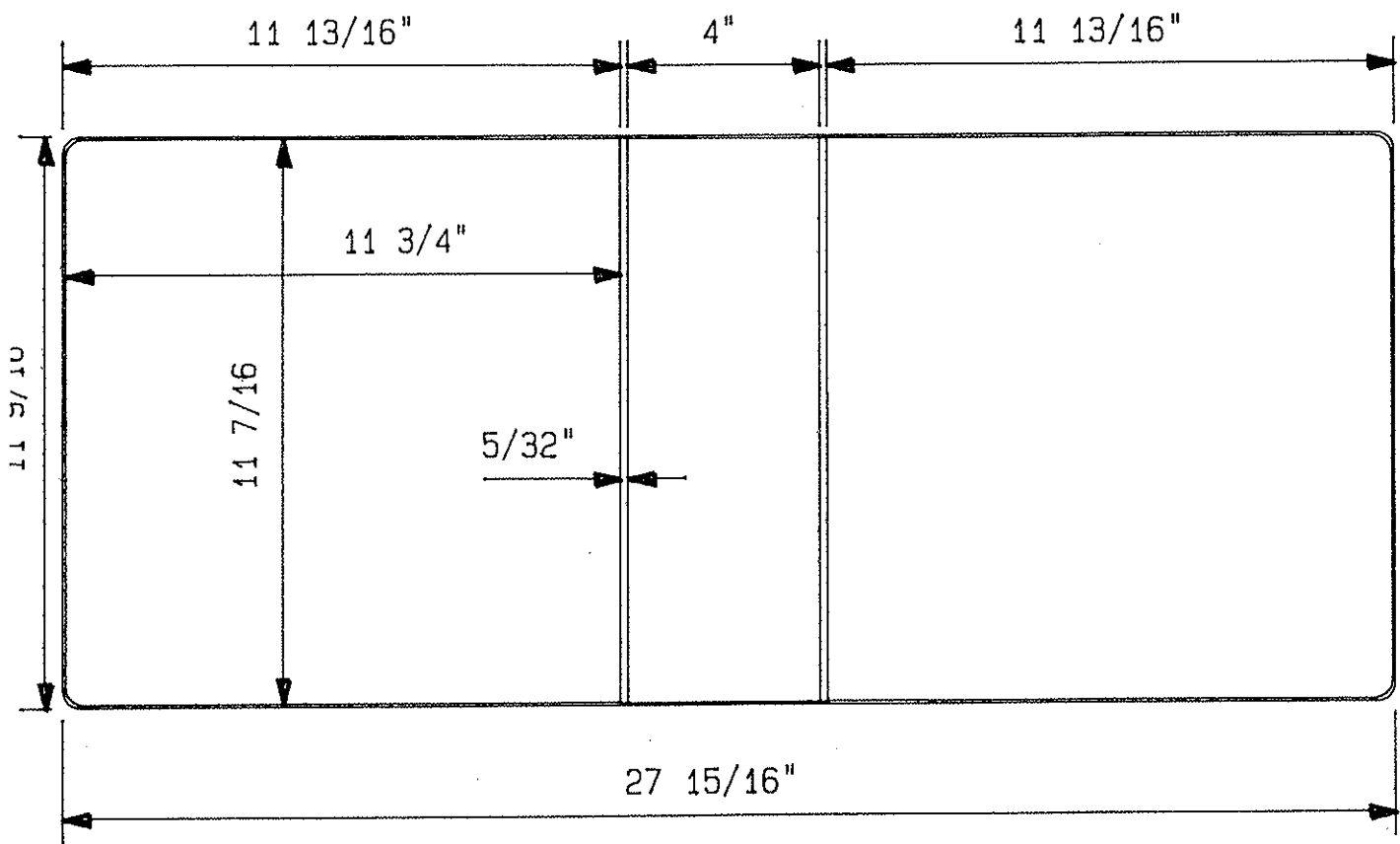

MATERIAL SPECS		GA	PCS	GA		PCS
COVER MAT.	12 5/16 X 28 3/4		1	LINING MAT	12 5/16 X 28 3/4	1
COVER MAT.				LINING MAT		
VERT PKT				HORZ PKT		
CARD HOLDER				GUSSET		
COL				DIAGONAL PKT		
LABEL HOLDER				REINF		
BOARD SPECS		GA	PCS	GA		PCS
F.C. BOARD	11 11/32 X 11 21/32	120	1	F.C. BOARD		
B.B. BOARD	11 11/32 X 3 29/32	120	1	B.B. BOARD		
B.C. BOARD	11 11/32 X 11 21/32	120	1	B.C. BOARD		
B.U. STRIP						

DIE #	5738	CAP.	2 7/8	METAL	Rigid Channel & Poly U Channel	
STYLE CASE	VINYL BINDER			LOCATION	E-18-2	
SHEET SIZE	11 X 9		ORDER #	980189		
CUSTOMER VALUE LINE PUBLISHING				DUE DATE	1-6-95	
QUANTITY	6	RADIUS	3/8	TEAR SEAL	.010	
DATE	12-23-94	COMPLETED		BAR SEAL	48-4	

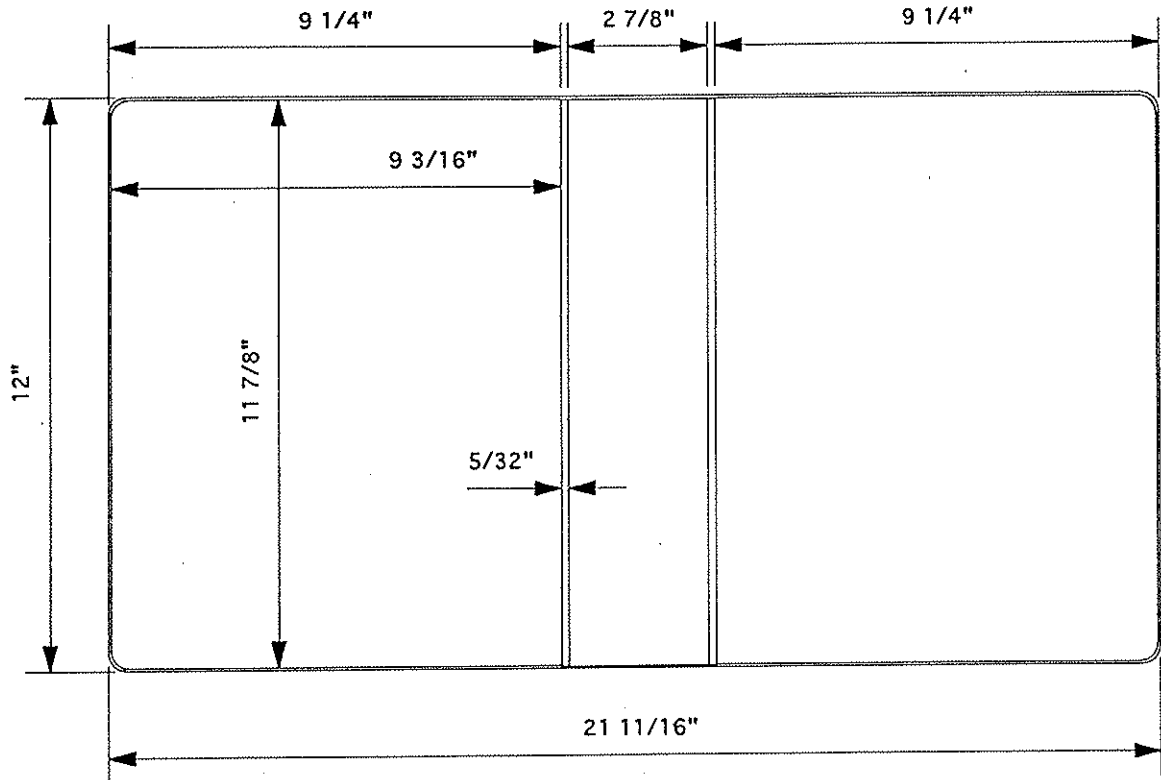

MATERIAL SPECS		GA	PCS			GA	PCS
COVER MAT.	12 3/4 X 22 7/16	1		LINING MAT	12 3/4 X 22 7/16	1	
COVER MAT.				LINING MAT			
VERT PKT				HORZ PKT	4 7/8 X 22 7/16	1	
CARD HOLDER				GUSSET			
COL				DIAGONAL PKT			
LABEL HOLDER				REINF	12 3/4 X 5	1	
BOARD SPECS		GA	PCS			GA	PCS
F.C. BOARD	11 13/16 X 9 1/8	100	1	F.C. BOARD			
B.B. BOARD	11 13/16 X 2 25/32	100	1	B.B. BOARD			
B.C. BOARD	11 13/16 X 9 1/8	100	1	B.C. BOARD			
B.U. STRIP							

DIE #	5769	CAP.	3"	METAL	LENARD K-LINE
STYLE CASE	VINYL BINDER			LOCATION	E-19-5
SHEET SIZE	11 X 9			ORDER #	980416
CUSTOMER	STANDARN OF LYNN			DUE DATE	2-10-95
QUANTITY	1000	RADIUS	3/8	TEAR SEAL	NAT EDGE
DATE	2-7-95	COMPLETED		BAR SEAL	48-4

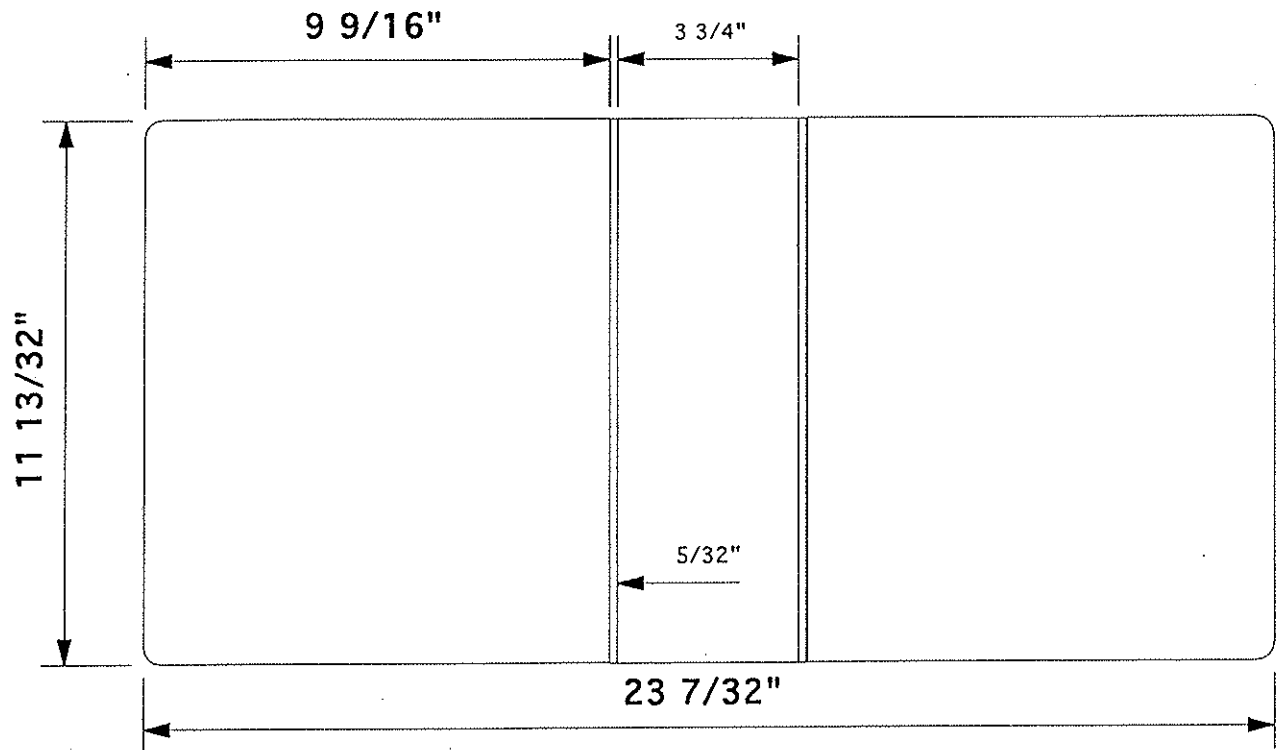

MATERIAL SPECS		GA	PCS			GA	PCS
COVER MAT.	12 1/4 X 24		1	LINING MAT	12 1/4 X 24		1
COVER MAT.				LINING MAT			
VERT PKT				HORZ PKT	5 3/8 X 24		1
CARD HOLDER				GUSSET			
COL	11 3/4 X 24		1	DIAGONAL PKT			
LABEL HOLDER				REINF			
BOARD SPECS		GA	PCS			GA	PCS
F.C. BOARD	11 1/4 X 9 7/16	120	1	F.C. BOARD			
B.B. BOARD	11 1/4 X 3 21/32	120	1	B.B. BOARD			
B.C. BOARD	11 1/4 X 9 7/16	120	1	B.C. BOARD			
B.U. STRIP							

DIE #	5807	METAL	3" SCREWPOST	RADIUS	3/8
ORDER #	981006	CUSTOMER	VALUELINE	TEAR SEAL	.010
SHEET SIZE	11 X 9	STYLE CASE	SCREWPOST BINDER	BAR SEAL	102 & 253
CAP.	3"	DUE DATE	3-24-95	COMPLETED	
LOCATION		QUANTITY	6	DATE	3-21-95

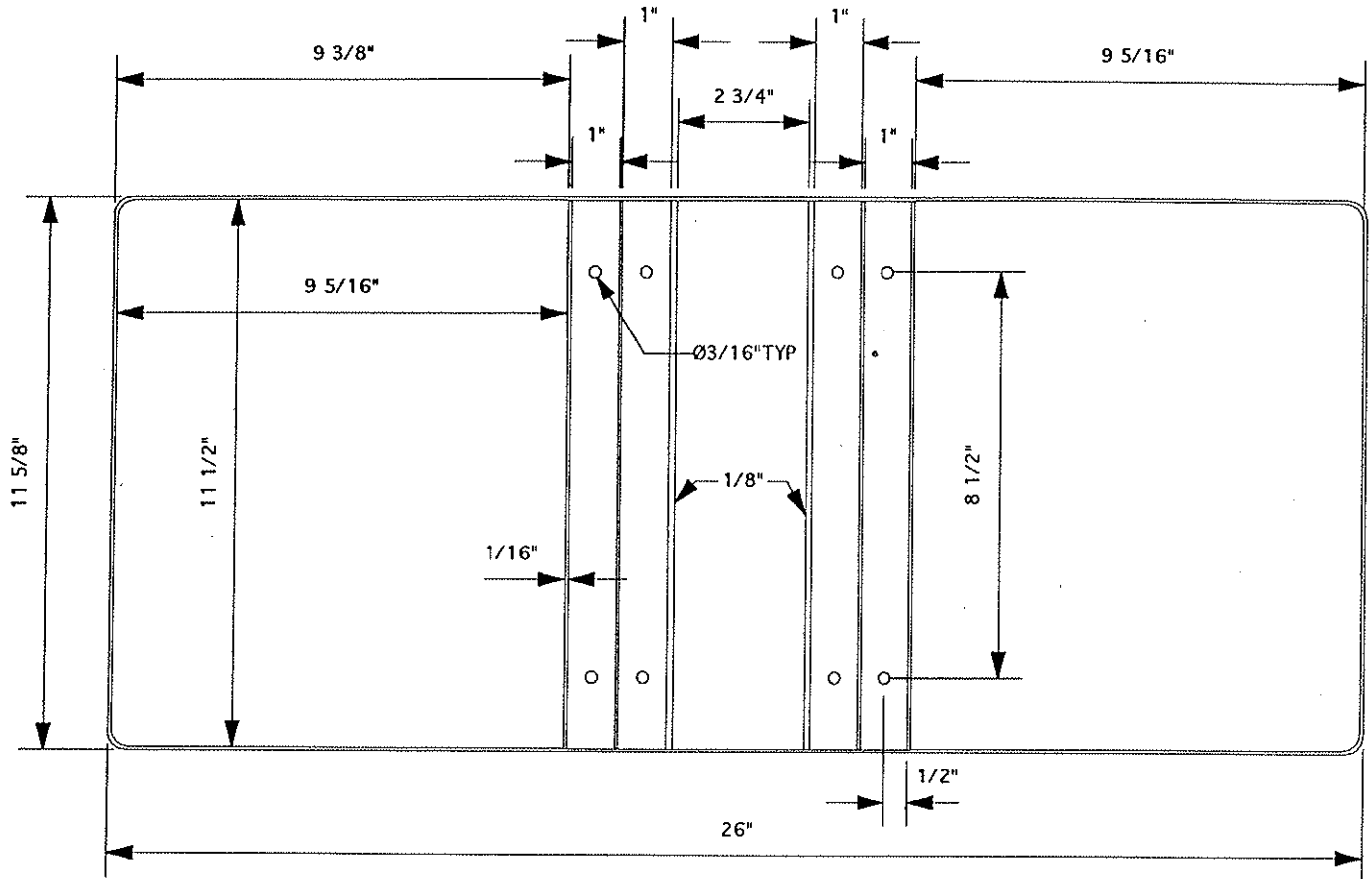

MATERIAL SPECS		GAUGE PCS.		MATERIAL SPECS		GAUGE PCS.	
COVER MAT.	12 3/8 x 26 3/4		1	LINING MAT.	12 3/8 x 26 3/4		1
COVER MAT.				LINING MAT.			
CARD HOLDER				HORZ. PKT.			
COL				VERT. PKT.			
LABEL HOLDER				DIAG. PKT			
GUSSET				REINF.			

BOARD SPECS		GAUGE PCS.		BOARD SPECS		GAUGE PCS.	
F.C. BOARD	11 7/16 x 9 1/4	100	1	F.C. BOARD			
B.B. BOARD	11 7/16 x 2 21/32	100	1	B.B. BOARD			
B.C. BOARD	11 7/16 x 9 1/4	100	1	B.C. BOARD			
B.U. STRIP				DIE CUT			
DIE CUT				DIE CUT			

Some as # 4351 except Beaded Edge

DIE #	5819	METAL	ROUND + ADVANTAGE ANGLE D	RADIUS	3/8
ORDER #	STOCK	CUSTOMER	NATIONS BANK	TEAR SEAL	.012
SHEET SIZE	11 X 9	STYLE CASE	1 UP VERSION OF STOCK FIAB DIE 5172	BAR SEAL	484
CAP.	3"	DUE DATE	<i>Beaded Edge</i>	COMPLETED	
LOCATION	X-1-3	QUANTITY		DATE	4-10-95

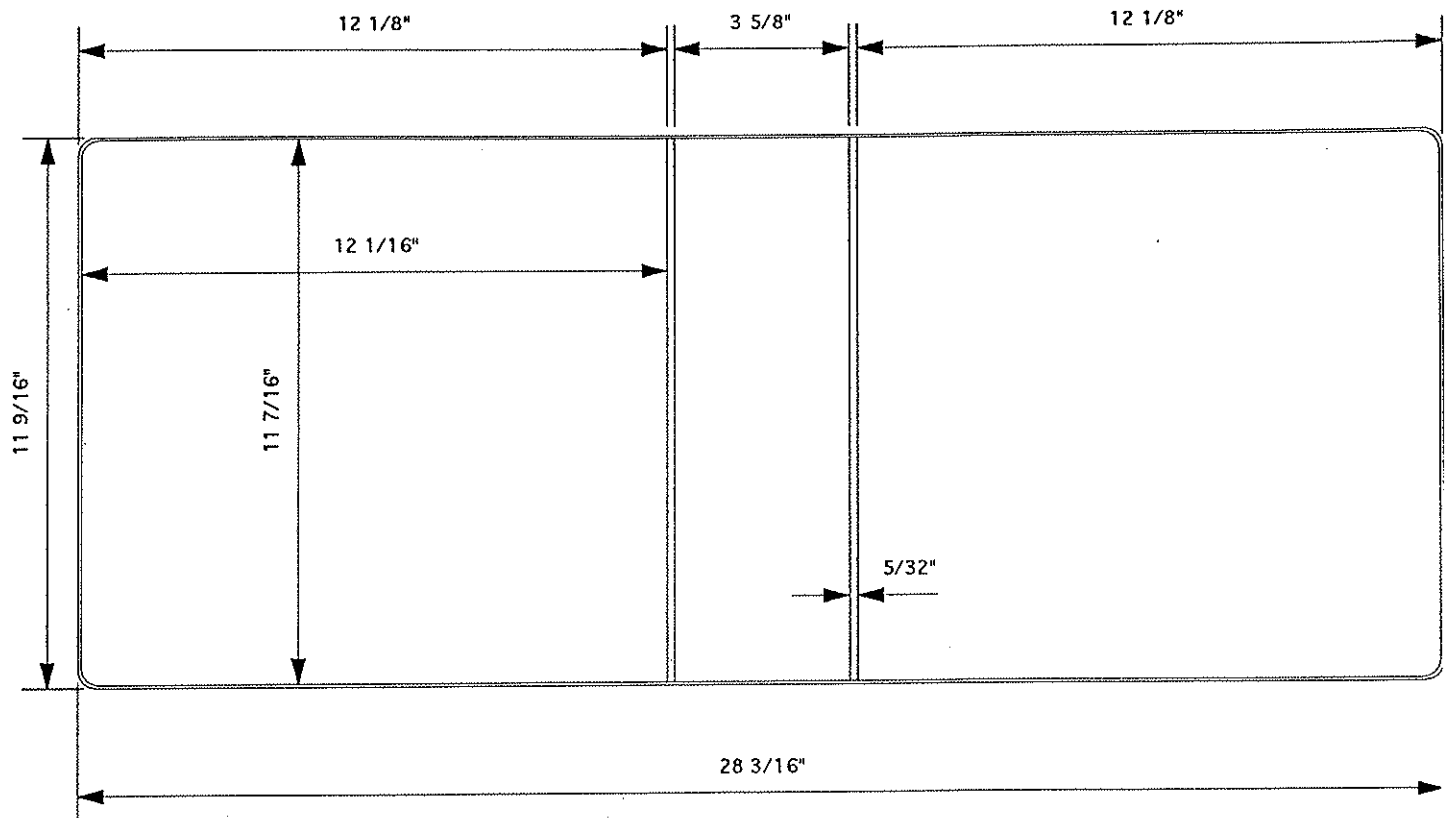

MATERIAL SPECS		GAUGE PCS.		MATERIAL SPECS		GAUGE PCS.	
COVER MAT.	12 3/8 X 29		1	LINING MAT.	12 3/8 X 29		
COVER MAT.				LINING MAT.			
CARD HOLDER				5" HORZ. FULL PKT	5 3/8 X 29		
COL	11 3/4 X 29		1	4 1/2" HORZ. FULL PKT	4 7/8 X 29		
EX COL	11 3/4 X 17		1	5" HORZ. PKT. 1 SIDE	5 3/8 X 12 5/8		
EX COL NO TRIM	11 3/4 X 16 7/16		1	4 1/2" HORZ. PKT. 1 SIDE	4 7/8 X 12 5/8		
BOARD SPECS		GAUGE PCS.		BOARD SPECS		GAUGE PCS.	
<i>033461</i> F.C. BOARD	11 11/32 X 11 31/32	033461	120 1	F.C. BOARD			
<i>025462</i> B.B. BOARD	11 11/32 X 3 17/32	035462	120 1	B.B. BOARD			
B.C. BOARD	11 11/32 X 11 31/32		120 1	B.C. BOARD			
B.U. STRIP				DIE CUT			
DIE CUT				DIE CUT			

Clear Front

DIE #	5944	METAL	LOC NARROW BASE	RADIUS	3/8
ORDER #	982964	CUSTOMER	HOLT RINEHART & WINSTON	TEAR SEAL	.014
SHEET SIZE	11 X 9	STYLE CASE	VINYL RING BINDER	BAR SEAL	178 - 254
CAP.	1"	DUE DATE	11-07-95	COMPLETED	
LOCATION		QUANTITY	3	DATE	10-31-95

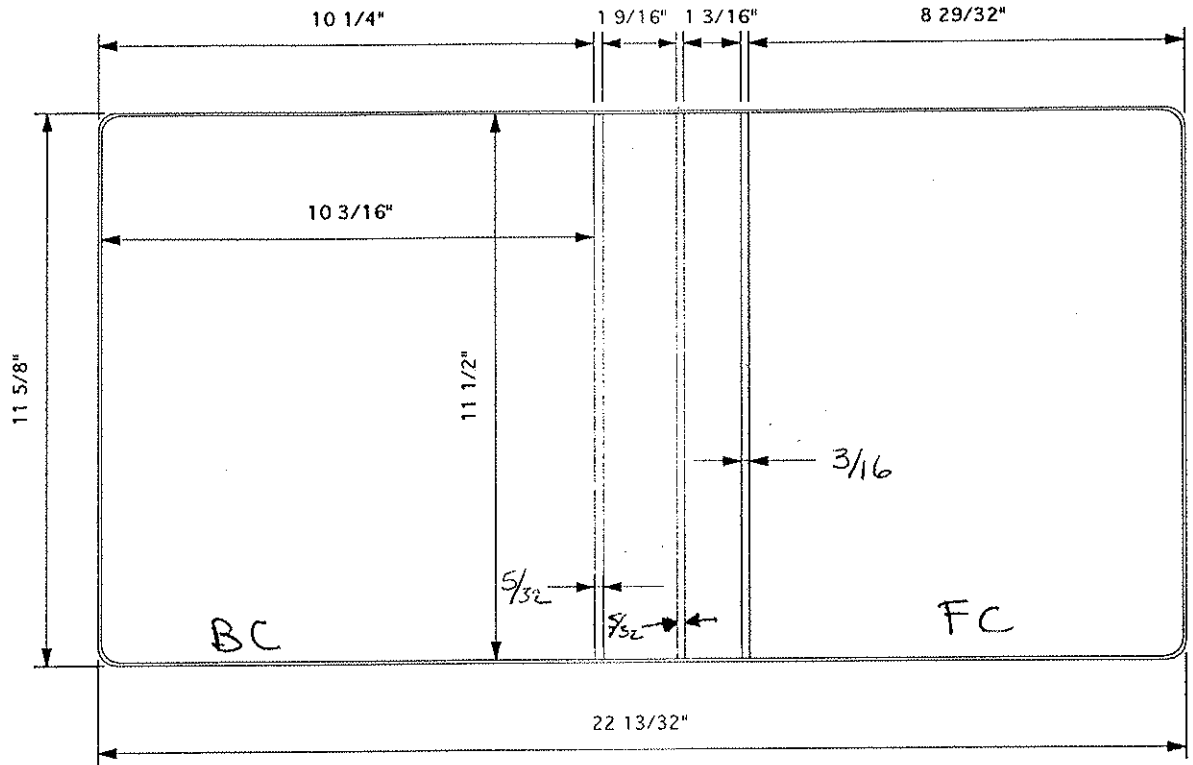

1 up

MATERIAL SPECS		GAUGE		PCS.		MATERIAL SPECS		GAUGE	
COVER MAT.	12 3/8 X 14			1		LINING MAT.	12 3/8 X 14		
COVER MAT.	12 3/8 X 9 3/8	.016	CLEAR	1		LINING MAT.			
DIE CUT						HORZ. PKT.			
COL						VERT. PKT.			
LABEL HOLDER	3 3/8 X 1 15/16			1		DIE CUT			
GUSSET						REINF.			

BOARD SPECS		GAUGE		PCS.		BOARD SPECS		GAUGE	
F.C. BOARD	NONE					F.C. BOARD			
B.B. BOARD	11 7/16 X 1 15/32	100		1		B.B. BOARD			
B.C. BOARD	11 7/16 X 10 1/8	100		1		B.C. BOARD			
B.B. BOARD	11 7/16 X 1 3/32	100		1		DIE CUT			
B.U. STRIP	11 3/8 X 1 13/32	35		1		DIE CUT			

Matched Sample

DIE #	5946	METAL	HOC	RADIUS	3/8
ORDER #	982972	CUSTOMER	THOMPSON PUBLISHING	TEAR SEAL	.014
SHEET SIZE	11 X 9	STYLE CASE	VRB	BAR SEAL	254
CAP.	2"	DUE DATE	11-3-95	COMPLETED	
LOCATION		QUANTITY	1000	DATE	11-1-95

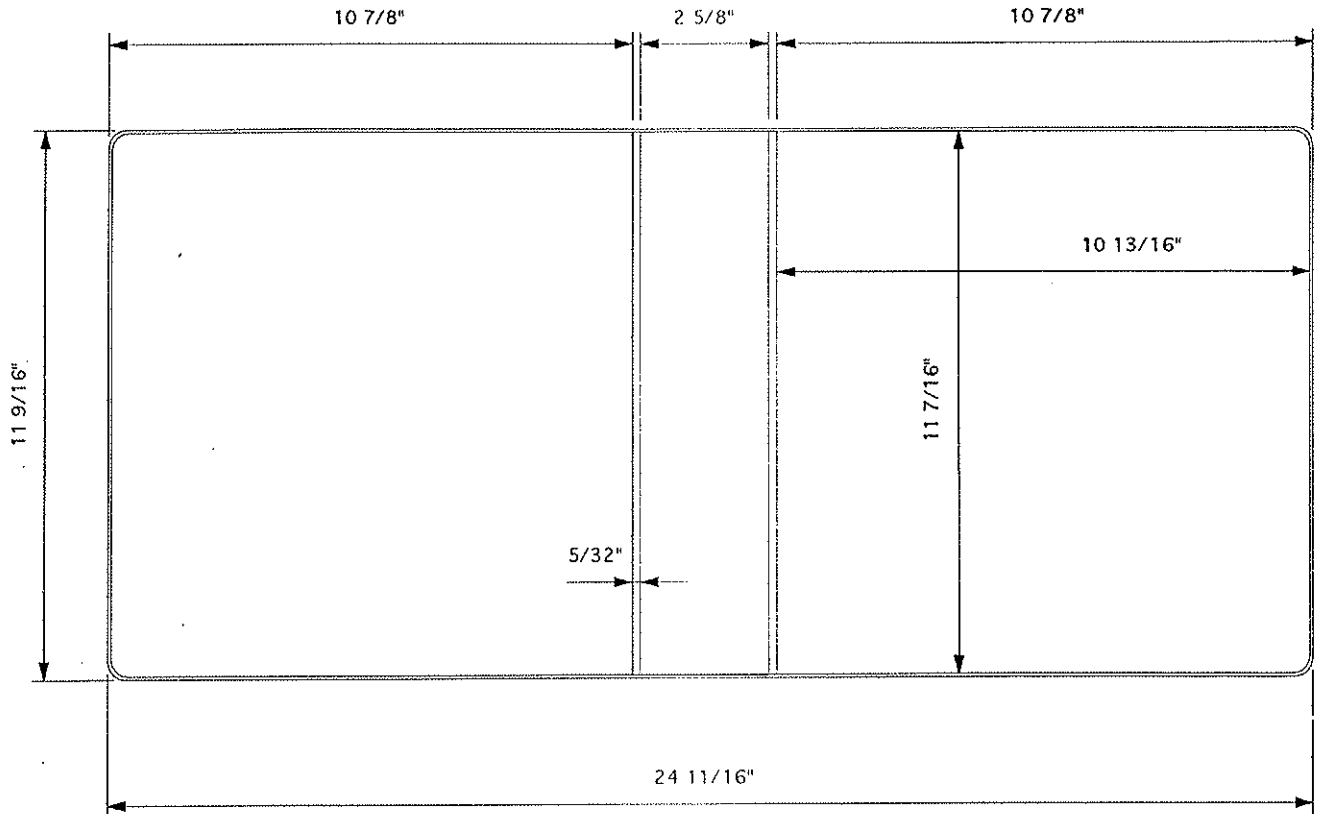

MATERIAL SPECS		GAUGE		PCS.		MATERIAL SPECS		GAUGE	
COVER MAT.	12 1/4 X 25 7/16			1		LINING MAT.	12 1/4 X 25 7/16		
COVER MAT.						LINING MAT.			
DIE CUT						HORZ. PKT.	5 3/8 X 11 3/8		
COL						VERT. PKT.			
LABEL HOLDER	2 7/8 X 3			1		DIE CUT			
GUSSET						REINF.			

BOARD SPECS		GAUGE		PCS.		BOARD SPECS		GAUGE	
F.C. BOARD	11 11/32 X 10 23/32	120	1	1		F.C. BOARD			
B.B. BOARD	11 11/32 X 2 17/32	120	1	1		B.B. BOARD			
B.C. BOARD	11 11/32 X 10 23/32	120	1	1		B.C. BOARD			
B.U. STRIP						DIE CUT			
DIE CUT						DIE CUT			