



Product Code

Style Case *Ring Binder*

Sheet Size *11 X 11/2* Cap. *2* Die No. *7217* Order No. *36114-7* Plate

Customer

*Data Supplies, Inc.*

Metal
Total Vinyl .030
Quantity 50
Date 11/10/78
Type Corners <i>Rd</i>
Radius <i>1/4</i>
Completed

	Gauge	Thick
Tear Seal	.016	3/32
Bar Seal	172	3/16
Bar Seal		

	No. of Feet
Tear Seal	6 1/2
Bar Seal	2
Bar Seal	

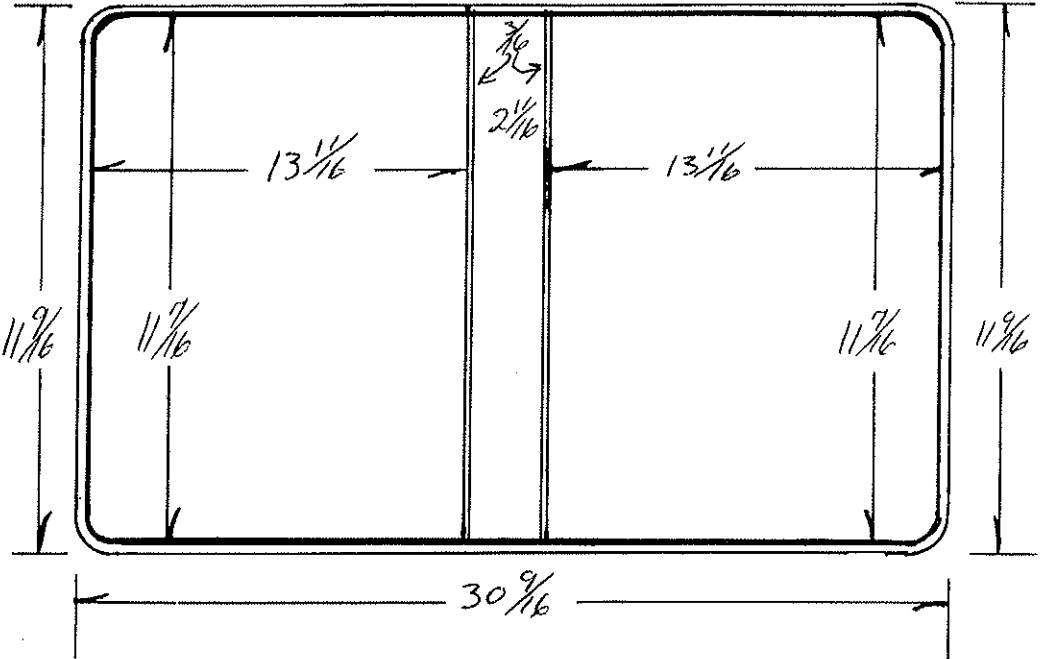

Code	Ga.	# PCS	Cutting Specs		Code	Ga.	# Pcs.	Cutting Specs	
			Size	Out				Size	Out
Cover Mat.			12 3/16 X	3 5/16	Lining Mat.			12 3/16 X	3 5/16
Cover Mat.			X		Lining Mat.			X	
Vert. Pckt.			X		Horz. Pckt.			X	
Vert. Pckt.			X		Horz. Pckt.			X	
Pocket			X		Pocket			X	
Label Holder			X		Card Hlder			X	
Material			X		Material			X	
Material			X		Material			X	
Material			X		Material			X	
F.C. Board			11 1/32 X	13 19/32	B.C. Board			11 1/32 X	13 19/32
B.G. Board			11 3/8 X	13 5/8	B.B. Board			11 1/32 X	2 1/32
Center Board			X		Board			11 3/8 X	2 19/32
Board			X		Strip			X	
Cover Pad			X		Strip			X	
					B.B. Pad			X	

Product Code

Style Case *King Binder*

Sheet Size *11 X 14 1/2* Cap. *3*

Die No. *2227*

Order No. *36313-5*

Plate

*Milt Whytzell (Spillage)*

Customer

Metal
Total Vinyl <i>1130</i>
Quantity <i>100</i>
Date <i>11-27-98</i>
Type Corners <i>RD</i>
Radius <i>1/4</i>
Completed

	Gauge	Thick
Tear Seal	<i>.016</i>	<i>3/32</i>
Bar Seal	<i>175</i>	<i>7/16</i>
Bar Seal		

	No. of Feet
Tear Seal	<i>8</i>
Bar Seal	<i>2</i>
Bar Seal	

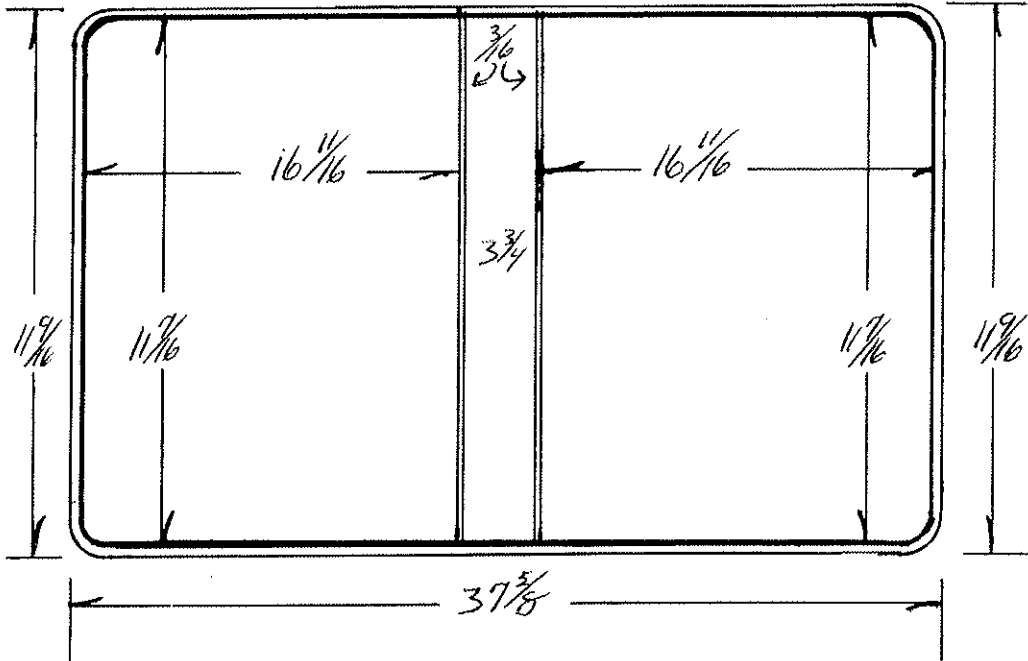

*Back bone bars  
milled down .006  
Finished height .922*

Code	Ga.	#	PCS	Cutting Specs		Code	Ga.	#	PCS	Cutting Specs	
				Size	Out					Size	Out
Cover Mat.			<i>1</i>	<i>12 3/16 X 38 3/8</i>		Lining Mat.			<i>1</i>	<i>12 3/16 X 38 3/8</i>	
Cover Mat				X		Lining Mat.				X	
Vert. Pckt.				X		Horz. Pckt.				X	
Vert. Pckt.				X		Horz. Pckt.				X	
Pocket				X		Pocket				X	
Label Holder				X		Card Holder				X	
Material				X		Material				X	
Material				X		Material				X	
Material				X		Material				X	
F.C. Board			<i>1</i>	<i>11 11/32 X 16 19/32</i>		B.C. Board			<i>1</i>	<i>11 11/32 X 16 19/32</i>	
B.C. Board				X		B.B. Board			<i>1</i>	<i>11 11/32 X 3 3/32</i>	
Center Board				X		Board				X	
Board				X	<i>ny lon</i>	Strip			<i>1</i>	<i>11 5/16 X 5 1/8</i>	
Cover Pad				X		Strip				X	
						B.B. Pad				X	

Product Code

Style Case Ring binder

Sheet Size 11 X 15 1/2 Cap. 1 1/2 Die No. 2703 Order No. 1669-1 Plate

Customer Phoenix Commercial Printers

Customer
Metal
Total Vinyl <u>1030</u>
Quantity <u>32</u>
Date <u>9-11-81</u>
Type Corners <u>Rd</u>
Radius <u>1/4</u>
Completed

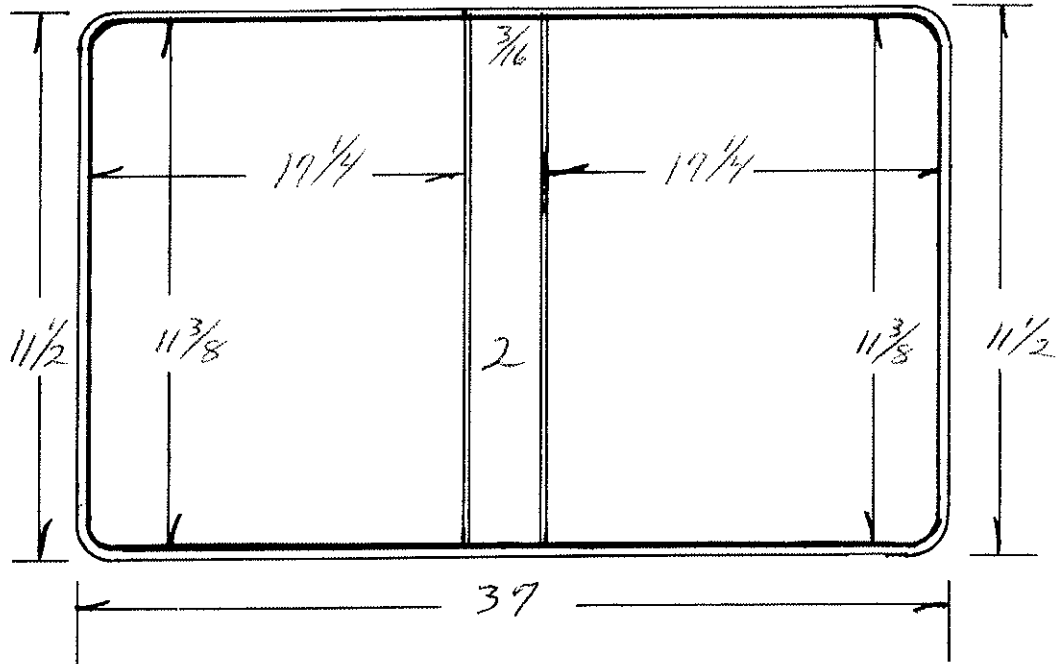

	Gauge	Thick
Tear Seal	<u>1016</u>	<u>352</u>
Bar Seal	<u>175</u>	<u>316</u>
Bar Seal		

	No. of Feet
Tear Seal	
Bar Seal	
Bar Seal	

Code	Ga.	# PCS	Cutting Specs		Code	Ga.	# Pcs.	Cutting Specs	
			Size	Out				Size	Out
Cover Mat.		<u>1</u>	<u>12 1/8 X 37 3/4</u>		Lining Mat.		<u>1</u>	<u>12 1/8 X 37 3/4</u>	
Cover Mat			X		Lining Mat.			X	
Vert. Pckt.			X		Horz. Pckt.			<u>5 3/8 X 18</u>	
Vert. Pckt.			X		Horz. Pckt.			<u>5 3/8 X 37 3/4</u>	
Pocket			X		Pocket			X	
Label Holder			X		Card Hlder			X	
Material			X		Material			X	
Material			X		Material			X	
Material			X		Material			X	
F.C. Board		<u>1</u>	<u>11 9/32 X 17 5/32</u>		B.C. Board		<u>1</u>	<u>11 9/32 X 17 5/32</u>	
B.C. Board			X		B.B. Board		<u>1</u>	<u>11 9/32 X 17 5/32</u>	
Center Board			X		Board			X	
Board			X		Strip			X	
Cover Pad			X		Strip			X	
					B.B. Pad			X	

Product Code P.M.

Style Case Ring Binder

Sheet Size 11 X 11 1/2 Cap. 1/2 Die No. 3349

Order No. 948184 Plate

Customer

Korn Ind.

5/31/85

Metal
Total Vinyl <u>.030</u>
Quantity <u>2000</u>
Date <u>6-12-85</u>
Type Corners <u>Rd</u>
Radius <u>1/4</u>
Completed

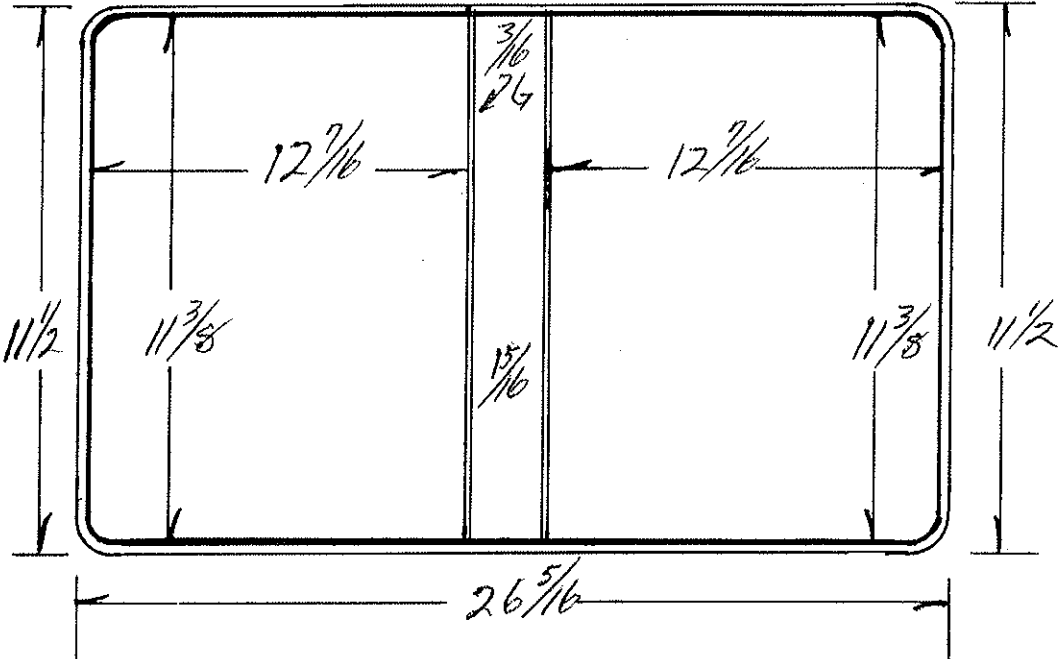

	Gauge	Thick
Tear Seal	<u>.016</u>	<u>3/32</u>
Bar Seal	<u>178</u>	<u>3/16</u>
Bar Seal		

	No. of Feet
Tear Seal	
Bar Seal	
Bar Seal	

Code	Ga.	# PCS	Cutting Specs		Code	Ga.	# Pcs.	Cutting Specs	
			Size	Out				Size	Out
Cover Mat.			<u>12 1/8 X</u>	<u>27 1/16</u>					
		<u>1</u>			Lining Mat.			<u>12 1/8 X</u>	<u>27 1/16</u>
Cover Mat.			X		Lining Mat.			X	
Vert. Pckt.			X		Horz. Pckt.			X	
Vert. Pckt.			X		Horz. Pckt.			X	
Pocket			X		Pocket			X	
Label Holder			X		Card Holder			X	
Material			X		Material			X	
Material			X		Material			X	
Material			X		Material			X	
F.C. Board			<u>11 9/32 X</u>	<u>12 1/32</u>	B.C. Board			<u>11 9/32 X</u>	<u>12 1/32</u>
		<u>1</u>							<u>1</u>
B.C. Board			X		B.B. Board			<u>11 9/32 X</u>	<u>2 3/32</u>
									<u>1</u>
Center Board			X		Board			X	
Board			X		Strip			X	
Cover Pad			X		Strip			X	
					B.B. Pad			X	

Product Code

Style Case Ring Binder

Sheet Size 11 1/2 X 10

Cap. 2 overall F.C.

Die No. 3404

Order No. 949843

Plate

TRW Space System

Customer

Metal
Total Vinyl <u>.030</u>
Quantity <u>100</u>
Date <u>10-29-85</u>
Type Corners <u>RD</u>
Radius <u>1/4</u>
Completed

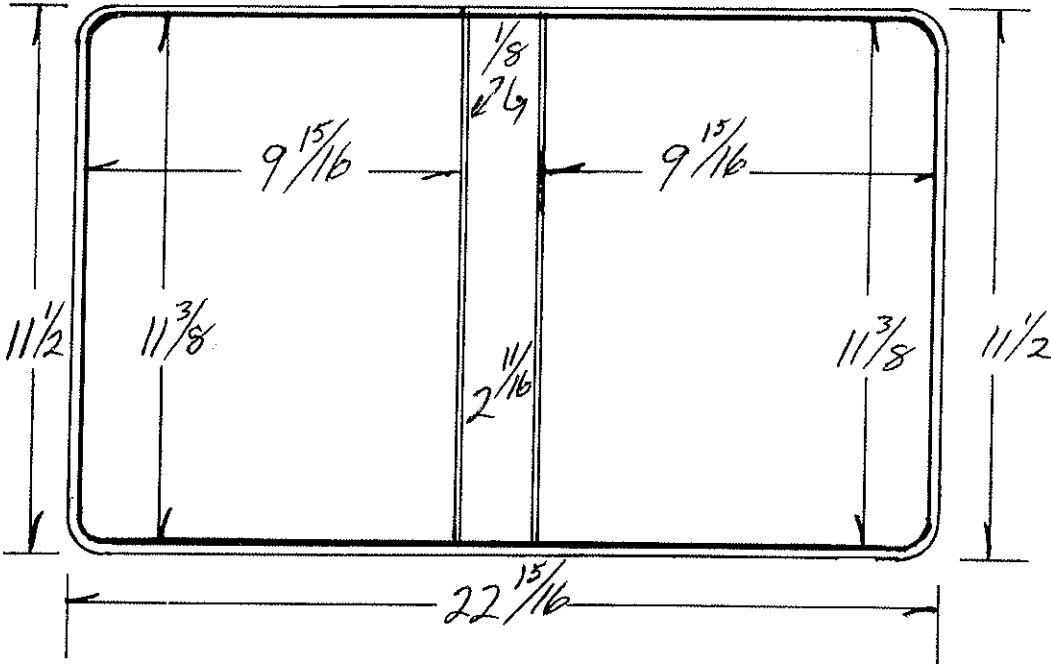

	Gauge	Thick
Tear Seal	<u>.016</u>	<u>3/32</u>
Bar Seal	<u>253</u>	<u>1/8</u>
Bar Seal		

	No. of Feet
Tear Seal	
Bar Seal	
Bar Seal	

Code	Ga.	Pcs	Cutting Specs		Code	Ga.	Pcs	Cutting Specs	
			Size	Out				Size	Out
Cover Mat.			<u>12 1/8 X 23 1/16</u>		Lining Mat.			<u>12 1/8 X 23 1/16</u>	
Cover Mat			X		Lining Mat.			X	
Vert. Pckt.			<u>11 5/8 X 23 1/16</u>		Horz. Pckt.			X	
Vert. Pckt.			X		Horz. Pckt.			X	
Pocket			X		Pocket			X	
Label Holder			X		Card Holder			X	
Material			X		Material			X	
Material			X		Material			X	
Material			X		Material			X	
F.C. Board			<u>11 9/32 X 9 27/32</u>	<u>1</u>	B.C. Board			<u>11 9/32 X 9 27/32</u>	<u>1</u>
B.C. Board			X		B.B. Board			<u>11 9/32 X 2 1/32</u>	<u>1</u>
Center Board			X		Board			X	
Board			X		Strip			X	
Cover Pad			X		Strip			X	
					B.B. Pad			X	

DIE #	3808-R	METAL	ANGLE D	RADIUS	3/8"
ORDER #	742629	CUSTOMER	CARDINAL BRANDS	TEAR SEAL	.014
SHEET SIZE	11 X 17 1/2	STYLE CASE	VINYL BINDER	BAR SEAL	48-4
CAP.	2"	DUE DATE	7-31-06	COMPLETED	
LOCATION		QUANTITY	3000	DATE	7-14-06

\*\*\* WARNING DRAWING NOT ACTUAL SIZE \*\*\*

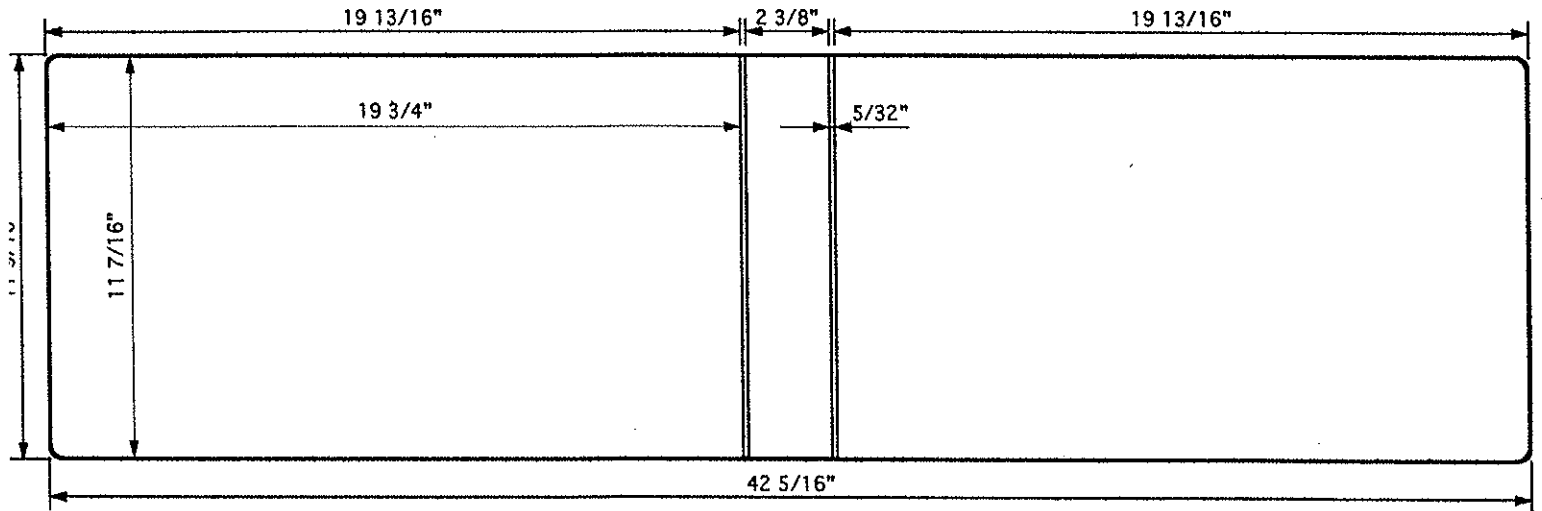

MATERIAL SPECS		GAUGE	PCS.	MATERIAL SPECS		GAUGE	PCS.
COVER MAT.	12 5/16 X 43 1/8		1	LINING MAT.	12 5/16 X 43 1/8		1
COVER MAT.				LINING MAT.			
DIE CUT				HORZ. PKT.			
COL				VERT. PKT.			
LABEL HOLDER				DIE CUT			
GUSSET				REINF.			

BOARD SPECS		GAUGE	PCS.	BOARD SPECS		GAUGE	PCS.
F.C. BOARD	11 11/32 X 19 21/32	150	1	F.C. BOARD			
B.B. BOARD	11 11/32 X 2 9/32	150	1	B.B. BOARD			
B.C. BOARD	11 11/32 X 19 21/32	150	1	B.C. BOARD			
FLAP BD.				DIE CUT			
BOARD				DIE CUT			

Product Code

Style Case VRB

Sheet Size 11 X 15 5/8 Cap. 2

Die No. 3926

Order No. 957377

Plate

Customer Farah Manufacturing

Metal
Total Vinyl
Quantity
Date
Type Corners <u>Rd</u>
Radius <u>1/4</u>
Completed

	Gauge	Thick
Tear Seal	<u>16</u>	<u>1/32</u>
Bar Seal	<u>16</u>	
Bar Seal		

	No. of Feet
Tear Seal	
Bar Seal	
Bar Seal	

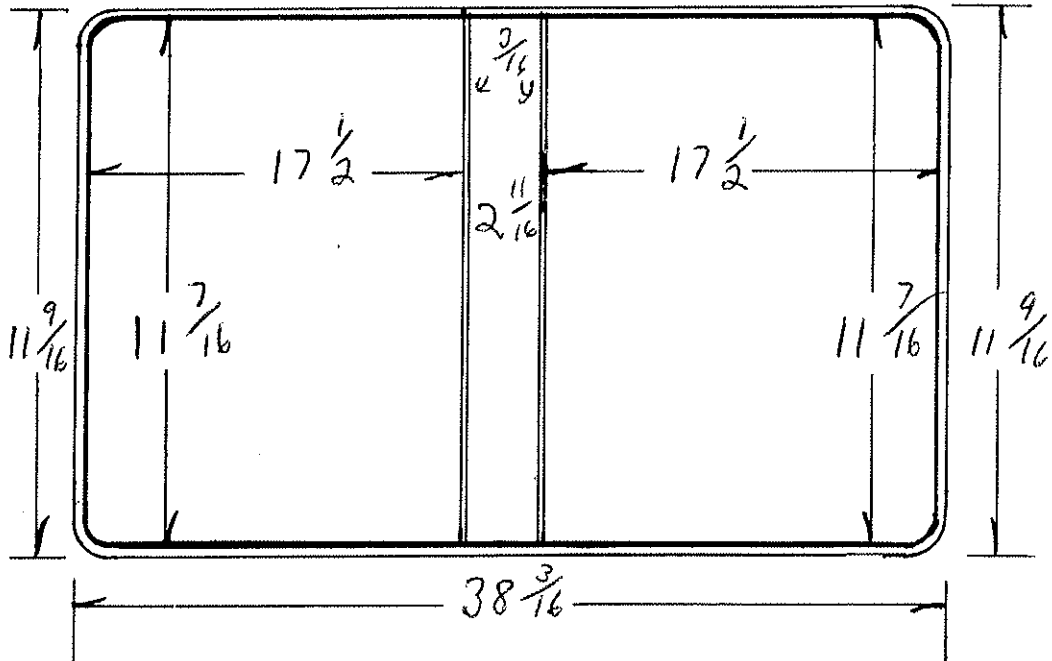

Code	Ga.	PCS	Cutting Specs		Code	Ga.	Pcs.	Cutting Specs	
			Size	Out				Size	Out
Cover Mat.		1	12 1/4 X 38 15/16		Lining Mat.	1	12 1/4 X 38 15/16		
Cover Mat.	X				Lining Mat.	X			
Vert. Pckt.	X				Horz. Pckt.		5 3/8 X 18		
Vert. Pckt.	X				Horz. Pckt.		5 3/8 X 38 15/16		
Pocket	X				Pocket	X			
Label Holder	X				Card Holder	X			
Material	X				Material	X			
Material	X				Material	X			
Material	X				Material	X			
F.C. Board		1	11 1/2 X 17 13/32		B.C. Board	1	11 1/2 X 17 13/32		
B.C. Board	X				B.B. Board	1	11 1/2 X 2 1/2		
Center Board	X				Board	X			
Board	X				Strip	X			
Cover Pad	X				Strip	X			
					B.B. Pad	X			



Product Code

Style Case

VRB

Sheet Size 11 x 11 1/2 Cap. 1 1/2 Die No. 4160 Order No. 58970.1 Plate

Customer NSC

Metal
Total Vinyl
Quantity
Date 3-9-89
Type Corners RND
Radius 3/8"
Completed

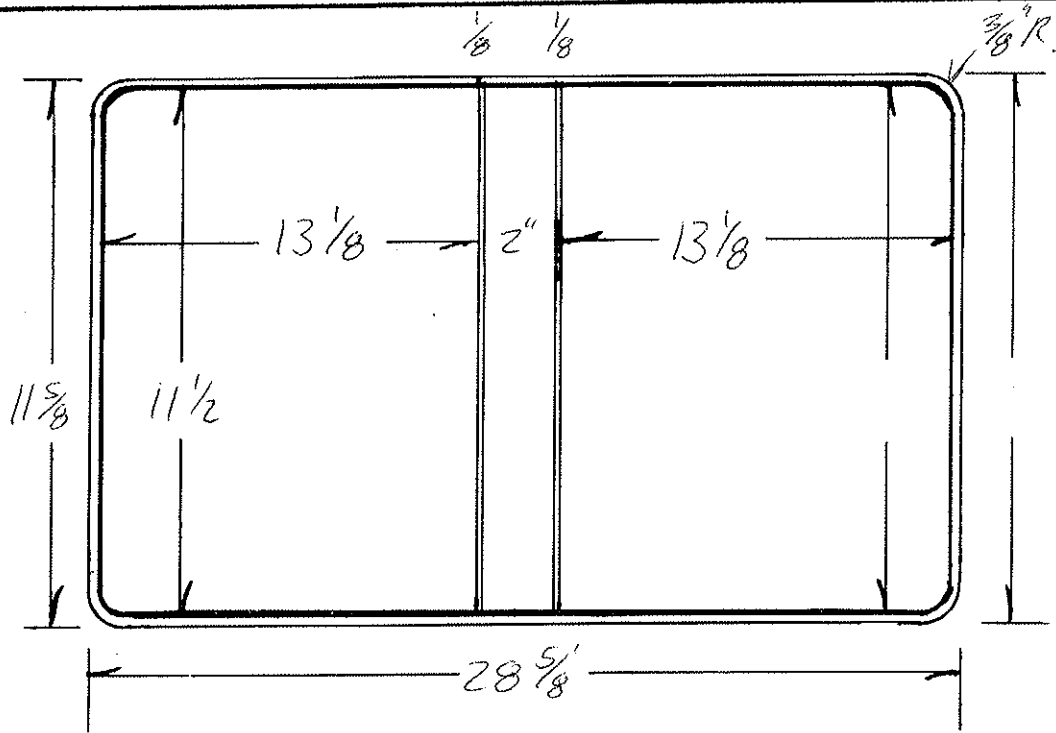

	Gauge	Thick
Tear Seal	16	3/32
Bar Seal		1/8
Bar Seal		

	No. of Feet
Tear Seal	
Bar Seal	
Bar Seal	

Code	Ga.	PCS	Cutting Specs		Code	Ga.	Pcs.	Cutting Specs	
			Size	Out				Size	Out
Cover Mat.	12 3/8	15	1		Lining Mat.	12 3/8	15	1	
Cover Mat.					Lining Mat.				
Vert. Pckt.					Horz. Pckt.	5 3/8 X 13 5/8			
Vert. Pckt.					Horz. Pckt.	5 3/8 X 29 3/8			
Pocket					Pocket				
Label Holder					Card Holder				
Material					Material				
Material					Material				
Material					Material				
F.C. Board	11 13/32	120	1		B.C. Board				
B.C. Board	11 13/32	120	1		B.B. Board	11 13/32 X 12 9/32	120	1	
Center Board					Board				
Board					Strip				
Cover Pad					Strip				
					B.B. Pad				

Product Code

Style Case **VRB**

Sheet Size **11 x 11 1/2** Cap. **1 1/2** Die No. **4216**

Order No. **962637** Plate

Customer **CLASSIC FORMAL WEAR**

Metal
Total Vinyl
Quantity
Date
Type Corners
Radius
Completed

	Gauge	Thick
Tear Seal		
Bar Seal		
Bar Seal		

	No. of Feet
Tear Seal	
Bar Seal	
Bar Seal	

PER SAMPLE

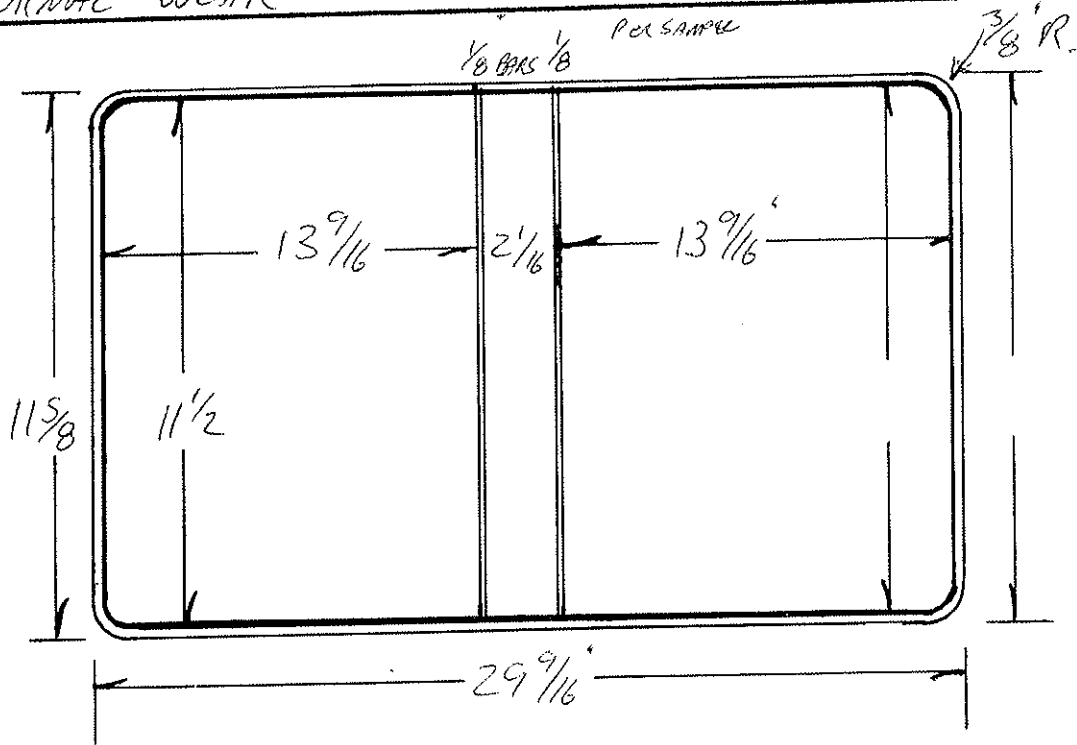

Code		Ga.	# PCS	Size	Out	Cutting Specs	Code		Ga.	# Pcs.	Size	Out	Cutting Specs
Cover Mat.	12 1/4 X 30 1/2	15	1				Lining Mat.	12 1/4 X 30 1/2	15	1			
Cover Mat.	X						Lining Mat.	X					
Vert. Pckt.	X						Horz. Pckt.	5 3/8 X 14 1/16					
Vert. Pckt.	X						Horz. Pckt.	5 3/8 X 30 1/2					
Pocket	12 1/4 X 30 1/2	8	1				Pocket	X					
Label Holder	X						Card Holder	X					
Material	X						Material	X					
Material	X						Material	X					
Material	X						Material	X					
F.C. Board	11 13/32 X 13 15/32	120	1				B.C. Board	X					
B.G. Board	11 13/32 X 13 15/32	120	1				B.B. Board	11 13/32 X 1 31/32	120	1			
Center Board	X						Board	X					
Board	X						Strip	X					
Cover Pad	X						Strip	X					
							B.B. Pad	X					

Product Code

Stock

Style Case

VRB

Sheet Size 11 X 17 1/2 Cap. 1/2

Die No. 4217

Order No. 962681

Plate

Customer GRAPHIC DATA KITS INTL

Metal
Total Vinyl
Quantity 100
Date 5-23-89
Type Corners RND.
Radius 3/8"
Completed

	Gauge	Thick
Tear Seal	016"	7/32
Bar Seal		5/32"
Bar Seal		

	No. of Feet
Tear Seal	
Bar Seal	
Bar Seal	

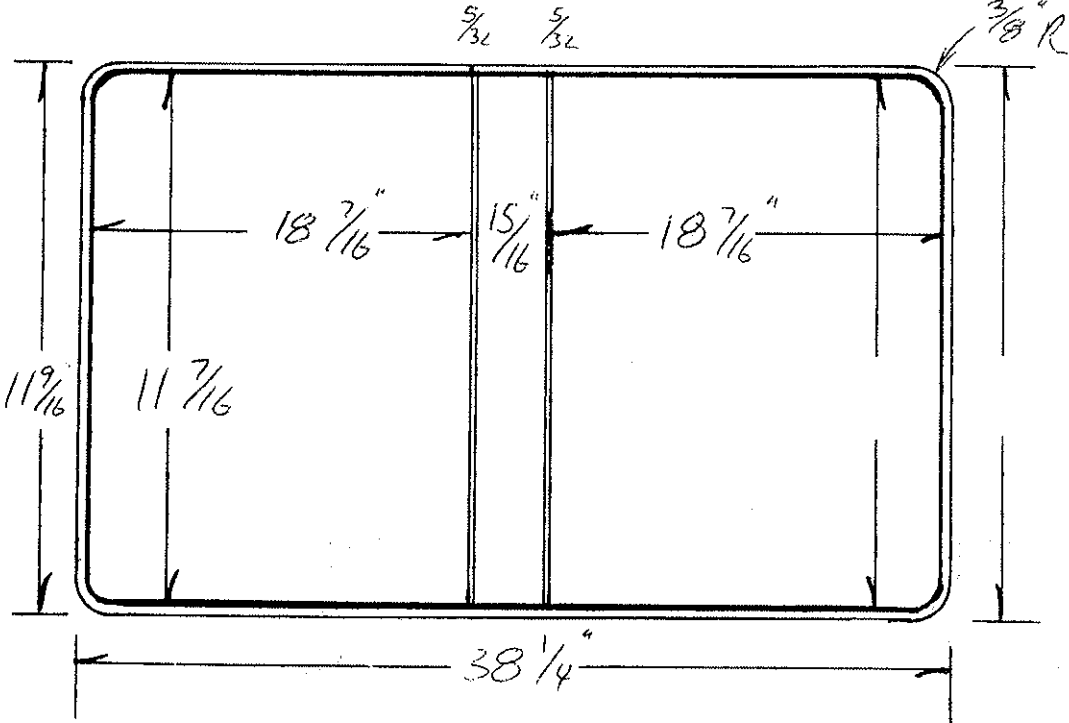

Code		Cutting Specs		Code		Cutting Specs			
		Ga.	Pcs	Size	Out	Ga.	Pcs	Size	Out
Cover Mat.	12 1/4" X 39"	15	1			Lining Mat.	12 1/4" X 39"	15	1
Cover Mat.	X					Lining Mat.	X		
Vert. Pckt.	X					Horz. Pckt.	5 3/8" X 39"		
Vert. Pckt.	X					Horz. Pckt.	5 3/8" X 19"		
Pocket	X					Pocket	X		
Label Holder	X					Card Holder	X		
Material	X					Material	X		
Material	X					Material	X		
Material	X					Material	X		
F.C. Board	120PT 11 1/32" X 18 3/8"	120	1			B.C. Board	X		
B.G. Board	120PT 11 1/32" X 18 3/8"	120	1			B.B. Board	120PT 11 1/32" X 27/32"	120	1
Center Board	100PT 11 3/8" X 18 3/8"		1			Board BK	100PT 11 3/8" X 7/8"	100	1
Board FC	100PT 11 3/8" X 18 3/8"		1			Strip	X		
Cover Pad	X					Strip	X		
						B.B. Pad	X		

Product Code

OLD # 971

Style Case

VRB

Sheet Size 11 x 17 1/2 Cap. 1 1/2

Die No. 4224

Order No. —

Plate

Customer HALL METAL

- Overized -

Metal
Total Vinyl
Quantity
Date 6-8-89
Type Corners RND
Radius 3/8"
Completed 6-6-89

1/8 1/8

Gauge	Thick
Tear Seal 016	7/32
Bar Seal #253	1/8"
Bar Seal	

No. of Feet	
Tear Seal	
Bar Seal	
Bar Seal	

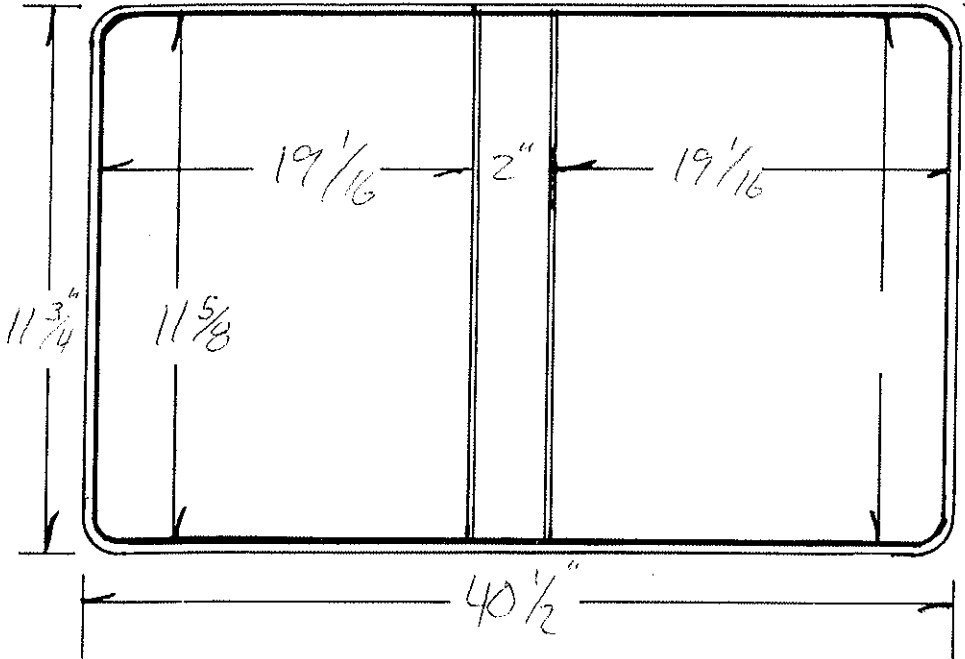

Die Re-MADE

Code	Ga.	# PCS	Cutting Specs		Code	Ga.	# Pcs.	Cutting Specs				
			Size	Out				Size	Out			
Cover Mat.			12 1/2 X	41 1/2	15	1	Lining Mat.		12 1/2 X	41 1/2	15	1
Cover Mat			X				Lining Mat.		X			
Vert. Pckt.			X				Horz. Pckt.		5 3/8 X	19 9/16		
Vert. Pckt.			X				Horz. Pckt.		5 3/8 X	21 1/2		
Pocket			X				Pocket		X			
Label Holder			X				Card Holder		X			
Material			X				Material		X			
Material			X				Material		X			
Material			X				Material		X			
F.C. Board			11 1/32 X	18 3/32	120	1	B.C. Board		X			
B.C. Board			11 1/32 X	18 3/32	120	1	B.B. Board		11 1/32 X	1 29/32	120	1
Center Board			X				Board	B.D	11 9/16 X	1 29/32		
Board	Fc+Bl		11 9/16 X	19	100	2	Strip		X			
Cover Pad			X				Strip		X			
							B.B. Pad		X			



Product Code

OLD # 707 Stock

Style Case

VRB WOC-STA. U  
DLVBO

Sheet Size 11 x 17 1/2 Cap. 1

Die No. 4308

Order No. STOCK

Plate

Customer

STOCK

Metal
Total Vinyl
Quantity
Date 10-23-89
Type Corners
Radius 3/8"
Completed 10-23-89 KST

Gauge	Thick
Tear Seal	
Bar Seal	
Bar Seal	

No. of Feet
Tear Seal
Bar Seal
Bar Seal

SIZE BY: R.P.

CHECK BY:

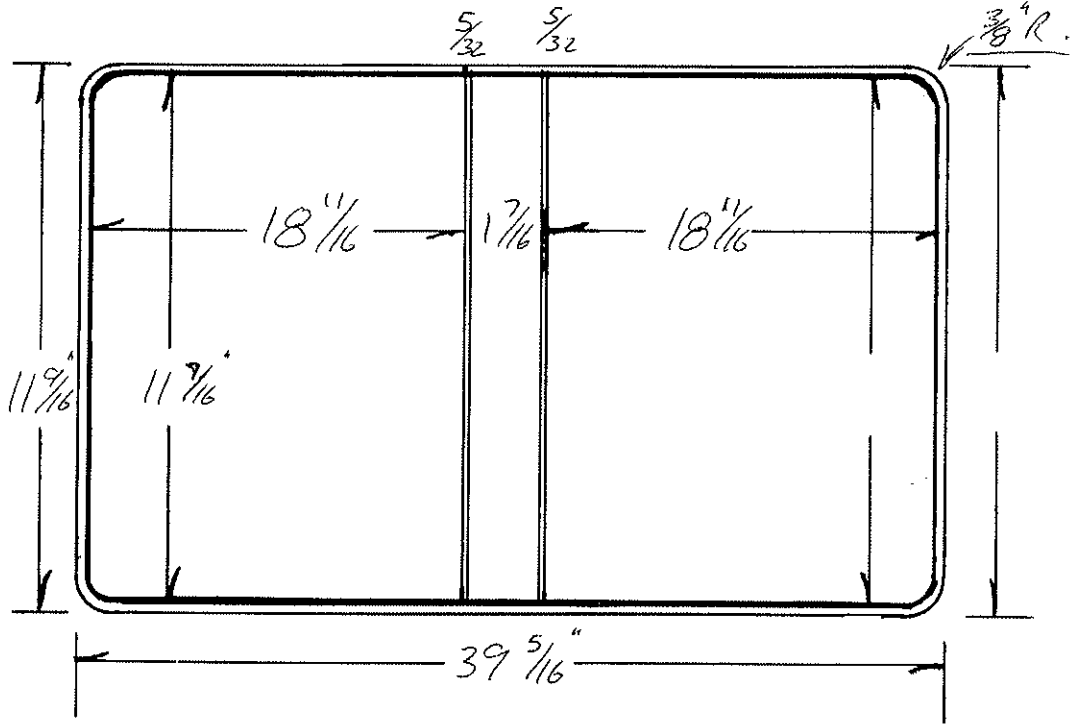

Code	Ga.	#	Cutting Specs		Code	Ga.	#	Cutting Specs	
			Size	Out				Size	Out
Cover Mat.			12 1/4 X	40 1/4	Lining Mat.			12 1/4 X	40 1/4
Cover Mat.			X		Lining Mat.			X	
Vert. Pckt.			X		Horz. Pckt. 1 side			5 3/8 X	19 1/4
Vert. Pckt.			X		Horz. Pckt.			5 3/8 X	40 1/4
Pocket	COL		11 11/16 X	40 1/4	Pocket			X	
Label Holder			X		Card Holder			X	
Material			X		Material			X	
Material			X		Material			X	
Material			X		Material			X	
F.C. Board			11 1/32 X	18 19/32	B.C. Board			X	
B.G. Board			11 1/32 X	18 19/32	B.B. Board			11 1/32 X	1 1/32
Center Board			11 3/8 X	18 5/8	Board			X	
Board			11 3/8 X	1 1/32	Strip			X	
Cover Pad			X		Strip			X	
					B.B. Pad			X	

OLV # 3130

Product Code

Style Case

VRB.

Sheet Size

11 x 14 1/2 Cap. 1/2

Die No. 4333

Order No.

964073

Plate

Customer

DILLON FURNITURE

Metal
Total Vinyl
Quantity 500
Date 11-28-89
Type Corners
Radius 3/8
Completed 11-28-89

Gauge	Thick
Tear Seal .016	1/16"
Bar Seal 4.178	3/16"
Bar Seal	

No. of Feet
Tear Seal
Bar Seal
Bar Seal

SIZES BY: B.P.  
CHECK BY: *(Signature)*

V: 11-29-89

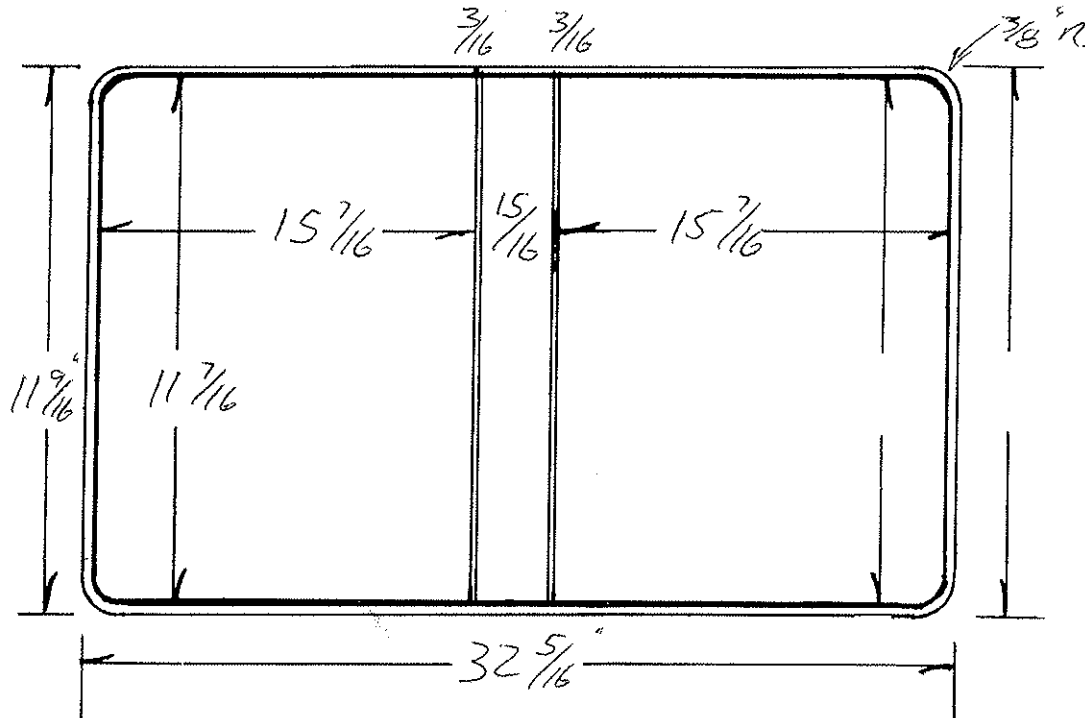

Code	Ga.	Pcs.	Cutting Specs		Code	Ga.	Pcs.	Cutting Specs	
			Size	Out				Size	Out
Cover Mat.			12 1/4 x 33 1/4	15 1	Lining Mat.			12 1/4 x 33 1/4	15 1
Cover Mat.			X		Lining Mat.			X	
Vert. Pckt.			X		Horz. Pckt.			5 3/8 x 16	
Vert. Pckt.			X		Horz. Pckt.			5 3/8 x 33 1/4	
Pocket			X		Pocket			X	
Label Holder			X		Card Holder			X	
Material			X		Material			X	
Material			X		Material			X	
Material			X		Material			X	
F.C. Board			11 1/32 x 15 1/32	100 1	B.C. Board			X	
B.C. Board			11 1/32 x 15 1/32	100 1	B.B. Board			11 1/32 x 27/32	100 1
Center Board			X		Board			X	
Board			X		Strip			X	
Cover Pad			X		Strip			X	
					B.B. Pad			X	

Product Code

Style Case *VRB W/METAL ON B.C.*

Sheet Size *11* X *14 1/2* Cap. *2*

Die No. *4369*

Order No. *964631*

Plate

*MR. FORMAL*

Customer

Metal
Total Vinyl
Quantity <i>300</i>
Date <i>1-23-90</i>
Type Corners
Radius <i>3/8"</i>
Completed

	Gauge	Thick
Tear Seal	<i>#114</i>	<i>1/16"</i>
Bar Seal	<i>#254</i>	<i>7/32"</i>
Bar Seal		

	No. of Feet
Tear Seal	
Bar Seal	
Bar Seal	

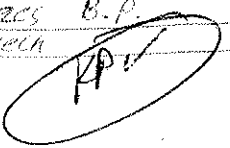
*SIZES B.P. CHECK*  

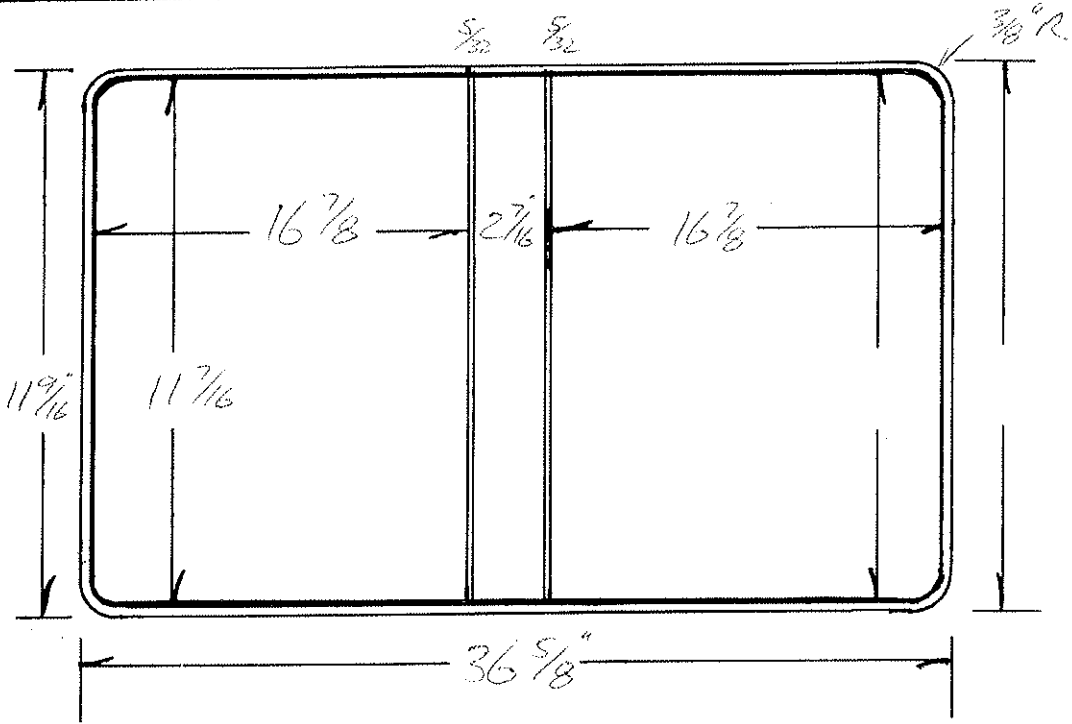

Code	Ga.	PCS	Cutting Specs		Code	Ga.	Pcs.	Cutting Specs	
			Size	Out				Size	Out
Cover Mat.		<i>12 1/4 X 37 1/2</i>	<i>15</i>	<i>1</i>	Lining Mat.		<i>12 1/4 X 37 1/2</i>	<i>15</i>	<i>1</i>
Cover Mat		X			Lining Mat.		X		
Vert. Pckt.		X			Horz. Pckt.		<i>5 3/8 X 17 3/8</i>		
Vert. Pckt.		X			Horz. Pckt.		<i>5 3/8 X 37 1/2</i>		
Pocket		X			Pocket		X		
Label Hoker		X			Card Holder		X		
Material		X			Material		X		
Material		X			Material		X		
Material		X			Material		X		
F.C. Board		<i>11 1/32 X 16 25/32</i>	<i>120</i>	<i>1</i>	B.C. Board		X		
B.C. Board		<i>11 1/32 X 16 25/32</i>	<i>120</i>	<i>1</i>	B.B. Board		<i>11 1/32 X 2 1/32</i>	<i>120</i>	<i>1</i>
Center Board		X			Board		X		
Board		X			Strip		X		
Cover Pad		X			Strip		X		
					B.B. Pad		X		



OLD # 3527

VRB.

Product Code

Style Case

Sheet Size 11 X 14 1/2 Cap. 1

Die No. 4375

Order No. 964750

Plate

QUALEX, INC.

Customer

Metal
Total Vinyl
Quantity 200
Date 2-6-90
Type Corners
Radius
Completed 2-8-90

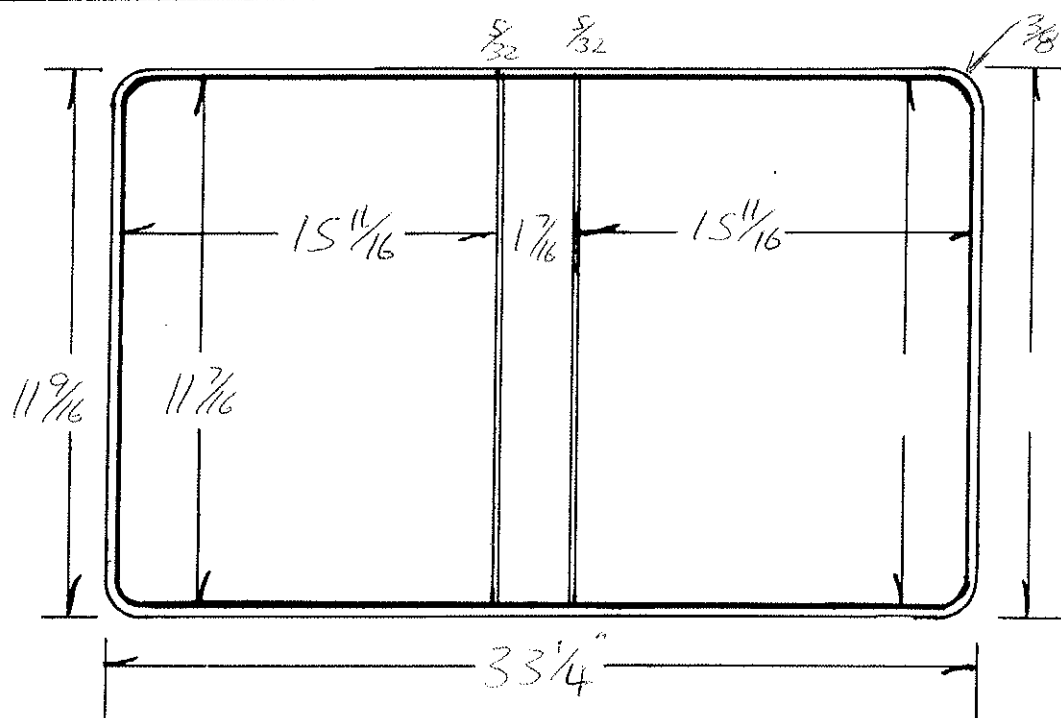

	Gauge	Thick
Tear Seal	.014	1/16
Bar Seal	#253	9/32
Bar Seal		

	No. of Feet
Tear Seal	
Bar Seal	
Bar Seal	

500 - B.P. 2-6-90

Handwritten initials/signature

LOC-L-6-4

Code	Ga.	# PCS	Cutting Specs		Code	Ga.	# Pcs.	Cutting Specs	
			Size	Out				Size	Out
Cover Mat.		12 1/4 X 34 1/4	15	1	Lining Mat.		12 1/4 X 34 1/4	15	1
Cover Mat		X			Lining Mat.		X		
Vert. Pckt.		X			Horz. Pckt.		5 3/8 X 16 3/16		
Vert. Pckt.		X			Horz. Pckt.		5 3/8 X 34 1/4		
Pocket		X			Pocket		X		
Label Holder		X			Card Holder		X		
Material		X			Material		X		
Material		X			Material		X		
Material		X			Material		X		
F.C. Board		11 1/32 X 15 19/32	100	1	B.C. Board		X		
B.G. Board		11 1/32 X 15 19/32	100	1	B.B. Board		11 1/32 X 1 1/32	100	1
Center Board		X			Board		X		
Board		X			Strip		X		
Cover Pad		X			Strip		X		
					B.B. Pad		X		



Stock

DIE #	4388-R	METAL	ROUND + ANGLE D	RADIUS	3/8
ORDER #		CUSTOMER		TEAR SEAL	.014
SHEET SIZE	11 X 17 1/2	STYLE CASE	VINYL RING BINDER	BAR SEAL	254
CAP.	3"	DUE DATE		COMPLETED	
LOCATION		QUANTITY		DATE	

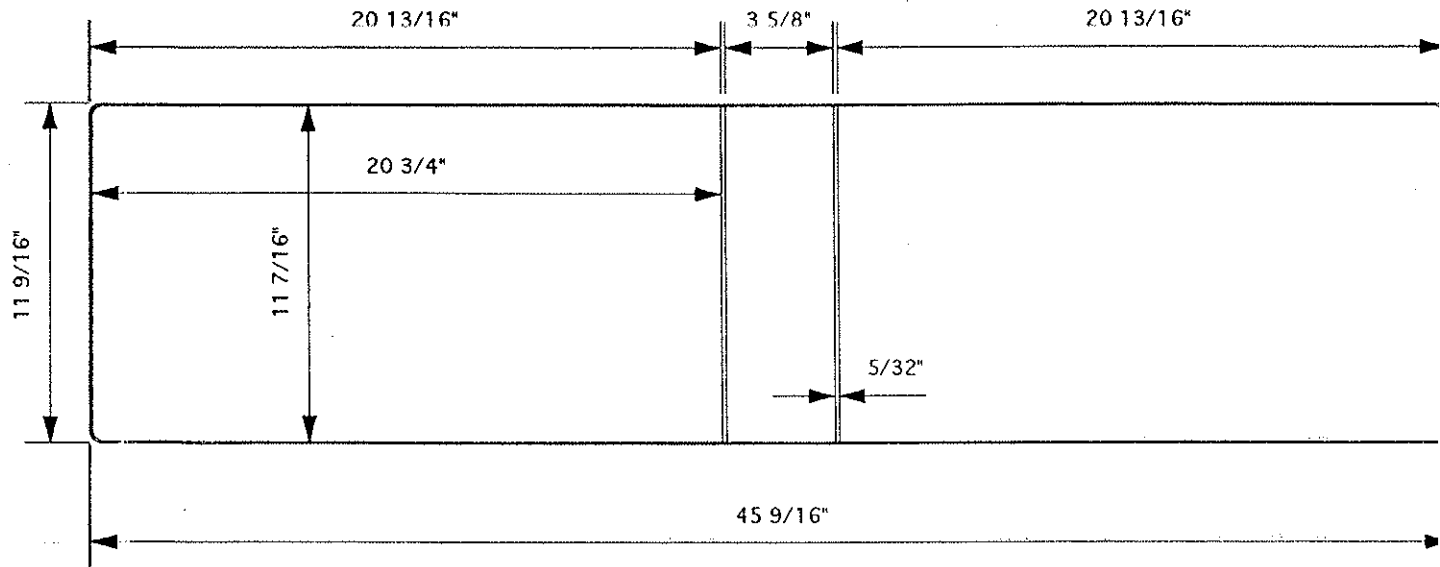

MATERIAL SPECS		GAUGE PCS.		MATERIAL SPECS		GAUGE	
COVER MAT.	12 1/4 X 46 1/2		1	LINING MAT.	12 1/4 X 46 1/2		
COVER MAT.				LINING MAT.			
CARD HOLDER				HORZ. PKT.	5 3/8 X 21 3/8		
COL	11 3/4 X 46 1/2		1	VERT. PKT.			
LABEL HOLDER				DIAG. PKT			
EX CDL BUSSER	11 3/4 X 25 5/8		1	REINF.			
BOARD SPECS		GAUGE PCS.		BOARD SPECS		GAUGE	
F.C. BOARD	11 11/32 X 20 21/32	120	1	F.C. BOARD			
B.B. BOARD	11 11/32 X 3 17/32	120	1	B.B. BOARD			
B.C. BOARD	11 11/32 X 20 21/32	120	1	B.C. BOARD			
B.U. STRIP				DIE CUT			
DIE CUT				DIE CUT			

Product Code

Style Case DATA RING - VRB

Sheet Size 11 x 10 Cap. 1 1/2 Die No. 4391 Order No. 964928 Plate

Customer

EAGLE LAKE RICE DRYER, INC.

Metal
Total Vinyl
Quantity
Date 3-7-90
Type Corners
Radius 3/16"
Completed

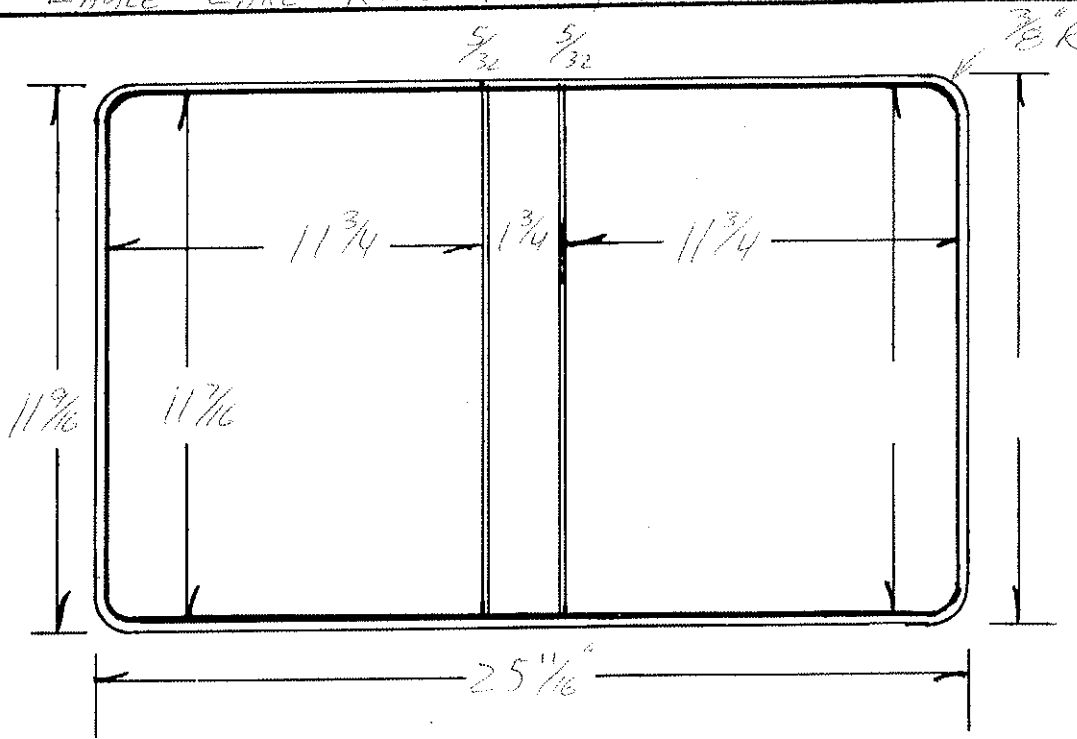

	Gauge	Thick
Tear Seal	204	1/16
Bar Seal	2254	5/32"
Bar Seal		

	No. of Feet
Tear Seal	
Bar Seal	
Bar Seal	

Size - B. Pace

Check - *(Signature)*

Code	Ga.	# PCS	Cutting Specs		Code	Ga.	# Pcs.	Cutting Specs	
			Size	Out				Size	Out
Cover Mat.		12 1/4 X 26 1/2	15	1	Lining Mat.		12 1/4 X 26 1/2	15	1
Cover Mat.		X			Lining Mat.		X		
Vert. Pckt.		X			Horz. Pckt.		5 3/8 X 12 1/4		
Vert. Pckt.		X			Horz. Pckt.		5 3/8 X 26 1/2		
Pocket		X			Pocket		X		
Label Holder		10 5/16 X 2 3/4	8	1	Card Holder		X		
Material		X			Material		X		
Material		X			Material		X		
Material *		X			Material		X		
F.C. Board		11 1/32 X 11 24/32	100	1	B.C. Board		X		
B.C. Board		11 1/32 X 11 24/32	100	1	B.B. Board		11 1/32 X 1 24/32	100	1
Center Board		X			Board		X		
Board		X			Strip		X		
Cover Pad		X			Strip		X		
					B.B. Pad		X		

Product Code

Style Case

VRB

Sheet Size 11 X 10

Cap. 1

Die No. 4407

Order No. 965199

Plate

Customer

EAGLE LAKE

Metal
Total Vinyl
Quantity 50
Date 4-11-90
Type Corners
Radius 3/8"
Completed

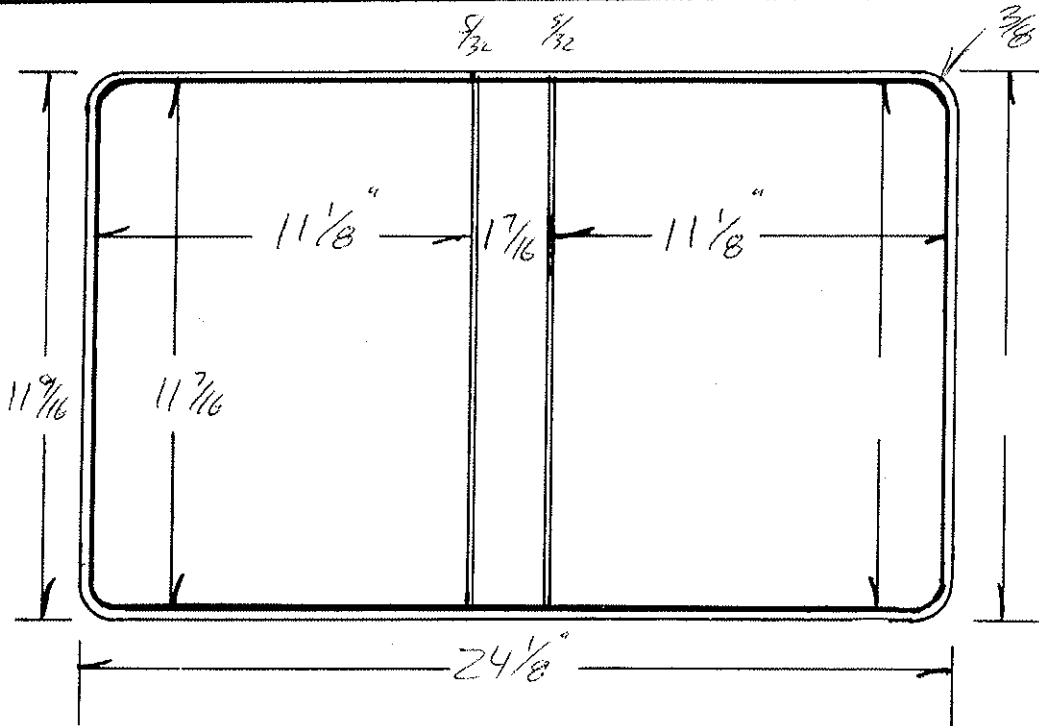

	Gauge	Thick
Tear Seal	.014	7/16
Bar Seal	#254	5/16
Bar Seal		

	No. of Feet
Tear Seal	
Bar Seal	
Bar Seal	

Size - B. Paper  
 Check - YPR

Code	Ga.	Pcs	Cutting Specs		Code	Ga.	Pcs	Cutting Specs	
			Size	Out				Size	Out
Cover Mat.		15	1		Lining Mat.		15	1	
Cover Mat.					Lining Mat.				
Vert. Pckt.					Horz. Pckt.				
Vert. Pckt.					Horz. Pckt.				
Pocket					Pocket				
Label Holder		8	1		Card Holder				
Material					Material				
Material					Material				
Material					Material				
F.C. Board		100	1		B.C. Board				
B.C. Board		100	1		B.B. Board				
Center Board					Board				
Board					Strip				
Cover Pad					Strip				
					B.B. Pad				

Product Code

Stock

Style Case

VRB

HDC-5

Sheet Size 11 X 17 1/2 Cap. Z

Die No 4826

Order No. 969559

Plate K-38

Customer

UTILITY CONTROL EQUIPMENT

8-6

Metal
Total Vinyl
Quantity 25
Date 7-16-91
Type Corners
Radius 3/8
Completed

	Gauge	Thick
Tear Seal	.014	1/6
Bar Seal	48.4	5/8
Bar Seal		

	No. of Feet
Tear Seal	
Bar Seal	
Bar Seal	

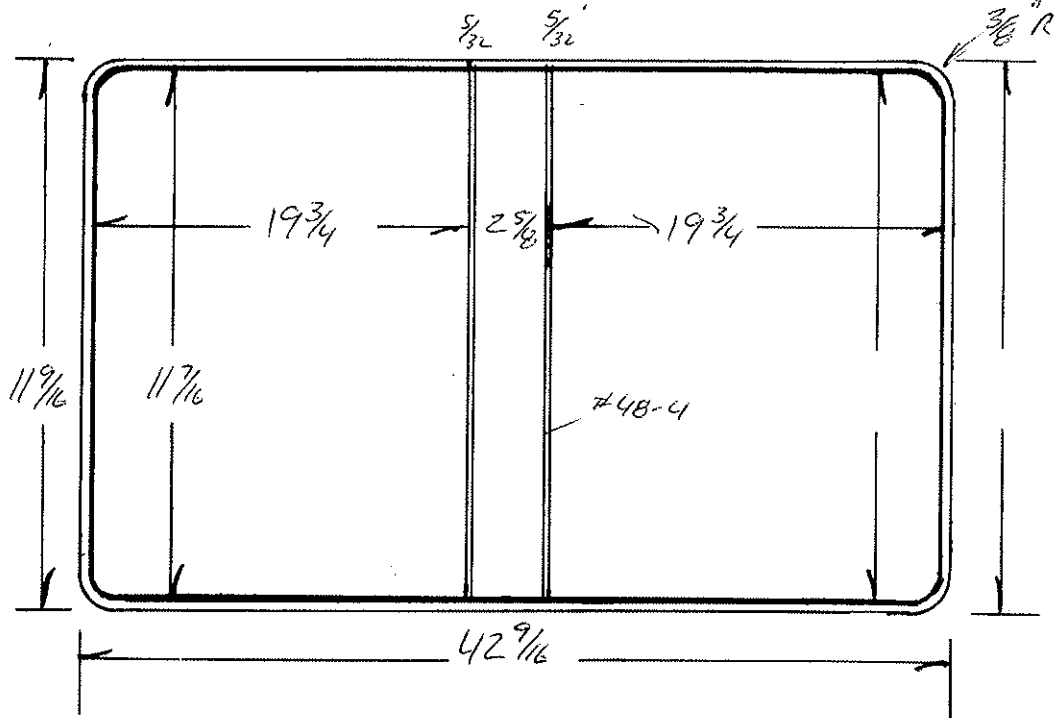

DWG - B. Spec  
CHECK

Code	Ga.	#	PCS	Cutting Specs		Code	Ga.	#	Pcs.	Cutting Specs	
				Size	Out					Size	Out
Cover Mat.			15	1		Lining Mat.			15	1	
Cover Mat.						Lining Mat.					
Vert. Pckt.						Horz. Pckt.					
Vert. Pckt.						Horz. Pckt.					
Pocket						Pocket					
Label Holder						Card Hlder					
Material						Material					
Material						Material					
Material						Material					
F.C. Board						B.C. Board					
B.G. Board						B.B. Board					
Center Board						Board					
Board						Strip					
Cover Pad						Strip					
						B.B. Pad					

Product Code

Stock

Style Case V1-D

Sheet Size 11 x 17 1/2 Cap. 1 1/2

Die No. 4873

Order No. 970037

Plate K-4-S

9-12

Customer

DIGITAL EQUIPMENT

Metal
Total Vinyl
Quantity <u>250</u>
Date <u>9-5-91</u>
Type Corners
Radius <u>3/8</u>
Completed

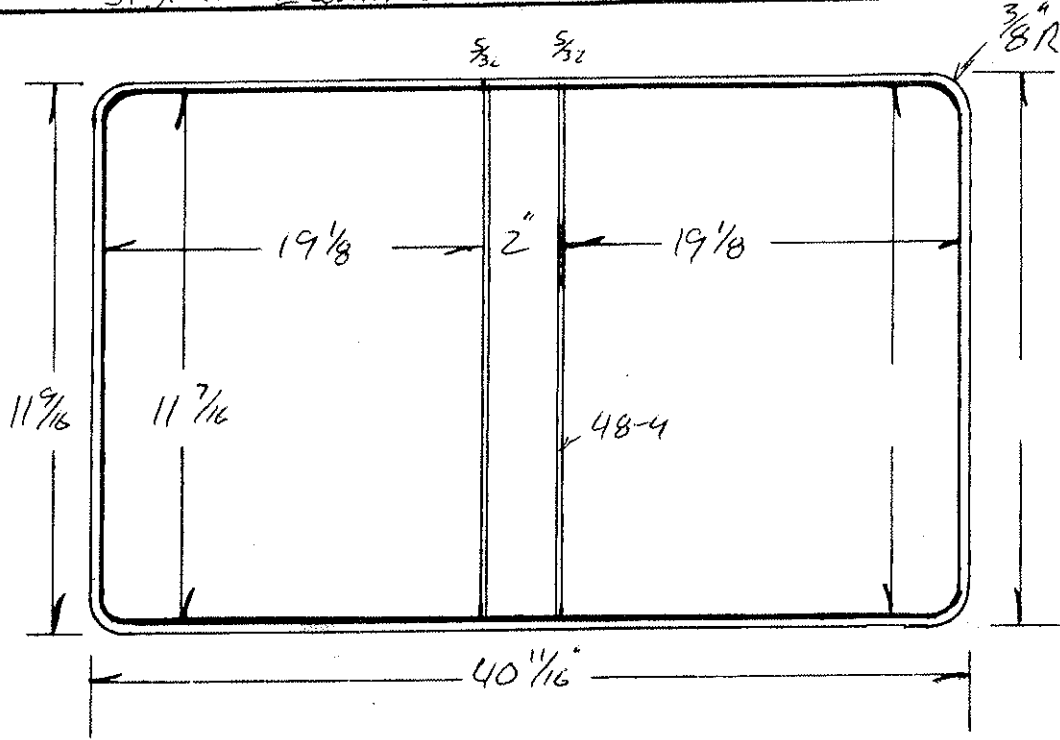

	Gauge	Thick
Tear Seal	<u>.014</u>	<u>1/16</u>
Bar Seal	<u>48-4</u>	<u>5/32</u>
Bar Seal		

	No. of Feet
Tear Seal	
Bar Seal	
Bar Seal	

Dwg. B. Price  
 Check KPV

Code	Cutting Specs				Code	Cutting Specs					
	Ga.	Pcs.	Size	Out		Ga.	Pcs.	Size	Out		
Cover Mat.			<u>12 1/4 X 4 1/4</u>	<u>15</u>	<u>1</u>	Lining Mat.			<u>12 1/4 X 4 1/4</u>	<u>15</u>	<u>1</u>
Cover Mat			X			Lining Mat.			X		
Vert. Pckt.			X			Horz. Pckt.			<u>5 3/8 X 4 1/4</u>		
Vert. Pckt.			X			Horz. Pckt. 1-sided			<u>5 3/8 X 1 9/8</u>		
Pocket			X			Pocket	Full Col		<u>11 1/16 X 4 1/4</u>		
Label Holder			X			Card Hlder	ES Col		<u>11 1/16 X 2 3/8</u>		
Material			X			Material			X		
Material			X			Material			X		
Material			X			Material			X		
F.C. Board			<u>11 1/32 X 1 9/32</u>	<u>120</u>	<u>1</u>	B.C. Board			X		
B.C. Board			<u>11 1/32 X 1 9/32</u>	<u>120</u>	<u>1</u>	B.B. Board			<u>11 1/32 X 1 29/32</u>	<u>120</u>	<u>1</u>
Center Board			<u>11 3/8 X 1 9 1/16</u>	<u>100</u>	<u>2</u>	Board			<u>11 3/8 X 1 29/32</u>	<u>100</u>	<u>1</u>
Board			X			Strip			X		
Cover Pad			X			Strip			X		
						B.B. Pad			X		

Product Code Use 00 2" D - Imported

Old

Style Case URB 2 1/2 NOG

Sheet Size 11 x 17 1/2 Cap. 2 1/2 Die No. 4874

Order No. 970034 2 1/2 Plate K-4-6

2 1/2 Angle D

DIGITAL EQUIPMENT

Customer	
Metal	
Total Vinyl	
Quantity	250
Date	9-5-81
Type Corners	3/8
Radius	
Completed	

	Gauge	Thick
Tear Seal	014	1/2
Bar Seal	48-4	5/32
Bar Seal		

	No. of Feet
Tear Seal	
Bar Seal	
Bar Seal	

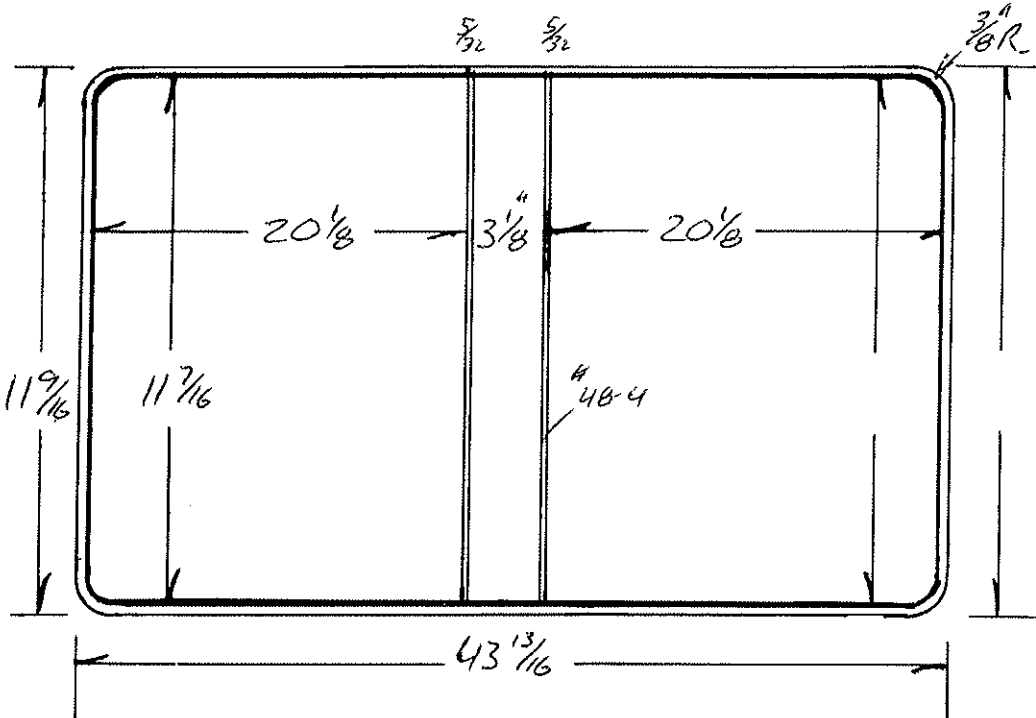

Dwg. B. Page  
 Chew *KPV*

Code	Ga.	PCS	Cutting Specs		Code	Ga.	Pcs.	Cutting Specs			
			Size	Out				Size	Out		
Cover Mat.	12 1/4	X	44 7/8	15	1	Lining Mat.	12 1/4	X	44 7/8	15	1
Cover Mat.			X			Lining Mat.			X		
Vert. Pckt.			X			Horz. Pckt.			X		
Vert. Pckt.			X			Horz. Pckt.			X		
Pocket			X			Pocket			X		
Label Holder			X			Card Holder			X		
Material			X			Material			X		
Material			X			Material			X		
Material			X			Material			X		
F.C. Board	11 1/32	X	20 1/32	120	1	B.C. Board			X		
B.C. Board	11 1/32	X	20 1/32	120	1	B.B. Board	11 1/32	X	3 1/32	120	1
Center Board	11 3/8	X	20 1/16	100	2	Board			X		
Board	11 3/8	X	3 1/32	100	1	Strip			X		
Cover Pad			X			Strip			X		
						B.B. Pad			X		



Product Code

Style Case *VRB*

Sheet Size *11 x 5 1/2*

Cap. *3/4*

Die No. *4881*

Order No. *970126*

Plate *C-19-2*

Customer

*CENTRAL CAROLINA BANK*

*10-8*

Metal
Total Vinyl
Quantity <i>50</i>
Date <i>9-19-91</i>
Type Corners
Radius <i>3/8</i>
Completed

	Gauge	Thick
Tear Seal	<i>.014</i>	<i>1/16</i>
Bar Seal	<i>2.53</i>	<i>1/8 PLAIN</i>
Bar Seal		

	No. of Feet
Tear Seal	
Bar Seal	
Bar Seal	

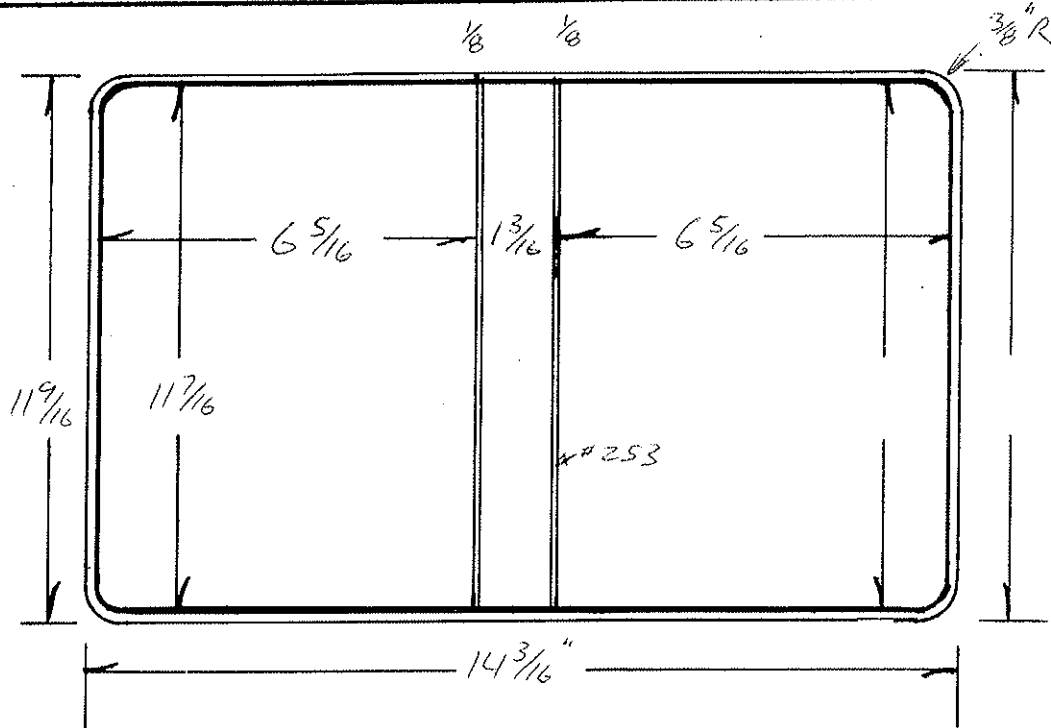

*DWG - B. Pace*  
*CHECK* *KPV*

*PER SAMPLE without STRAP*

		Cutting Specs						Cutting Specs			
Code		Ga.	# PCS	Size	# Out	Code		Ga.	# Pcs.	Size	# Out
Cover Mat.	<i>12 1/4 X 15"</i>	<i>14</i>	<i>1</i>			Lining Mat.	<i>12 1/4 X 15"</i>	<i>14</i>	<i>1</i>		
Cover Mat	X					Lining Mat.	X				
Vert. Pckt.	X					Horz. Pckt.	X				
Vert. Pckt.	X					Horz. Pckt.	X				
Pocket	X					Pocket	X				
Label Holder	X					Card Holder	X				
Material	X					Material	X				
Material	X					Material	X				
Material	X					Material	X				
F.C. Board	<i>11 3/8 X 6 1/4</i>	<i>100</i>	<i>1</i>			B.C. Board	X				
B.C. Board	<i>11 3/8 X 6 1/4</i>	<i>100</i>	<i>1</i>			B.B. Board	<i>11 3/8 X 1 3/32</i>	<i>100</i>	<i>1</i>		
Center Board	X					Board	X				
Board	X					Strip	X				
Cover Pad	X					Strip	X				
						B.B. Pad	X				

Product Code

Style Case *VRB - 3" STOCK A.D. (11-3-2 1/2)*

Sheet Size *11 X 14 1/2 Cap. \*3 AD* Die No. *4918*

Order No. *61977* Plate *K-5-2*

Customer	<i>NSC / UNLIMITED GRAPHICS</i>
Metal	
Total Vinyl	
Quantity	<i>20</i>
Date	<i>11-12-91</i>
Type Corners	
Radius	
Completed	

	Gauge	Thick
Tear Seal	<i>.014</i>	<i>1/16</i>
Bar Seal	<i>48-4</i>	<i>5/32</i>
Bar Seal		

	No. of Feet
Tear Seal	
Bar Seal	
Bar Seal	

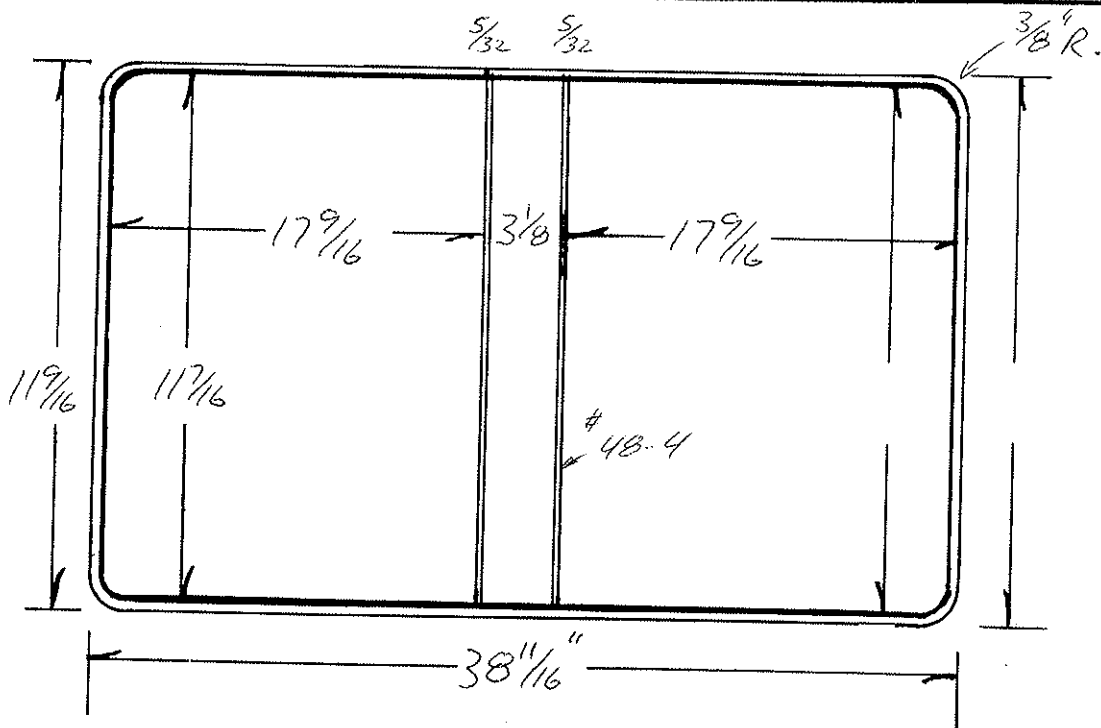

*Dwg. - Blace*  
*Check - (Signature)*

*\* 11-3-2 1/2 ADVANTAGE A.O.*

Code		Cutting Specs				Code		Cutting Specs			
		Ga.	PCS	Size	Out			Ga.	Pcs.	Size	Out
Cover Mat.	<i>12 1/4 X 39 3/4</i>		<i>1</i>			Lining Mat.	<i>12 1/4 X 39 3/4</i>		<i>1</i>		
Cover Mat	X					Lining Mat.	X				
Vert. Pckt.	X					Horz. Pckt.	X				
Vert. Pckt.	X					Horz. Pckt.	X				
Pocket	X					Pocket	X				
Label Holder	X					Card Holder	X				
Material	X					Material	X				
Material	X					Material	X				
Material	<i>F.C.</i> X					Material	X				
F.C. Board	<i>Added 11 11/32 X 17 15/32</i>	<i>120</i>	<i>1</i>			B.C. Board	X				
B.C. Board	<i>11 11/32 X 17 15/32</i>	<i>120</i>	<i>1</i>			B.B. Board	<i>11 11/32 X 3 1/32</i>	<i>120</i>	<i>1</i>		
Center Board	X					Board	X				
Board	X					Strip	X				
Cover Pad	X					Strip	X				
						B.B. Pad	X				

Product Code

Style Case VRB

11-3-2-A.O.(8)

Sheet Size 11 x 12 1/4 Cap. 2" A.O.

Die No. 4936

Order No. 970801

Plate D-2-

Customer

C. J. OFFICE PRODUCTS

12-36

Metal	11-3-2-A.O. ST04
Total Vinyl	
Quantity	100
Date	12-11-91
Type Corners	
Radius	2/8
Completed	

	Gauge	Thick
Tear Seal	.014	1/16
Bar Seal	48-41	5/32"
Bar Seal		

	No. of Feet
Tear Seal	
Bar Seal	
Bar Seal	

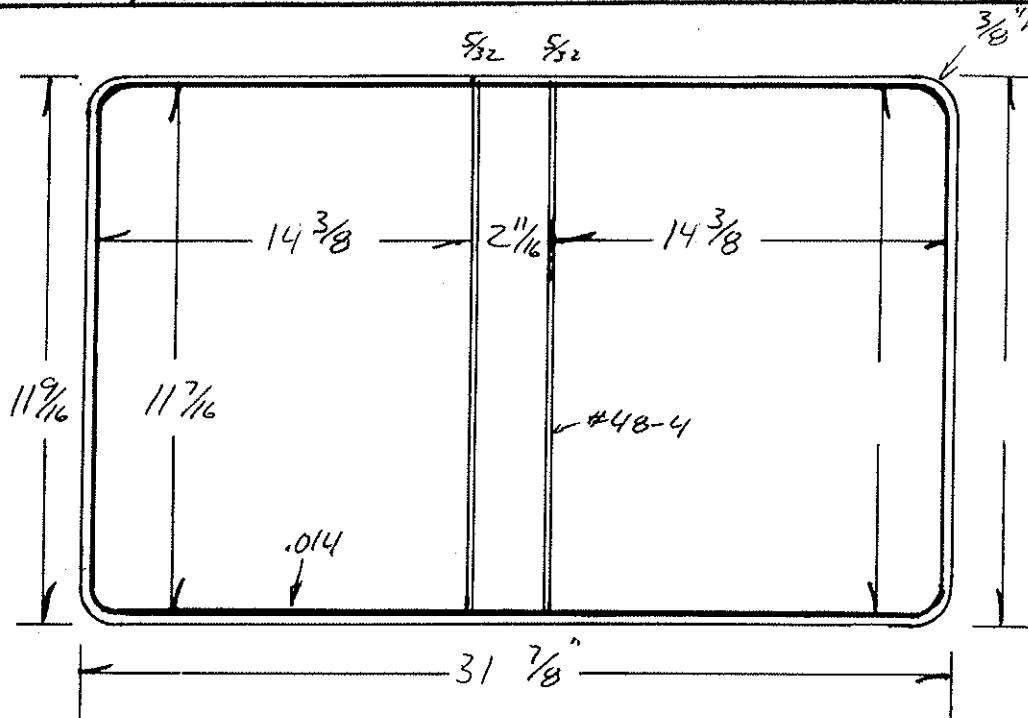

Dwy - B. Hall  
 Check - *(Signature)*

Code	Ga.	#	Cutting Specs		Code	Ga.	#	Cutting Specs	
			Size	Out				Size	Out
Cover Mat.			12 1/4		Lining Mat.			12 1/4	
			X					X	
Vert. Pckt.			X		Horz. Pckt.			X	
Vert. Pckt.			X		Horz. Pckt.			X	
Pocket			X		Pocket			X	
Label Holder			X		Card Holder			X	
Material			11 1/16		Material			X	
			X		Material			X	
Material			X		Material			X	
F.C. Board			11 1/32		B.C. Board			X	
			X					X	
B.C. Board			11 1/32		B.B. Board			11 1/32	
			X					X	
Center Board			X		Board			X	
Board			X		Strip			X	
Cover Pad			X		Strip			X	
					B.B. Pad			X	



Product Code

Style Case **VRB**

Sheet Size **11** x **9 5/8** Cap. **2 A.D.** Die No. **4999-1** Order No. **971441** Plate **D-4-8**

**C.J. OFFICE PRODUCTS**

3-10

Customer

Metal
Total Vinyl
Quantity <b>100</b>
Date <b>2-26-92</b>
Type Corners
Radius <b>3/8</b>
Completed

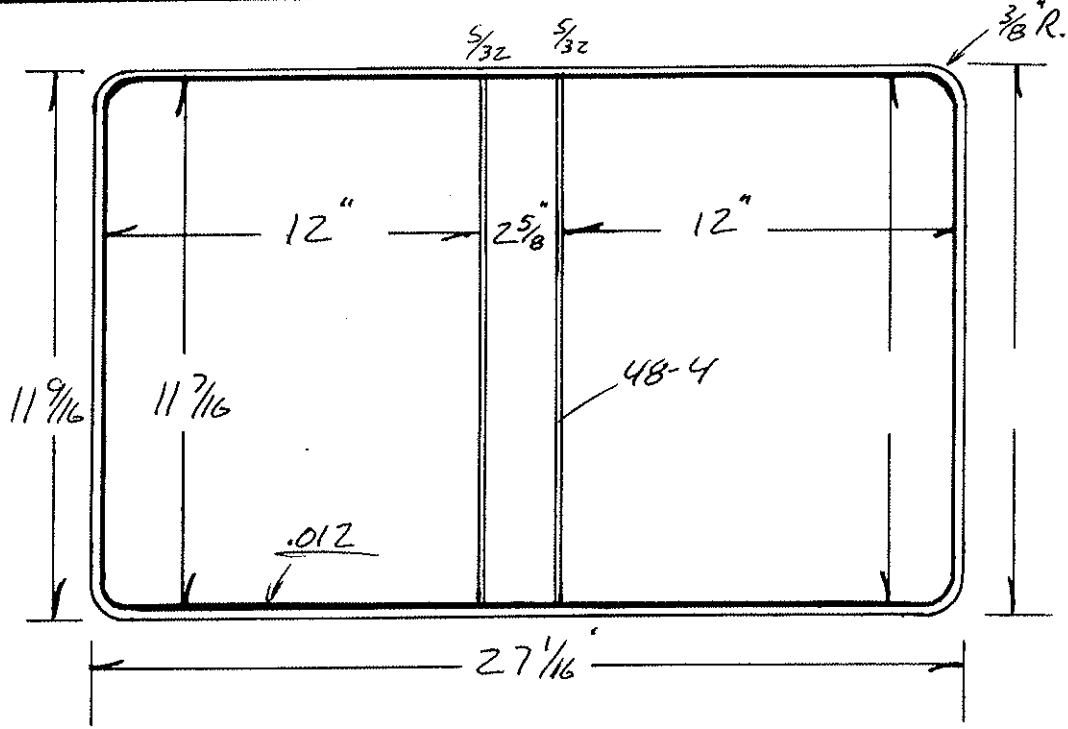

	Gauge	Thick
Tear Seal	.012	1/16
Bar Seal	48-4	5/32
Bar Seal		

	No. of Feet
Tear Seal	
Bar Seal	
Bar Seal	

Dwy B. Pace  
CHECK. *[Signature]*

Code	Ga.	PCS	Cutting Specs		Code	Ga.	Pcs.	Cutting Specs			
			Size	Out				Size	Out		
Cover Mat.			12 1/4	X 27 7/8	12	1	Lining Mat.		12 1/4 X 27 7/8	12	1
Cover Mat.				X			Lining Mat.			X	
Vert. Pckt.				X			Horz. Pckt.			X	
Vert. Pckt.				X			Horz. Pckt.			X	
Pocket				X			Pocket			X	
Label Holder				X			Card Holder			X	
Material	<i>Full COL.</i>		11 11/16	X 27 7/8	8	1	Material			X	
Material				X			Material			X	
Material				X			Material			X	
F.C. Board			11 11/32	X 11 29/32	120	1	B.C. Board			X	
B.G. Board			11 11/32	X 11 29/32	120	1	B.B. Board		11 11/32 X 27 17/32	120	1
Center Board			11 3/8	X 11 15/16		2	Board			X	
Board			11 3/8	X 27 17/32		1	Strip			X	
Cover Pad				X			Strip			X	
							B.B. Pad			X	

Product Code

Style Case VRB

Sheet Size 11 x 7 1/2

Cap. 3/4

Die No. 5012

Order No. 971540

Plate D-5-3

Customer EMBASSY SUITES HOTEL

3-16

Customer

Metal	
Total Vinyl	
Quantity	300
Date	3-9-92
Type Corners	
Radius	3/8
Completed	

	Gauge	Thick
Tear Seal	.014	1/16
Bar Seal	448-4	5/32"
Bar Seal		

	No. of Feet
Tear Seal	
Bar Seal	
Bar Seal	

Dwg B.Pae  
CHECK KPV

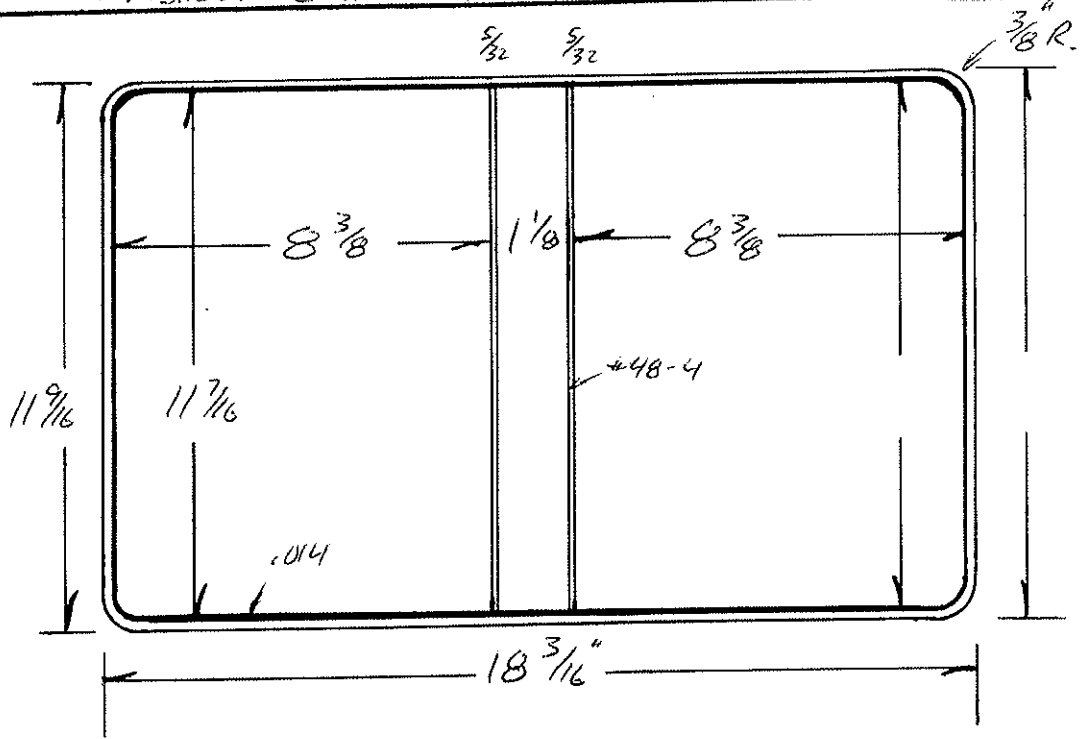

Code		Code	Cutting Specs		Code		Cutting Specs	
Code	Size	Code	Ga.	# PCS	Code	Size	Ga.	# PCS
Cover Mat.	12 1/4 x 19"	Lining Mat.		1	Lining Mat.	12 1/4 x 19"		1
Cover Mat Padded	12 9/16 x 19 1/4	Lining Mat.			Lining Mat.	X		
Vert. Pckt.	X	Horz. Pckt.			Horz. Pckt.	X		
Vert. Pckt.	X	Horz. Pckt.			Horz. Pckt.	X		
Pocket	X	Pocket <small>DIA9 CUT DIA9.</small>			Pocket <small>DIA9 CUT DIA9.</small>	9 x 9	14	1/2
Label Holder	X	Card Hlder			Card Hlder	X		
Material	X	Material			Material	X		
Material	X	Material			Material	X		
Material	X	Material			Material	X		
F.C. Board	11 3/8 x 8 5/16	B.C. Board		100	B.C. Board	X		
B.C. Board	11 3/8 x 8 5/16	B.B. Board		100	B.B. Board	11 3/8 x 1 1/32	100	1
Center Board	1 X	Board			Board	X		
Board	Cutting Die 5012	Strip			Strip	X		
<del>Padded Sizes</del>	<del>12 3/8 x 18 1/8</del>	Strip			Strip	X		
<del>Cover Pad</del>	<del>(Makes 2)</del>	B.B. Pad			B.B. Pad	X		
	12 3/8 x 25 13/16			100				
Cutting Die Panels & BL for Padded Bd.								



Product Code

OLD #1118

Style Case VRB

Sheet Size 11 x 12 1/2 Cap. 1

Die No. 5058

Order No. 972251

Plate D-7-4

VOICE TENNESSEE

S-29

Customer

Metal
Total Vinyl
Quantity 250
Date 5-12-92
Type Corners
Radius 3/8"
Completed

	Gauge	Thick
Tear Seal	1814	1/16
Bar Seal	254	5/32"
Bar Seal		

	No. of Feet
Tear Seal	
Bar Seal	
Bar Seal	

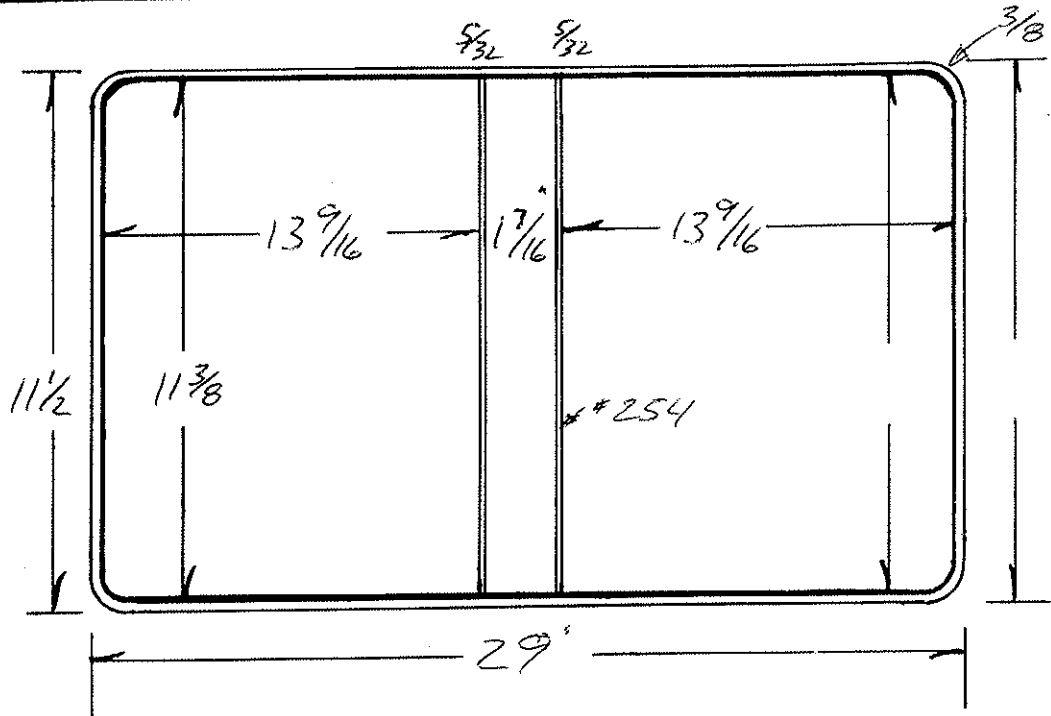

Dwgs. B. Price  
CHECK.

Code	Ga.	PCS	Cutting Specs		Code	Ga.	Pcs.	Cutting Specs	
			Size	Out				Size	Out
Cover Mat.		12 1/4 x 29 3/4	15	1	Lining Mat.		12 1/4 x 29 3/4	15	1
Cover Mat.		X			Lining Mat.		X		
Vert. Pckt.		X			Horz. Pckt.		X		
Vert. Pckt.		X			Horz. Pckt.		5 3/8 x 29 3/4	15	1
Pocket		X			Pocket		X		
Label Holder		X			Card Holder		X		
Material		X			Material		X		
Material		X			Material		X		
Material		X			Material		X		
F.C. Board		11 5/16 x 13 1/2	100	1	B.C. Board		X		
B.C. Board		11 5/16 x 13 1/2	100	1	B.B. Board		11 5/16 x 1 1/32	100	1
Center Board		X			Board		X		
Board		X			Strip		X		
Cover Pad		X			Strip		X		
					B.B. Pad		X		



Product Code

Style Case

VAB

Sheet Size 11 x 10 1/2 Cap. 1 1/2 Die No. 5141

Order No. 972632

Plate 8-17

Customer

Johnson Printing

D 10

Metal
Total Vinyl
Quantity 200
Date
Type Corners
Radius 3/8
Completed

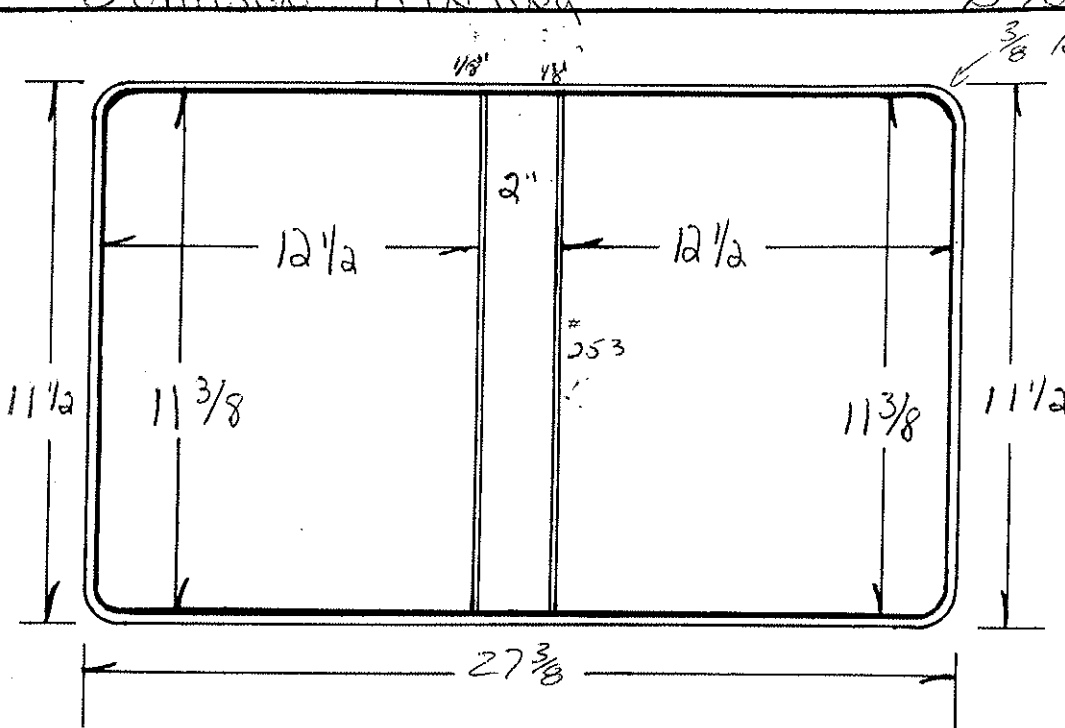

	Gauge	Thick
Tear Seal	.014	1/16
Bar Seal		
Bar Seal	.253	1/8

	No. of Feet
Tear Seal	
Bar Seal	
Bar Seal	

Dwg. Hired  
CHECK B. Pace

Code		Cutting Specs				Code		Cutting Specs					
		Ga.	#	PCS	Size	Out			Ga.	#	PCS	Size	Out
Cover Mat.	12 1/4 x 28 1/4	.014	1	240			Lining Mat.	12 1/4 x 28 1/4	14	1			
Cover Mat.	X						Lining Mat.	X					
Vert. Pckt.	X						Horz. Pckt.	X					
Vert. Pckt.	X						Horz. Pckt.	X					
Pocket	X						Pocket	X					
Label Holder	4 x 2 5/16	.008			Polished		Card Holder	X					
Material	X						Material	X					
Material	X						Material	X					
Material	X						Material	X					
F.C. Board	11 5/16 x 12 7/16	100	1				F.C. Board	11 7/32 x 12 13/32	120				
B.C. Board	11 5/16 x 12 7/16	100	1				B.C. Board	11 9/32 x 12 13/32	120				
Center Board	11 5/16 x 1 29/32	100	1				B.B. Board	11 7/32 x 1 29/32	120				
Board	X						Strip	X					
Cover Pad	X						Strip	X					
							B.B. Pad	X					

Flab Die # 5776

DIE #	5293	STYLE CASE	VRR	LOCATION	D17-3
SHEET SIZE	11 x 7 + 1/2	CAP.	1	ORDER NO.	974546
CUSTOMER	Embassy Suites			DUE DATE	

QUANTITY	250
DATE	3-1-93

RADIUS	3/8
COMPLETED	

TEAR SEAL	.014
BAR SEAL	484

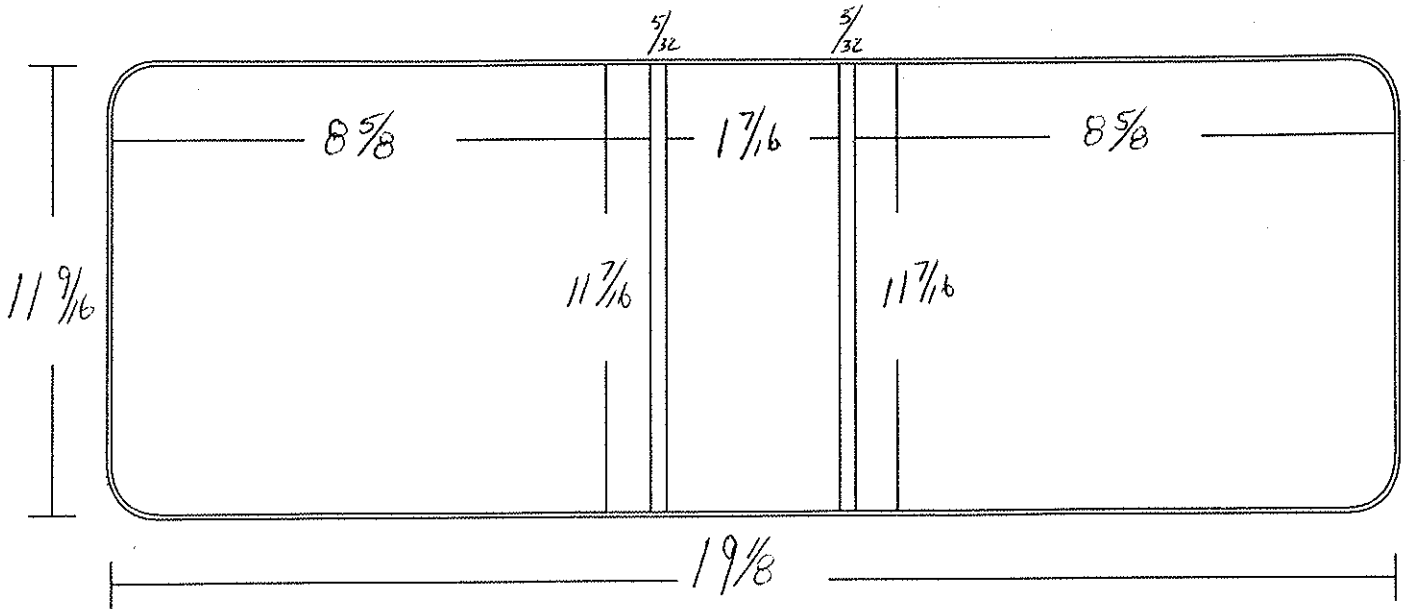

MATERIAL

	CODE		GA	PCS		CODE		GA	PCS
COVER MATL		12 5/16 X 19 7/8		1	LINING		12 5/16 X 19 7/8		1
COVER MATL	Expanded	12 9/16 X 20 1/8			LINING		X		
VERT PKT		X			HORZ PKT		X		
VERT PKT		X			HORZ PKT		X		
CARD HOLDER		X			DIAGONAL PKT		12 3/8 X 9 1/4		1/2
COL		X			LABEL HOLDER		X		
EX. COL		X			GUSSET		X		
		X			REINF.		X		
		X					X		

PRINTS

FRONT COVER	X	BACK BONE	X	BACK COVER	X
-------------	---	-----------	---	------------	---

BOARDS

	CODE		PT	PCS		CODE		PT	PCS
F.C. BOARD		11 1/32 X 8 17/32	120	1	F.C. BOARD		11 3/8 X 8 9/16	100	1
B.B. BOARD		11 1/32 X 1 1/32	720	1	B.B. BOARD		11 3/8 X 1 1/32	100	1
B.C. BOARD		11 1/32 X 8 17/32	120	1	B.C. BOARD		11 3/8 X 8 9/16	100	1
B. UP STRIP		X					X		
2 up Padded diecut		12 1/32 X 18 9/16		2			X		

DIE #	5324	STYLE CASE	VRB	LOCATION	D19-7
SHEET SIZE	11 X 12 $\frac{1}{4}$ + $\frac{1}{2}$	CAP.	3/4	ORDER NO.	975044
CUSTOMER	Quick Scan Inc.			DUE DATE	

QUANTITY	500
DATE	5-4-93

RADIUS	3/8
COMPLETED	

TEAR SEAL	.014
BAR SEAL	484

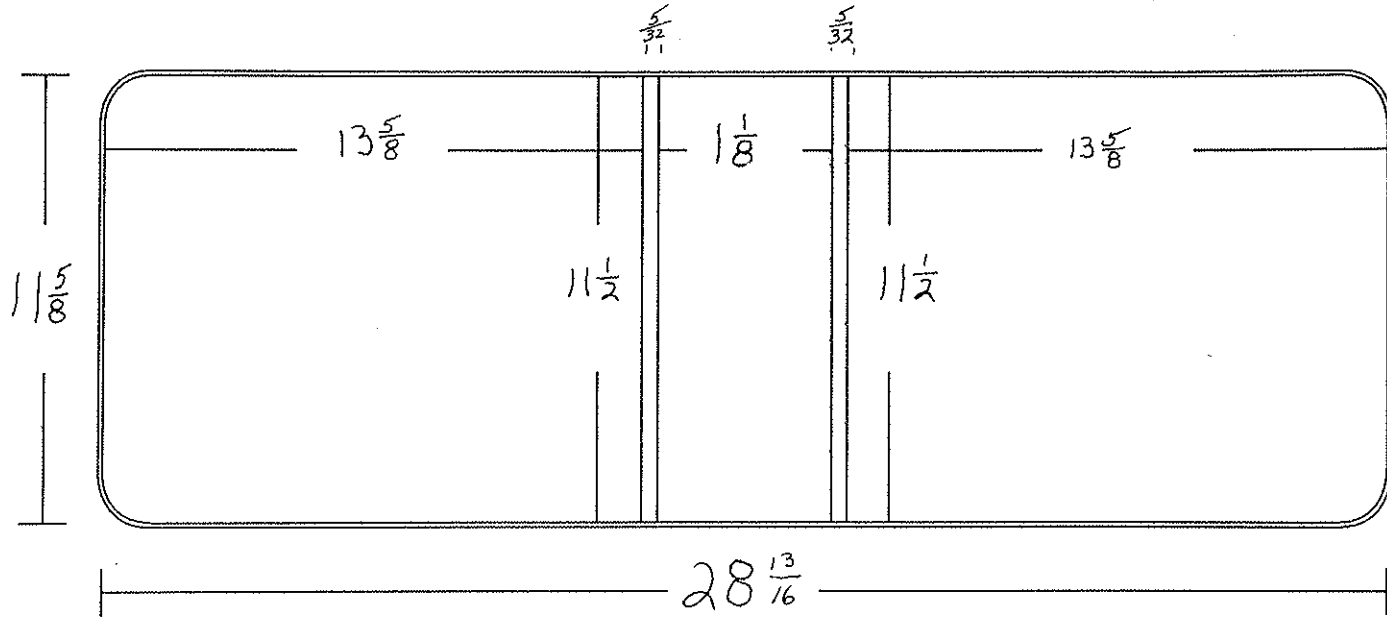

**MATERIAL**

	CODE		GA	PCS		CODE		GA	PCS
COVER MATL		12 $\frac{3}{8}$ X 29 $\frac{9}{16}$		1	LINING		12 $\frac{3}{8}$ X 29 $\frac{9}{16}$		1
COVER MATL		X			LINING		X		
VERT PKT		X			HORZ PKT		5 $\frac{3}{8}$ X 29 $\frac{9}{16}$		1
VERT PKT		X			HORZ PKT		X		
CARD HOLDER		X			DIAGONAL PKT		X		
COL		X			LABEL HOLDER		X		
EX. COL		X			GUSSETT		X		
		X			REINF.		X		
		X					X		

**PRINTS**

FRONT COVER	X	BACK BONE	X	BACK COVER	X
-------------	---	-----------	---	------------	---

**BOARDS**

	CODE		PT	PCS		CODE		PT	PCS
F.C. BOARD		11 $\frac{7}{16}$ X 13 $\frac{9}{16}$	100	1	F.C. BOARD		11 $\frac{13}{32}$ X 13 $\frac{17}{32}$	120	1
B.B. BOARD		11 $\frac{7}{16}$ X 1 $\frac{1}{32}$	100	1	B.B. BOARD		11 $\frac{13}{32}$ X 1 $\frac{1}{32}$	120	1
B.C. BOARD		11 $\frac{7}{16}$ X 13 $\frac{9}{16}$	100	1	B.C. BOARD		11 $\frac{13}{32}$ X 13 $\frac{17}{32}$	120	1
B. UP STRIP		X					X		
		X					X		

DIE # 5408		STYLE CASE VRB		LOCATION 5-9	
SHEET SIZE 11 1/8 X 9 5/16 + 1/2		CAP. 1/2		ORDER # 975874	
CUSTOMER ORANGE LAKE COUNTRY CLUB				DUE DATE	
QUANTITY	5000	RADIUS	3/8	TEAR SEAL	.014
DATE	8-25-93	COMPLETED		BAR SEAL	484

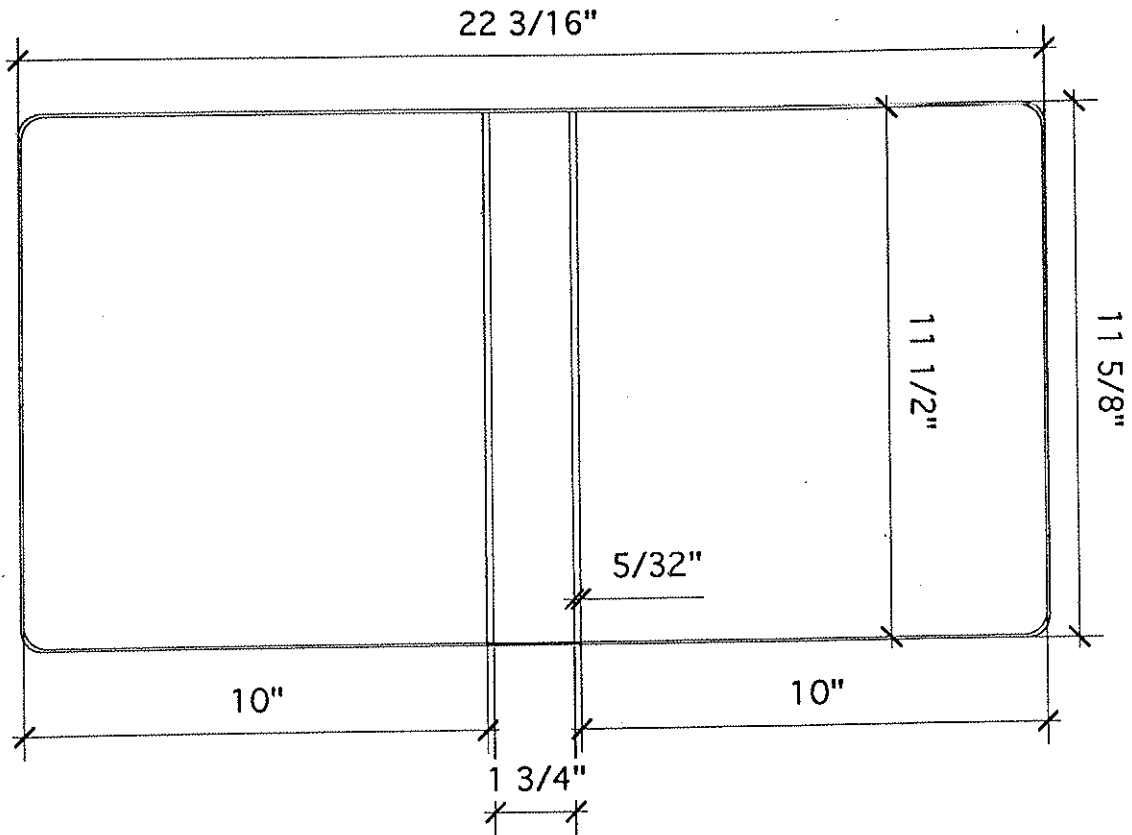

MATERIAL SPECS		GA	PCS			GA	PCS
COVER MATL	12 5/8 X 23 3/16	1		LINING	12 5/8 X 23 3/16	1	
COVER MATL				LINING			
VERT PKT				HORZ PKT	5 1/2 X 10 5/8	1	
VERT PKT				HORZPKT			
CARD HOLDER				DIAGONAL PKT			
COL				LABEL HOLDER			
EX COL				GUSSETT			
				REINF			

BOARD SPECS							
F.C. BOARD	11 13/32 X 9 29/32	120	1	F.C. BOARD			
B.B. BOARD	11 13/32 X 1 21/32	120	1	B.B. BOARD			
B.C. BOARD	11 13/32 X 9 29/32	120	1	B.C. BOARD			
BU STRIP							
Padded Die	# 5408 B						
	12 13/32 x 26 13/32						

NVL - SVR D - 174001092 47516

DIE # 5524	STYLE CASE VINYL RING BINDER <i>Stack</i>	LOCATION
SHEET SIZE 11 X 17 1/2	CAP. 2 1/2	ORDER # 977431
CUSTOMER APPLIED MATERIALS INC		DUE DATE
QUANTITY 50	RADIUS 3/8	TEAR SEAL .012
DATE	COMPLETED	BAR SEAL 484

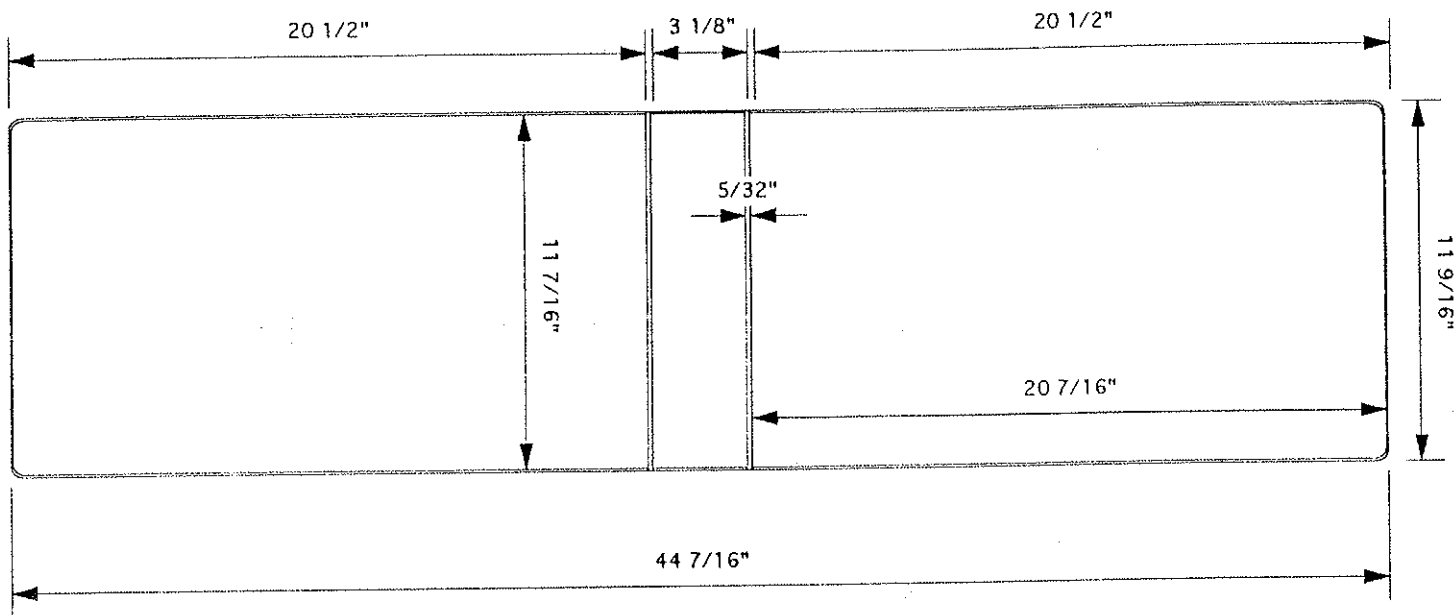

MATERIAL SPECS		GA	PCS	GA		PCS
COVER MATL	12 5/16 X 45 1/4	1	LINING	12 5/16 X 45 1/4	1	
COVER MATL			LINING			
VERT PKT			HORZ PKT			
VERT PKT			HORZPKT			
CARD HOLDER			DIAGONAL PKT			
COL	11 3/4 X 24 3/8	1	LABEL HOLDER			
EX COL			GUSSETT			
			REINF			

BOARD SPECS						
F.C. BOARD	11 3/8	X 20 3/8	120	1	F.C. BOARD	
B.B. BOARD	11 3/8	X 3 1/32	120	1	B.B. BOARD	
B.C. BOARD	11 3/8	X 20 3/8	120	1	B.C. BOARD	
BU STRIP						

*Advtg. Angle D*

DIE #	5678	STYLE CASE	VINYL RING BINDER	LOCATION	E-15-5
SHEET SIZE	11 X 9 3/4	CAP.	2"	ORDER #	979511
CUSTOMER	JAMES O'NEAL & CO.			DUE DATE	10-21-94
QUANTITY	50	RADIUS	3/8	TEAR SEAL	.014
DATE	10-5-94	COMPLETED		BAR SEAL	48-4

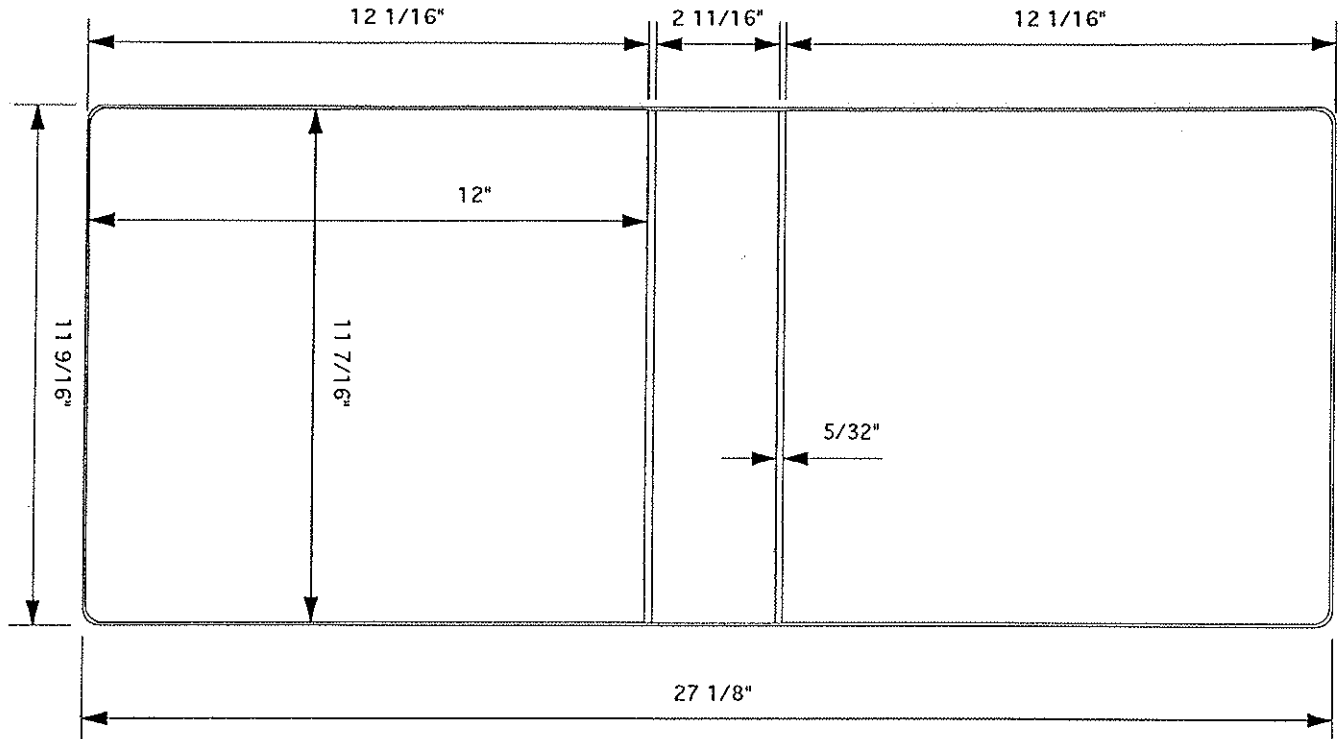

MATERIAL SPECS		GA		PCS	
COVER MATL	12 5/16 X 27 7/8	1	LINING	12 5/16 X 27 7/8	1
COVER MATL			LINING		
VERT PKT			HORZ PKT	5 3/8 X 12 5/8	1
VERT PKT			HORZPKT		
CARD HOLDER	2 3/8 X 4	1	DIAGONAL PKT		
COL			LABEL HOLDER	11 11/16 X 3 1/2	1
EX COL			GUSSETT		
			REINF		

BOARD SPECS					
F.C. BOARD	11 11/32 X 11 29/32	120	1	F.C. BOARD	
B.B. BOARD	11 11/32 X 2 19/32	120	1	B.B. BOARD	
B.C. BOARD	11 11/32 X 11 29/32	120	1	B.C. BOARD	
BU STRIP					

DIE # <b>5699</b>		CAP. <b>1/2</b>		METAL <b>1/2 LOC</b>	
STYLE CASE <b>VINYL RING BINDER</b>				LOCATION <b>E-16-6</b>	
SHEET SIZE <b>11 1/2 X 4 1/2</b>			ORDER # <b>979713</b>		
CUSTOMER <b>CENTRAL TELEPHONE</b>				DUE DATE <b>11-11-94</b>	
QUANTITY	100	RADIUS	3/8	TEAR SEAL	.014
DATE	10-24-94	COMPLETED		BAR SEAL	48-4

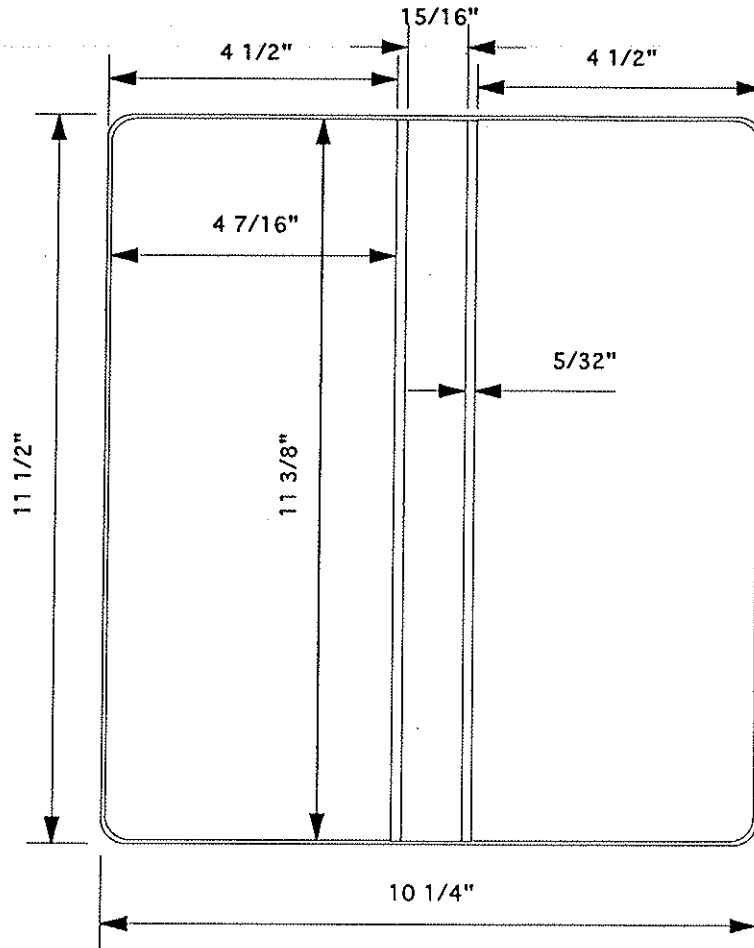

MATERIAL SPECS		GA	PCS	MATERIAL SPECS		GA	PCS
COVER MAT.	12 1/4 X 11		1	LINING MAT	12 1/4 X 11		1
COVER MAT.				LINING MAT			
VERT PKT				HORZ PKT			
CARD HOLDER				GUSSET			
COL				DIAGONAL PKT			
LABEL HOLDER				REINF			

BOARD SPECS		GA	PCS	BOARD SPECS		GA	PCS
F.C. BOARD	11 5/16 X 4 3/8	100	1	F.C. BOARD			
B.B. BOARD	11 5/16 X 27/32	100	1	B.B. BOARD			
B.C. BOARD	11 5/16 X 4 3/8	100	1	B.C. BOARD			
B.U. STRIP							

Match Sample

DIE # 5717		CAP. 1 1/2		METAL LOC	
STYLE CASE VINYL RING BINDER				LOCATION E-17-4	
SHEET SIZE 11 X 9 1/2			ORDER # 69506		
CUSTOMER EBSCO MEDIA ADVERTISING				DUE DATE 12-09-94	
QUANTITY	200	RADIUS	3/8	TEAR SEAL	.014
DATE	11-07-94	COMPLETED		BAR SEAL	253

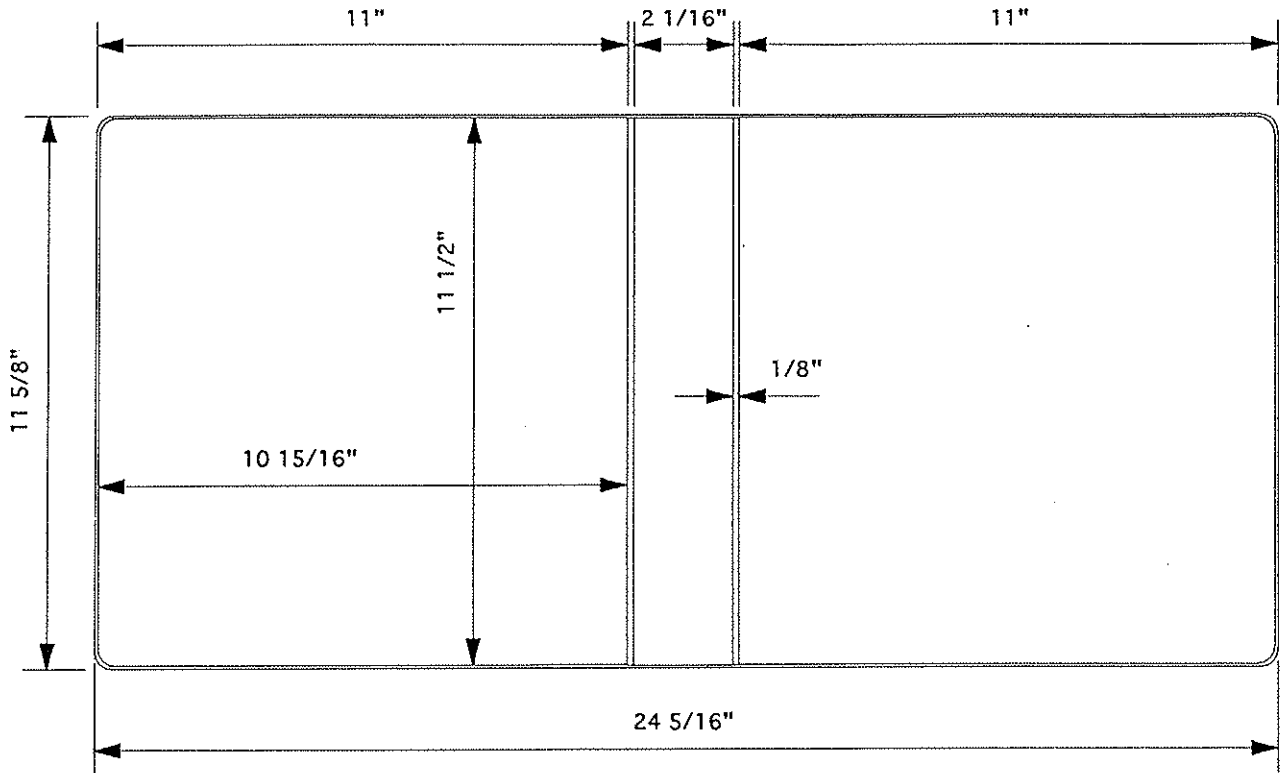

MATERIAL SPECS		GA	PCS			GA	PCS
COVER MAT.	12 3/8 X 25 1/16		1	LINING MAT	12 3/8 X 25 1/16		1
COVER MAT.				LINING MAT			
VERT PKT				HORZ PKT			
CARD HOLDER				GUSSET			
Pictorial	12 3/8 X 25 1/16		1	DIAGONAL PKT			
LABEL HOLDER				REINF			

BOARD SPECS		GA	PCS			GA	PCS
F.C. BOARD	11 13/32 X 10 27/32	120	1	F.C. BOARD			
B.B. BOARD	11 13/32 X 1 31/32	120	1	B.B. BOARD			
B.C. BOARD	11 13/32 X 10 27/32	120	1	B.C. BOARD			
B.U. STRIP							



DIE # 5724		CAP. 1 1/2		METAL 1 1/2 STR. D	
STYLE CASE VINYL 3PC PICTORIAL BINDER				LOCATION E-17-8	
SHEET SIZE 11 X 9			ORDER # 980097		
CUSTOMER KOENIG & ASSOC.				DUE DATE 1-05-95	
QUANTITY	501	RADIUS	3/8	TEAR SEAL	.014 SEE NOTE
DATE	12-8-94	COMPLETED		BAR SEAL	254

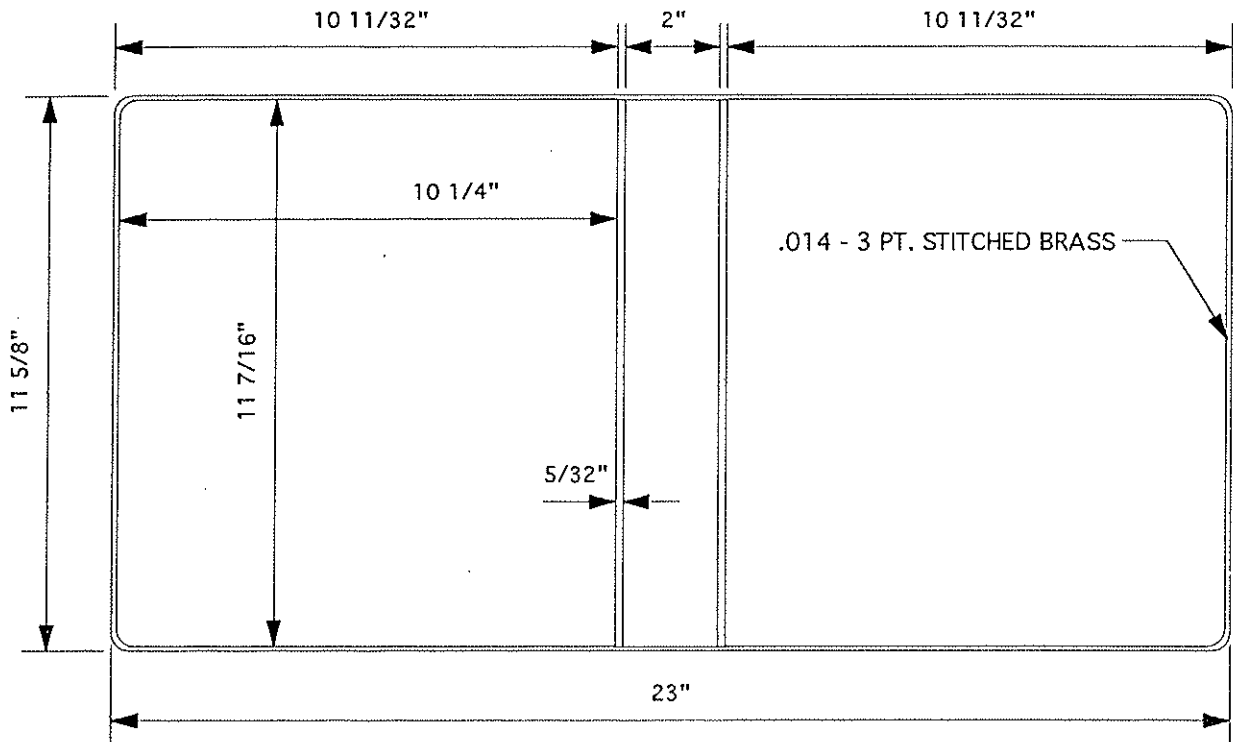

MATERIAL SPECS		GA	PCS			GA	PCS
COVER MAT.	12 3/8 X 23 3/4	V306	1	LINING MAT	12 3/8 X 23 3/4	V306	1
PICTORIAL.	12 3/8 X 23 3/4	8GA (POL CLR)	1	LINING MAT			
VERT PKT				HORZ PKT	5 3/8 X 10 15/16	V306	1
CARD HOLDER				GUSSET			
COL				DIAGONAL PKT			
LABEL HOLDER				REINF			

BOARD SPECS		GA	PCS			GA	PCS
F.C. BOARD	11 3/8 X 10 3/16	100	1	F.C. BOARD			
B.B. BOARD	(B.B. TO BE DIE CUT- 5724-B)			B.B. BOARD			
B.C. BOARD	11 3/8 X 10 3/16	100	1	B.C. BOARD			
B.U. STRIP							



DIE #	5879	METAL	STR D NB	RADIUS	3/8
ORDER #	982142	CUSTOMER	SAM STEWART FORMAL WEAR	TEAR SEAL	.014
SHEET SIZE	11 X 13	STYLE CASE	VINYL RING BINDER	BAR SEAL	253
CAP.	1 1/2"	DUE DATE	8-4-95	COMPLETED	
LOCATION	F-10-2	QUANTITY	150	DATE	7-31-95

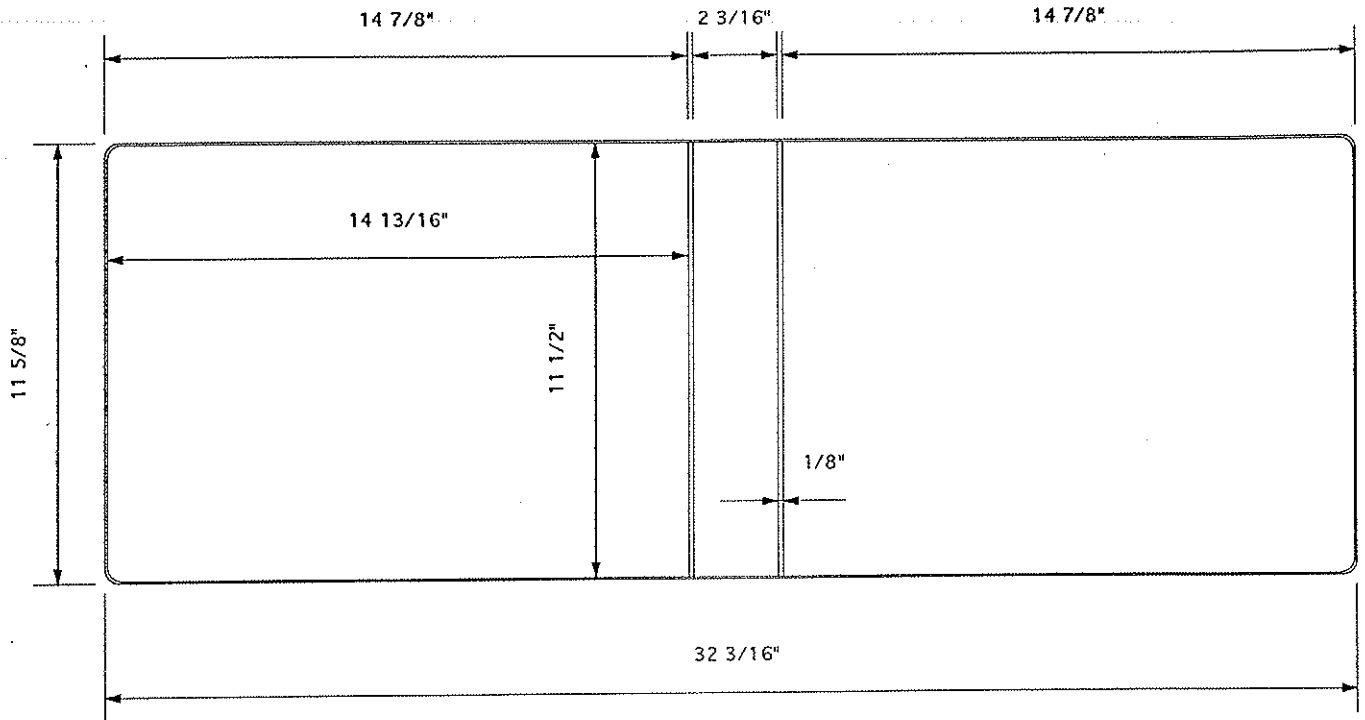

MATERIAL SPECS		GAUGE		PCS.		MATERIAL SPECS		GAUGE	
COVER MAT.	12 5/8 X 33 1/4			1		LINING MAT.	12 3/8 X 33		
COVER MAT.						LINING MAT.			
DIE CUT						HORZ. PKT.			
COL						VERT. PKT.			
LABEL HOLDER						DIE CUT			
GUSSET						REINF.			

BOARD SPECS		GAUGE		PCS.		BOARD SPECS		GAUGE	
F.C. BOARD	11 13/32 X 14 23/32	PADEED	120	1		F.C. BOARD			
B.B. BOARD	11 13/32 X 2 3/32	PADEED	120	1		B.B. BOARD			
B.C. BOARD	11 13/32 X 14 23/32	PADEED	120	1		B.C. BOARD			
B.U. STRIP						DIE CUT			
DIE CUT						DIE CUT			

2-up die # 5948

DIE #	5904	METAL	HOC	RADIUS	3/8
ORDER #	982804	CUSTOMER	REDBOOK	TEAR SEAL	.014
SHEET SIZE	11 X 7 1/2	STYLE CASE	VINYL RING BINDER	BAR SEAL	48-4
CAP.	1 1/2	DUE DATE	12-28-95	COMPLETED	
LOCATION	X-1-4	QUANTITY	35000	DATE	11-6-95

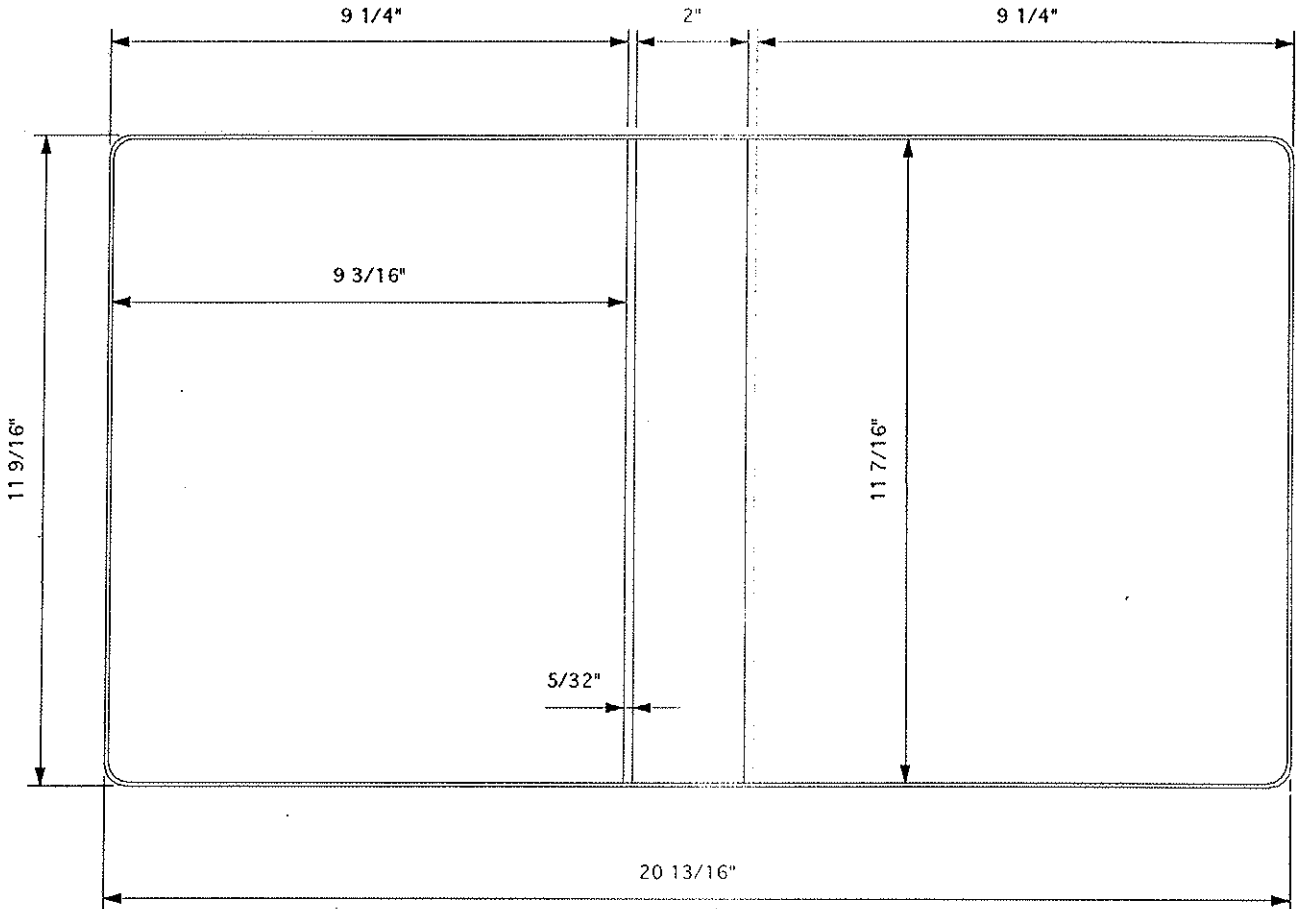

ALUMINUM BASE DIE

MATERIAL SPECS		GAUGE		PCS.		MATERIAL SPECS		GAUGE	
COVER MAT.	12 9/16 X 21 13/16		1	LINING MAT.	12 1/4 X 21 13/16				
COVER MAT.				LINING MAT.					
DIE CUT				<del>HORZ. PKT.</del>	12 1/4 X 3				
COL				VERT. PKT.					
LABEL HOLDER				DIE CUT					
GUSSET				REINF.					

BOARD SPECS		GAUGE		PCS.		BOARD SPECS		GAUGE	
F.C. BOARD	11 11/32 X 9 3/32 PADDED	100	1	F.C. BOARD					
B.B. BOARD	11 11/32 X 1 29/32 PADDED	100	1	B.B. BOARD					
B.C. BOARD	11 11/32 X 9 3/32 PADDED	100	1	B.C. BOARD					
B.U. STRIP				DIE CUT					
DIE CUT				DIE CUT					