

Stock A4

Product Code

Style Case Ring Binders

Sheet Size 11 3/4 x 5 3/4 Cap. 1

Die No. 7221

Order No. 362004

Plate

Customer	Cavi Tonio Cerioli + C.A.S.A.	
Metal		
Total Vinyl	.030	
Quantity	1000	
Date	11-24-78	
Type Corners	RD	
Radius	1/4	
Completed		

	Gauge	Thick
Tear Seal	.016	3/32
Bar Seal	.103	3/32
Bar Seal		

	No. of Feet
Tear Seal	5 1/2
Bar Seal	2
Bar Seal	

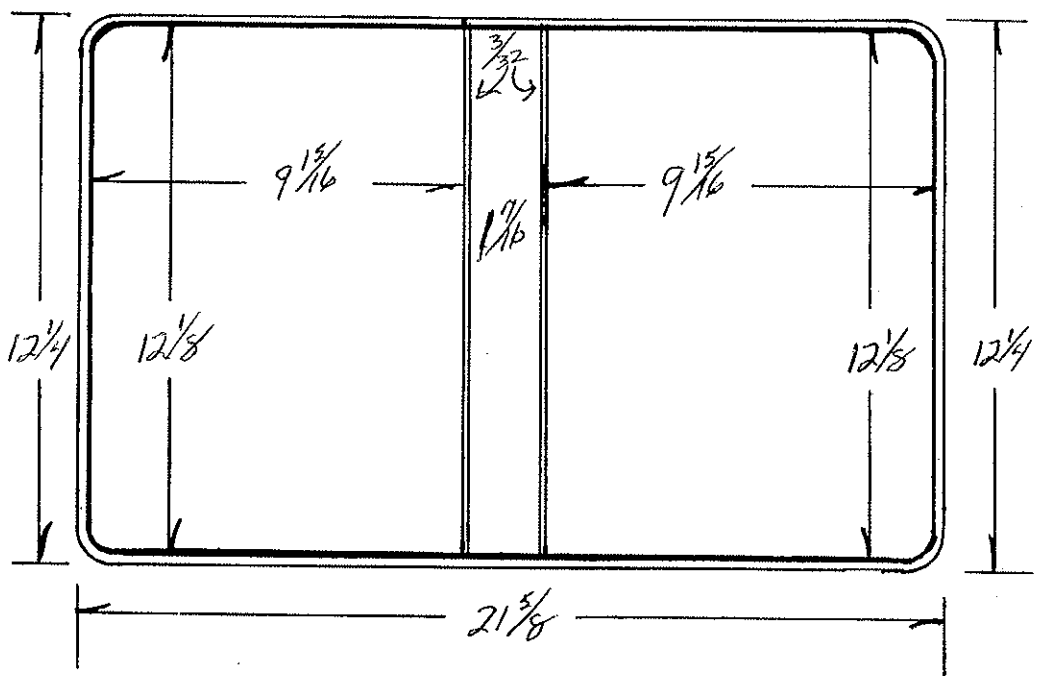

Code	Cutting Specs				Code	Cutting Specs			
	Ga.	PCS	Size	Out		Ga.	Pcs.	Size	Out
Cover Mat.		1	12 7/8 X 22 1/2		Lining Mat.		1	12 7/8 X 22 1/2	
Cover Mat			X 22 1/2		Lining Mat.			X 22 1/2	
Vert. Pckt.			X		Horz. Pckt.			4 7/8 X 22 1/4	
Vert. Pckt.			X		Horz. Pckt.			X	
Pocket			X		Pocket	EX COL		12 3/8 X 12 5/8	
Label Holder			X		Card Holder			X	
Material			X		Material			X	
Material			X		Material			X	
Material			X		Material			X	
B.C. Board		100	12 1/32 X 9 27/32	1	B.C. Board		100	12 1/32 X 9 27/32	1
B.C. Board		100	12 1/16 X 9 7/8		B.B. Board		100	12 1/32 X 1 1/32	
Center Board			X		Board		100	12 1/16 X 1 1/32	
Board			X		Strip			X	
Cover Pad			X		Strip			X	
Padded Bd	FC-BB-BC #		2201A		B.B. Pad			X	
			14 7/8 X 21 3/16						

Product Code

Style Case ST, O VRS.

Sheet Size 11 3/4 x 9

Cap. 2"

Dia No. 4118

Order No. 961374-1 Plate

Customer VARCO - BJ

Metal
Total Vinyl
Quantity
Date 1-9-89
Type Corners RNO
Radius 3/8
Completed 1-24-89

	Gauge	Thick
Tear Seal	016	3/32
Bar Seal		5/32
Bar Seal		

	No. of Feet
Tear Seal	
Bar Seal	
Bar Seal	

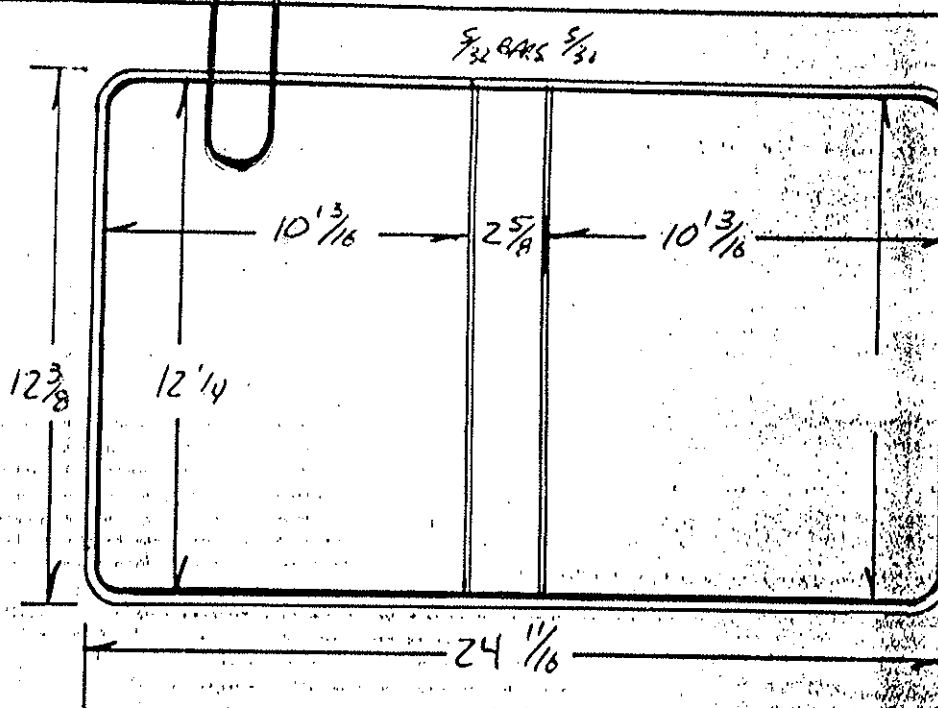

* USE PICTORIAL DIE # 4119

Code	Cutting Specs				Code	Gau.	PCS	Size	Out					
	Ga.	PCS	Size	Out										
Cover Mat.			13 1/8 x 25 1/2	15	1				Lining Mat.			13 1/8 x 25 1/2	15	1
Cover Mat.			X						Lining Mat.			X		
Vert. Pckt.			X						Horz. Pckt.			X		
Vert. Pckt.			X						Horz. Pckt.			X		
Pocket	EX COL		12 1/2 x 14 3/8						Pocket			X		
Label Holder			CUT CORNERS DGS						Card Holder			X		
Material			X						Material			13 1/8 x 11 1/8		
Material			X						Material			13 1/8 x 3 9/8	8	
Material			X						Material			X		
F.C. Board			12 5/32 x 10 23/32	100	1				B.C. Board			X		
B.C. Board			12 5/32 x 10 23/32	100	1				B.B. Board			12 5/32 x 2 17/32	100	1
Center Board			12 3/16 x 10 3/4	100	2				Board			X		
Board			12 3/16 x 2 17/32	100	1				Strip			X		
Cover Pad			X						Strip			X		
									B.B. Pad			X		

Product Code

Sheet Size $11\frac{3}{4} \times 9$

Cap. 1

Die No. 4116

Style Case ST. O VRB

Order No. 961375-1 Plate

Customer VARCO B.J.

Metal
Total Vinyl
Quantity
Date 1-9-84
Type Corners RND
Radius 3/8
Completed 23-89

	Gauge	Thick
Tear Seal	16	3/16
Bar Seal		3/16
Bar Seal		3/16

	No. of Feet
Tear Seal	
Bar Seal	
Bar Seal	

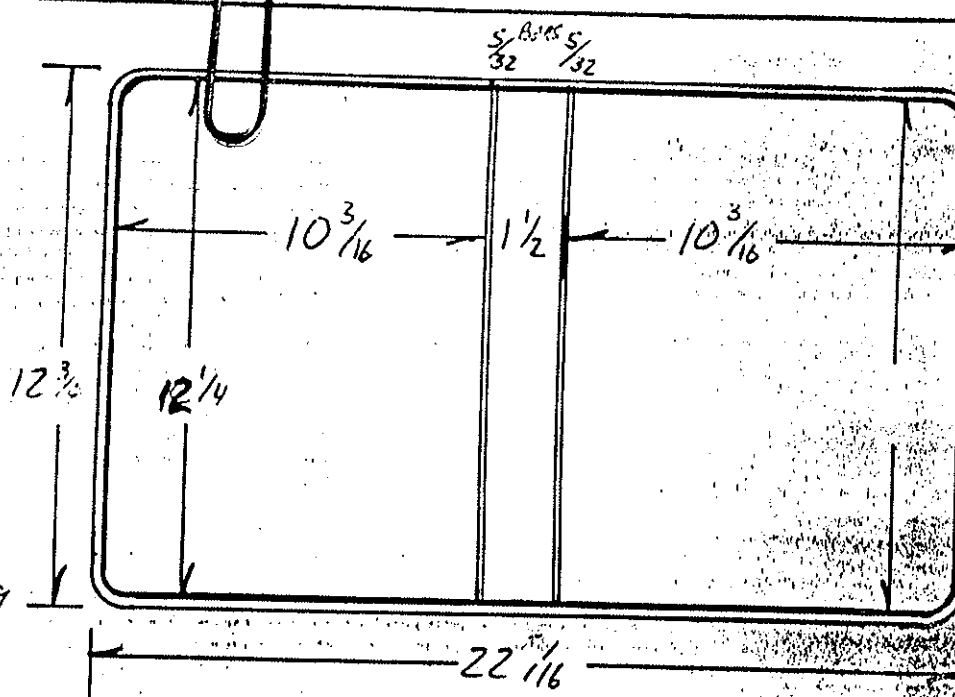

* USE PICTORIAL DIE # 4119

Code		Cutting Specs		Code		Code	
		Ga.	PCS	Size	cut.	Ga.	Pcs.
Cover Mat.	$13\frac{1}{8} \times 23\frac{3}{8}$	15	1			Lining Mat.	$13\frac{1}{8} \times 23\frac{3}{8}$ 15 1
Cover Mat	X					Lining Mat.	X
Vert. Pckt.	X					Horz. Pckt.	X
Vert. Rckt.	$12\frac{9}{16} \times 12\frac{9}{16}$					Horz. Pckt.	X
Pocket	$12\frac{9}{16} \times 23\frac{3}{8}$					Pocket	X
Label Holder	X					Card Holder	X
Material	X					Material (CLEAR)	X
Material	X					Material (PICT.)	$13\frac{1}{8} \times 10\frac{1}{2}$ 8 1
Material	X					Material	$13\frac{1}{8} \times 2\frac{1}{2}$ 8 1
F.C. Board	$12\frac{5}{32} \times 10\frac{3}{32}$	100	1			Material	X (CLEAR)
B.C. Board	$12\frac{5}{32} \times 10\frac{3}{32}$	100	1			B.C. Board	X
Center Board	X					B.B. Board	$12\frac{5}{32} \times 13\frac{1}{32}$ 100 1
Board	X					Board	X
Cover Pad	X					Strip	X
						Strip	X
						B.B. Pad	X

Product Code

OLD LIC # 1064

Style Case

VRB

Sheet Size $11\frac{1}{4} \times 8\frac{1}{4}$ Cap. $2\frac{1}{2}$

Die No. 4130

Order No. 961644

Plate

Customer
Metal
Total Vinyl
Quantity
Date
Type Corners
Radius
Completed

	Gauge	Thick
Tear Seal	16	$\frac{23}{32}$
Bar Seal		$\frac{23}{32}$
Bar Seal		

	No. of Feet
Tear Seal	
Bar Seal	
Bar Seal	

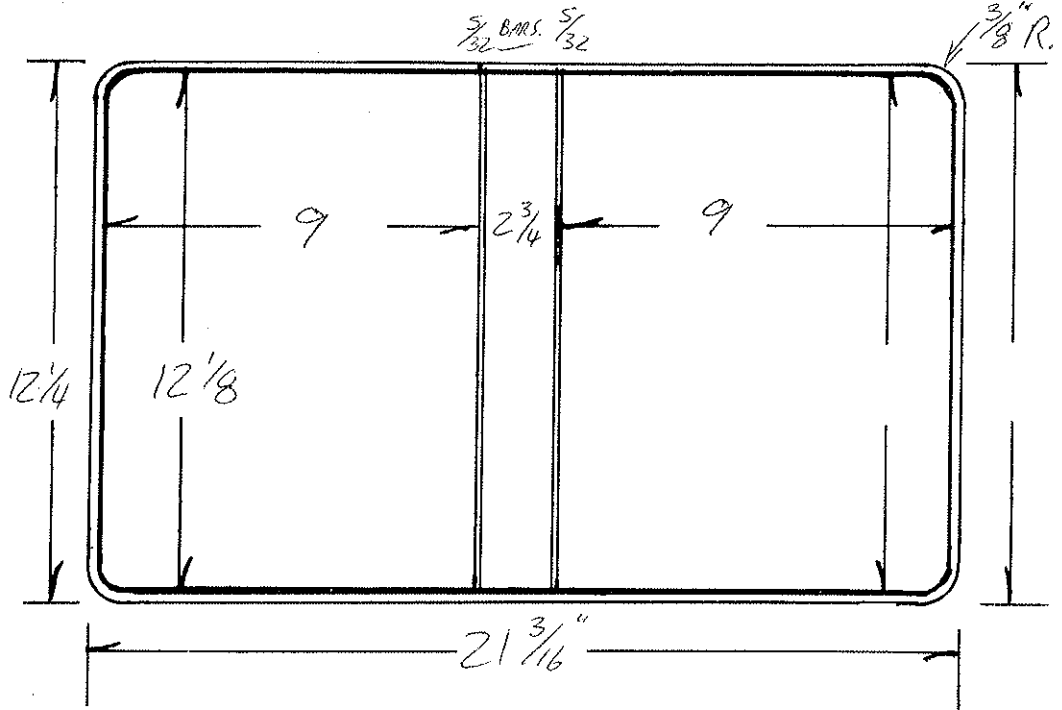

Code	Ga.	#	PCS	Cutting Specs		Code	Ga.	#	PCS	Cutting Specs					
				Size	Out					Size	Out				
Cover Mat.			13	X	22	15	1		Lining Mat.		13	X	22	15	1
Cover Mat.				X					Lining Mat.			X			
Vert. Pckt.				X					Horz. Pckt.			X			
Vert. Pckt.				X					Horz. Pckt.			X			
Pocket				X					Pocket			X			
Label Holder			$3\frac{1}{8}$	X	$3\frac{3}{4}$	8	1		Card Hlder			X			
Material				X					Material			X			
Material				X					Material			X			
Material				X					Material			X			
F.C. Board			$12\frac{1}{32}$	X	$8\frac{29}{32}$	100	1		B.C. Board			X			
B.G. Board			$12\frac{1}{32}$	X	$8\frac{29}{32}$	100	1		B.B. Board		$12\frac{1}{32}$	X	$2\frac{21}{32}$		
Center Board				X					Board			X			
Board				X					Strip			X			
Cover Pad				X					Strip			X			
									B.B. Pad			X			

DIE #	4253	METAL	ANGLE D	RADIUS	3/8
ORDER #		CUSTOMER	GAS TECH ENGINEERING	TEAR SEAL	.014
SHEET SIZE	11 3/4 X 9 1/4	STYLE CASE	VRB	BAR SEAL	253
CAP.	3"	DUE DATE.	3-18-96	COMPLETED	
LOCATION	A-5-4	QUANTITY	250	DATE	6-8-96

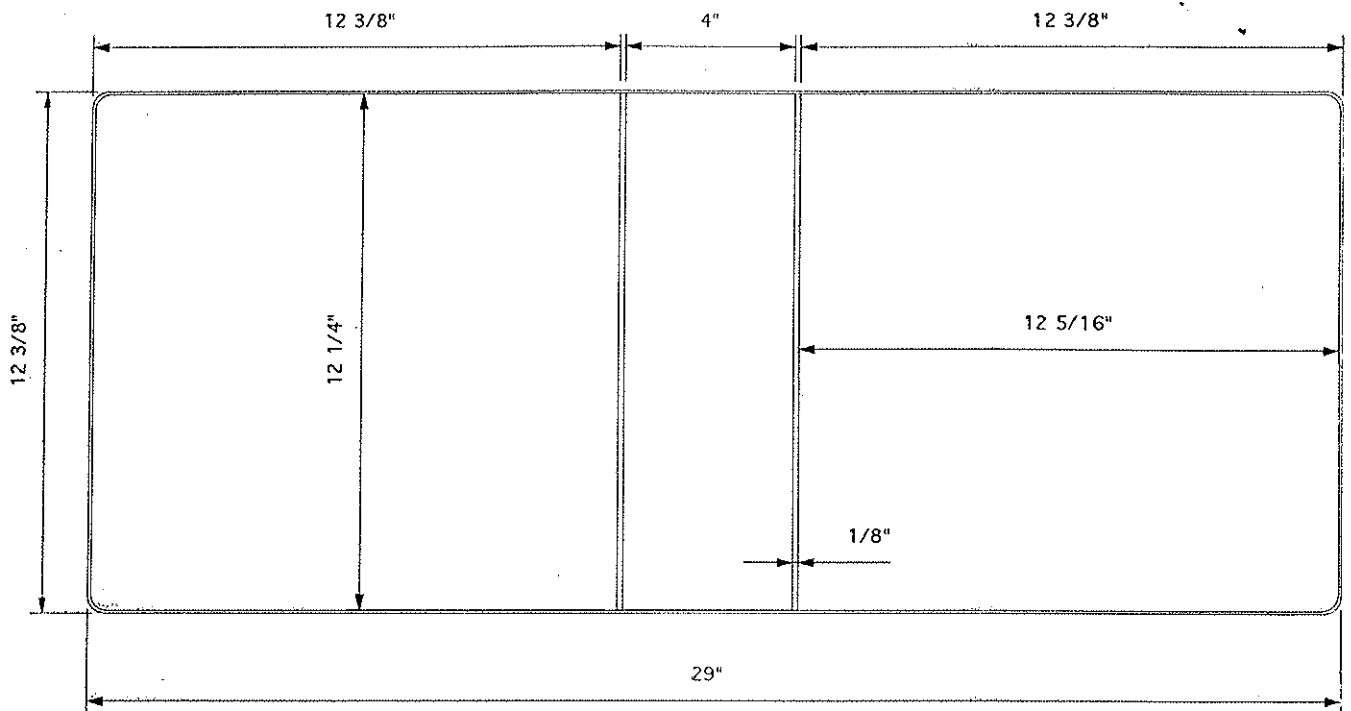

MATERIAL SPECS		GAUGE		PCS.		MATERIAL SPECS		GAUGE	
COVER MAT.	13 1/8 X 29 3/4			1		LINING MAT.	13 1/8 x 29 3/4		
COVER MAT.						LINING MAT.			
DIE CUT						HORZ. PKT.			
COL	12 1/2 X 17 1/8			1		VERT. PKT.			
LABEL HOLDER						DIE CUT			
GUSSET						REINF.			

BOARD SPECS		GAUGE		PCS.		BOARD SPECS		GAUGE	
F.C. BOARD	12 5/32 X 12 7/32	120		1		F.C. BOARD			
B.B. BOARD	12 5/32 X 3 29/32	120		1		B.B. BOARD			
B.C. BOARD	12 5/32 X 12 7/32	120		1		B.C. BOARD			
B.U. STRIP						DIE CUT			
DIE CUT						DIE CUT			

Product Code Sample

OLD # 2933

Style Case VINYL CASSETTE HOLD

ACTUAL
Sheet Size 11³/₄ X 10¹/₄

Cap. 1¹/₄

Die No. 4260

Order No. 963271.1

Plate

Customer

PAYNE & PAYNE

Metal
Total Vinyl
Quantity <u>1,000</u>
Date <u>8-11-89</u>
Type Corners <u>RND</u>
Radius <u>3/8"</u>
Completed

	Gauge	Thick
Tear Seal	<u>016</u>	<u>7/32"</u>
Bar Seal	<u>#178</u>	<u>3/16</u>
Bar Seal		

	No. of Feet
Tear Seal	
Bar Seal	
Bar Seal	

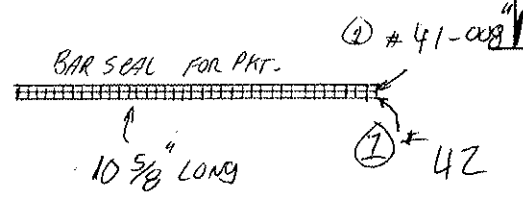
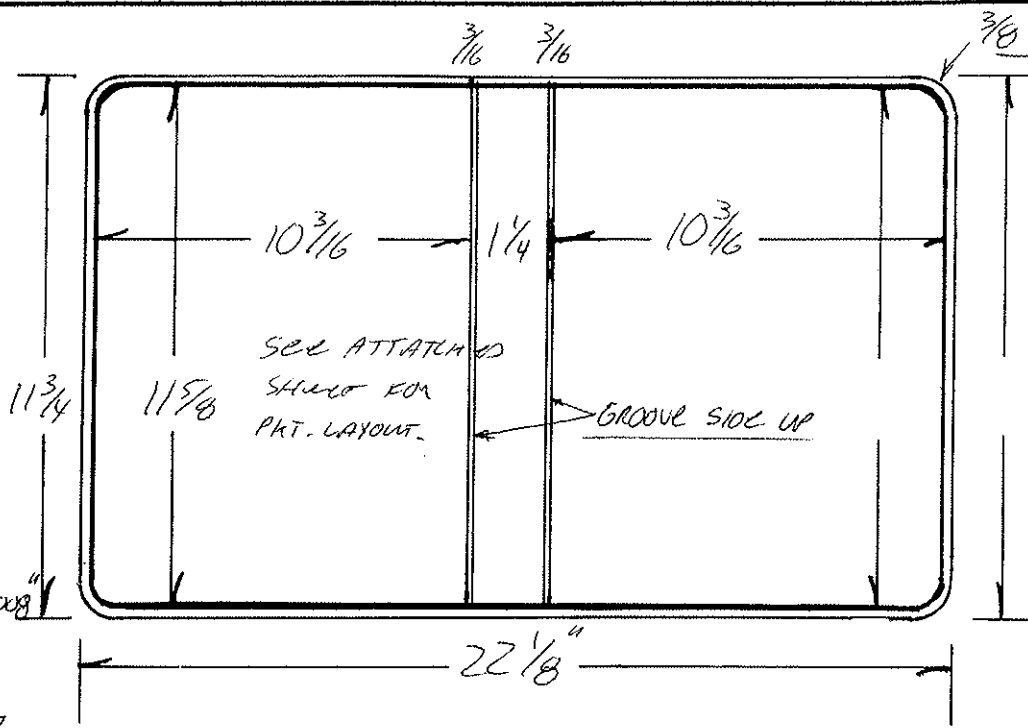

Code		Cutting Specs		Ga.	PCS	Size	Out	Code		Cutting Specs		Ga.	PCS	Size	Out
Cover Mat.		$12\frac{1}{2}$ X	23	15	1			Lining Mat.		$12\frac{1}{2}$ X	23	15	1		
Cover Mat.			X					Lining Mat.			X				
Vert. Pckt.			X					Horz. Pckt.			X				
Vert. Pckt.			X					Horz. Pckt.			X				
Pocket	#1	9" X	$10\frac{5}{8}$	8	1			Pocket	#2	9" X	$5\frac{1}{8}$	8	1		
Label Holder			X					Card Hlder	#3	$5\frac{3}{4}$ X	5	8	1		
Material			X					Material			X				
Material			X					Material			X				
Material			X					Material			X				
F.C. Board		$11\frac{1}{32}$ X	$10\frac{3}{32}$	100	1			B.C. Board			X				
B.G. Board		$11\frac{1}{32}$ X	$10\frac{3}{32}$	100	1			B.B. Board		$11\frac{1}{32}$ X	$1\frac{9}{32}$	100	1		
Center Board			X					Board			X				
Board			X					Strip			X				
Cover Pad			X					Strip			X				
								B.B. Pad			X				

Product Code Sample

Style Case TMPI BINDER

ACTUAL Sheet Size 11 9/16 x 9 1/2 Cap. 2 7/8

Die No. 4262

Order No. 963355

Plate

K-DOT ASSOCIATES

Customer
Metal
Total Vinyl
Quantity
Date
Type Corners
Radius
Completed

	Gauge	Thick
Tear Seal		
Bar Seal		
Bar Seal		

	No. of Feet
Tear Seal	
Bar Seal	
Bar Seal	

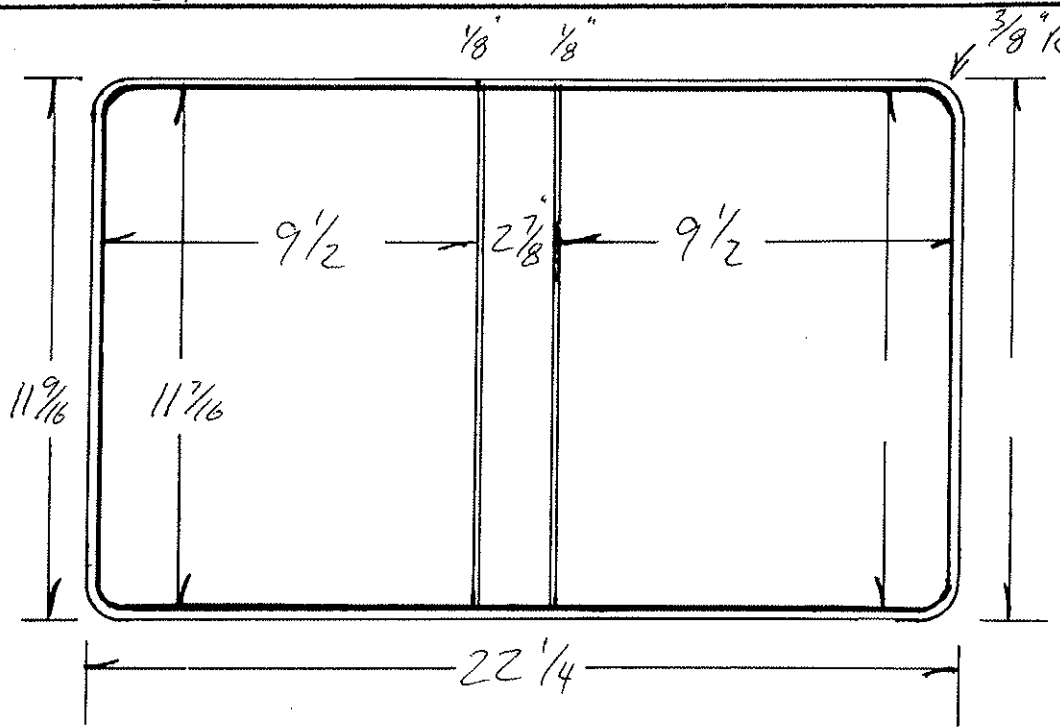

2-TMPI METALS ON SPINE
FOR 2-PHONE BOOKS
10 3/16 X 9 9/16 - 1 7/16 - 1 3/8

Code	Ga.	PCS	Cutting Specs		Code	Ga.	Pcs.	Cutting Specs	
			Size	Out				Size	Out
Cover Mat.		12 1/4 X 23	15	1	Lining Mat.		12 1/4 X 23	15	1
Cover Mat.		X			Lining Mat.		X		
Vert. Pckt.		X			Horz. Pckt.		X		
Vert. Pckt.		X			Horz. Pckt. I.F.C.	6 3/8 X 10	8	1	
Pocket		X			Pocket		X		
Label Holder		X			Card Holder		X		
Material		X			Material		X		
Material		X			Material		X		
Material		X			Material		X		
F.C. Board		11 1/32 X 9 1/32	120	1	B.C. Board		X		
B.C. Board		11 1/32 X 9 1/32	120	1	B.B. Board	X X	11 1/32 X 2 25/32	120	1
Center Board		X			Board		X		
Board		X			Strip		GRAN X		
Cover Pad		X			Strip		DIRECTOR !		
					B.B. Pad		X		

Product Code

Style Case *VRB*

Sheet Size * *11 1/2 x 9*

Cap. *2"*

Die No. *4417*

Order No. *96538081*

Plate

DANKAERT

Customer
Metal
Total Vinyl
Quantity
Date
Type Corners
Radius
Completed

	Gauge	Thick
Tear Seal	<i>.014</i>	<i>1/16</i>
Bar Seal		
Bar Seal		

	No. of Feet
Tear Seal	
Bar Seal	
Bar Seal	

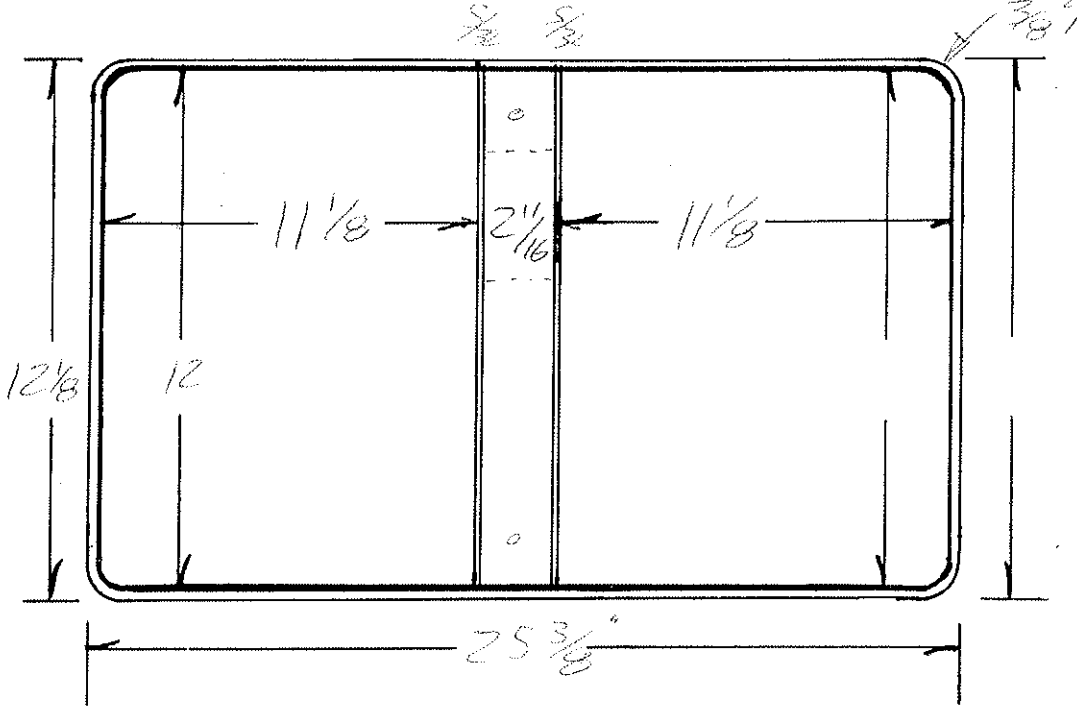

Size - Blank
Check - YPI

Code	Cutting Specs				Code	Cutting Specs							
	Ga.	# PCS	Size	# Out		Ga.	# Pcs.	Size	# Out				
Cover Mat.		<i>13</i>	<i>x 26 1/4</i>	<i>15</i>	<i>1</i>	Lining Mat.		<i>13</i>	<i>x 26 1/4</i>	<i>15</i>	<i>1</i>		
Cover Mat			X			Lining Mat.			X				
Vert. Pckt.			X			Horz. Pckt.			X				
Vert. Pckt.			X			Horz. Pckt.			X				
Pocket			X			Pocket			X				
Label Holder		<i>3 1/8</i>	<i>x 3 3/4</i>	<i>8</i>	<i>1</i>	Card Holder			X				
Material			X			Material			X				
Material			X			Material			X				
Material			X			Material			X				
F.C. Board		<i>11 29/32</i>	<i>x 11 1/32</i>		<i>1</i>	B.C. Board			X				
B.C. Board		<i>11 29/32</i>	<i>x 11 1/32</i>		<i>1</i>	B.B. Board		<i>11 29/32</i>	<i>x 2 19/32</i>			<i>1</i>	
Center Board			X			Board			X				
Board			X			Strip			X				
Cover Pad			X			Strip			X				
						B.B. Pad			X				

Product Code

Style Case VRB 12-4-2 1/2 A-D L.L.

Sheet Size 11 5/8 X 8 7/8 Cap. 2 1/2 A.D. Die No. 4769

Order No. 968732 Plate C-15-

Customer

FISKARS MFG. CO.

Metal	
Total Vinyl	
Quantity	100
Date	5-20-91
Type Corners	
Radius	3/8"
Completed	

	Gauge	Thick
Tear Seal	.014	1/16
Bar Seal	48-4	5/32
Bar Seal		

	No. of Feet
Tear Seal	
Bar Seal	
Bar Seal	

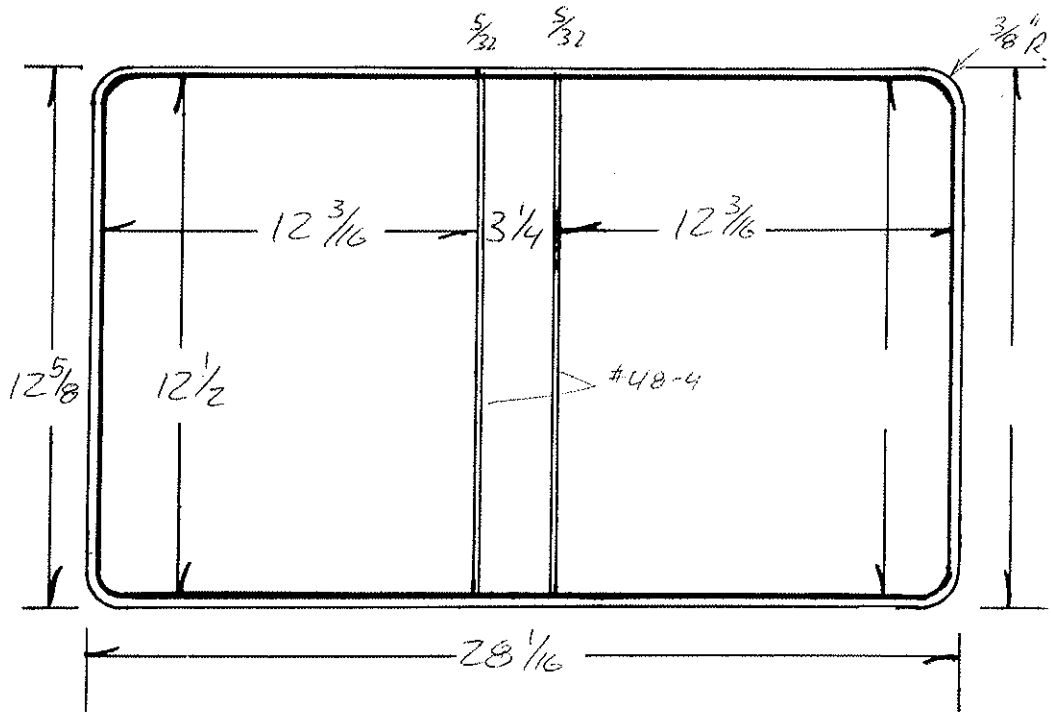

DWG. - B. Price
 CHECK - KPV

VRB = 12 3/8" HL TO FIT METAL

SHEET SIZE PER LEAD

Code	Ga.	PCS	Cutting Specs		Code	Ga.	Pcs.	Cutting Specs				
			Size	Out				Size	Out			
Cover Mat.			13 3/8"	28 7/8"	15	1	Lining Mat.			13 3/8" X 28 7/8"	15	1
Cover Mat.			X				Lining Mat.			X		
Vert. Pckt.			X				Horz. Pckt.			X		
Vert. Pckt.			X				Horz. Pckt.			X		
Pocket			X				Pocket			X		
Label Holder			X				Card Holder			X		
Material			X				Material			X		
Material			X				Material			X		
Material			X				Material			X		
F.C. Board			12 13/32"	12 3/32"	120	1	B.C. Board			X		
B.G. Board			12 13/32"	12 3/32"	120	1	B.B. Board			12 13/32" X 3 5/32"	100	1
Center Board			X				Board			12 13/32" X 3 5/32"	48	1
Board			X				Strip			X		
Cover Pad			X				Strip			X		
							B.B. Pad			X		

Product Code

Stock A-4

Style Case STR. D. VRB

Sheet Size $11\frac{3}{4} \times 8\frac{3}{4}$ Cap. $1\frac{1}{2} D$ Die No. 4779 Order No. 969058 Plate C-15-5

Customer

TOM WHEATLEY CO.

Metal
Total Vinyl
Quantity 50
Date 5-31-91
Type Corners
Radius $\frac{3}{8}$
Completed

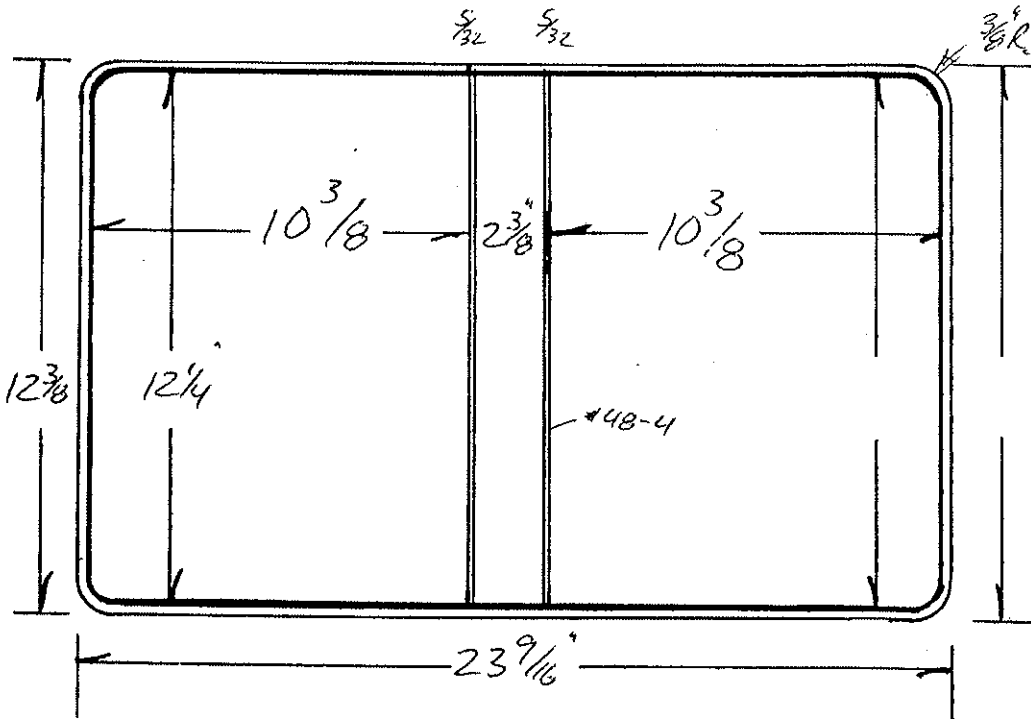

	Gauge	Thick
Tear Seal	.014	$\frac{1}{16}$
Bar Seal	#484	$\frac{5}{32}$
Bar Seal		

	No. of Feet
Tear Seal	
Bar Seal	
Bar Seal	

Dwg - B. P. [Signature]
 Check [Signature]

Code		Cutting Specs		Code		Cutting Specs			
		Ga.	Pcs	Size	Out	Ga.	Pcs	Size	Out
Cover Mat.	$13\frac{1}{8} \times 24\frac{1}{4}$	15	1			Lining Mat.	$13\frac{1}{8} \times 24\frac{1}{4}$	15	1
Cover Mat.	X					Lining Mat.	X		
Vert. Pckt.	X					Horz. Pckt.	$5\frac{3}{8} \times 24\frac{1}{4}$		
Vert. Pckt.	X					Horz. Pckt.	$4\frac{7}{8} \times 24\frac{1}{4}$		
Pocket	X					Pocket	X		
Label Holder	EX COL $12\frac{1}{2} \times 14$					Card Holder	X		
Material	COL $12\frac{1}{2} \times 24\frac{1}{4}$	8	1			Material	X		
Material	X					Material	X		
Material	X					Material	X		
F.C. Board	$12\frac{5}{32} \times 10\frac{9}{32}$	120	1			B.C. Board	X		
B.G. Board	$12\frac{5}{32} \times 10\frac{9}{32}$	120	1			B.B. Board	$12\frac{5}{32} \times 2\frac{9}{32}$	120	1
Center Board	FC $12\frac{3}{16} \times 10\frac{5}{16}$	100	1			Board	$12\frac{3}{16} \times 2\frac{9}{32}$	100	1
Board	BC $12\frac{3}{16} \times 10\frac{5}{16}$	100	1			Strip	X		
Cover Pad	X					Strip	X		
						B.B. Pad	X		

Product Code JUP Die #6032 stock #4 Style Case STR. D VR3

Sheet Size 11 3/4 x 8 3/4 Cap. Z D Die No. 4780 Order No. 969056 Plate C-15-6

Customer

TOM WHEATEY CO

Metal
Total Vinyl
Quantity <u>50</u>
Date <u>5-31-91</u>
Type Corners
Radius <u>3/8</u>
Completed

	Gauge	Thick
Tear Seal	<u>.014</u>	<u>1/16</u>
Bar Seal	<u>#48-4</u>	<u>5/32</u>
Bar Seal		

	No. of Feet
Tear Seal	
Bar Seal	
Bar Seal	

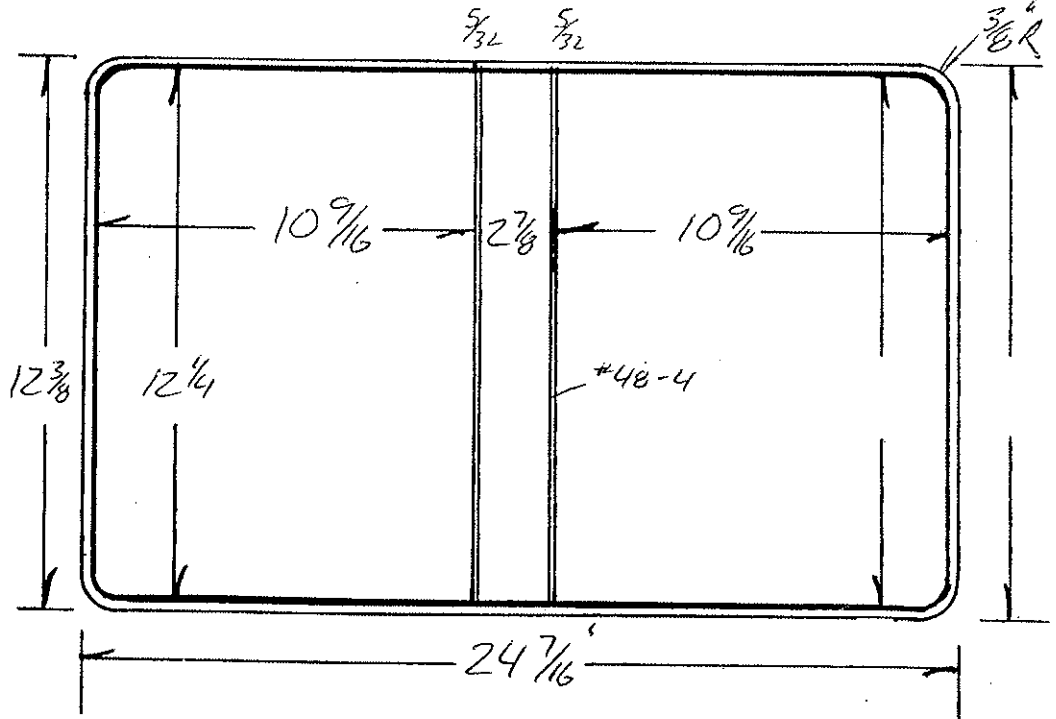

Dwg - B. Pace
Check

Code		Cutting Specs		Code		Cutting Specs			
		Ga.	# PCS	Size	Out	Ga.	# Pcs.	Size	Out
Cover Mat.	<u>13 1/8 x 25 1/4</u>	<u>15</u>	<u>1</u>			Lining Mat.	<u>13 1/8 x 25 1/4</u>	<u>15</u>	<u>1</u>
Cover Mat	X					Lining Mat.	X		
Vert. Pckt.	X					Horz. Pckt.	X		
Vert. Pckt.	X					Horz. Pckt.	<u>4 7/8 x 25 1/4</u>		
Pocket	X					Pocket	X		
Label Holder	<u>5x Coz 12 1/2 x 14 1/16</u>					Card Holder	X		
Material	<u>C.O.L. 12 1/2 x 25 1/4</u>	<u>8</u>	<u>1</u>			Material	X		
Material	X					Material	X		
Material	X					Material	X		
F.C. Board	<u>12 5/32 x 10 15/32</u>	<u>120</u>	<u>1</u>			B.C. Board	X		
B.C. Board	<u>12 5/32 x 10 15/32</u>	<u>120</u>	<u>1</u>			B.B. Board	<u>12 5/32 x 2 25/32</u>	<u>120</u>	<u>1</u>
Center Board	X					Board	X		
Board	X					Strip	X		
Cover Pad	X					Strip	X		
						B.B. Pad	X		

Product Code

Style Case STR. D. VRB

Sheet Size $11\frac{3}{4}$ X $9\frac{3}{4}$ Cap. $2\frac{1}{2}$ D Die No. 4781

Order No. 969057

Plate C-15-7

Customer

TOM WHEATY CO

Metal
Total Vinyl
Quantity 50
Date 5-31-91
Type Corners
Radius $\frac{3}{8}$ "
Completed

	Gauge	Thick
Tear Seal	.014	$\frac{1}{16}$ "
Bar Seal	+48-4	$\frac{5}{32}$ "
Bar Seal		

	No. of Feet
Tear Seal	
Bar Seal	
Bar Seal	

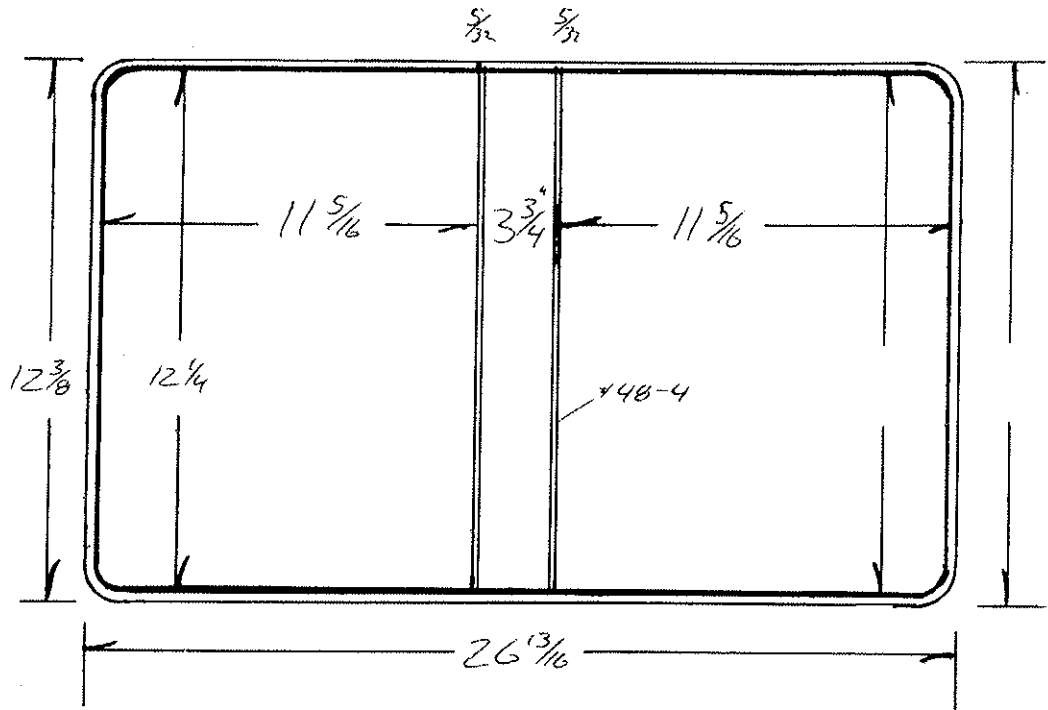

Dwy-B. Pace

Check.

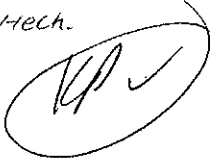

Code	Cutting Specs	Ga.	Pcs	Size	Out	Code	Cutting Specs	Ga.	Pcs	Size	Out
Cover Mat.		$13\frac{1}{8}$	15	$27\frac{5}{8}$	1	Lining Mat.		$13\frac{1}{8}$	15	$27\frac{5}{8}$	1
Cover Mat.		X				Lining Mat.		X			
Vert. Pckt.		X				Horz. Pckt.		X			
Vert. Pckt.		X				Horz. Pckt.		X			
Pocket		X				Pocket		X			
Label Holder		X				Card Holder		X			
Material	COL. $12\frac{1}{2}$ X $27\frac{5}{8}$	8	1			Material		X			
Material	X					Material		X			
Material	X					Material		X			
F.C. Board	$12\frac{5}{32}$ X $11\frac{1}{32}$	120	1			B.C. Board		X			
B.C. Board	$12\frac{5}{32}$ X $11\frac{1}{32}$	120	1			B.B. Board	$12\frac{5}{32}$ X $3\frac{21}{32}$	120	1		
Center Board	X					Board		X			
Board	X					Strip		X			
Cover Pad	X					Strip		X			
						B.B. Pad		X			

Product Code

Style Case 2 ADV. AD VRA

Sheet Size 11 1/4 x 9 5/8 Cap. 2 AD Die No. 4868

Order No. 969896

Plate C-12

Customer

ALABAMA GAS CORP.

9-13

Metal
Total Vinyl
Quantity 50
Date 9-3-91
Type Corners
Radius
Completed

	Gauge	Thick
Tear Seal	.014	1/16
Bar Seal	40-4	5/16
Bar Seal		

	No. of Feet
Tear Seal	
Bar Seal	
Bar Seal	

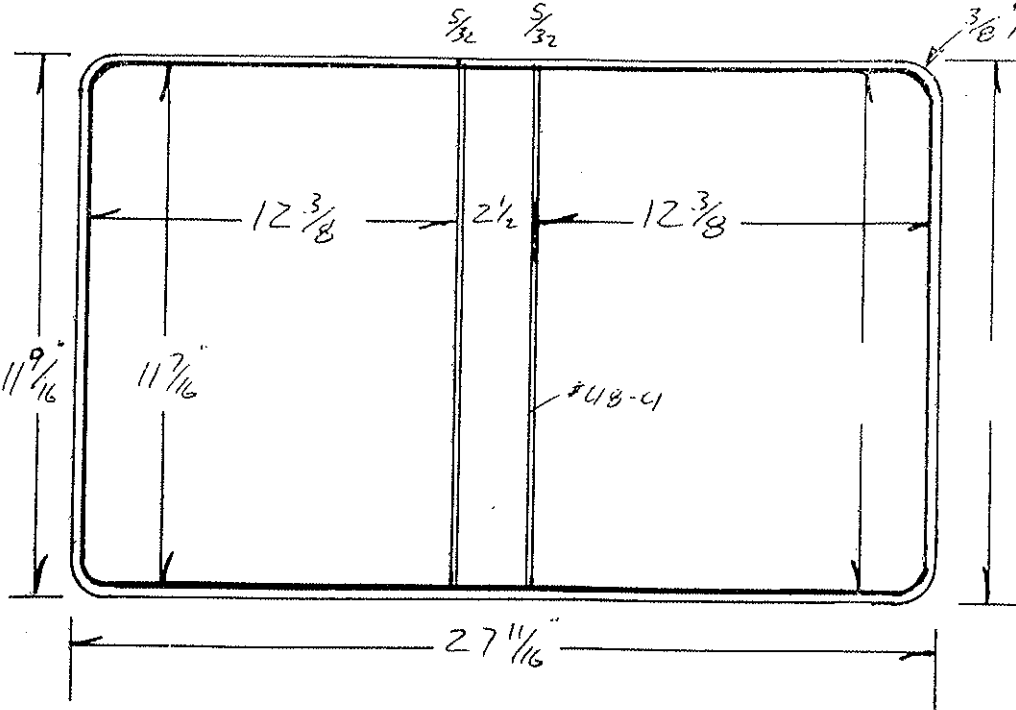

Dwg - B. Price
 Check. *(Signature)*

Code	Ga.	Pcs	Cutting Specs		Code	Ga.	Pcs.	Cutti Specs					
			Size	Out				Size					
Cover Mat.			12 1/4	X	28 1/2		1	Lining Mat.	12 1/4	X	28 1/2		1
Cover Mat				X				Lining Mat.		X			
Vert. Pckt.				X				Horz. Pckt. FL	5 3/8	X	12 7/8		1
Vert. Pckt.				X				Horz. Pckt.		X			
Pocket				X				Pocket		X			
Label Holder				X				Card Holder		X			
Material				X				Material		X			
Material				X				Material		X			
Material				X				Material		X			
F.C. Board			11 1/32	X	12 9/32	120	1	B.C. Board		X			
B.C. Board			11 1/32	X	12 9/32	120	1	B.B. Board	11 1/32	X	2 3/32	120	1
Center Board				X				Board		X			
Board				X				Strip		X			
Cover Pad				X				Strip		X			
								B.B. Pad		X			

Product Code

Style Case VRB

Square M

Sheet Size 11 1/2 x 9 +

Cap. 1" sq. Die No. 5034

Order No. 971870

Plate 0-6-8

Customer

TRAKS RACE PRODUCTS

4-15

Metal
Total Vinyl
Quantity <u>5,000</u>
Date <u>9-1-92</u>
Type Corners
Radius <u>3/16"</u>
Completed

	Gauge	Thick
Tear Seal	<u>.014</u>	<u>1/16</u>
Bar Seal	<u>48-4</u>	<u>7/32"</u>
Bar Seal		

	No. of Feet
Tear Seal	
Bar Seal	
Bar Seal	

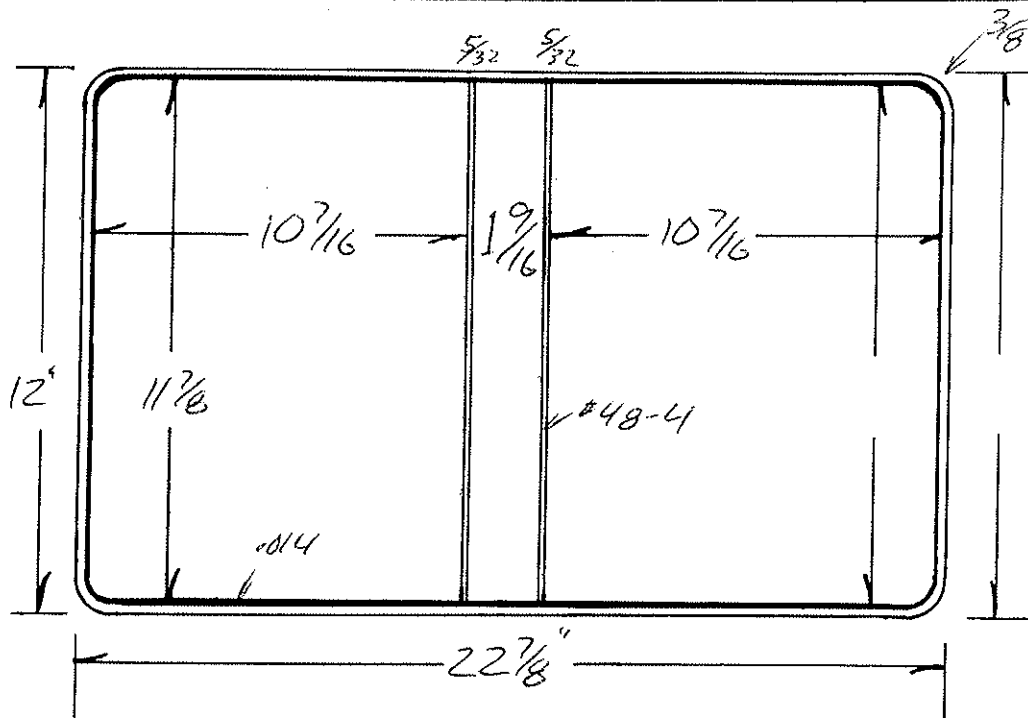

Dwg. B. Pace

CHECK.

Code	Ga.	# PCS	Cutting Specs		Code	Ga.	# Pcs.	Cutting Specs	
			Size	Out				Size	Out
Cover Mat. <u>CLEAR</u>	<u>12 3/4</u>	<u>1</u>	<u>23 5/8</u>		Lining Mat. <u>WHITE</u>	<u>12 3/4</u>	<u>1</u>	<u>23 5/8</u>	
Cover Mat. <u>WHITE</u>	<u>12 3/4</u>	<u>1</u>	<u>23 5/8</u>		Lining Mat.			X	
Vert. Pckt.			X		Horz. Pckt.			X	
Vert. Pckt.			X		Horz. Pckt.			X	
Pocket			X		Pocket			X	
Label Holder			X		Card Holder			X	
Material			X		Material			X	
Material			X		Material			X	
Material			X		Material			X	
F.C. Board	<u>11 25/32</u>	<u>120</u>	<u>10 1/32</u>	<u>1</u>	B.C. Board			X	
B.G. Board	<u>11 25/32</u>	<u>120</u>	<u>10 1/32</u>	<u>1</u>	B.B. Board			X	
Center Board			X		Board	<u>11 25/32</u>	<u>120</u>	<u>15 1/32</u>	<u>1</u>
Board			X		Strip			X	
Cover Pad			X		Strip			X	
					B.B. Pad			X	

Product Code

Style Case *VRB A.D.N.B* STOCK-INTERGR

Sheet Size *12 x 10 1/4* Cap. *3 A.D.* Die No. *5068* Order No. *972370* Plate *D-7-*

COATS & CLARK INC.

G-1

Customer

Metal
Total Vinyl
Quantity <i>50</i>
Date <i>5-21-92</i>
Type Corners
Radius <i>3/8</i>
Completed

	Gauge	Thick
Tear Seal	<i>.014</i>	<i>1/16</i>
Bar Seal	<i>48-4</i>	<i>5/32</i>
Bar Seal		

	No. of Feet
Tear Seal	
Bar Seal	
Bar Seal	

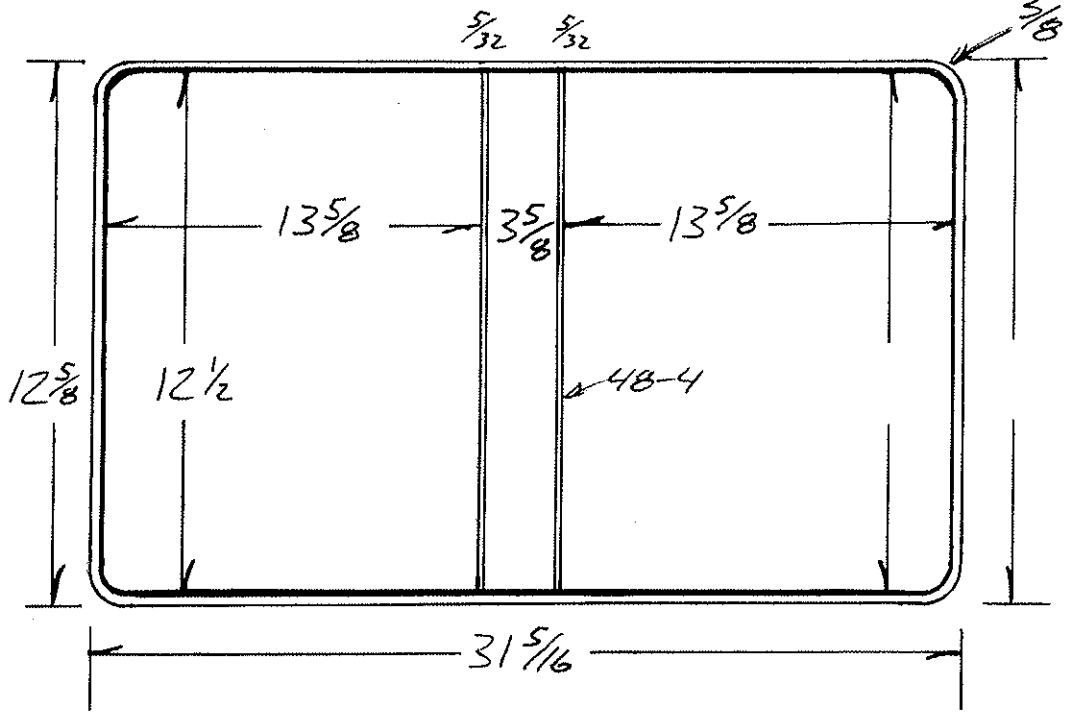

Dwg - B. Pace

Check -

Code		Cutting Specs		Code		Cutting Specs			
		Ga.	# PCS	Size	Out	Ga.	# Pcs.	Size	Out
Cover Mat.	<i>13 3/8 x 32 1/8</i>	<i>14</i>	<i>1</i>			Lining Mat.	<i>13 3/8 x 32 1/8</i>	<i>14</i>	<i>1</i>
Cover Mat.	X					Lining Mat.	X		
Vert. Pckt.	X					Horz. Pckt.	<i>5 3/8 x 32 1/8</i>	<i>1</i>	
Vert. Pckt.	X					Horz. Pckt.	X		
Pocket	X					Pocket	X		
Label Holder	X					Card Holder	X		
Material	<i>Full C.O.L. 12 3/4 x 32 1/8</i>					Material	X		
Material	<i>Ex COL 12 3/4 x 18 1/2</i>					Material	X		
Material	X					Material	X		
F.C. Board	<i>12 13/32 x 13 17/32</i>	<i>120</i>	<i>1</i>			B.C. Board	X		
B.C. Board	<i>12 13/32 x 13 17/32</i>	<i>120</i>	<i>1</i>			B.B. Board	<i>12 13/32 x 3 17/32</i>	<i>120</i>	<i>1</i>
Center Board	X					Board	X		
Board	X					Strip	X		
Cover Pad	X					Strip	X		
						B.B. Pad	X		

Product Code

Stock #7

Style Case Metric D-ring

Sheet Size 11 3/4 x 8 3/4 Cap. 2 1/2 Die No. 5144 Order No. 973102 Plate 9-4

Customer Camco Products & Service Co D10-6

Metal
Total Vinyl
Quantity 750
Date 8-12-98
Type Corners 3/8
Radius 3/8
Completed

Gauge	Thick
Bar Seal 484	1/16
Bar Seal 484	5/32
Bar Seal	

No. of Feet
Bar Seal
Bar Seal
Bar Seal

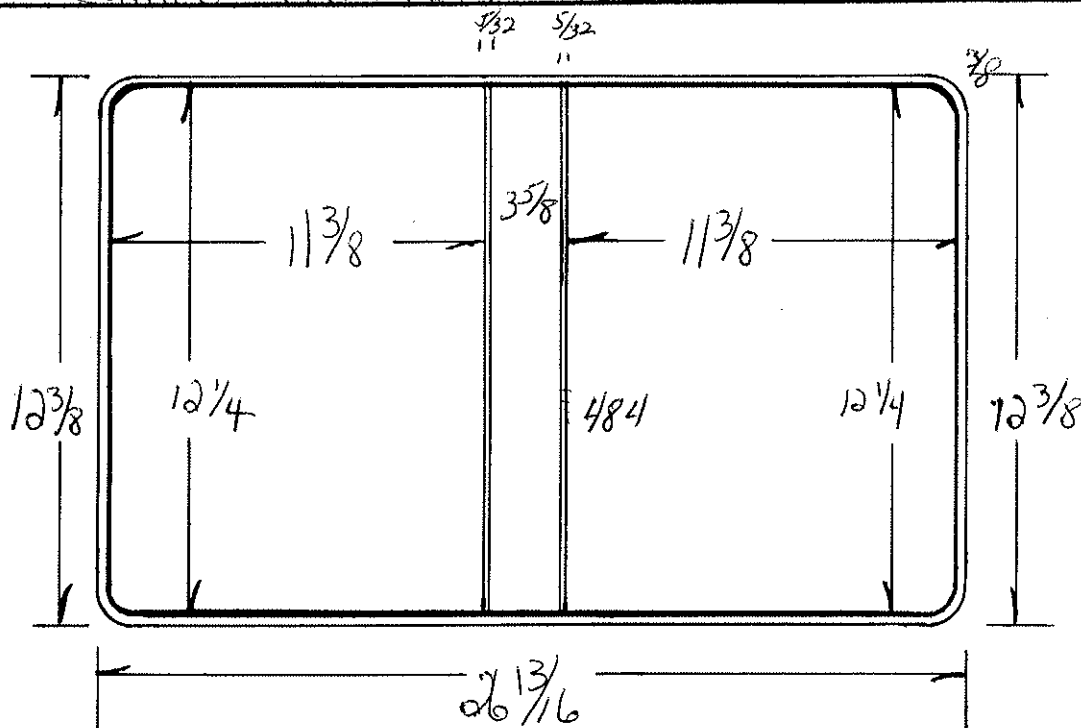

Dwg. Jim

Code		Cutting Specs		Code		Cutting Specs	
Code	Qty	Ga.	PCS	Size	Qty	Ga.	PCS
Cover Mat.	13		1	27 1/2	Lining Mat.	13	1
Cover Mat.	X				Lining Mat.	X	
Vert. Pckt.	X				Horz. Pckt.	5 3/8 X 27 1/2	
Vert. Pckt.	X				Horz. Pckt.	X	
COL	12 1/2		1	16 1/4	Pocket	X	
Label Holder	X				Card Holder	X	
Material	X				Material	X	
Material	X				Material	X	
Material	X				Material	X	
F.C. Board	12 3/16 X 11 5/16	100	1		B.C. Board	12 5/32 X 11 9/32	100
B.C. Board	12 3/16 X 11 5/16	100	1		F.B. Board	12 5/32 X 11 9/32	100
Center Board	12 3/16 X 3 17/32	100	1		Board	12 5/32 X 3 17/32	100
Board	X				Strip	X	
Cover Pad	X				Strip	X	
					B.B. Pad	X	

Product Code

Style Case VRB (D. Ring)

Actual Closed

Sheet Size 11 1/4 x 14 1/4 Cap. 1"

Die No. 5229

Order No. 974003

Plate D14-M

Customer

Motivational Marketing

12-21

Metal
Total Vinyl
Quantity <u>1000</u>
Date <u>12-2-92</u>
Type Corners <u>Rnd</u>
Radius <u>1/4</u>
Completed

	Gauge	Thick
Tear Seal	<u>.014</u>	<u>1/16</u>
Bar Seal	<u>103</u>	<u>1/16</u>
Bar Seal		

	No. of Feet
Tear Seal	
Bar Seal	
Bar Seal	

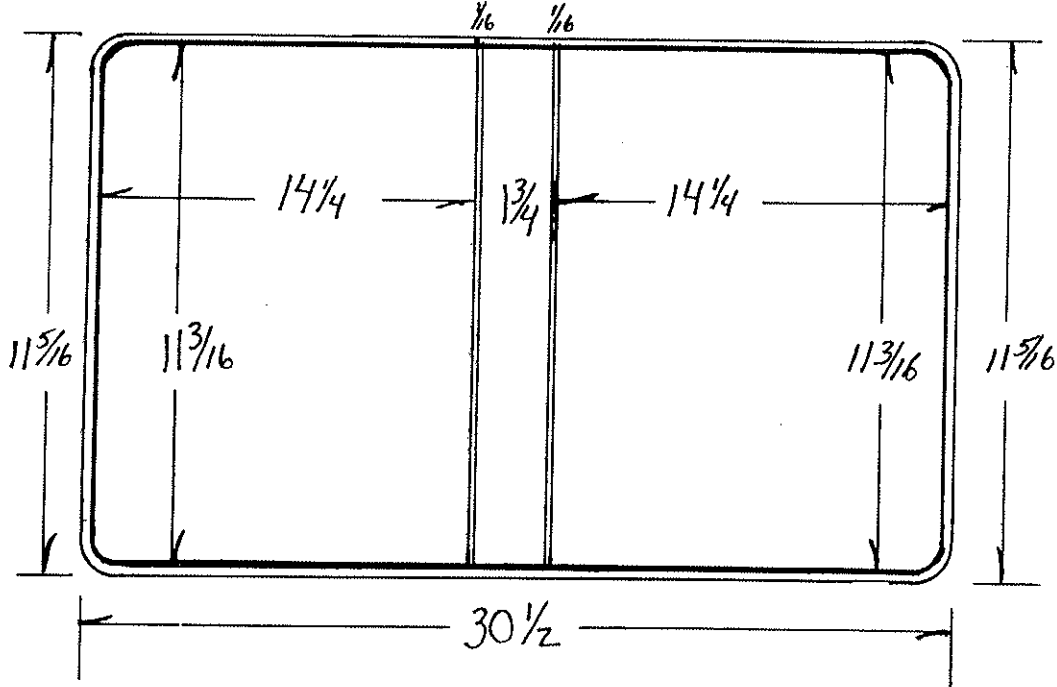

Tim.

Code	Ga.	# PCS	Cutting Specs		Code	Ga.	# PCS	Cutting Specs	
			Size	Out				Size	Out
Cover Mat.			<u>12 1/8</u>	<u>X 31 1/4</u>				<u>1</u>	
Cover Mat.				X	Lining Mat.			<u>12 1/8</u>	<u>X 31 1/4</u>
Vert. Pckt.				X	Lining Mat.				X
Vert. Rckt.				X	Horz. Pckt.				X
Pocket				X	Horz. Pckt.				X
Label Holder				X	Pocket				X
Material				X	Card Holder				X
Material				X	Material				X
Material				X	Material				X
F.C. Board			<u>11 3/32</u>	<u>X 14 5/32</u>	B.C. Board			<u>11 1/8</u>	<u>X 14 3/16</u>
B.C. Board			<u>11 3/32</u>	<u>X 14 5/32</u>	B.B. Board			<u>11 1/8</u>	<u>X 12 1/32</u>
Center Board			<u>11 3/32</u>	<u>X 1 2 1/32</u>	Board			<u>11 1/8</u>	<u>X 14 3/16</u>
Board				X	Strip				X
Cover Pad				X	Strip				X
					B.B. Pad				X

DIE #	5299	STYLE CASE	VRB	LOCATION	D17-7
SHEET SIZE	11 ¹ / ₁₆ X 9 ¹ / ₄ + ¹ / ₂	CAP.	1"	ORDER NO.	974606
CUSTOMER	FO-Jo Photo Finishing			DUE DATE	

QUANTITY	1000
DATE	3-2-93

RADIUS	3/8
COMPLETED	

TEAR SEAL	.012
BAR SEAL	484

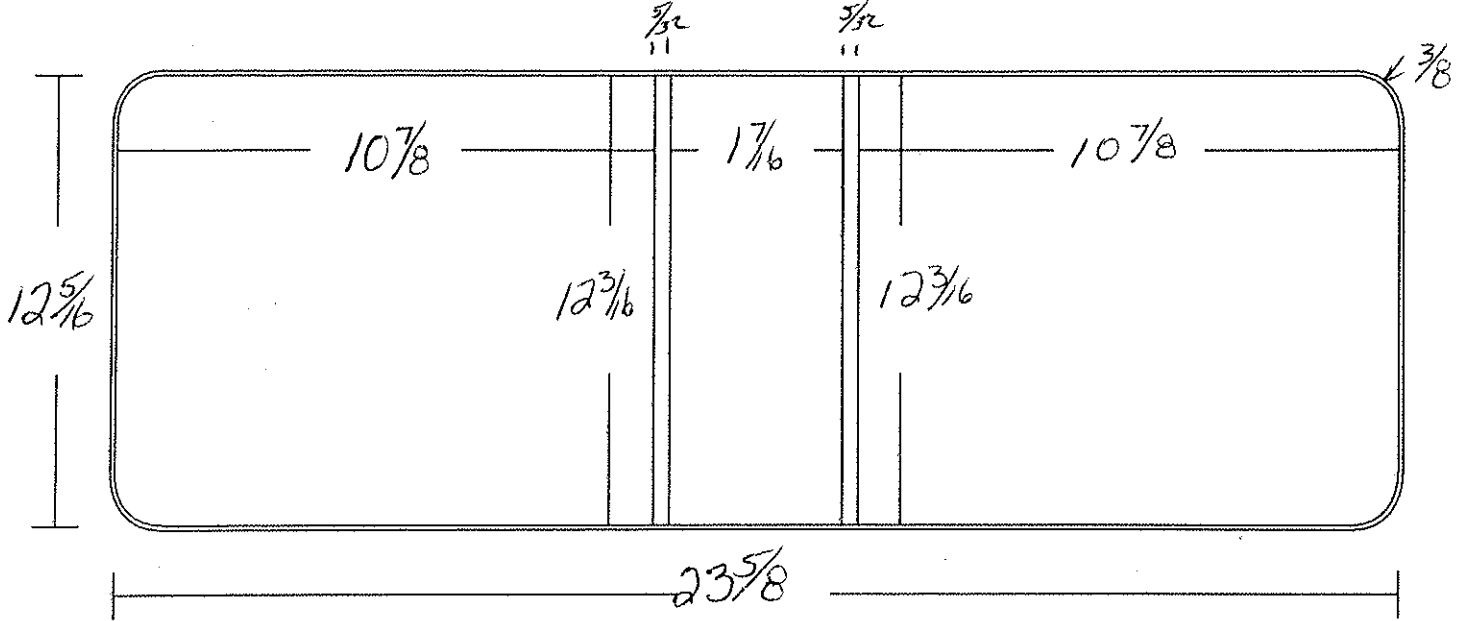

Jim

MATERIAL

	CODE		GA	PCS		CODE		GA	PCS
COVER MATL		13 ¹ / ₁₆ X 24 ³ / ₈		1	LINING		13 ¹ / ₁₆ X 24 ³ / ₈		1
COVER MATL	Padded	13 ⁵ / ₁₆ X 24 ⁵ / ₈			LINING		X		
VERT PKT		X			HORZ PKT		X		
VERT PKT		X			HORZ PKT		X		
CARD HOLDER		X			DIAGONAL PKT		X		
COL		X			LABEL HOLDER		X		
EX. COL		X			CUSSETT		X		
		X			REINF.		X		
		X					X		

PRINTS

FRONT COVER	X	BACK BONE	X	BACK COVER	X
-------------	---	-----------	---	------------	---

BOARDS

	CODE		PT	PCS		CODE		PT	PCS
F.C. BOARD		12 ³ / ₃₂ X 10 ²⁵ / ₃₂	120	1	F.C. BOARD		12 ¹ / ₈ X 10 ¹³ / ₁₆	100	1
B.B. BOARD		12 ³ / ₃₂ X 1 ¹ / ₃₂	120	1	B.B. BOARD		12 ¹ / ₈ X 1 ¹ / ₃₂	100	1
B.C. BOARD		12 ³ / ₃₂ X 10 ²⁵ / ₃₂	120	1	B.C. BOARD		12 ¹ / ₈ X 10 ¹³ / ₁₆	100	1
B. UP STRIP	Padded Board	X					X		
Die cut size		13 ³ / ₃₂ X 27 ¹ / ₃₂					X		

Stock A4

DIE # 5414		STYLE CASE VINYL RING BINDER		LOCATION E6-5	
SHEET SIZE 11 3/4 X 8 1/4 + 1/2		CAP. 1/2		ORDER # 976040	
CUSTOMER IMTECH				DUE DATE	
QUANTITY	100	RADIUS	3/8	TEAR SEAL	.012
DATE	8-31-93	COMPLETED		BAR SEAL	484

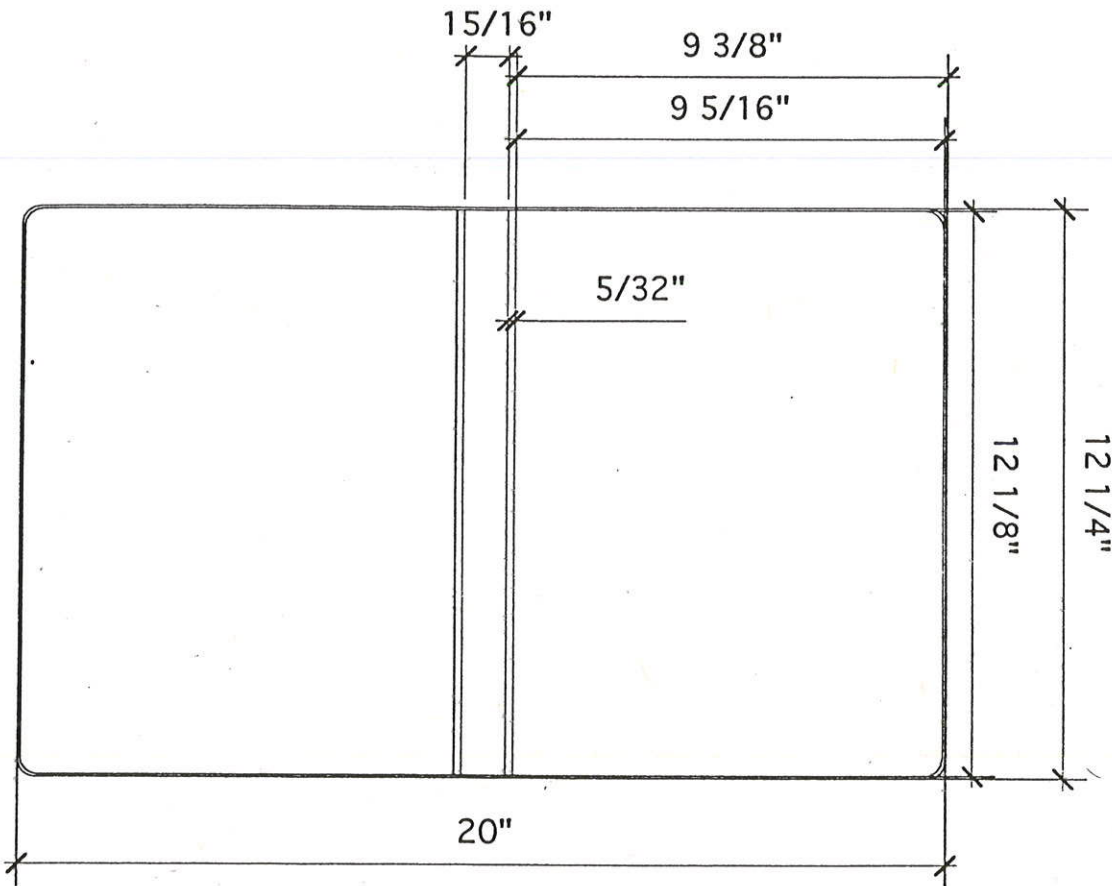

MATERIAL SPECS

GA PCS

GA PCS

COVER MATL	13X20 3/4	1	LINING	13X20 3/4	1
COVER MATL			LINING		
VERT PKT			HORZ PKT	5 3/8 X 20 3/4	1
VERT PKT			HORZPKT		
CARD HOLDER			DIAGONAL PKT		
COL			LABEL HOLDER		
EX COL			GUSSET		
			REINF		

BOARD SPECS

F.C. BOARD	12 1/16 X 9 1/4	100	1	F.C. BOARD		
B.B. BOARD	12 1/16 X 27/32	100	1	B.B. BOARD		
B.C. BOARD	12 1/16 X 9 1/4	100	1	B.C. BOARD		
BU STRIP						

DIE #	5563	STYLE CASE	NAT EDGE A-4 BINDER	LOCATION	E9-1
SHEET SIZE	11 3/4 X 8 3/4	CAP.	1	ORDER #	977940
CUSTOMER	COLAD GROUP INC.			DUE DATE	
QUANTITY		RADIUS	3/8	TEAR SEAL	.012
DATE		COMPLETED		BAR SEAL	484

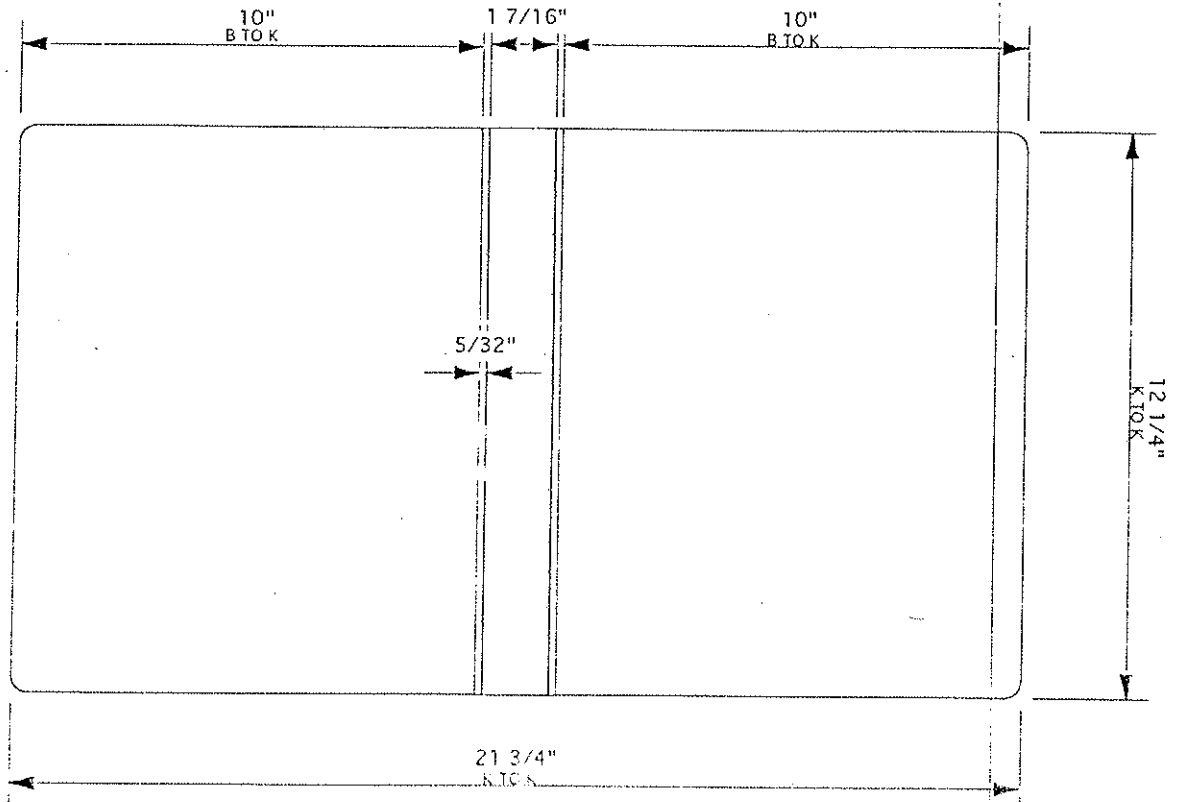

MATERIAL SPECS		GA	PCS	GA		PCS
COVER MATL	13 X 22 1/2	1	LINING	13 X 22 1/2	1	
COVER MATL			LINING			
VERT PKT			HORZ PKT			
VERT PKT			HORZPKT			
CARD HOLDER			DIAGONAL PKT			
COL			LABEL HOLDER			
EX COL			GUSSETT			
			REINF			

BOARD SPECS						
F.C. BOARD	12 1/8 X 9 29/32	1	F.C. BOARD			
B.B. BOARD	12 1/8 X 1 11/32	1	B.B. BOARD			
B.C. BOARD	12 1/8 X 9 29/32	1	B.C. BOARD			
BU STRIP						

DIE # 5644		STYLE CASE SCREW POST BINDER		LOCATION E13-4	
SHEET SIZE 12 X 9 1/2		CAP. 3 1/2		ORDER # 979086	
CUSTOMER HE HARRIS				DUE DATE 9-15	
QUANTITY	500	RADIUS	3/8	TEAR SEAL	.014
DATE		COMPLETED		BAR SEAL	483

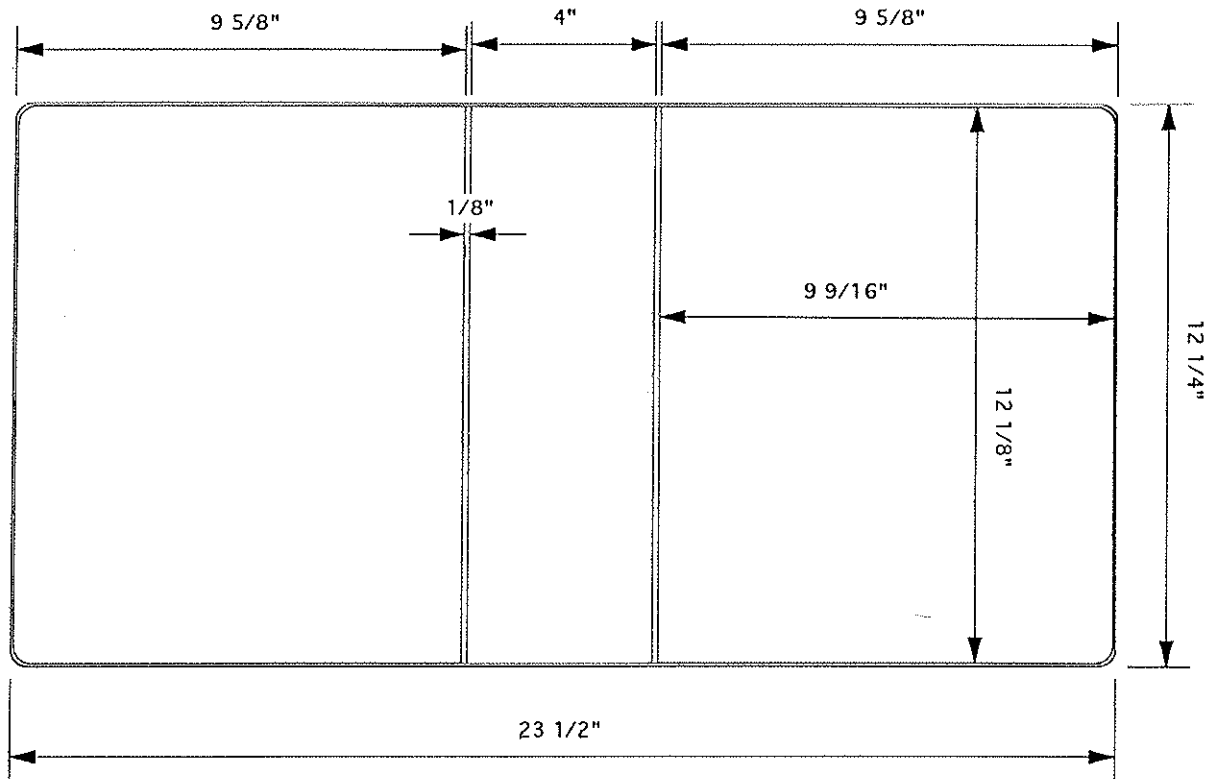

MATERIAL SPECS

GA PCS

GA PC

COVER MATL	13 X 24 1/4	1	LINING	13 X 24 1/4	1
COVER MATL			LINING		
VERT PKT			HORZ PKT		
VERT PKT			HORZPKT		
CARD HOLDER			DIAGONAL PKT		
COL			LABEL HOLDER	2 1/8 X 1 3/4	
EX COL			GUSSETT		
			REINF		

BOARD SPECS

F.C. BOARD	12 1/32 X 9 15/32	120	1	F.C. BOARD	
B.B. BOARD	12 1/32 X 3 29/32	120	1	B.B. BOARD	
B.C. BOARD	12 1/32 X 9 15/32	120	1	B.C. BOARD	
BU STRIP					

DIE # 5674		STYLE CASE VRB		LOCATION E-15-2	
SHEET SIZE 11 1/4 X 9 5/8		CAP. 1 1/2		ORDER # 979093	
CUSTOMER SMITH CONTAINER CORP.				DUE DATE 10-18-94	
QUANTITY	50	RADIUS	3/8	TEAR SEAL	.014
DATE	9-29-94	COMPLETED		BAR SEAL	48-4

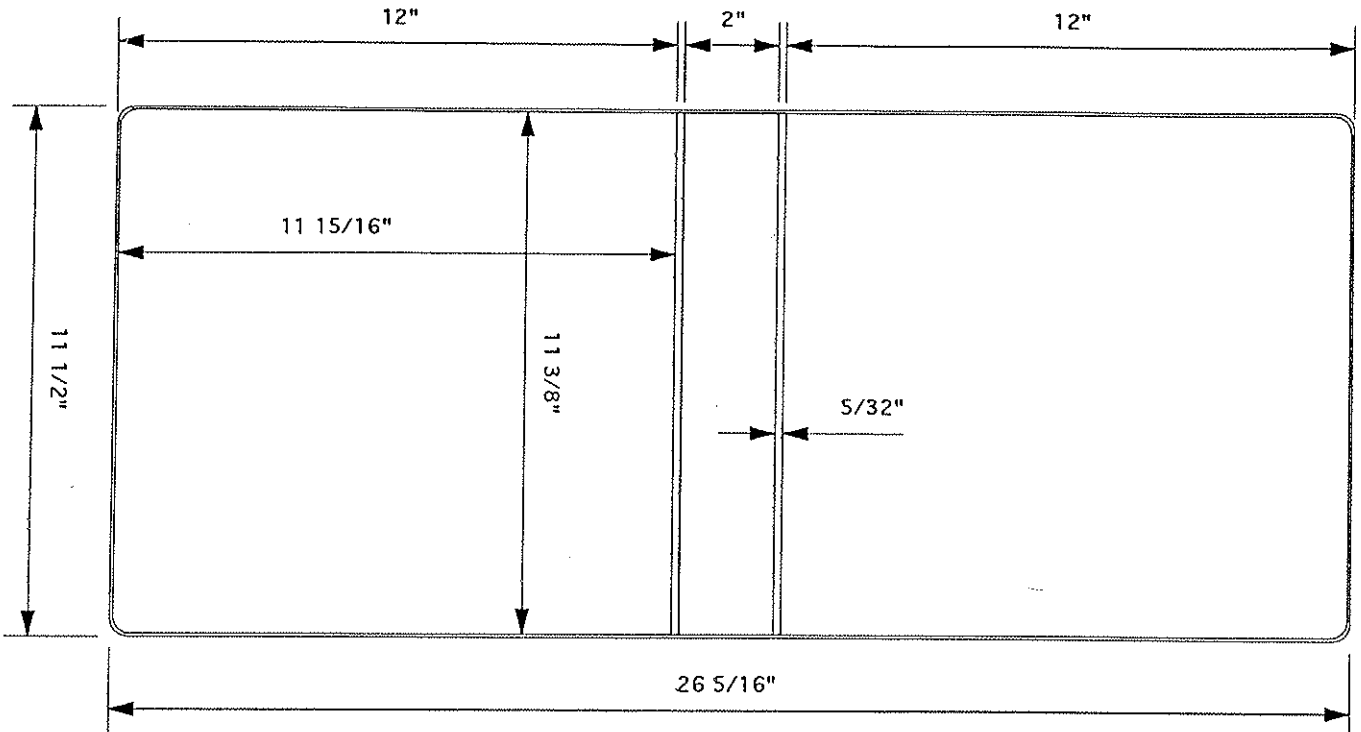

MATERIAL SPECS

GA PCS

GA PCS

COVER MATL	12 1/4 X 27	1	LINING	12 1/4 X 27	1
COVER MATL			LINING		
VERT PKT			HORZ PKT	5 3/8 X 12 5/8	1
VERT PKT			HORZPKT		
CARD HOLDER			DIAGONAL PKT		
COL			LABEL HOLDER		
EX COL			GUSSETT		
			REINF		

BOARD SPECS

GA PCS

F.C. BOARD	11 5/15 X 11 7/8	100	1	F.C. BOARD		
B.B. BOARD	11 5/16 X 1 29/32	100	1	B.B. BOARD		
B.C. BOARD	11 5/16 X 11 7/8	100	1	B.C. BOARD		
BU STRIP						

DIE #	5974	METAL	ANGLE D	RADIUS	3/8"
ORDER #	983436	CUSTOMER	HANN & DEPALMER	TEAR SEAL	.012
SHEET SIZE	11 X 11	STYLE CASE	VINYL RING BINDER	BAR SEAL	253
CAP.	3"	DUE DATE	12-29-95	COMPLETED	
LOCATION	F-5-7	QUANTITY	750	DATE	12-18-95

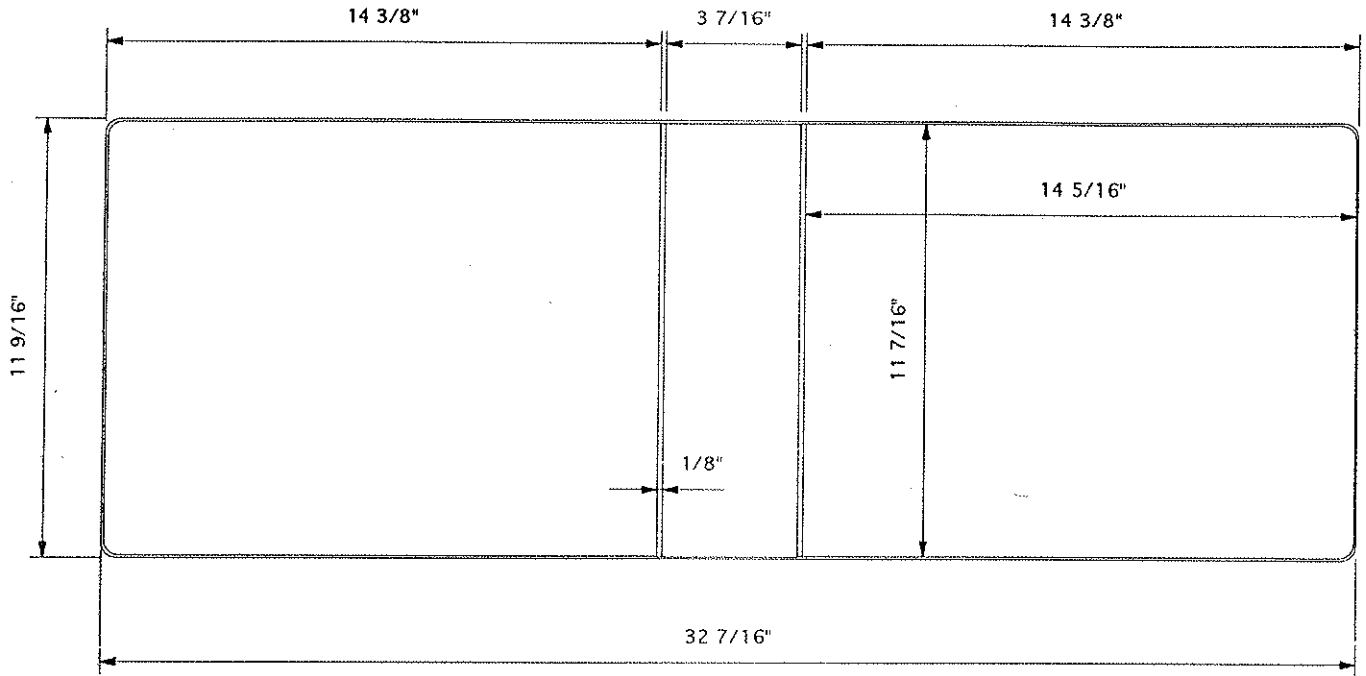

MATERIAL SPECS		GAUGE		MATERIAL SPECS		GAUGE	
COVER MAT.	12 5/16 X 33 1/4		1	LINING MAT.	12 5/16 X 33 1/4		
COVER MAT.				LINING MAT.			
DIE CUT				HORZ. PKT.	5 3/8 X 33 1/4		
COL	11 11/16 X 18 3/4		1	VERT. PKT.			
LABEL HOLDER				DIE CUT			
GUSSET				REINF.			

BOARD SPECS		GAUGE		BOARD SPECS		GAUGE	
F.C. BOARD	11 11/32 X 14 7/32	120	1	F.C. INSERT			
B.B. BOARD	11 11/32 X 3 11/32	120	1	B.B. INSERT			
B.C. BOARD	11 11/32 X 14 7/32	120	1	B.C. INSERT			
B.U. STRIP				DIE CUT			
DIE CUT				DIE CUT			

Per Customer Specs

DIE #	6027	METAL	NB STR D	RADIUS	3/8
ORDER #	72966	CUSTOMER	YUBA	TEAR SEAL	.014
SHEET SIZE	11 3/4 X 8 3/4	STYLE CASE	VINYL RING BINDER	BAR SEAL	253
CAP.	1 1/2"	DUE DATE	4-15-96	COMPLETED	
LOCATION	G-8-7	QUANTITY	50	DATE	3-22-96

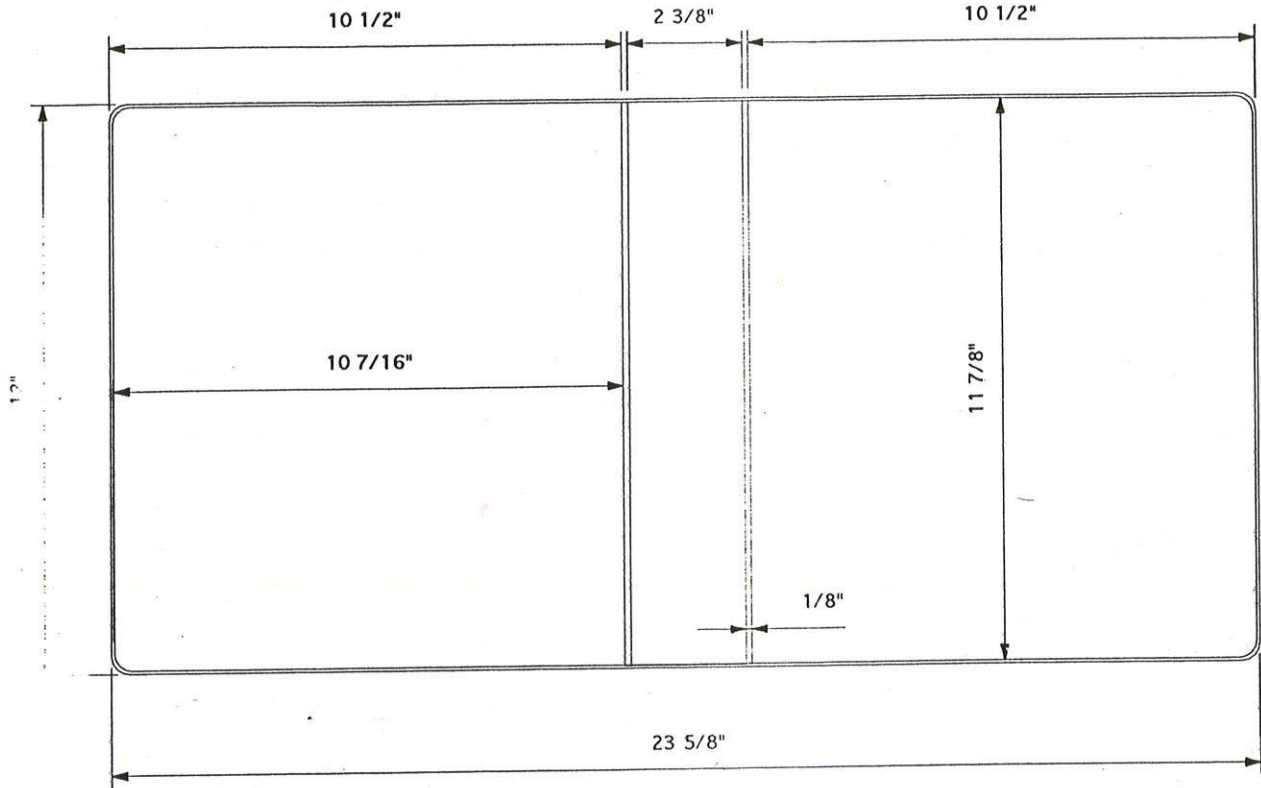

MATERIAL SPECS		GAUGE		PCS.		MATERIAL SPECS		GAUGE		PCS.	
COVER MAT.	12 3/4 X 25 1/8			1		LINING MAT.	12 3/4 X 25 1/8			1	
COVER MAT.						LINING MAT.					
DIE CUT						HORZ. PKT.	5 3/8 X 25 1/8			1	
COL	12 1/4 X 11 1/8			1		VERT. PKT.					
LABEL HOLDER						DIE CUT					
GUSSET						REINF.					

BOARD SPECS		GAUGE		PCS.		BOARD SPECS		GAUGE		PCS.	
F.C. BOARD	11 25/32 X 10 11/32	120		1		F.C. BOARD					
B.B. BOARD	11 25/32 X 2 9/32	120		1		B.B. BOARD					
B.C. BOARD	11 25/32 X 10 11/32	120		1		B.C. BOARD					
B.U. STRIP						DIE CUT					
DIE CUT						DIE CUT					

Stock #4

DIE #	6179	METAL	NB ROUNDING	RADIUS	3/8"
ORDER #	986235	CUSTOMER	LECTRA SYSTEMS	TEAR SEAL	.014
SHEET SIZE	11 3/4 X 8 3/4	STYLE CASE	VRB	BAR SEAL	253
CAP.	3/4"	DUE DATE	1-21-96	COMPLETED	
LOCATION	G-1-4	QUANTITY	2000	DATE	1-3-97

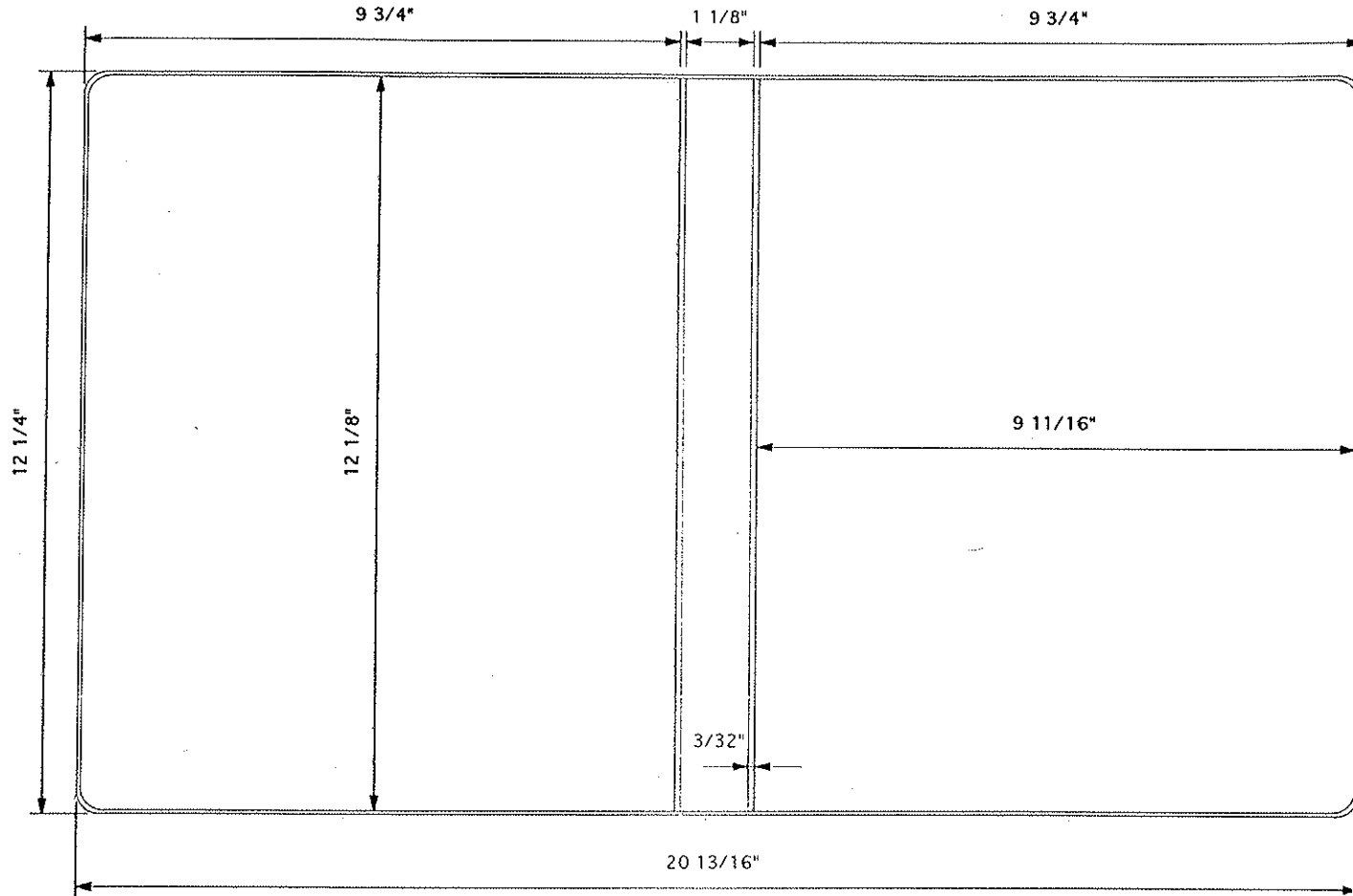

MATERIAL SPECS		GAUGE		PCS.		MATERIAL SPECS		GAUGE	
COVER MAT.	13 X 21 1/2			1	LINING MAT.	13 X 21 1/2			
COVER MAT.					LINING MAT.				
DIE CUT					HORZ. PKT.	5 3/8 X 10 1/4			
COL					VERT. PKT.				
LABEL HOLDER					DIE CUT				
GUSSET					REINF.				

BOARD SPECS		GAUGE		PCS.		BOARD SPECS		GAUGE	
F.C. BOARD	12 1/16 X 9 5/8	100	1	F.C. BOARD	Padded - FC-BB-BC 6179-A				
B.B. BOARD	12 1/16 X 1 1/32	100	1	B.B. BOARD	14 9/16 X 20 1/16				
B.C. BOARD	12 1/16 X 9 5/8	100	1	B.C. BOARD					
FLAP BD.				DIE CUT					
BOARD				DIE CUT					

DIE #	6245	METAL	HEAVY DUTY NB RR	RADIUS	3/8"
ORDER #	987113	CUSTOMER	TPS	TEAR SEAL	.014
SHEET SIZE	11 1/2 X 9 1/2	STYLE CASE	VINYL RING BINDER	BAR SEAL	253
CAP.	1 1/2"	DUE DATE	5-21-97	COMPLETED	
LOCATION	H-4-7	QUANTITY	3000	DATE	5-8-97

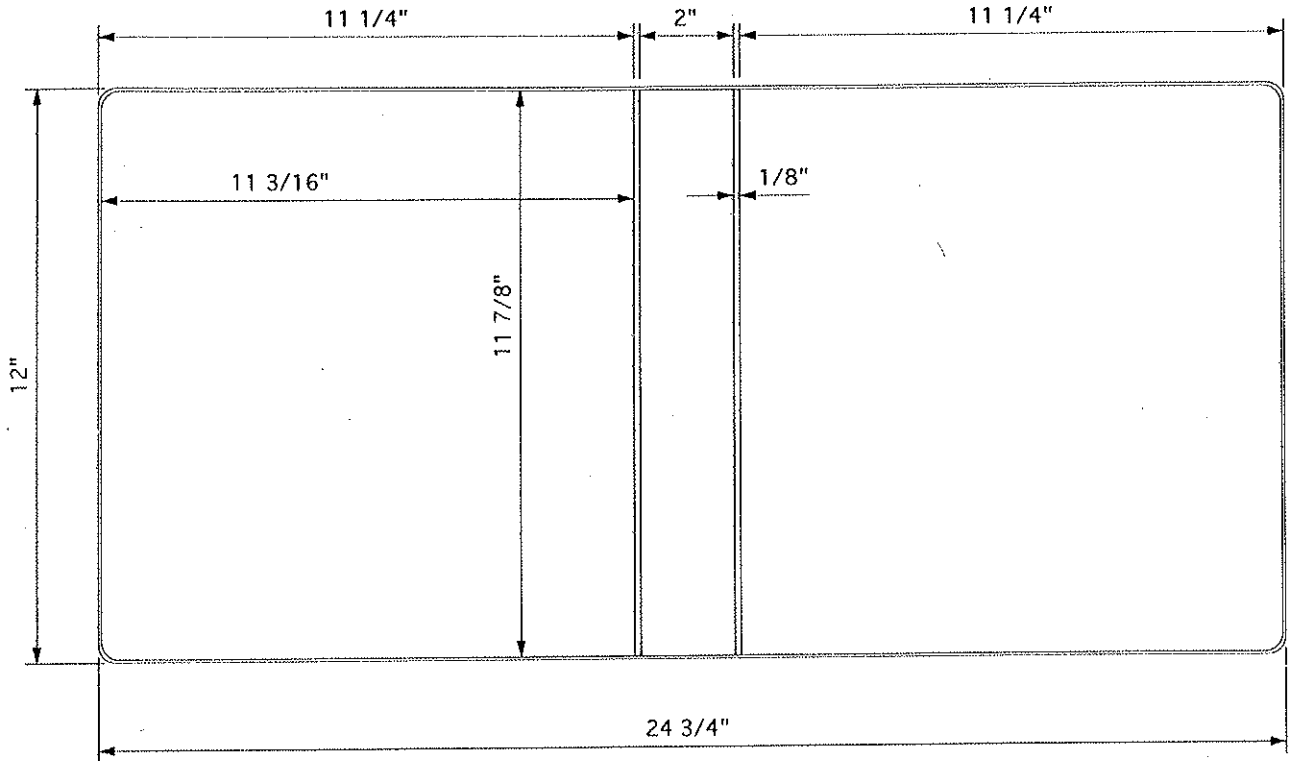

MATERIAL SPECS		GAUGE		MATERIAL SPECS		GAUGE	
COVER MAT.	12 3/4 X 25 1/2		1	LINING MAT.	12 3/4 X 25 1/2		
COVER MAT.				LINING MAT.			
DIE CUT				HORZ. PKT.			
COL				VERT. PKT.			
LABEL HOLDER				DIE CUT			
GUSSET				REINF.			

BOARD SPECS		GAUGE		BOARD SPECS		GAUGE	
F.C. BOARD	11 13/16 X 11 1/8	120	1	F.C. BOARD			
B.B. BOARD	11 13/16 X 1 29/32	120	1	B.B. BOARD			
B.C. BOARD	11 13/16 X 11 1/8	120	1	B.C. BOARD			
FLAP BD.				DIE CUT			
BOARD				DIE CUT			

DIE #	6368	METAL	3" ANGLE D	RADIUS	3/8"
ORDER #	988523	CUSTOMER	SAYERS PRINTING	TEAR SEAL	.014
SHEET SIZE	11 3/4 X 10 3/4	STYLE CASE	VINYL RING BINDER	BAR SEAL	48-4
CAP.	3"	DUE DATE	11-21-97	COMPLETED	
LOCATION	1-7-9	QUANTITY	950	DATE	11-6-97

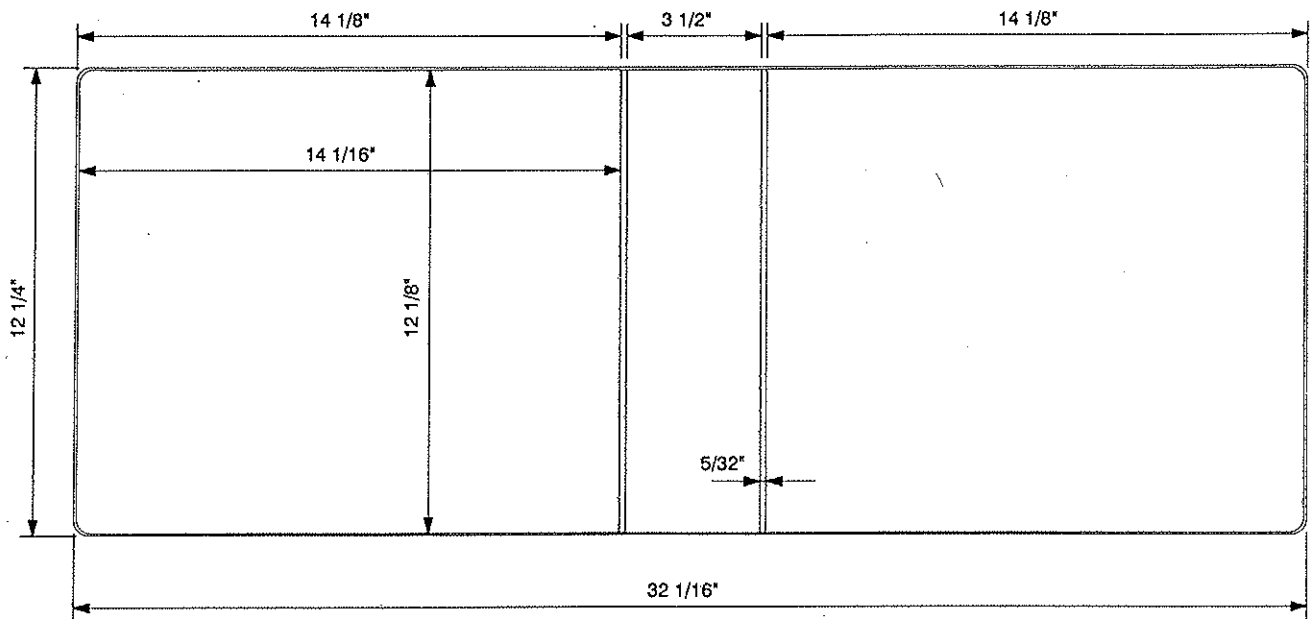

MATERIAL SPECS		GAUGE		PCS.		MATERIAL SPECS		GAUGE	
COVER MAT.	13 X 32 7/8			1		LINING MAT.	13 X 32 7/8		
COVER MAT.						LINING MAT.			
DIE CUT						HORZ. PKT.	5 3/8 X 32 7/8		
COL	12 7/16 X 32 7/8			1		VERT. PKT.			
LABEL HOLDER						DIE CUT			
GUSSET						REINF.			

BOARD SPECS		GAUGE		PCS.		BOARD SPECS		GAUGE	
F.C. BOARD	12 1/16 X 14	120	1			F.C. BOARD			
B.B. BOARD	12 1/16 X 3 13/32	120	1			B.B. BOARD			
B.C. BOARD	12 1/16 X 14	120	1			B.C. BOARD			
FLAP BD.						DIE CUT			
BOARD						DIE CUT			

DIE #	6381-A	METAL	STR D (BENSON)	RADIUS	3/8"
ORDER #		CUSTOMER	PRINT PROMOTIONS	TEAR SEAL	.014
SHEET SIZE	11 1/2 X 9 3/4	STYLE CASE	VRB 2UP FIAB	BAR SEAL	254
CAP.	1 1/2"	DUE DATE		COMPLETED	
LOCATION		QUANTITY	25,000	DATE	12-3-97

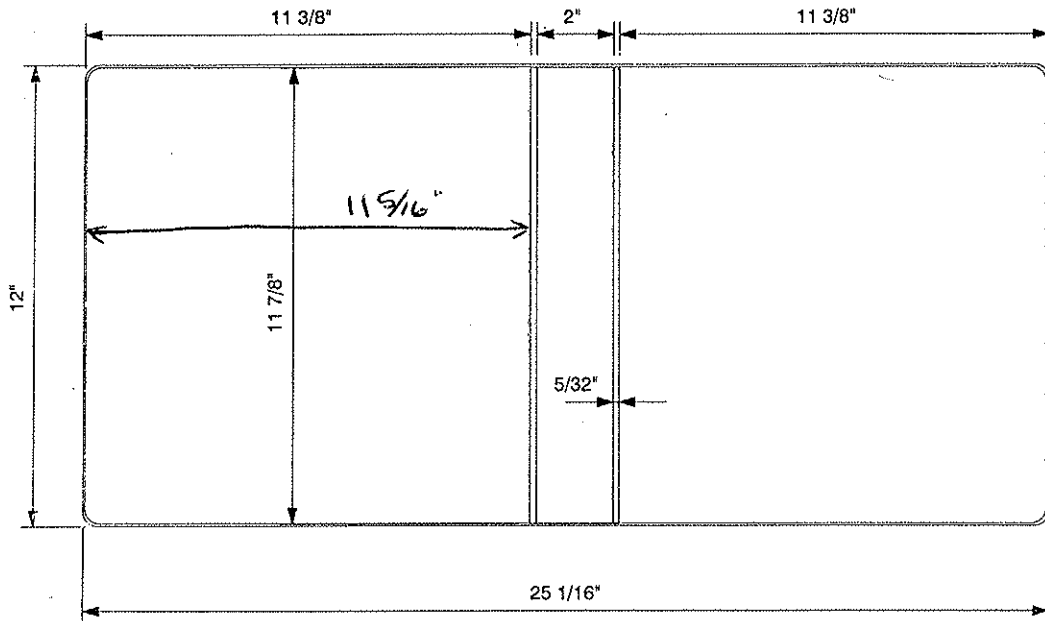

MATERIAL SPECS		GAUGE PCS.		MATERIAL SPECS		GAUGE P	
COVER MAT.	13 X 26 1/8	1		LINING MAT.	13 X 26 1/8		
HEAL SEAL FOAM	13 X 26 1/8	1		LINING MAT.			
LABEL HOLDER				HORZ. PKT.	4 7/8 x 26 1/8		
COL				HORZ. PKT.			
EX COL NO TRIM				ONE SIDED			
EX COL				ONE SIDED			

NORMAL 1/16" TOL		PCS.		EXPANDED MATERIAL BOARD TOL. (3/32")		P	
F.C. BOARD	11 13/16 x 11 1/4	1		F.C. BOARD	11 25/32 X 11 7/32		
B.B. BOARD	11 3/16 x 1 29/32	1		B.B. BOARD	11 25/32 X 1 29/32		
B.C. BOARD	11 3/16 x 11 1/4	1		B.C. BOARD	11 25/32 X 11 7/32		
FLAP BD.				DIE CUT			

DIE #	6480	METAL	LOC N/B	RADIUS	3/8"
ORDER #	77834	CUSTOMER	SCREAMING COLOR CORP	TEAR SEAL	.012
SHEET SIZE	11.75 X 9	STYLE CASE	VINYL RING BINDER	BAR SEAL	48-4
CAP.	1/2"	DUE DATE	4-13-98	COMPLETED	
LOCATION	F-10-1	QUANTITY	1	DATE	4-13-98

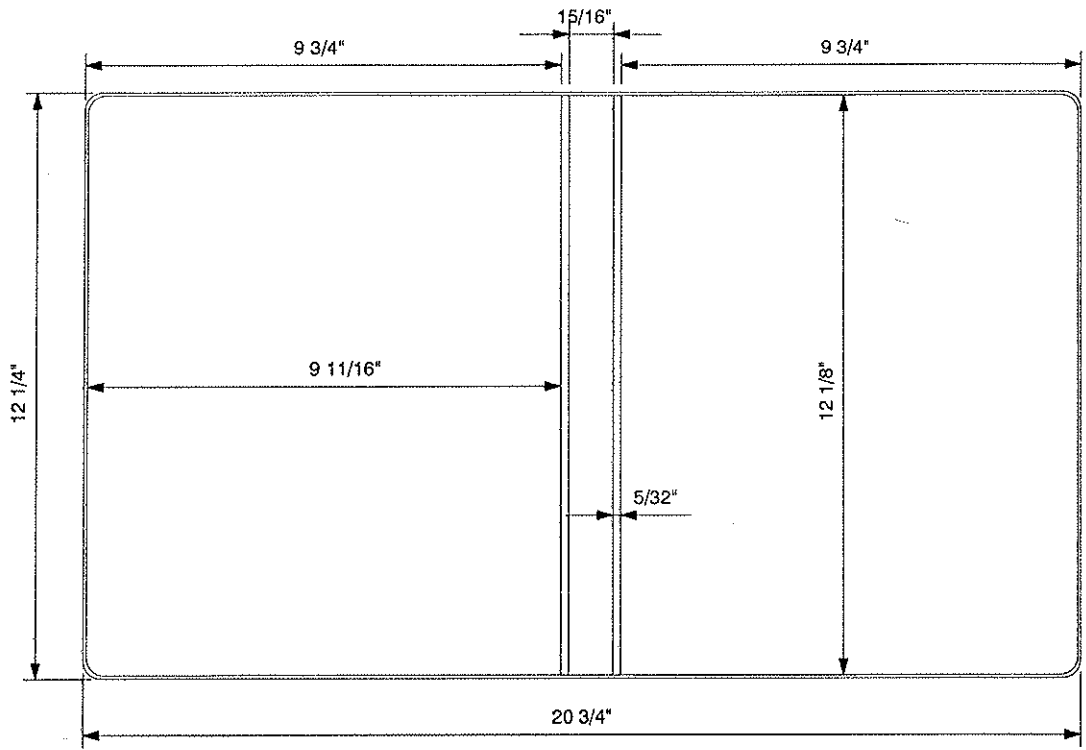

MATERIAL SPECS		GAUGE	PCS.	MATERIAL SPECS		GAUGE	PCS.				
COVER MAT.	13 X 21 1/2		1	LINING MAT.	13 X 21 1/2		1				
COVER MAT.				LINING MAT.							
DIE CUT				HORZ. PKT.	4 7/8 X 21 1/2		1				
COL	12 1/2 X 10 1/4		1	VERT. PKT.							
LABEL HOLDER				DIE CUT							
GUSSET				REINF.							
BOARD SPECS		5/16" R. CORNERS		GAUGE	PCS.	BOARD SPECS		5/16" R. CORNERS		GAUGE	PCS.
F.C. BOARD	12 1/16 X 9 5/8	100	1	F.C. BOARD							
B.B. BOARD	12 1/16 X 27/32	100	1	B.B. BOARD							
B.C. BOARD	12 1/16 X 9 5/8	100	1	B.C. BOARD							
FLAP BD.				DIE CUT							
BOARD				DIE CUT							

DIE #	6621	METAL	NBRR	RADIUS	3/8"
ORDER #	195750	CUSTOMER	PBM GRAPHICS	TEAR SEAL	.012
SHEET SIZE	12 X 9.25	STYLE CASE	VRB	BAR SEAL	253
CAP.	1"	DUE DATE	1-29-99	COMPLETED	
LOCATION	1-9-2	QUANTITY	7500	DATE	1-11-99

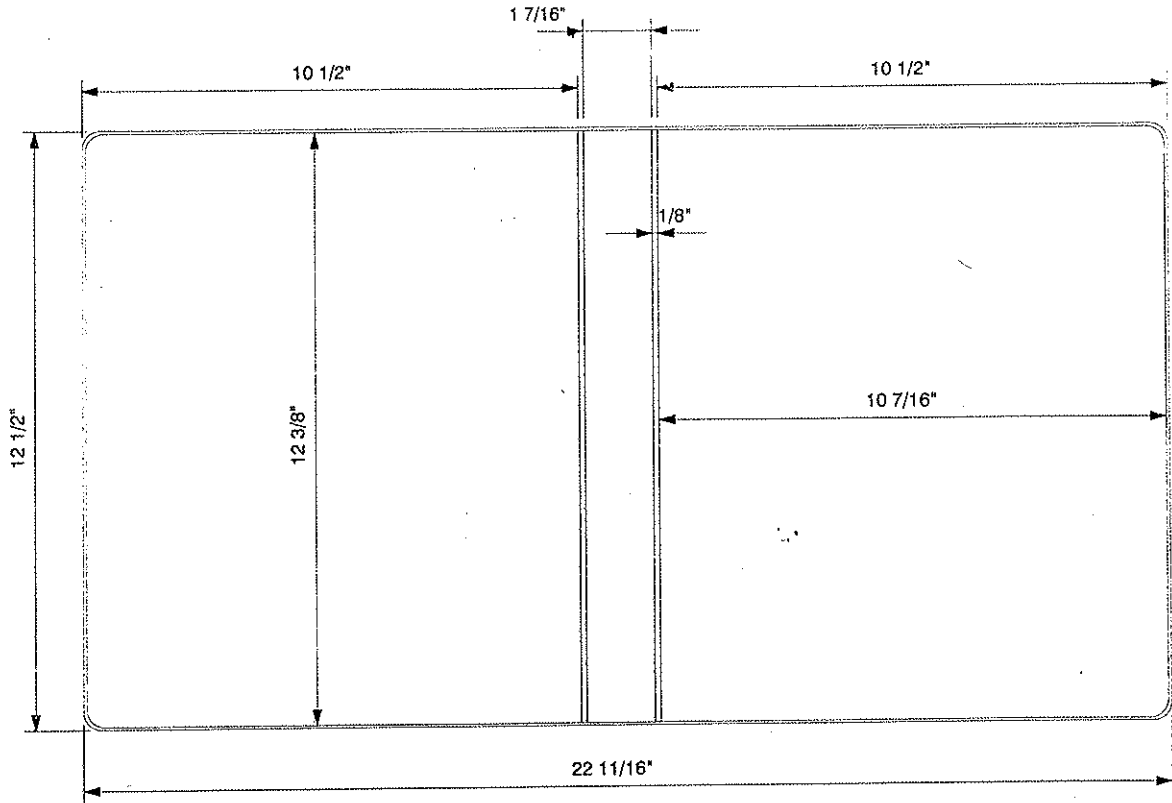

MATERIAL SPECS		GAUGE	PCS.	MATERIAL SPECS		GAUGE	PCS.				
COVER MAT.	13 1/4 X 23 1/2		1	LINING MAT.	13 1/4 X 23 1/2		1				
COVER MAT.	13 1/4 X 23 1/2		1	LINING MAT.							
DIE CUT				HORZ. PKT.							
COL				VERT. PKT.							
LABEL HOLDER				DIE CUT							
GUSSET				REINF.							
BOARD SPECS		5/16" R. CORNERS		GAUGE	PCS.	BOARD SPECS		5/16" R. CORNERS		GAUGE	PCS.
F.C. BOARD	12 9/32 X 10 11/32	120	1	F.C. BOARD							
B.B. BOARD	12 9/32 X 1 11/32	120	1	B.B. BOARD							
B.C. BOARD	13 9/32 X 10 11/32	120	1	B.C. BOARD							
FLAP BD.				DIE CUT							
BOARD				DIE CUT							

DIE #	6571	METAL	1" ANGLE D	RADIUS	3/8"
ORDER #	168807	CUSTOMER	ODEN & ASSOCIATES	TEAR SEAL	.014
SHEET SIZE	12 5/8 X 10 3/4	STYLE CASE	VINYL BINDER	BAR SEAL	253
CAP.	1.5	DUE DATE	10-9-98	COMPLETED	
LOCATION	B-18-8	QUANTITY	550	DATE	9-29-98

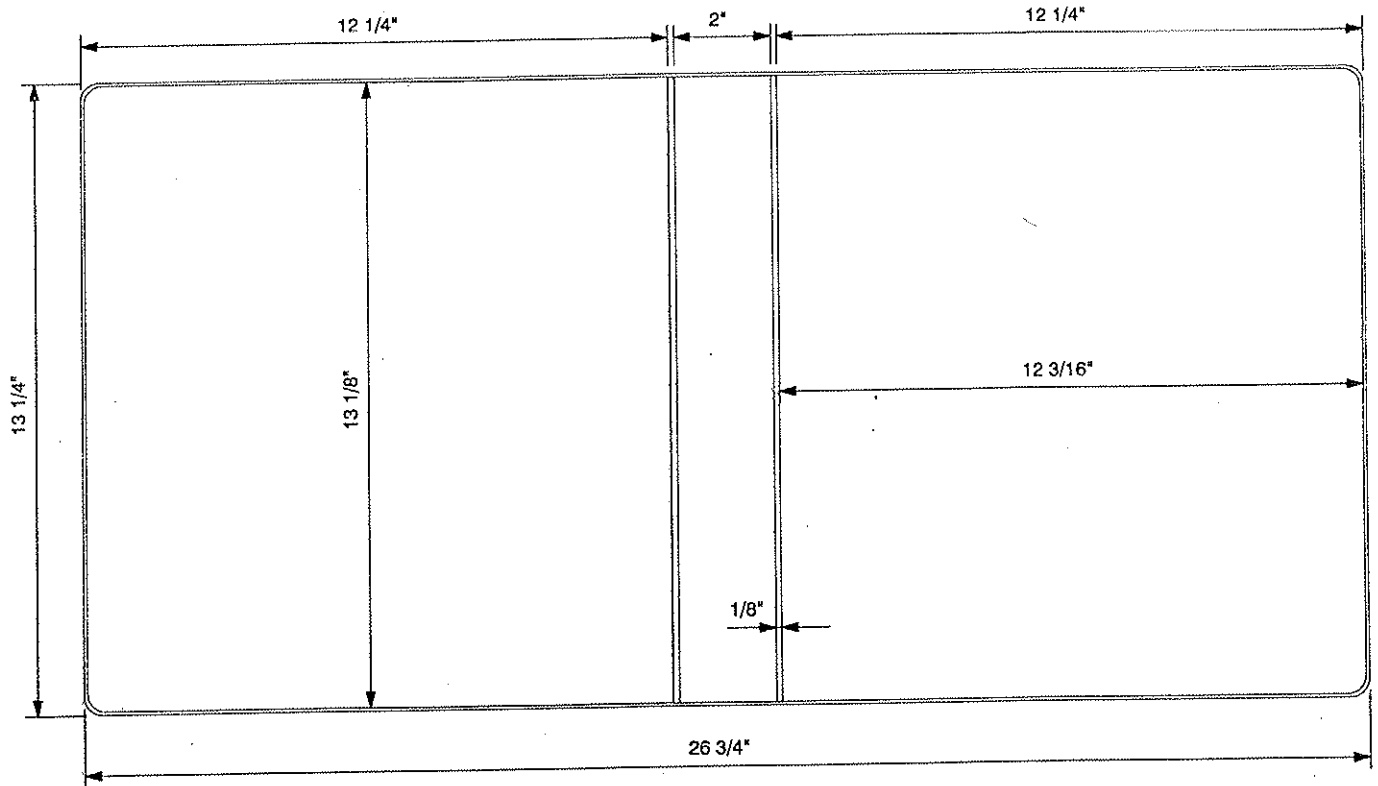

MATERIAL SPECS		GAUGE		PCS.		MATERIAL SPECS		GAUGE		PCS.					
COVER MAT.	14 X 27 1/2			1		LINING MAT.	14 X 27 1/2								
COVER MAT.						LINING MAT.									
DIE CUT						HORZ. PKT.									
COL	13 7/16 X 14 7/8			1		VERT. PKT.									
LABEL HOLDER						DIE CUT									
GUSSET						REINF.									
BOARD SPECS		5/16" R. CORNERS		GAUGE		PCS.		BOARD SPECS		5/16" R. CORNERS		GAUGE		PCS.	
F.C. BOARD	13 1/16 X 12 1/8			100		1		F.C. BOARD							
B.B. BOARD	13 1/16 X 1 29/32			100		1		B.B. BOARD							
B.C. BOARD	13 1/16 X 12 1/8			100		1		B.C. BOARD							
FLAP BD.								DIE CUT							
BOARD								DIE CUT							

DIE #	6753-A	METAL	STR D	RADIUS	3/8"
ORDER #	266829	CUSTOMER	MORGAN STANLEY	TEAR SEAL	.014
SHEET SIZE	11.25 X 9.75	STYLE CASE	VINYL RING BINDER	BAR SEAL	48-3
CAP.	1 1/2"	DUE DATE	9-23-99	COMPLETED	
LOCATION	H-8-3	QUANTITY	25000	DATE	8-23-99

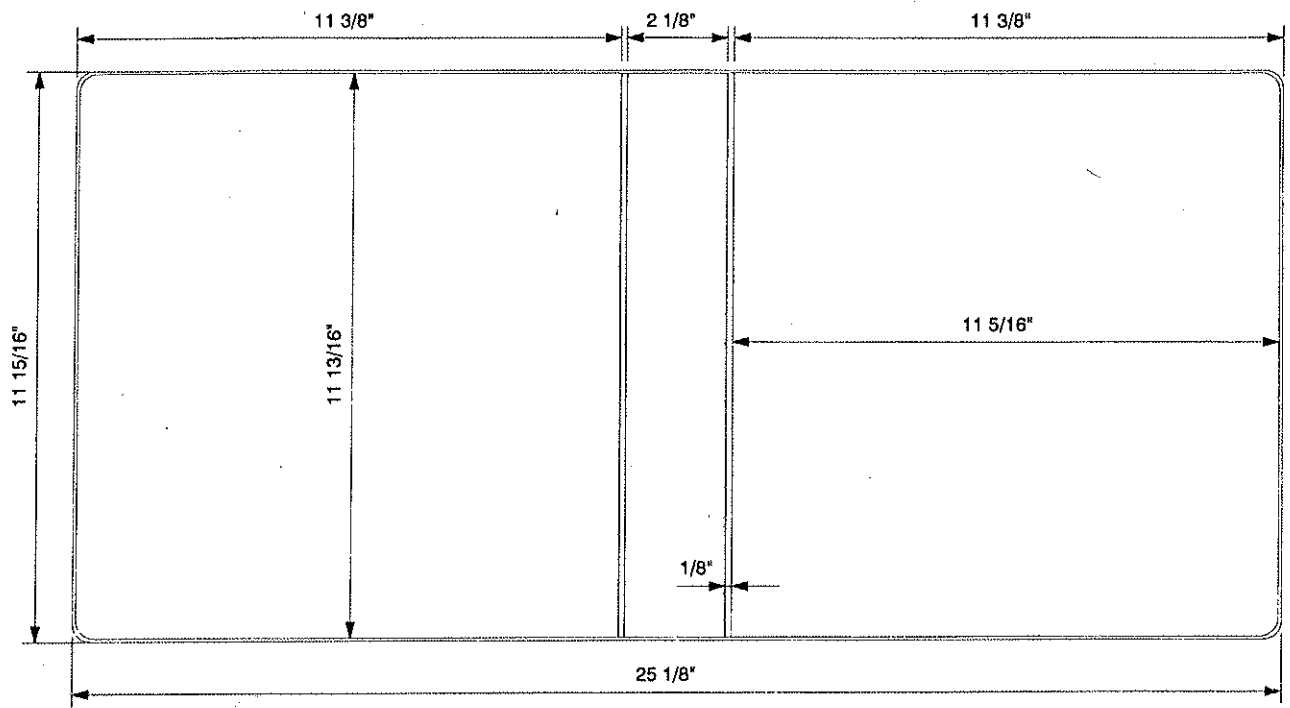

MATERIAL SPECS		GAUGE	PCS.	MATERIAL SPECS		GAUGE	PCS.
COVER MAT.	12 15/16 X 26 1/8		1	LINING MAT.	12 11/16 X 25 7/8		1
COVER MAT.				LINING MAT.			
DIE CUT				HORZ. PKT.			
COL				VERT. PKT.			
LABEL HOLDER				DIE CUT			
GUSSET				REINF.			
BOARD SPECS		GAUGE	PCS.	BOARD SPECS		GAUGE	PCS.
F.C. BOARD	11 23/32 X 11 7/32		1	F.C. BOARD			
B.B. BOARD	11 23/32 X 2 1/32		1	B.B. BOARD			
B.C. BOARD	11 23/32 X 11 7/32		1	B.C. BOARD			
FLAP BD.				DIE CUT			
BOARD				DIE CUT			

DIE #	6818	METAL	ANGLE D W/B	RADIUS	3/8"
ORDER #	290482	CUSTOMER	SAM STEWART FW	TEAR SEAL	.012
SHEET SIZE	11 X 13 1/4	STYLE CASE	VINYL RING BINDER	BAR SEAL	254
CAP.	2 1/2"	DUE DATE	12-22-99	COMPLETED	
LOCATION		QUANTITY	500	DATE	12-7-99

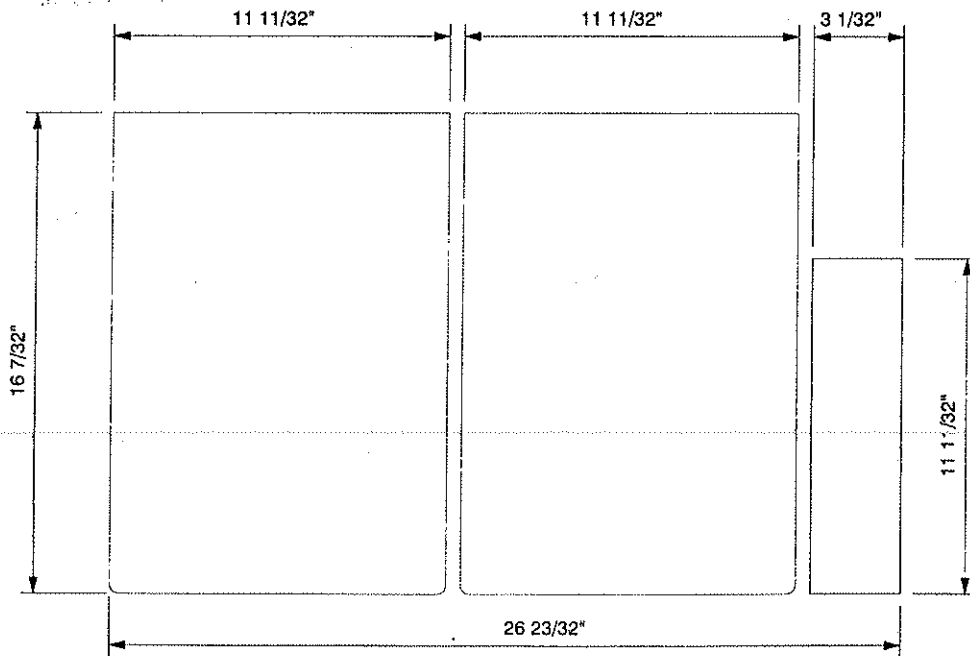
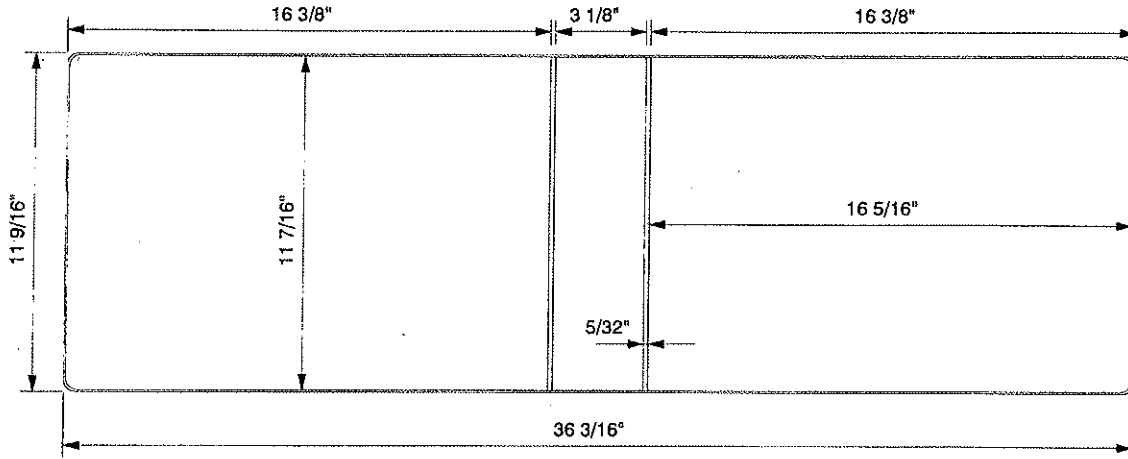

MATERIAL SPECS		GAUGE	PCS.	MATERIAL SPECS		GAUGE	PCS.
COVER MAT.	12 9/16 X 37 3/16		1	LINING MAT.	12 5/16 X 37		1
COVER MAT.				LINING MAT.			
DIE CUT				HORZ. PKT.			
BOARD SPECS		GAUGE	PCS.	BOARD SPECS		GAUGE	PCS.
BOARD	5/16" R. CORNERS 17 7/32 X 27 23/32		120	5/16" R. CORNERS DIE CUT			1