

Product Code

Style Case Ring Binder

Sheet Size 5 X 3

Cap. 1/2

Die No. 3774

Order No. 955019

Plate

Customer

Zone VI Studios, Inc.

Metal	
Total Vinyl	<u>.030</u>
Quantity	<u>1,000</u>
Date	<u>4-15-87</u>
Type Corners	<u>Rd</u>
Radius	<u>1/4</u>
Completed	

	Gauge	Thick
Tear Seal	<u>.016</u>	<u>3/32</u>
Bar Seal	<u>102</u>	<u>3/32</u>
Bar Seal		

	No. of Feet
Tear Seal	
Bar Seal	
Bar Seal	

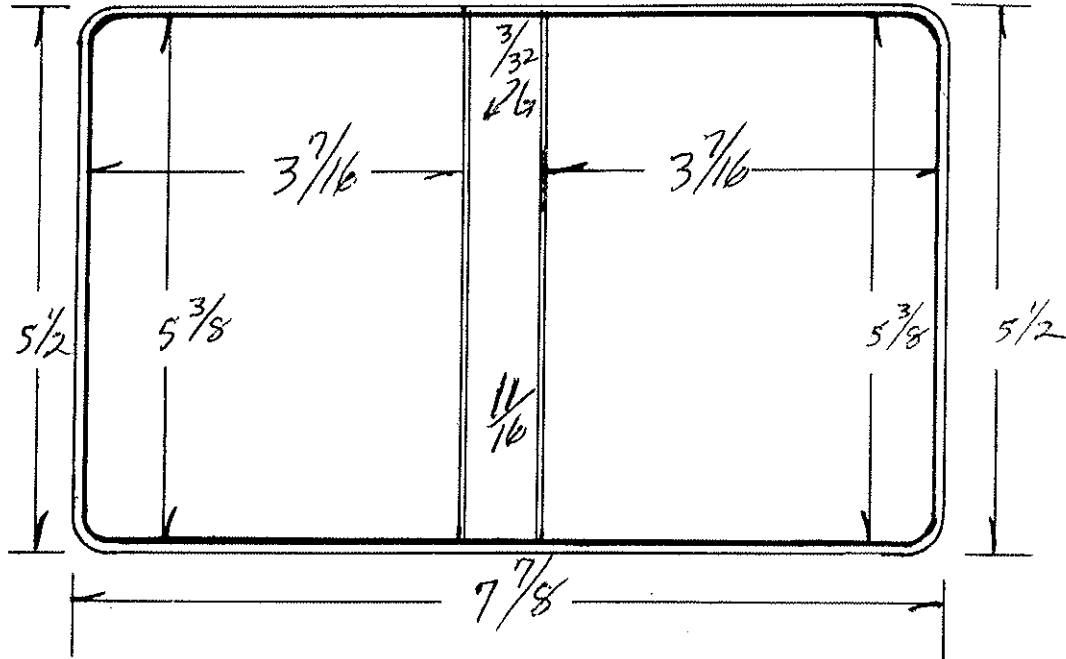

Code	Ga.	PCS	Cutting Specs		Code	Ga.	Pcs.	Cutting Specs	
			Size	Out				Size	Out
Cover Mat.			$6\frac{1}{8} \times 8\frac{1}{2}$	1	Lining Mat.			$6\frac{1}{8} \times 8\frac{1}{2}$	1
Cover Mat			X		Lining Mat.			X	
Vert. Pckt.			$6\frac{1}{8} \times 1\frac{3}{16}$	2	Horz. Pckt.			X	
Vert. Pckt.			X		Horz. Pckt.			X	
Pocket			X		Pocket			X	
Label Holder			X		Card Holder			X	
Material			X		Material			X	
Material			X		Material			X	
Material			X		Material			X	
F.C. Board			$5\frac{5}{16} \times 3\frac{3}{8}$	1	B.C. Board			$5\frac{5}{16} \times 3\frac{3}{8}$	1
B.C. Board			X		B.B. Board			$5\frac{5}{16} \times 5\frac{5}{8}$	1
Center Board			X		Board			X	
Board			X		Strip			X	
Cover Pad			X		Strip			X	
					B.B. Pad			X	

K.P.D.

Product Code

Style Case *V R B*

Sheet Size *4 1/4 X 10 1/4*

Cap. *1 1/2* Die No. *3955*

Order No. *1000134*

1000134

Plate

Customer *Westview Instruments*

Metal
Total Vinyl
Quantity <i>1</i>
Date
Type Corners <i>Rd</i>
Radius <i>3/32</i>
Completed

	Gauge	Thick
Tear Seal	<i>16</i>	<i>3/32</i>
Bar Seal	<i>Everlast</i>	<i>light</i>
Bar Seal		

	No. of Feet
Tear Seal	
Bar Seal	
Bar Seal	

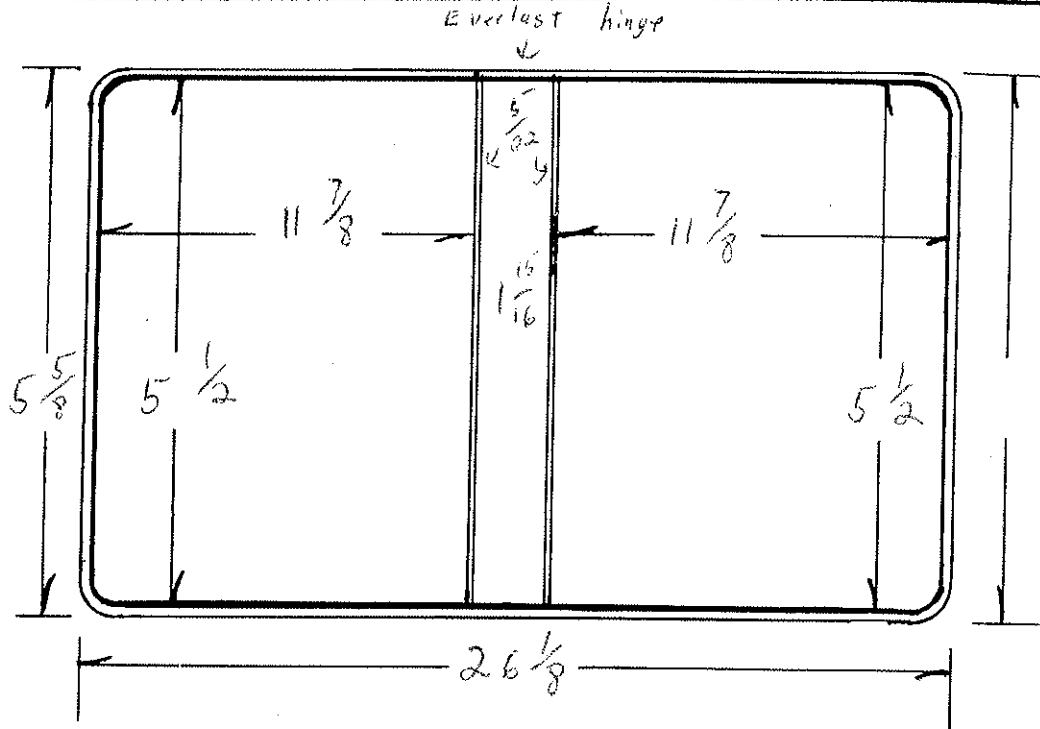

Code	Ga.	#	Cutting Specs		Code	Ga.	#	Cutting Specs	
			Size	Out				Size	Out
Cover Mat.			<i>6 3/8 X 26 3/4</i>	<i>1</i>	Lining Mat.			<i>6 3/8 X 26 3/4</i>	<i>1</i>
Cover Mat.			X		Lining Mat.			X	
Vert. Pckt.			X		Horz. Pckt.			X	
Vert. Pckt.			X		Horz. Pckt.			X	
Pocket			X		Pocket			X	
Label Holder			X		Card Holder			X	
Material			X		Material			X	
Material			X		Material			X	
Material			X		Material			X	
F.C. Board			<i>5 12/32 X 11 25/32</i>	<i>1</i>	B.C. Board			<i>5 12/32 X 11 25/32</i>	<i>1</i>
B.C. Board			X		B.B. Board			<i>5 12/32 X 1 27/32</i>	<i>1</i>
Center Board			X		Board			X	
Board			X		Strip			X	
Cover Pad			X		Strip			X	
					B.B. Pad			X	

Product Code

Style Case **VRB**

Sheet Size $3\frac{3}{4}$ X $7\frac{1}{4}$ Cap. $\frac{1}{2}$

Die No. **4114**

Order No. **961330.1**

Plate

Customer **Spiegel Bros.**

Metal
Total Vinyl
Quantity
Date
Type Corners RND
Radius $\frac{3}{8}$
Completed

	Gauge	Thick
Tear Seal	.016	$\frac{1}{16}$
Bar Seal	#253	$\frac{1}{8}$
Bar Seal		

	No. of Feet
Tear Seal	
Bar Seal	
Bar Seal	

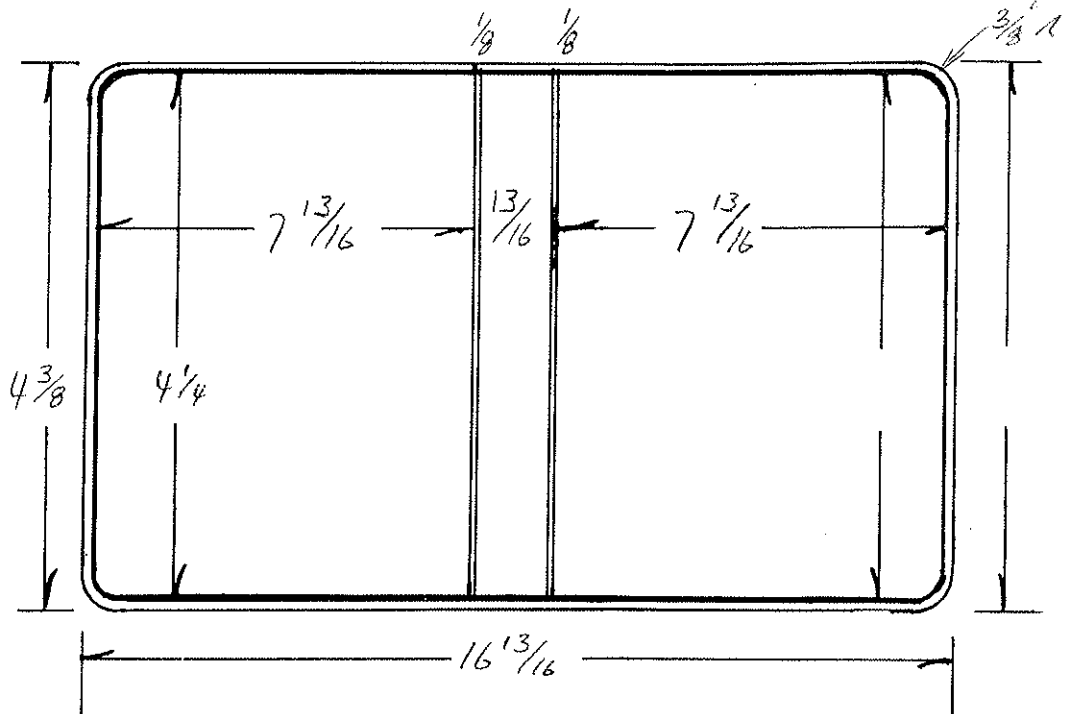

Code	Ga.	#	Cutting Specs		Code	Ga.	#	Cutting Specs	
			Size	Out				Size	Out
Cover Mat.			$5\frac{1}{4}$	$17\frac{5}{8}$	Lining Mat.			$5\frac{1}{4}$	$17\frac{5}{8}$
Cover Mat.					Lining Mat.				
Vert. Pckt.					Horz. Pckt.				
Vert. Rckt.					Horz. Pckt.				
Pocket					Pocket				
Label Holder					Card Holder				
Material					Material				
Material					Material				
Material					Material				
F.C. Board			$7\frac{23}{32}$	$4\frac{5}{32}$	B.C. Board				
B.C. Board			$7\frac{23}{32}$	$4\frac{5}{32}$	B.B. Board			$4\frac{5}{32}$	$23\frac{3}{32}$
Center Board					Board				
Board					Strip				
Cover Pad					Strip				
					B.B. Pad				

Product Code

Style Case *VRB 5-3-1/2"*

Sheet Size *5 X 4* Cap. *1/2*

Die No. *4814*

Order No. *969139*

Plate *C-17-4*

Customer

AGRI-CAO

7-11

Metal
Total Vinyl
Quantity <i>200</i>
Date <i>2-9-1</i>
Type Corners
Radius <i>3/8"</i>
Completed

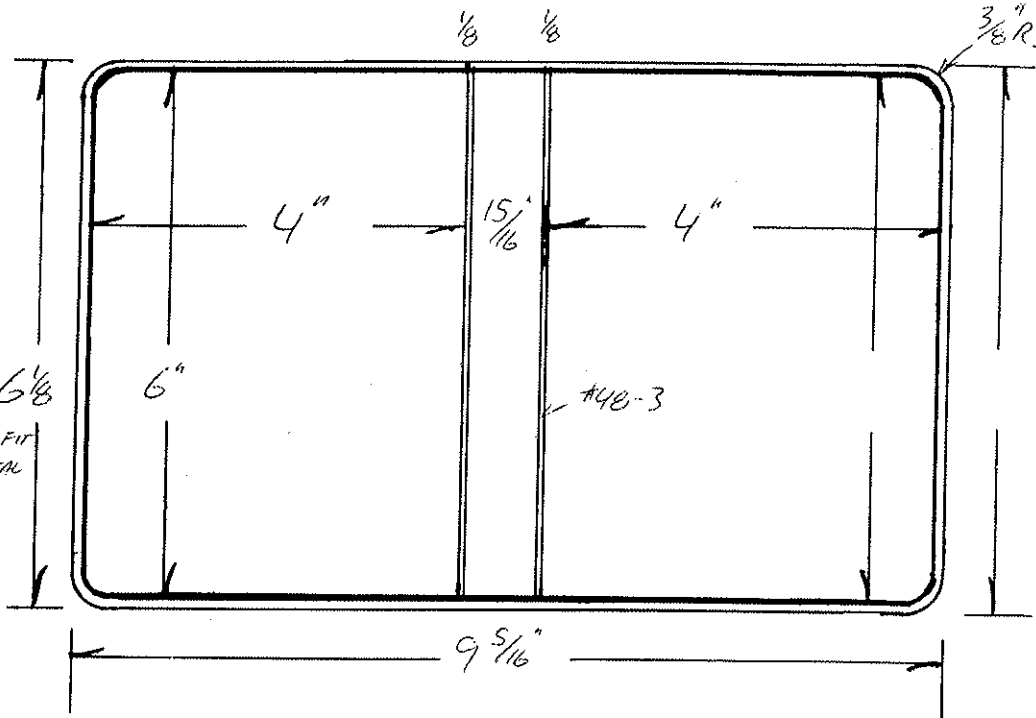

	Gauge	Thick
Tear Seal	<i>.014</i>	<i>1/16</i>
Bar Seal	<i>#48-3</i>	<i>1/8</i>
Bar Seal		

	No. of Feet
Tear Seal	
Bar Seal	
Bar Seal	

TO FIT METAL

OWG - B.P.
CHLH. KPV

Code	Ga.	Pcs	Cutting Specs		Code	Ga.	Pcs	Cutting Specs	
			Size	Out				Size	Out
Cover Mat.			<i>6 7/8</i>	<i>X 10 1/8</i>				<i>6 7/8</i>	<i>X 10 1/8</i>
Cover Mat.				X	Lining Mat.			X	
Vert. Pckt.				X	Horz. Pckt.			X	
Vert. Pckt.				X	Horz. Pckt.			X	
Pocket				X	Pocket			X	
Label Holder				X	Card Holder			X	
Material				X	Material			X	
Material				X	Material			X	
Material				X	Material			X	
F.C. Board			<i>5 29/32</i>	<i>X 3 29/32</i>	B.C. Board			X	
B.C. Board			<i>5 29/32</i>	<i>X 3 29/32</i>	B.B. Board			<i>5 29/32</i>	<i>X 27/32</i>
Center Board				X	Board			X	
Board				X	Strip			X	
Cover Pad				X	Strip			X	
					B.B. Pad			X	

Product Code

010 # 1880

Style Case

MEMO URB

Sheet Size $5\frac{3}{4} \times 4$

Cap. $\frac{1}{2}$

Die No. 4483

Order No. 966096

Plate

Customer

SERVICE GULLO

Metal
Total Vinyl
Quantity 100
Date 7-26-90
Type Corners
Radius $\frac{3}{8}$
Completed

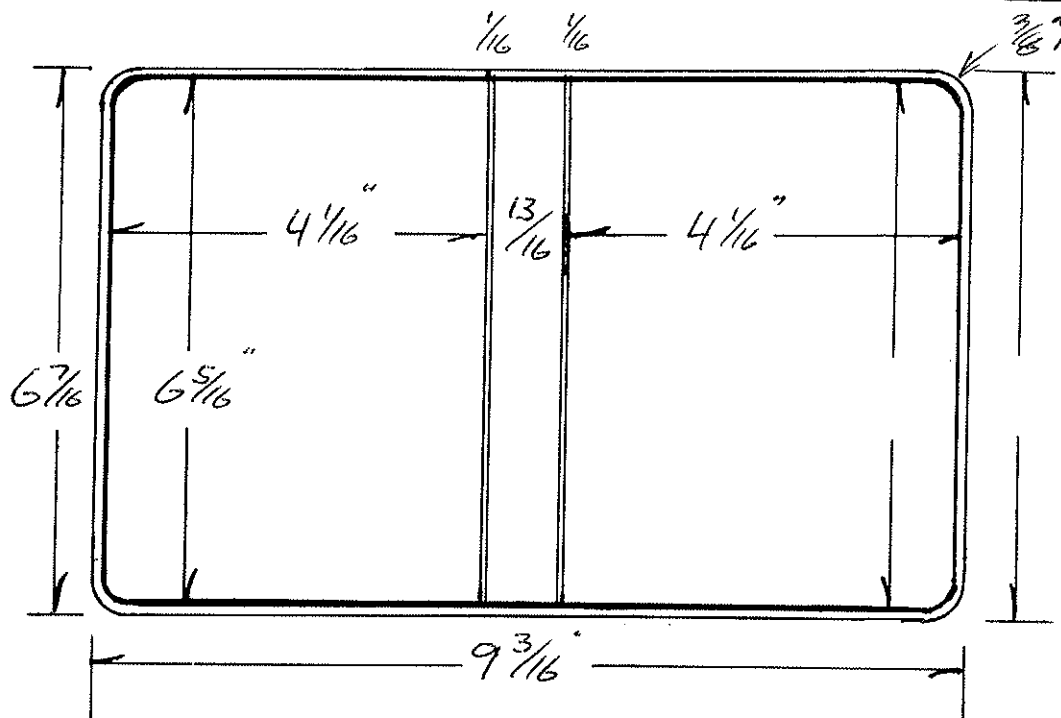

	Gauge	Thick
Tear Seal	#014	$\frac{1}{16}$
Bar Seal	#102	$\frac{1}{16}$
Bar Seal		

	No. of Feet
Tear Seal	
Bar Seal	
Bar Seal	

SIZE - B. Proc

Calculation only

Code	Ga.	# PCS	Cutting Specs		Code	Ga.	# Pcs.	Cutting Specs	
			Size	Out				Size	Out
Cover Mat.			$7\frac{1}{4} \times 10$	15 1	Lining Mat.			$7\frac{1}{4} \times 10$	15 1
Cover Mat.			X		Lining Mat.			X	
Vert. Pckt.			X		Horz. Pckt.			X	
Vert. Pckt.			X		Horz. Pckt.			X	
Pocket			X		Pocket			X	
Label Holder			X		Card Holder			X	
Material			X		Material			X	
Material			X		Material			X	
Material			X		Material			X	
F.C. Board			$6\frac{7}{32} \times 3\frac{31}{32}$	18 1	B.C. Board			X	
B.C. Board			$6\frac{7}{32} \times 3\frac{31}{32}$		B.B. Board			$6\frac{7}{32} \times 2\frac{23}{32}$	
Center Board			X		Board			X	
Board			X		Strip			X	
Cover Pad			X		Strip			X	
					B.B. Pad			X	

Product Code

Style Case VRB

Sheet Size 5 1/4 X 7 3/4 Cap. 3/4

Die No. 5773

Order No. 973512.1

Plate D12-2

Customer

Millipore Systems Division

10-16

Metal
Total Vinyl
Quantity <u>50</u>
Date <u>9-29</u>
Type Corners <u>Rnd</u>
Radius <u>3/8</u>
Completed

	Gauge	Thick
Tear Seal	<u>.014</u>	<u>1/16</u>
Bar Seal	<u>48.4</u>	<u>5/32</u>
Bar Seal		

	No. of Feet
Tear Seal	
Bar Seal	
Bar Seal	

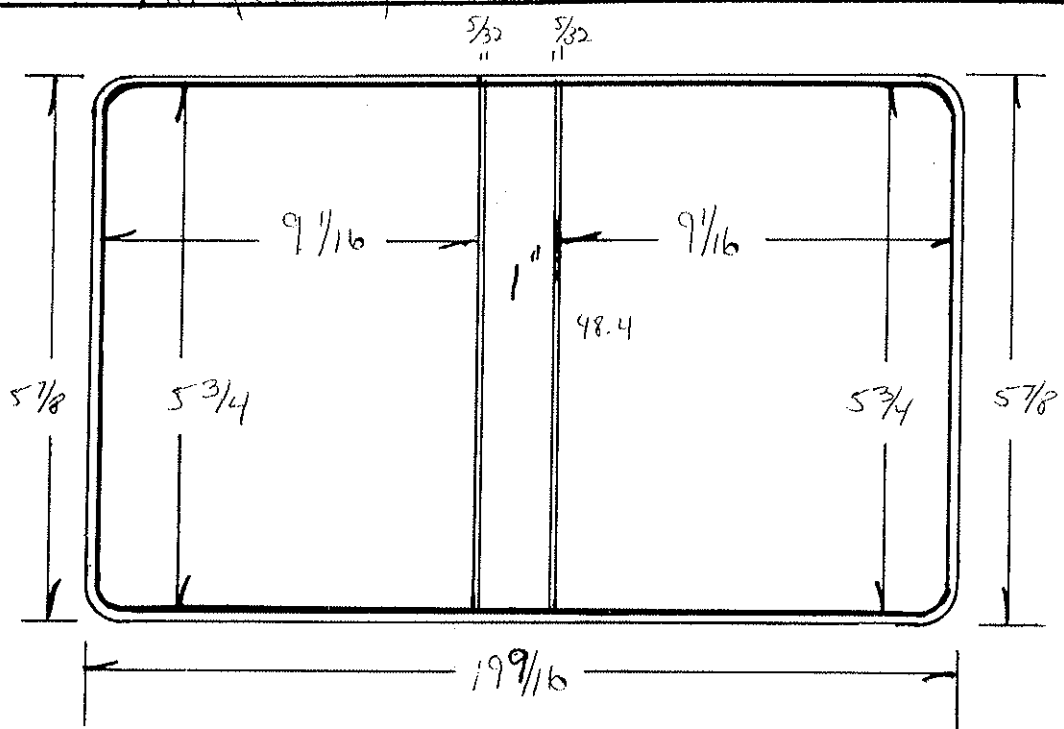

Tim

Code	Ga.	Pcs	Cutting Specs		Code	Ga.	Pcs	Cutting Specs			
			Size	Out				Size	Out		
Cover Mat.			<u>6 5/8 X 20 1/4</u>		Lining Mat.			<u>6 5/8 X 20 1/4</u>			
Cover Mat.			X		Lining Mat.			X			
Vert. Pckt.			X		Horz. Pckt.			X			
Vert. Pckt.			X		Horz. Pckt.			X			
Pocket			X		Pocket			X			
Label Holder			X		Card Holder			X			
Material			X		Material			X			
Material			X		Material			X			
Material			X		Material			X			
F.C. Board			<u>5 1/16 X 9</u>	<u>100</u>	1	B.C. Board			<u>5 21/32 X 8 3/32</u>	<u>100</u>	1
B.G. Board			<u>5 1/16 X 9</u>	<u>100</u>	1	B.B. Board			<u>29/32 X 8 3/32</u>	<u>100</u>	1
Center Board			<u>5 1/16 X 29/32</u>	<u>100</u>	1	FC Board			<u>5 21/32 X 8 3/32</u>	<u>100</u>	1
Board			<u>5 5/8 X 25/32</u>	<u>35</u>	1	Strip			X		
Cover Pad			X		Strip			X			
					B.B. Pad			X			

DIE #	5941	METAL	KM500F	RADIUS	3/8
ORDER #	982855	CUSTOMER	CONTINENTAL AIRLINES	TEAR SEAL	.014
SHEET SIZE		STYLE CASE	VRB	BAR SEAL	102
CAP.	1/2	DUE DATE	11-3-95	COMPLETED	
LOCATION		QUANTITY	250	DATE	10-25-95

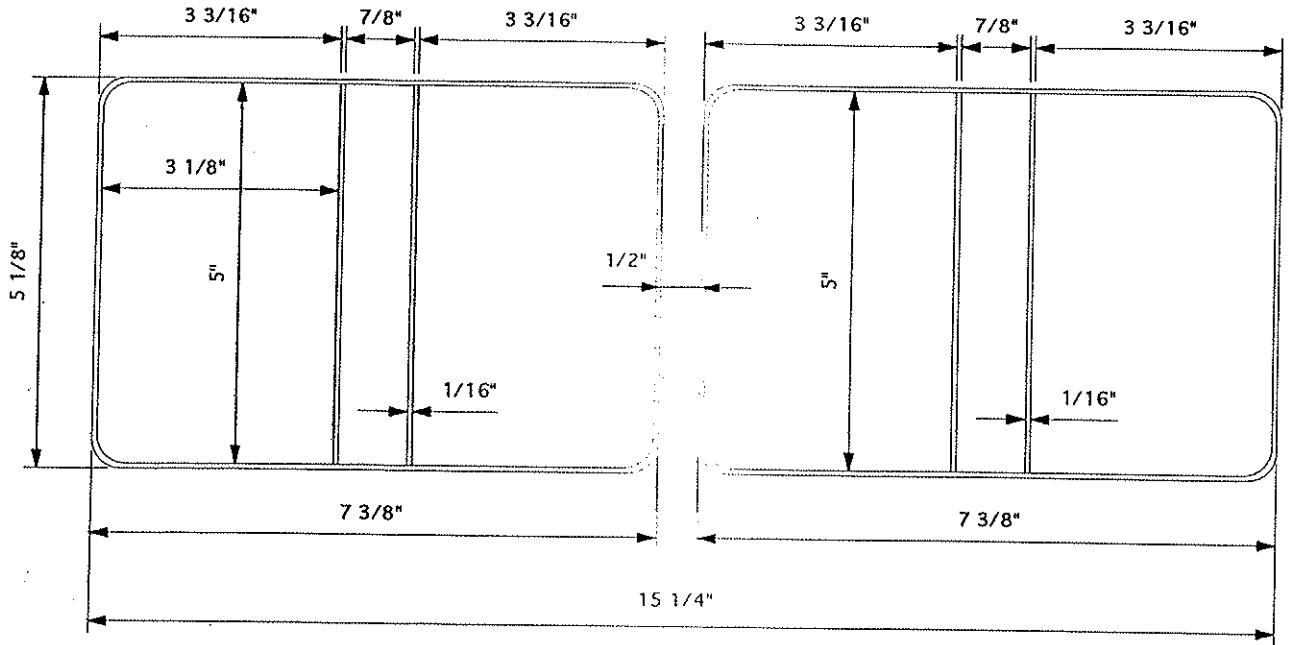

MATERIAL SPECS		GAUGE PCS.		MATERIAL SPECS		GAUGE PCS.	
COVER MAT.	5 7/8 x 16 (2 out)		1	LINING MAT.	5 7/8 x 16 (2 out)		1
COVER MAT.				LINING MAT.			
DIE CUT				HORZ. PKT.			
COL				VERT. PKT.			
LABEL HOLDER				DIE CUT			
GUSSET				REINF.			
BOARD SPECS		GAUGE PCS.		BOARD SPECS		GAUGE PCS.	
F.C. BOARD	4 15/16 x 3 1/16	48	1	F.C. BOARD			
B.B. BOARD	4 15/16 x 25/32	48	1	B.B. BOARD			
B.C. BOARD	4 15/16 x 3 1/16	48	1	B.C. BOARD			
B.U. STRIP				DIE CUT			
DIE CUT				DIE CUT			

DIE #	6342	METAL		RADIUS	1/4"
ORDER #	988289	CUSTOMER	KIKI A.	TEAR SEAL	.012
SHEET SIZE	5 X 5 1/4	STYLE CASE	VRB	BAR SEAL	102
CAP.	1/2"	DUE DATE	10-15-97	COMPLETED	
LOCATION	I-3-5	QUANTITY	3	DATE	9-30-97

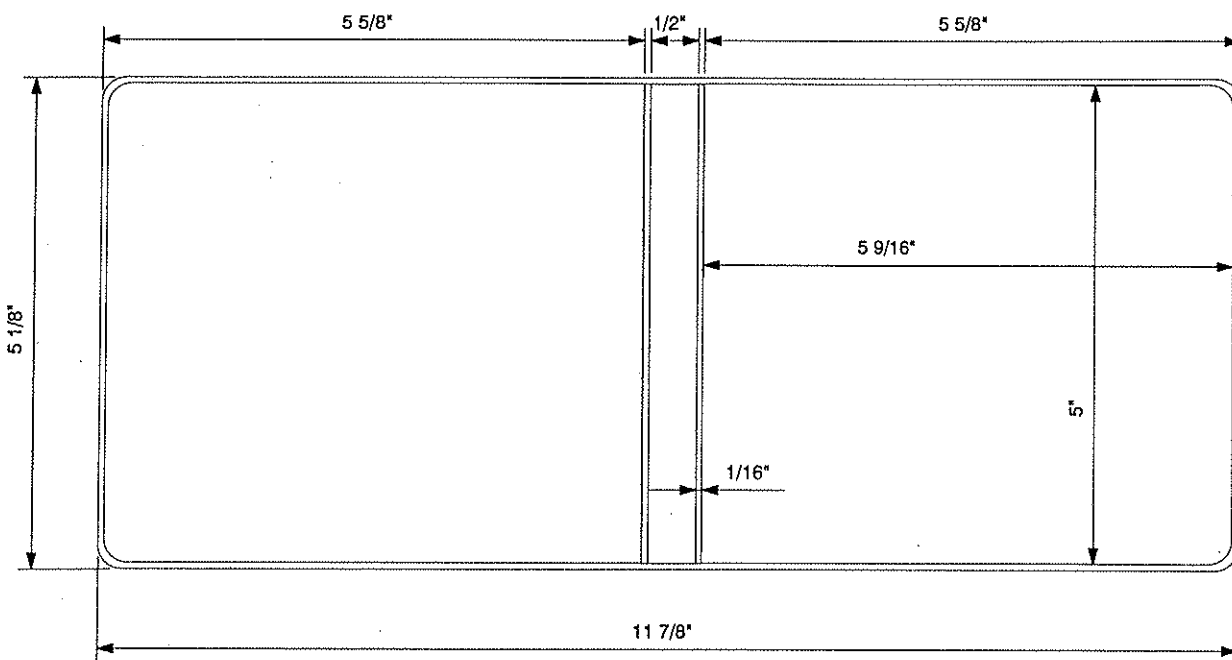

MATERIAL SPECS		GAUGE		MATERIAL SPECS		GAUGE	
COVER MAT.	5 7/8 X 12 5/8		1	LINING MAT.	5 7/8 X 12 5/8		1
COVER MAT.				LINING MAT.			
DIE CUT				HORZ. PKT.			
COL				VERT. PKT.			
LABEL HOLDER				DIE CUT			
GUSSET				REINF.			

BOARD SPECS		GAUGE		BOARD SPECS		GAUGE	
F.C. BOARD	4 15/16 X 5 1/2	100	1	F.C. BOARD			
B.B. BOARD	4 15/16 X 13/32	100	1	B.B. BOARD			
B.C. BOARD	4 15/16 X 5 1/2	100	1	B.C. BOARD			
FLAP BD.				DIE CUT			
BOARD				DIE CUT			

DIE #	6351	METAL	MEMO	RADIUS	3/8"
ORDER #	988407	CUSTOMER	DIESEL POWER	TEAR SEAL	.010
SHEET SIZE	5 1/2 X 4 1/4	STYLE CASE	VINYL RING BINDER	BAR SEAL	253
CAP.	3/4"	DUE DATE	11-5-97	COMPLETED	
LOCATION	1-2-9	QUANTITY	260	DATE	10-20-97

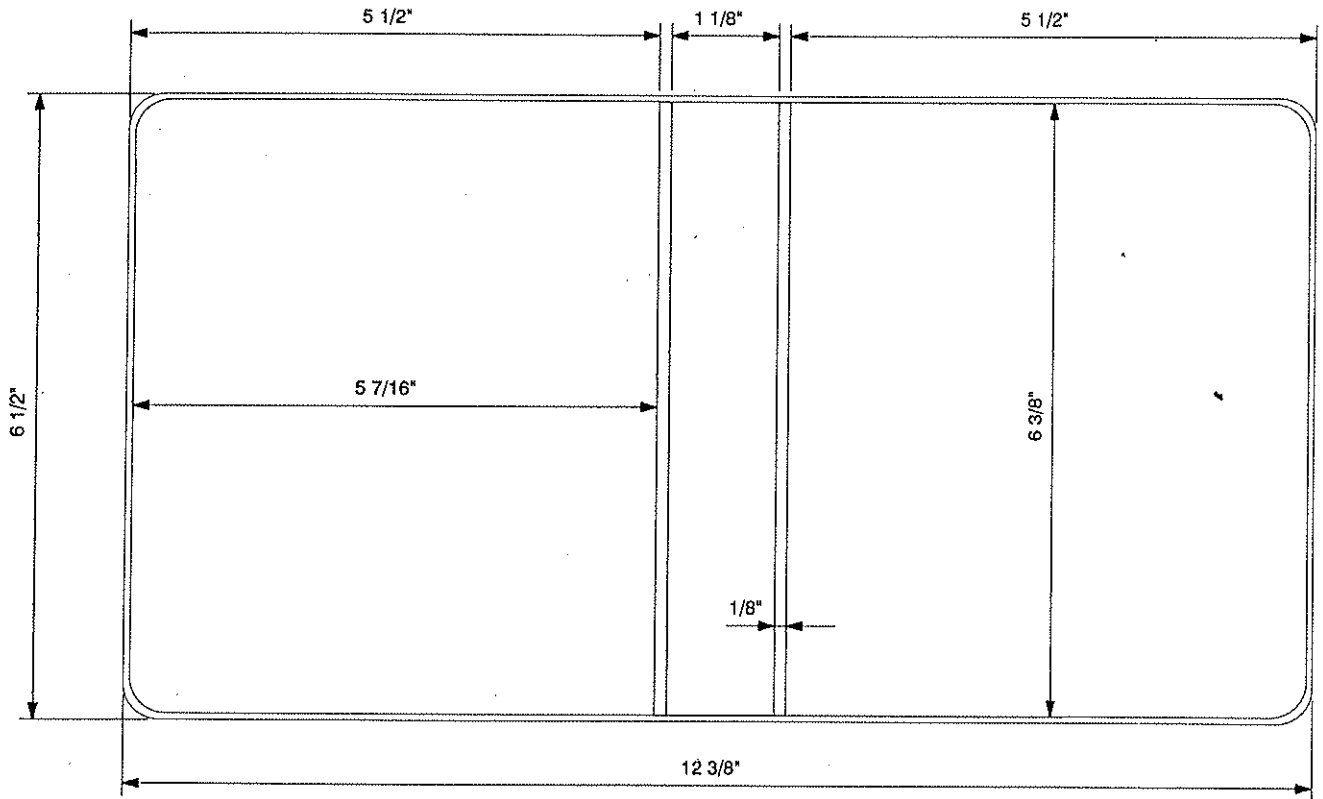

MATERIAL SPECS		GAUGE		MATERIAL SPECS		GAUGE	
COVER MAT.	7 1/4 X 13 1/8		1	LINING MAT.	7 1/4 X 13 1/8		1
COVER MAT.				LINING MAT.			
DIE CUT				HORZ. PKT.			
COL				VERT. PKT.			
LABEL HOLDER				DIE CUT			
GUSSET				REINF.			

BOARD SPECS		GAUGE		BOARD SPECS		GAUGE	
F.C. BOARD	6 5/16 X 5 3/8	100	1	F.C. BOARD			
B.B. BOARD	6 5/16 X 1 1/32	100	1	B.B. BOARD			
B.C. BOARD	6 5/16 X 5 3/8	100	1	B.C. BOARD			
FLAP BD.				DIE CUT			
BOARD				DIE CUT			

DIE #	6457-R	METAL	1/2" MEMO 1 BOOSTER	RADIUS	3/8"
ORDER #	989509	CUSTOMER	NYPRO CORPORATE	TEAR SEAL	.012
SHEET SIZE	5 X 3 1/8	STYLE CASE	VINYL BINDER	BAR SEAL	253
CAP.	1/2"	DUE DATE	3-30-98	COMPLETED	
LOCATION		QUANTITY	800	DATE	4-7-98

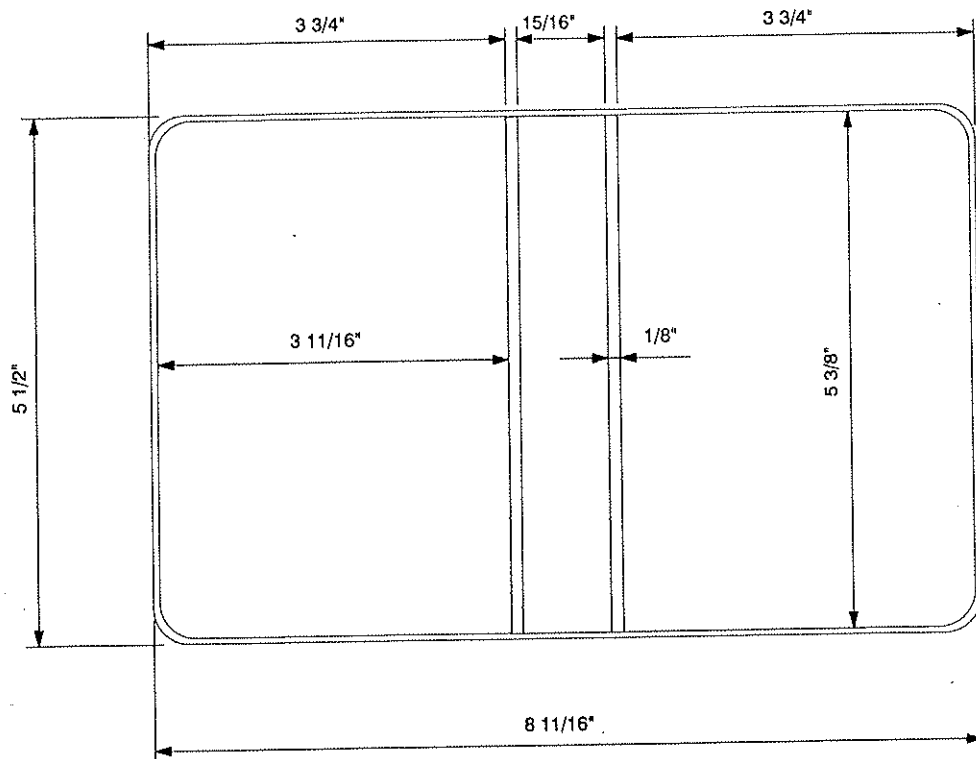

MATERIAL SPECS		GAUGE PCS.		MATERIAL SPECS		GAUGE PCS.	
COVER MAT.	6 1/4 X 9 1/2		1	LINING MAT.	6 1/4 X 9 1/2		
COVER MAT.				LINING MAT.			
DIE CUT				HORZ. PKT.			
COL				VERT. PKT.			
LABEL HOLDER				DIE CUT			
GUSSET				REINF.			

BOARD SPECS		GAUGE PCS.		BOARD SPECS		GAUGE PCS.	
F.C. BOARD	5 5/16 X 3 5/8	80	1	F.C. BOARD			
B.B. BOARD	5 5/16 X 27/32	80	1	B.B. BOARD			
B.C. BOARD	5 5/16 X 3 5/8	80	1	B.C. BOARD			
FLAP BD.				DIE CUT			
BOARD				DIE CUT			

DIE #	6358	METAL	2 RING ROUND NB	RADIUS	3/8"
ORDER #	988194	CUSTOMER	LEARN PUBLICATIONS	TEAR SEAL	.012
SHEET SIZE	5 1/2 X 3 1/2	STYLE CASE	VINYL RING BINDER	BAR SEAL	253
CAP.	1 1/2"	DUE DATE	11-7-97	COMPLETED	
LOCATION	1-2-7	QUANTITY	100	DATE	10-22-97

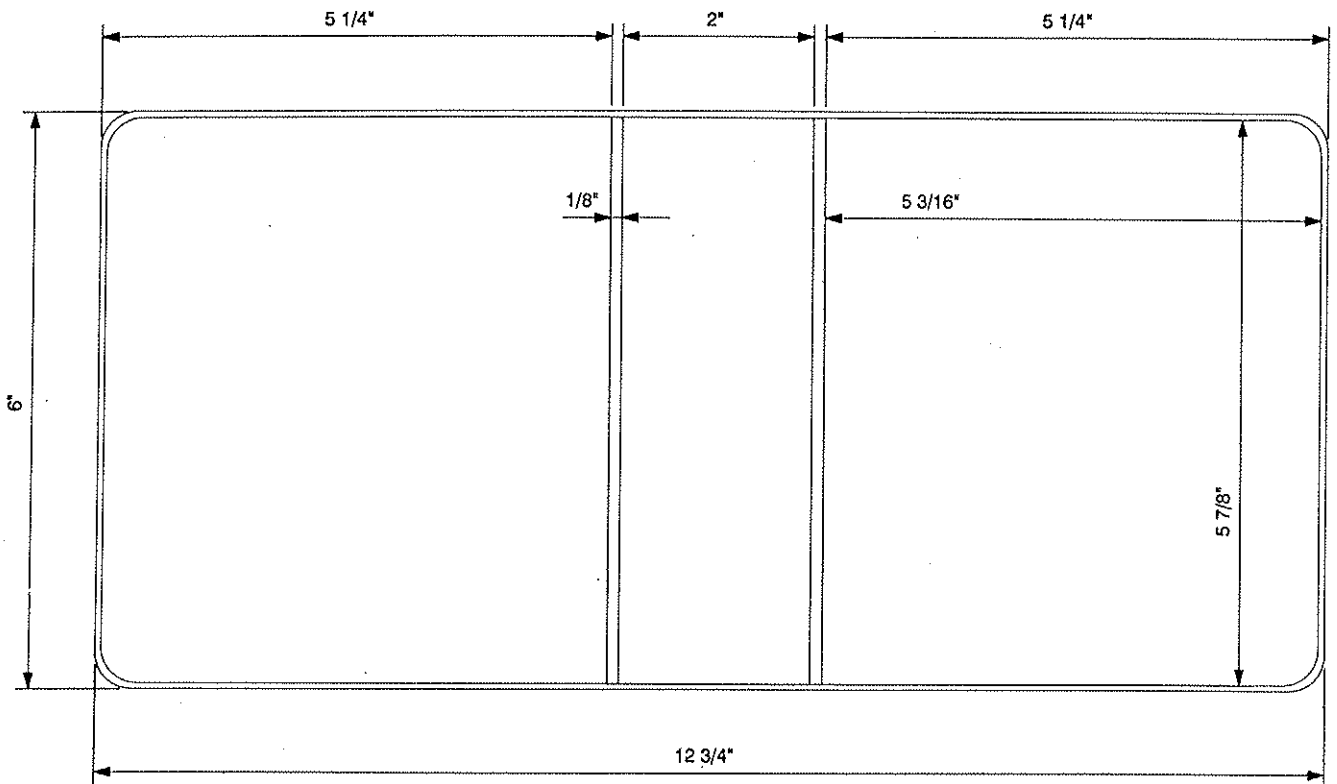

MATERIAL SPECS		GAUGE		PCS.		MATERIAL SPECS		GAUGE		PCS.	
COVER MAT.	6 3/4 X 13 1/2			1		LINING MAT.	6 3/4 X 13 1/2			1	
COVER MAT.						LINING MAT.					
DIE CUT						HORZ. PKT.					
COL						VERT. PKT.					
LABEL HOLDER						DIE CUT					
GUSSET						REINF.					
BOARD SPECS		GAUGE		PCS.		BOARD SPECS		GAUGE		PCS.	
F.C. BOARD	5 13/16 X 5 1/8	100	1			F.C. BOARD					
B.B. BOARD	5 13/16 X 1 29/32	100	1			B.B. BOARD					
B.C. BOARD	5 13/16 X 5 1/8	100	1			B.C. BOARD					
FLAP BD.						DIE CUT					
BOARD						DIE CUT					

DIE #	6660	METAL	1 3/4" SCREW POST	RADIUS
ORDER #	216135	CUSTOMER	MATSUMOTO	TEAR SEAL .008
SHEET SIZE	OA 5.125 X 9.8125	STYLE CASE	VINYL SCREWPOST BINDER	BAR SEAL 253
CAP.	1 3/4"	DUE DATE	3-11-99	COMPLETED
LOCATION	I-10-5	QUANTITY	1	DATE 3-4-99

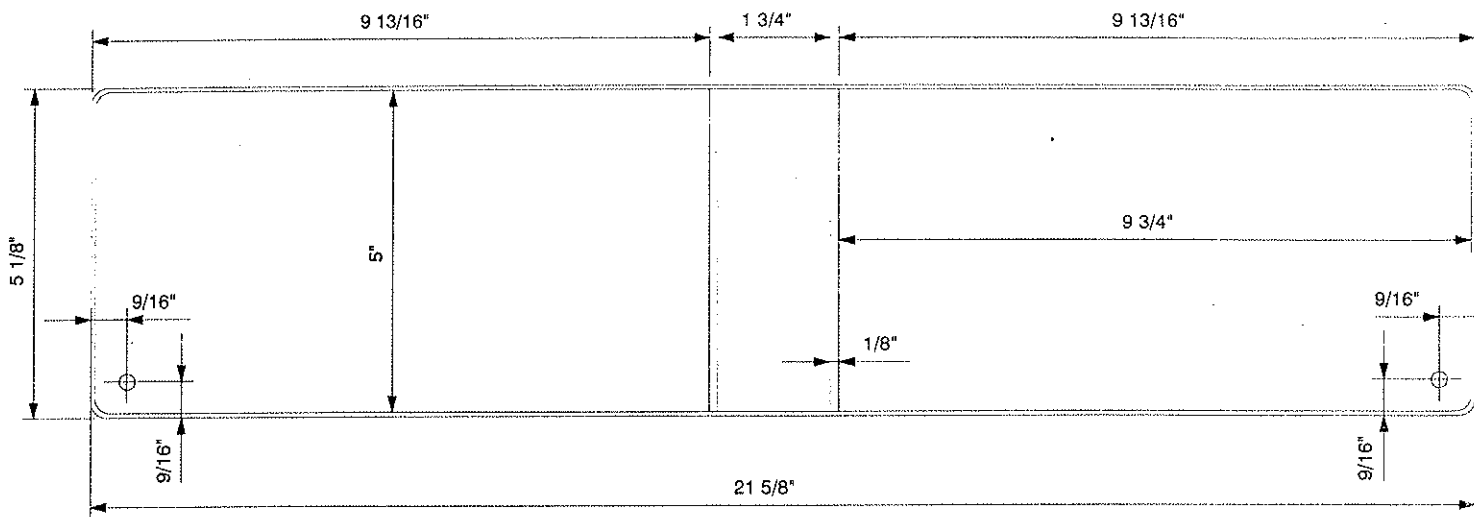

MATERIAL SPECS		GAUGE		MATERIAL SPECS		GAUGE	
COVER MAT.	5 7/8 X 22 3/8		1	LINING MAT.	5 7/8 X 22 3/8		1
COVER MAT.				LINING MAT.			
DIE CUT				HORIZ. PKT.			
COL				VERT. PKT.			
LABEL HOLDER				DIE CUT			
GUSSET				REINF.			
BOARD SPECS		5/16" R. CORNERS		BOARD SPECS		5/16" R. CORNERS	
F.C. BOARD	4 15/16 X 9 11/16	POLY	100	1	F.C. BOARD		
B.B. BOARD	4 15/16 X 1 21/32	POLY	100	1	B.B. BOARD		
B.C. BOARD	4 15/16 X 9 11/16	POLY	100	1	B.C. BOARD		
FLAP BD.					DIE CUT		
BOARD					DIE CUT		

E #	6766	METAL	SCREW POST	RADIUS	
ORDER #		CUSTOMER	MAHARAM	TEAR SEAL	.010
SHEET SIZE	OA-5 X 9 3/4	STYLE CASE	VINYL SWATCH BOOK	BAR SEAL	253
AP.	7/8"	DUE DATE		COMPLETED	
LOCATION	H-9-4	QUANTITY	1	DATE	9-16-99

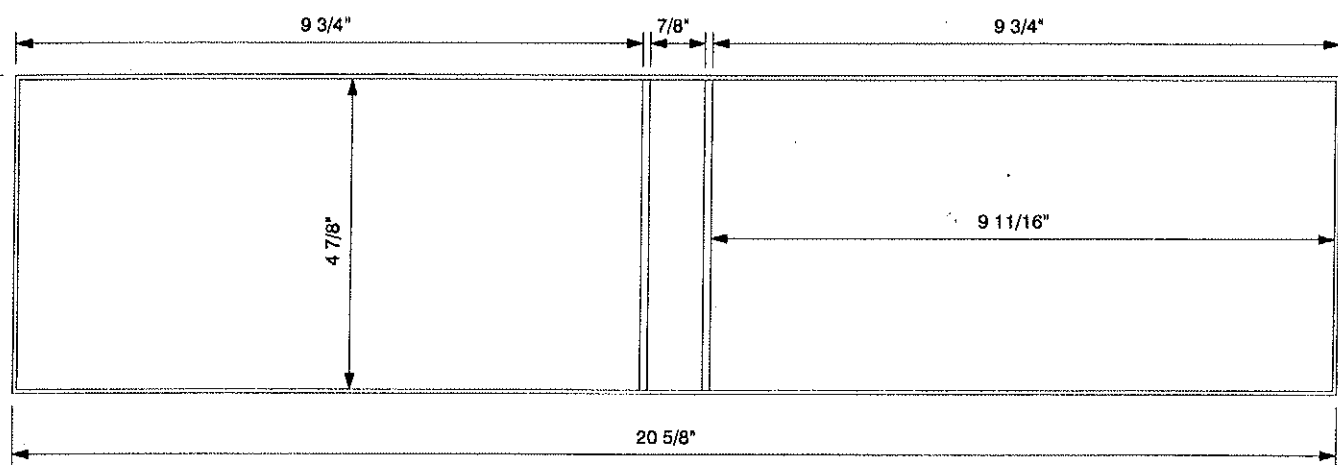

MATERIAL SPECS		GAUGE		PCS.		MATERIAL SPECS		GAUGE		PCS.			
COVER MAT.	5 3/4 X 21 3/8			1		LINING MAT.	5 3/4 X 21 3/8			1			
COVER MAT.						LINING MAT.							
DIE CUT						HORIZ. PKT.							
PL						VERT. PKT.							
BEL HOLDER	5 3/4 X 4 1/8			1		DIE CUT							
ASSET						REINF.							
BOARD SPECS		5/16" R. CORNERS		GAUGE		BOARD SPECS		5/16" R. CORNERS		GAUGE		PCS.	
C. BOARD	4 13/16 X 9 5/8	POLY	100	1		F.C. BOARD							
B. BOARD	4 13/16 X 25/32	POLY	100	1		B.B. BOARD							
C. BOARD	4 13/16 X 9 5/8	POLY	100	1		B.C. BOARD							
AP BD.						DIE CUT							
BOARD						DIE CUT							

DIE #	6790-R	METAL	SCREW POST	RADIUS	
ORDER #	285667	CUSTOMER	MAHARAM	TEAR SEAL	.010
SHEET SIZE	OA-5 X 9 3/4	STYLE CASE	VINYL SWATCH BOOK	BAR SEAL	253
CAP.	1"	DUE DATE	11-1-99	COMPLETED	
LOCATION		QUANTITY	4	DATE	11-1-99

REVISION - ADDED HOLE PUNCH

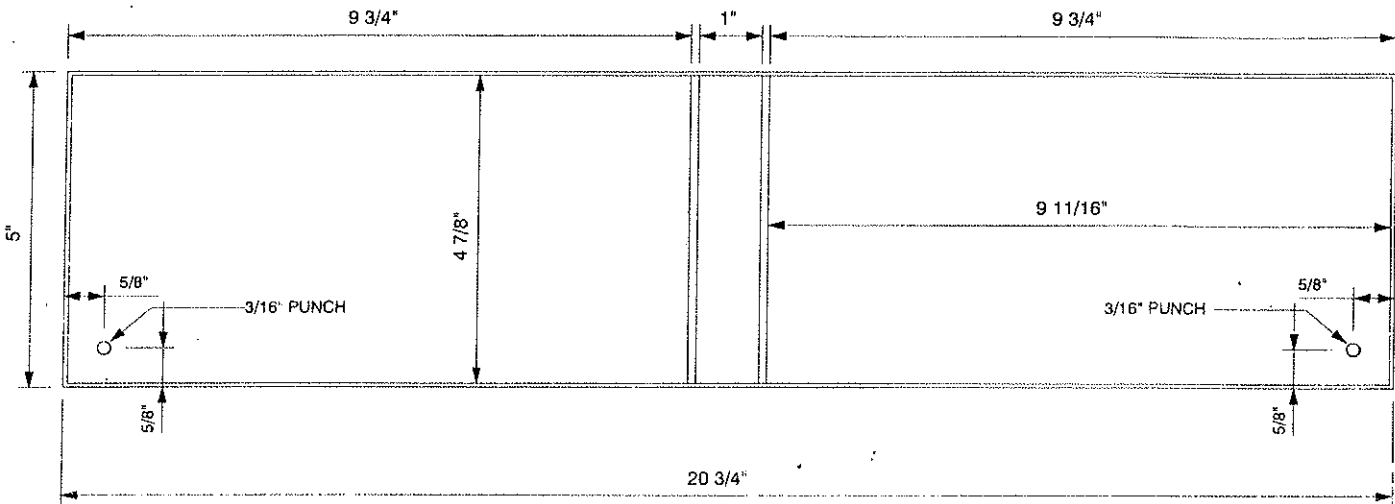

MATERIAL SPECS		GAUGE	PCS.	MATERIAL SPECS	GAUGE	PCS.
COVER MAT.	5 3/4 X 21 1/2		1	LINING MAT.	5 3/4 X 21 1/2	1
COVER MAT.				LINING MAT.		
DIE CUT				HORZ. PKT.		
COL				VERT. PKT.		
LABEL HOLDER	2 3/4 X 4 1/8		1	DIE CUT		
GUSSET				REINF.		

BOARD SPECS		GAUGE	PCS.	BOARD SPECS	GAUGE	PCS.
F.C. BOARD	4 13/16 X 9 5/8	POLY	100	F.C. BOARD		
B.B. BOARD	4 13/16 X 29/32	POLY	100	B.B. BOARD		
B.C. BOARD	4 13/16 X 9 5/8	POLY	100	B.C. BOARD		
FLAP BD.				DIE CUT		
BOARD				DIE CUT		

DIE #	6901	METAL	1 1/2" SCREW POST	RADIUS	
ORDER #	332646	CUSTOMER	MAHARAM	TEAR SEAL	.010
SHEET SIZE	OA-5 X 9 3/4	STYLE CASE	VINYL SWATCH BOOK	BAR SEAL	253
CAP.	1 5/16"	DUE DATE	4-25-00	COMPLETED	
LOCATION		QUANTITY	3	DATE	4-25-00

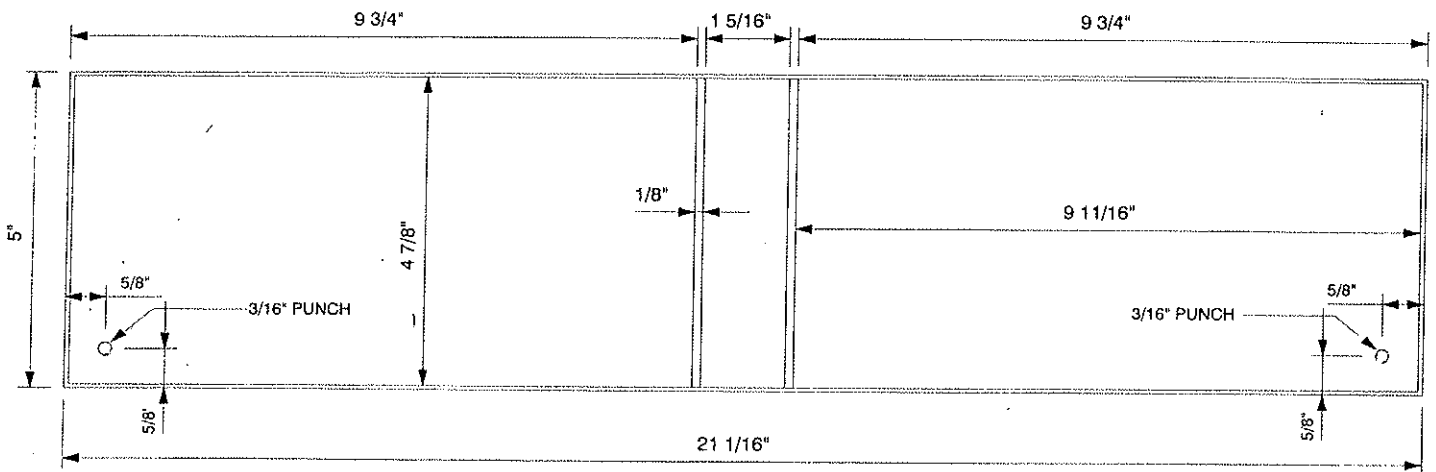

MATERIAL SPECS		GAUGE	PCS.	MATERIAL SPECS		GAUGE	PCS.
COVER MAT.	5 3/4 X 21 13/16		1	LINING MAT.	5 3/4 X 21 13/16		1
COVER MAT.				LINING MAT.			
DIE CUT				HORZ. PKT.			
COL				VERT. PKT.			
LABEL HOLDER	2 3/4 X 4 1/8		1	DIE CUT			
GUSSET				REINF.			
BOARD SPECS		5/16" R. CORNERS		BOARD SPECS		5/16" R. CORNERS	
F.C. BOARD	4 13/16 X 9 5/8	POLY	100	1	F.C. BOARD		
B.B. BOARD	4 13/16 X 1 7/32	POLY	100	1	B.B. BOARD		
B.C. BOARD	4 13/16 X 9 5/8	POLY	100	1	B.C. BOARD		
FLAP BD.					DIE CUT		
BOARD -					DIE CUT		

DIE #	6953	METAL	RR MEMO - 1 BOOSTER	RADIUS	3/8"
ORDER #	353068	CUSTOMER	21ST CENTURY PRESS	TEAR SEAL	.010
SHEET SIZE	5 x 3	STYLE CASE	VINYL BINDER	BAR SEAL	48-4
CAP.	1/2"	DUE DATE	8-7-00	COMPLETED	
LOCATION		QUANTITY	500	DATE	7-24-00

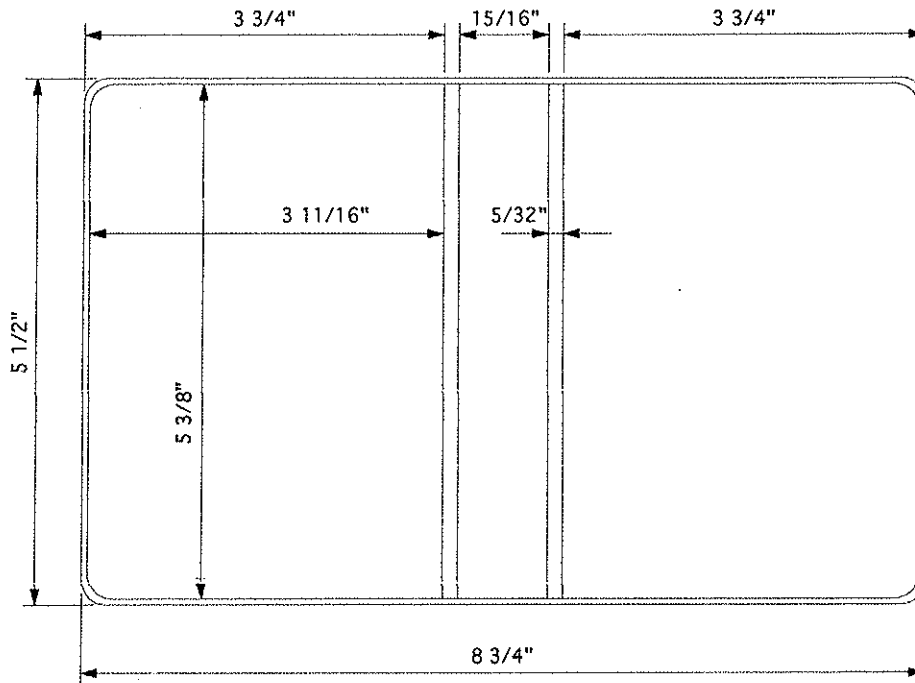

MATERIAL SPECS		GAUGE	PCS.	MATERIAL SPECS	GAUGE	PCS.
COVER MAT.	6 1/4 X 9 1/2		1	LINING MAT.	6 1/4 X 9 1/2	1
COVER MAT.				LINING MAT.		
DIE CUT				HORZ. PKT.		
COL				VERT. PKT.		
LABEL HOLDER				DIE CUT		
GUSSET				REINF.		
BOARD SPECS		GAUGE	PCS.	BOARD SPECS	GAUGE	PCS.
5/16" R. CORNERS				5/16" R. CORNERS		
F.C. BOARD	5 5/16 X 3 5/8	100	1	F.C. BOARD		
B.B. BOARD	5 5/16 X 27/32	100	1	B.B. BOARD		
B.C. BOARD	5 5/16 X 3 5/8	100	1	B.C. BOARD		
FLAP BD.				DIE CUT		
BOARD				DIE CUT		

DIE #	6992	METAL	6 RING MEMO W/B	RADIUS	3/8
ORDER #	376850	CUSTOMER	MILLENIUUM MARKETING	TEAR SEAL	.010
SHEET SIZE	5.375 x 7.875	STYLE CASE	VINYL PHOTO BINDER	BAR SEAL	48-3
CAP.	1"	DUE DATE	10-17-00	COMPLETED	
LOCATION		QUANTITY	3500	DATE	10-5-00

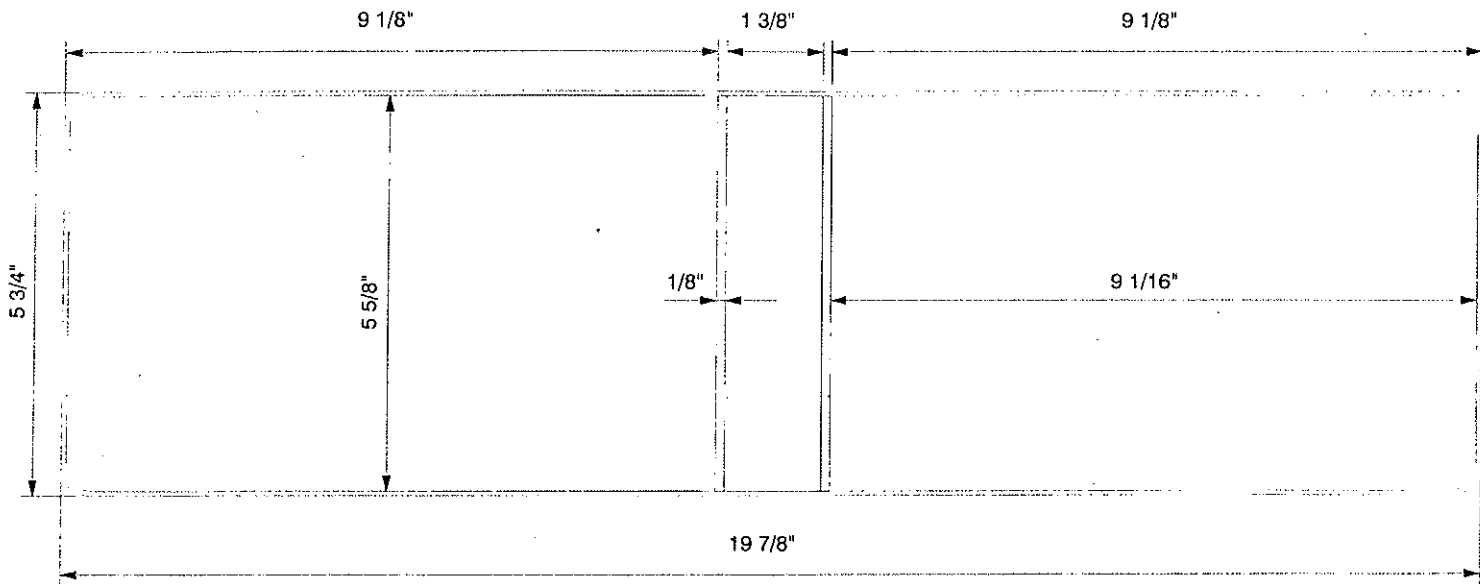

MATERIAL SPECS		GAUGE	PCS.	MATERIAL SPECS		GAUGE	PCS.
COVER MAT.	6 1/2 X 20 5/8		1	LINING MAT.	6 1/2 X 20 5/8		1
COVER MAT.				LINING MAT.			
DIE CUT				HORZ. PKT.			
COL				VERT. PKT.			
LABEL HOLDER				DIE CUT			
GUSSET				REINF.			
BOARD SPECS		5/16" R. CORNERS		GAUGE	PCS.	BOARD SPECS	
F.C. BOARD	5 9/16 X 9	100	1	F.C. BOARD			
B.B. BOARD	5 9/16 X 1 9/32	100	1	B.B. BOARD			
B.C. BOARD	5 9/16 X 9	100	1	B.C. BOARD			
FLAP BD.				DIE CUT			
BOARD				DIE CUT			

DIE # 7418
 ORDER # 550096
 SHEET SIZE 6 X 5
 CAP.
 LOCATION

METAL
 CUSTOMER EMBASSY SUITES
 STYLE CASE VINYL PAD
 DUE DATE 4-14-03
 QUANTITY 1000

RADIUS 3/8"
 TEAR SEAL
 BAR SEAL
 COMPLETED
 DATE 4-10-03

NELL DIE

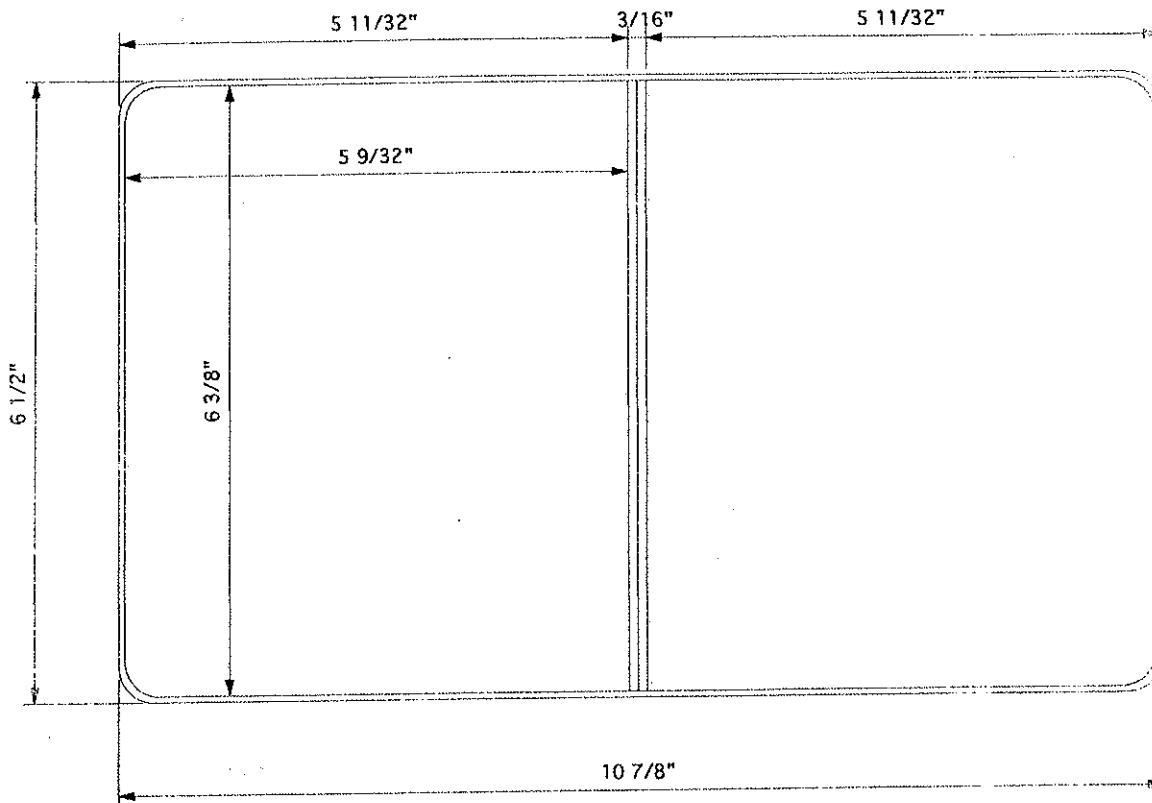

MATERIAL SPECS	GAUGE	PCS.	MATERIAL SPECS	GAUGE	PCS.		
COVER MAT.	7 1/4 X 11 5/8	1	LINING MAT.	7 1/4 X 11 5/8	1		
COVER MAT.			LINING MAT.				
DIE CUT			HORZ. PKT.				
COL			VERT. PKT.	7 1/4 X 4 3/8	2		
LABEL HOLDER			DIE CUT				
GUSSET			REINF.				
BOARD SPECS	3/16" X CORNERS	GAUGE	PCS.	BOARD SPECS	5/16" X CORNERS	GAUGE	PCS.
F.C. BOARD	6 5/16 X 5 7/32	100	1	F.C. BOARD			
B.B. BOARD				B.B. BOARD			
B.C. BOARD	6 5/16 X 5 7/32	100	1	B.C. BOARD			
FLAP BD.				DIE CUT			
BOARD				DIE CUT			

ITEM	7475	MATERIAL	MEMO	PAUSE	NONL
PRICE	562530	CUSTOMER	STEWARTS	TEAR SEAL	
QUANTITY	4 1/2 X 2 1/2	STYLE CASE	VINYL BINDER (NELL)	BAR SEAL	
UNIT	1/2"	DUE DATE	7-7-03	COMPLETED	
DESCRIPTION		QUANTITY	1000	DATE	6-20-03

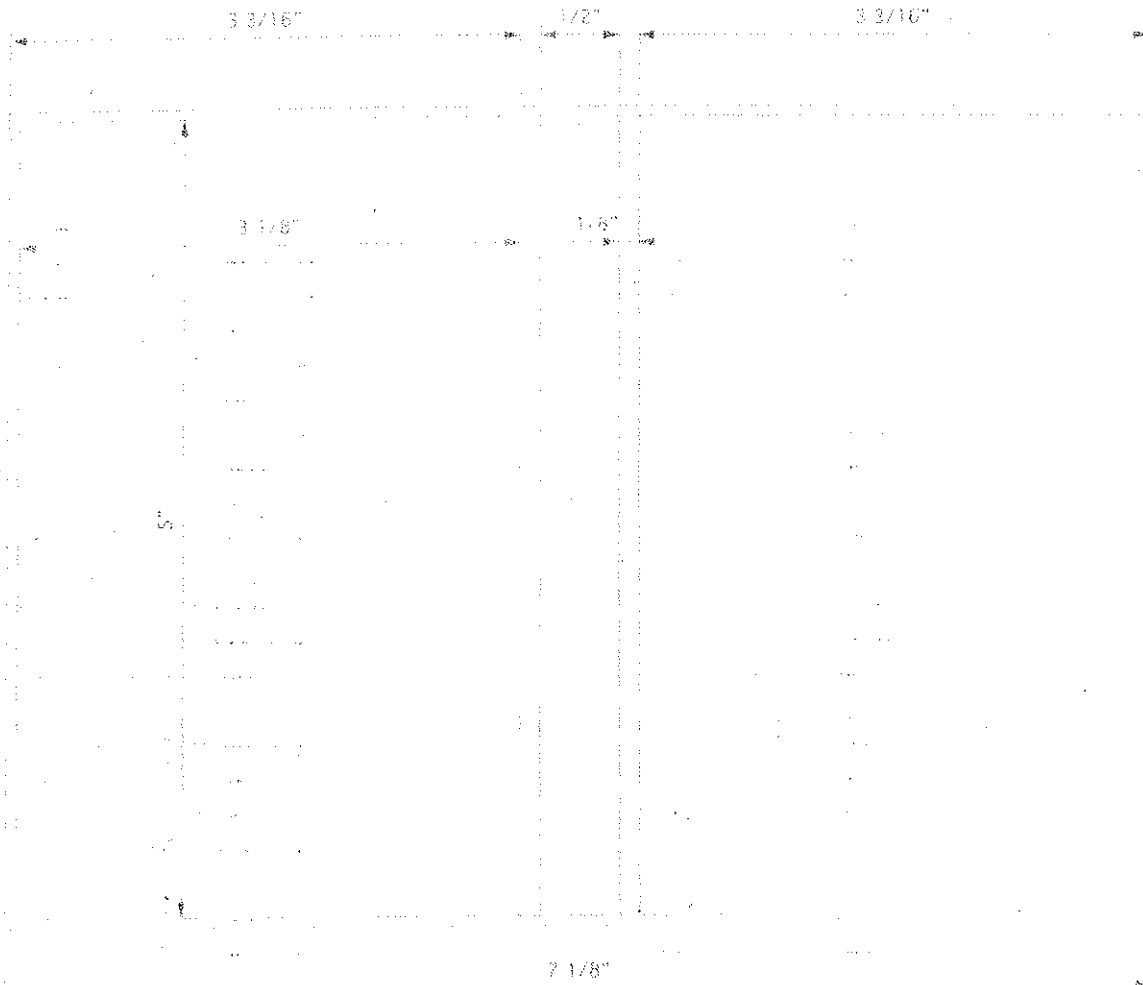

ITEM	QUANTITY	DESCRIPTION	UNIT	PRICE	TOTAL
COVER MAT.	1	6 1/8 X 8 1/8			
COVER MAT.	1	5 7/8 X 7 7/8			
DIE CUT		LINING MAT			
COIL		HORZ. PKT.			
LABEL HOLDER	1	5 7/8 X 2 3/3			
REINFORCING		DIE CUT			
PC BOARD	48	4 7/8 X 3			
PC BOARD	48	4 7/8 X 3			
DIE CUT		DIE CUT			
DIE CUT		DIE CUT			

DIE #	7577	METAL	MEMO	RADIUS	3/8"
ORDER #	586726	CUSTOMER	COLGATE-PALMOLIVE	TEAR SEAL	.012
SHEET SIZE	5 3/4 X 4 1/4	STYLE CASE	VRB (NELL SPECS)	BAR SEAL	178 RIB
CAP.	1/2"	DUE DATE	12-1-03	COMPLETED	
LOCATION		QUANTITY	300	DATE	11-13-03

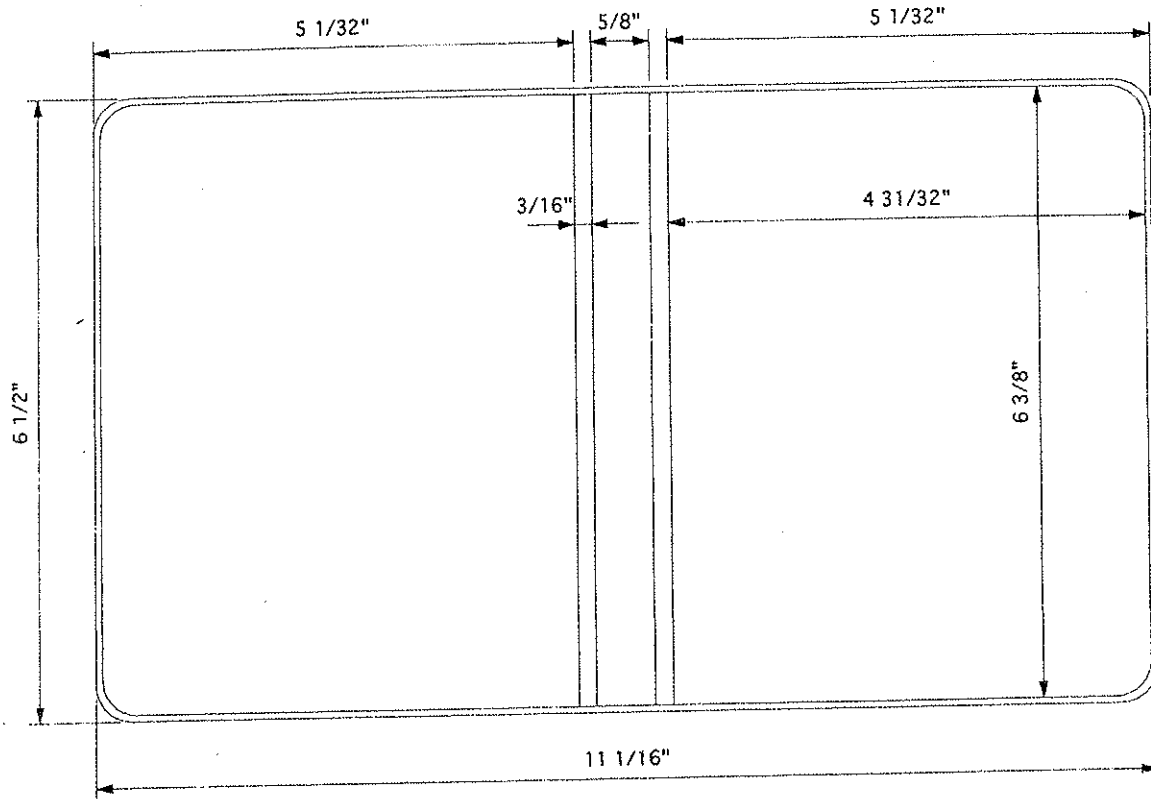

MATERIAL SPECS		GAUGE	PCS.	MATERIAL SPECS		GAUGE	PCS.
COVER MAT.	7 1/4 X 11 3/4		1	LINING MAT.	7 1/4 X 11 3/4		1
COVER MAT.				LINING MAT.			
DIE CUT				HORZ. PKT.	3 1/4 X 11 3/4		1
COL				VERT. PKT.			
LABEL HOLDER				DIE CUT			
GUSSET				REINF.			
BOARD SPECS		GAUGE	PCS.	BOARD SPECS		GAUGE	PCS.
F.C. BOARD	6 1/4 X 4 13/16	100	1	F.C. BOARD			
B.B. BOARD	6 1/4 X 1/2	100	1	B.B. BOARD			
B.C. BOARD	6 1/4 X 4 13/16	100	1	B.C. BOARD			
FLAP BD.				DIE CUT			
BOARD				DIE CUT			

DIE #	7703	METAL	2 RING STR D	RADIUS	3/8"
ORDER #	625801	CUSTOMER	TRY-FOODS INT'L	TEAR SEAL	.014
SHEET SIZE	5 1/2 X 5 7/8	STYLE CASE	VINYL BINDER	BAR SEAL	48-4
CAP.	1"	DUE DATE	6-25-04	COMPLETED	
LOCATION		QUANTITY	500	DATE	6-7-04

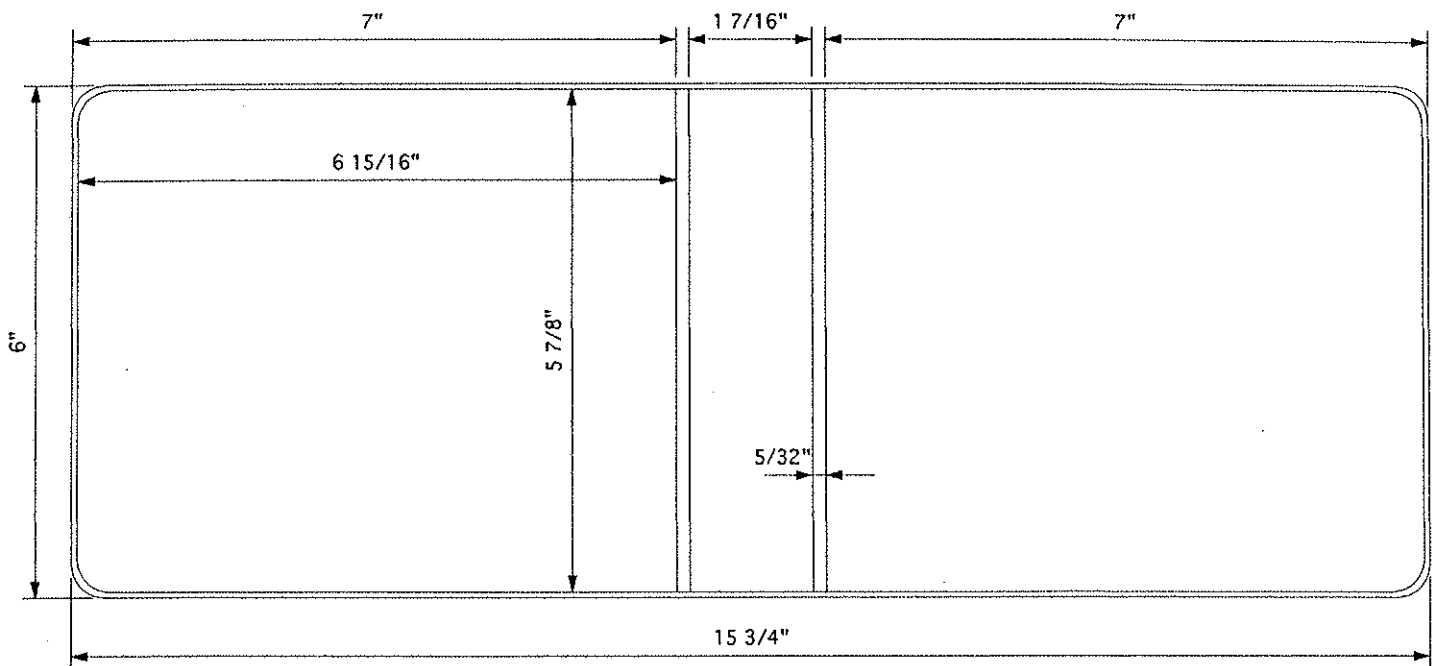

MATERIAL SPECS		GAUGE	PCS.	MATERIAL SPECS		GAUGE	PCS.				
COVER MAT.	6 3/4 X 16 1/2		1	LINING MAT.	6 3/4 X 16 1/2		1				
COVER MAT.	6 3/4 X 16 1/2		1	LINING MAT.							
DIE CUT				HORZ. PKT.							
COL				VERT. PKT.							
LABEL HOLDER				DIE CUT							
GUSSET				REINF.							
BOARD SPECS		5/16" R. CORNERS		GAUGE	PCS.	BOARD SPECS		5/16" R. CORNERS		GAUGE	PCS.
F.C. BOARD	5 25/32 X 6 27/32	100	1	F.C. BOARD							
B.B. BOARD	5 25/32 X 1 11/32	100	1	B.B. BOARD							
B.C. BOARD	5 25/32 X 6 27/32	100	1	B.C. BOARD							
FLAP BD.				DIE CUT							
BOARD				DIE CUT							

DIE #	8157	METAL	RR NB (2RING)	RADIUS	3/8"
ORDER #	739235	CUSTOMER	MERCURY PRINT	TEAR SEAL	.012
SHEET SIZE	6 X 4 1/2	STYLE CASE	VINYL DESK EASEL	BAR SEAL	253
CAP.	1 1/2"	DUE DATE	6-27-06	COMPLETED	
LOCATION		QUANTITY	570	DATE	6-19-06

*** WARNING DRAWING NOT ACTUAL SIZE ***

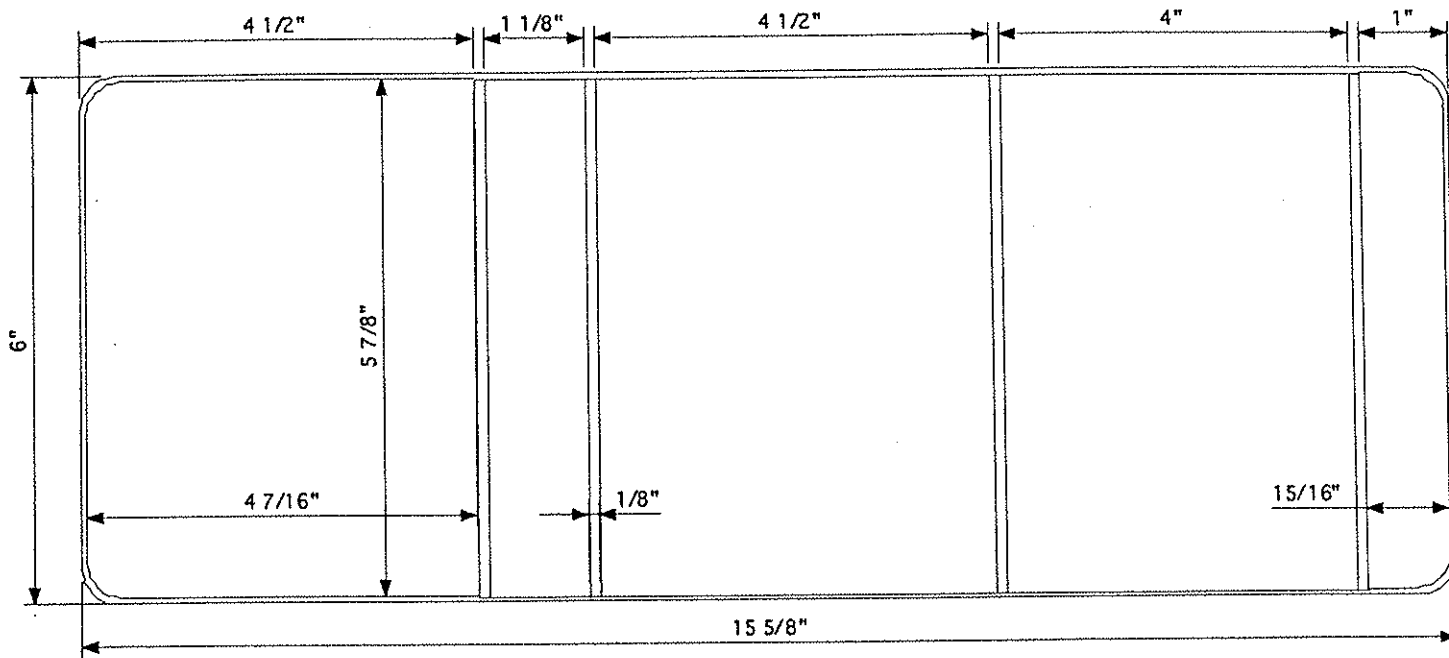

MATERIAL SPECS		GAUGE	PCS.	MATERIAL SPECS		GAUGE	PCS.
COVER MAT.	6 3/4 X 16 3/8		1	LINING MAT.	6 3/4 X 16 3/8		
COVER MAT.				LINING MAT.			
DIE CUT				HORZ. PKT.			
COL				VERT. PKT.			
LABEL HOLDER				DIE CUT			
GUSSET				REINF.			
BOARD SPECS		GAUGE	PCS.	BOARD SPECS		GAUGE	PCS.
5/16" R. CORNERS				5/16" R. CORNERS			
F.C. BOARD	5 13/16 X 4 3/8	100	1	F.C. BOARD			
B.B. BOARD	5 13/16 X 1 1/32	100	1	B.B. BOARD			
B.C. BOARD	5 13/16 X 4 7/16	100	1	B.C. BOARD			
FLAP BD.	5 13/16 X 27/32	100	1	DIE CUT			
BOARD				DIE CUT			

DIE #	8685	METAL	RR NB	RADIUS	3/8"
ORDER #	890365	CUSTOMER	MIKE CALVERT	TEAR SEAL	.014
SHEET SIZE	5 1/2 X 6	STYLE CASE	VRB W/CLEAR FRONT	BAR SEAL	43-4
CAP.	1/2"	DUE DATE	4-28-09	COMPLETED	
LOCATION		QUANTITY	5	DATE	4-20-09

*** WARNING DRAWING NOT ACTUAL SIZE ***

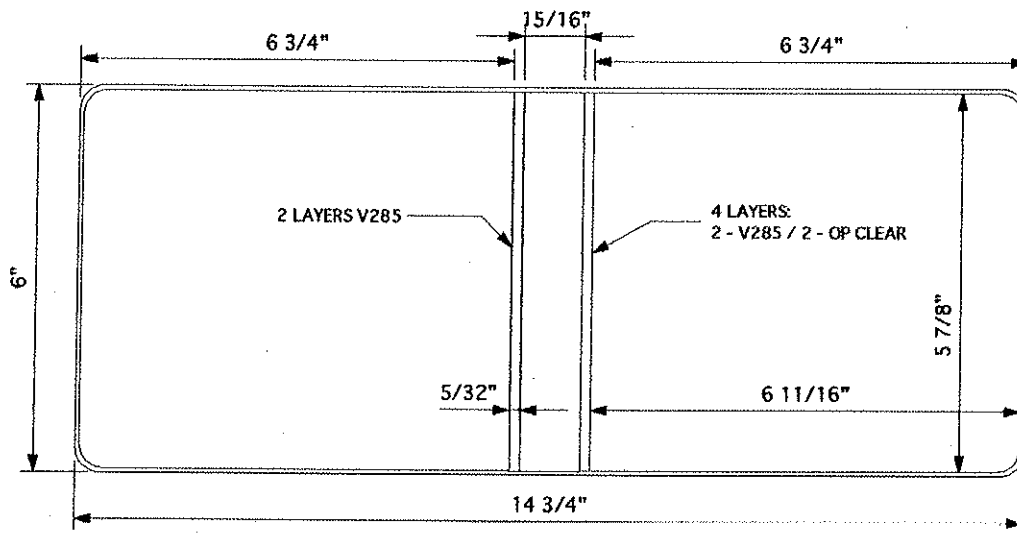

MATERIAL SPECS		GAUGE	PCS.	MATERIAL SPECS	GAUGE	PCS.	
COVER MAT.	6 3/4 X 8 3/8	V285	1	LINING MAT.	6 3/4 X 8 3/8	V285 1	
COVER MAT.	6 3/4 X 7 5/16	OP	1	LINING MAT.	11 1/4 X 7 5/16	OP 1	
DIE CUT				HORZ. PKT.			
COL.				VERT. PKT.			
LABEL HOLDER				DIE CUT			
GUSSET				REINF.			
BOARD SPECS	5/16" R. CORNERS	GAUGE	PCS.	BOARD SPECS	5/16" R. CORNERS	GAUGE	PCS.
F.C. BOARD	5 13/16 X 6 5/8	30GA CLEAR	1	F.C. BOARD			
B.B. BOARD	5 13/16 X 27/32	100	1	B.B. BOARD			
B.C. BOARD	5 13/16 X 6 5/8	100	1	B.C. BOARD			
FLAP BD.				DIE CUT			
BOARD				DIE CUT			