

Product Code

Style Case *Ring binder*

Sheet Size *6* X *3 3/4* Cap. *3/4* Die No. *2816* Order No. *18270-9* Plate

Customer

Dempster Systems

Metal
Total Vinyl <i>.030</i>
Quantity <i>50</i>
Date <i>5-21-82</i>
Type Corners <i>Rd</i>
Radius <i>7/32</i>
Completed

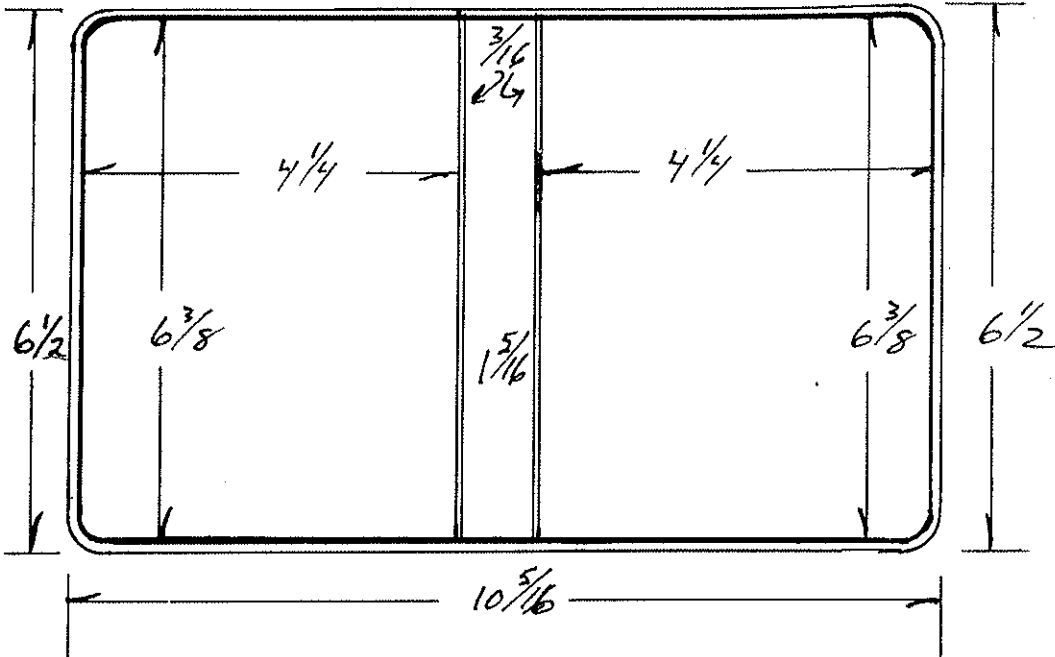

	Gauge	Thick
Tear Seal	<i>.016</i>	<i>7/32</i>
Bar Seal	<i>178</i>	<i>7/16</i>
Bar Seal		

	No. of Feet
Tear Seal	
Bar Seal	
Bar Seal	

Code	Ga.	# PCS	Cutting Specs		Code	Ga.	# Pcs.	Cutting Specs	
			Size	Out				Size	Out
Cover Mat.			<i>7 1/8 X</i>	<i>10 15/16</i>	Lining Mat.			<i>7 1/8 X</i>	<i>10 15/16</i>
Cover Mat			X		Lining Mat.			X	
Vert. Pckt.			X		Horz. Pckt.			X	
Vert. Pckt.			X		Horz. Pckt.			X	
Pocket			X		Pocket			X	
Label Holder			X		Card Holder			X	
Material			X		Material			X	
Material			X		Material			X	
Material			X		Material			X	
F.C. Board			<i>6 1/4 X</i>	<i>4 1/8</i>	B.C. Board			<i>6 1/4 X</i>	<i>4 1/8</i>
B.C. Board			X		B.B. Board			<i>6 1/4 X</i>	<i>1 3/16</i>
Center Board			X		Board			X	
Board			X		Strip			X	
Cover Pad			X		Strip			X	
					B.B. Pad			X	

Product Code

Style Case *Memo*

Sheet Size 6 X 3³/₄ Cap. 1 Die No. 3327 Order No. 948266 Plate

Customer

Royal order of Testers

Metal
Total Vinyl .024
Quantity 125
Date 5-10-85
Type Corners <i>Rd.</i>
Radius <i>3/32</i>
Completed

	Gauge	Thick
Tear Seal	.012	<i>3/32</i>
Bar Seal	178	<i>3/16</i>
Bar Seal		

	No. of Feet
Tear Seal	
Bar Seal	
Bar Seal	

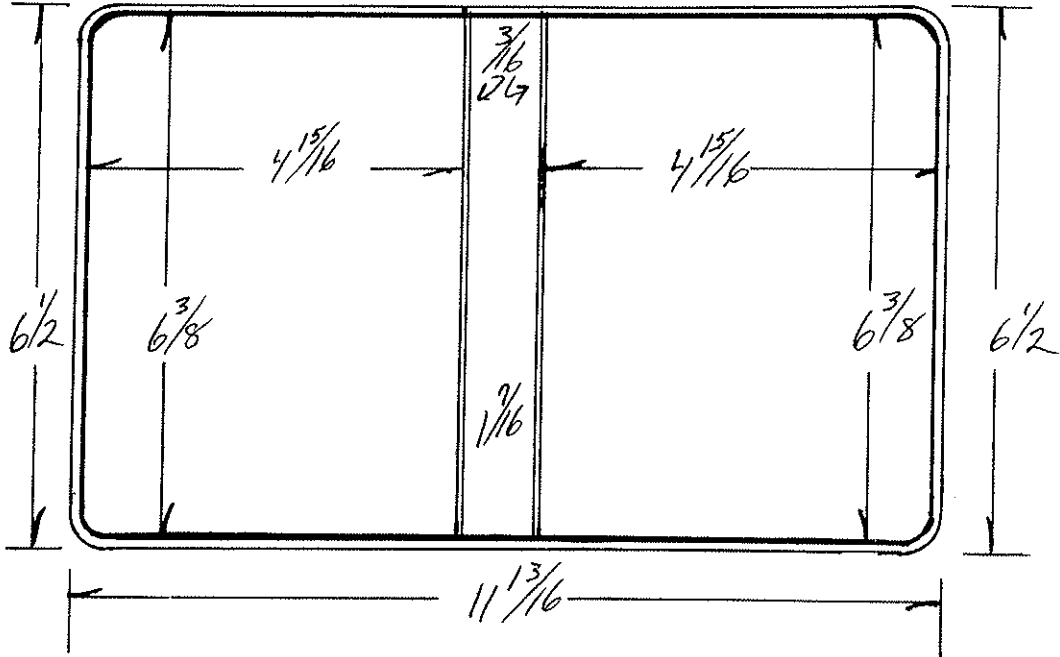

Code	Ga.	PCS	Cutting Specs		Code	Ga.	Pcs.	Cutting Specs	
			Size	Out				Size	Out
Cover Mat.			7 ¹ / ₈ X	12 ⁷ / ₁₆	Lining Mat.			7 ¹ / ₈ X	12 ⁷ / ₁₆
Cover Mat			X		Lining Mat.			X	
Vert. Pckt.			7 ¹ / ₈ X	2 ⁵ / ₁₆	Horz. Pckt.			X	
Vert. Pckt.			X		Horz. Pckt.			X	
Pocket			X		Pocket			X	
Label Holder			X		Card Hlder			X	
Material			X		Material			X	
Material			X		Material			X	
Material			X		Material			X	
F.C. Board			6 ¹ / ₄ X	4 ¹³ / ₁₆	B.C. Board			6 ¹ / ₄ X	4 ¹³ / ₁₆
B.C. Board			X		B.B. Board			6 ¹ / ₄ X	1 ⁵ / ₁₆
Center Board			X		Board			X	
Board			X		Strip			X	
Cover Pad			X		Strip			X	
					B.B. Pad			X	

Product Code

Style Case Ring Binder

Sheet Size 6 3/4 X 4 1/4

Cap. 3/4

Die No. 3432

Order No. 945568

Plate

Hirschfeld Press

Customer

Metal
Total Vinyl <u>.030</u>
Quantity <u>4000</u>
Date
Type Corners <u>RD</u>
Radius <u>1/4</u>
Completed

	Gauge	Thick
Tear Seal	<u>.016</u>	<u>3/32</u>
Bar Seal	<u>102</u>	<u>3/32</u>
Bar Seal		

	No. of Feet
Tear Seal	
Bar Seal	
Bar Seal	

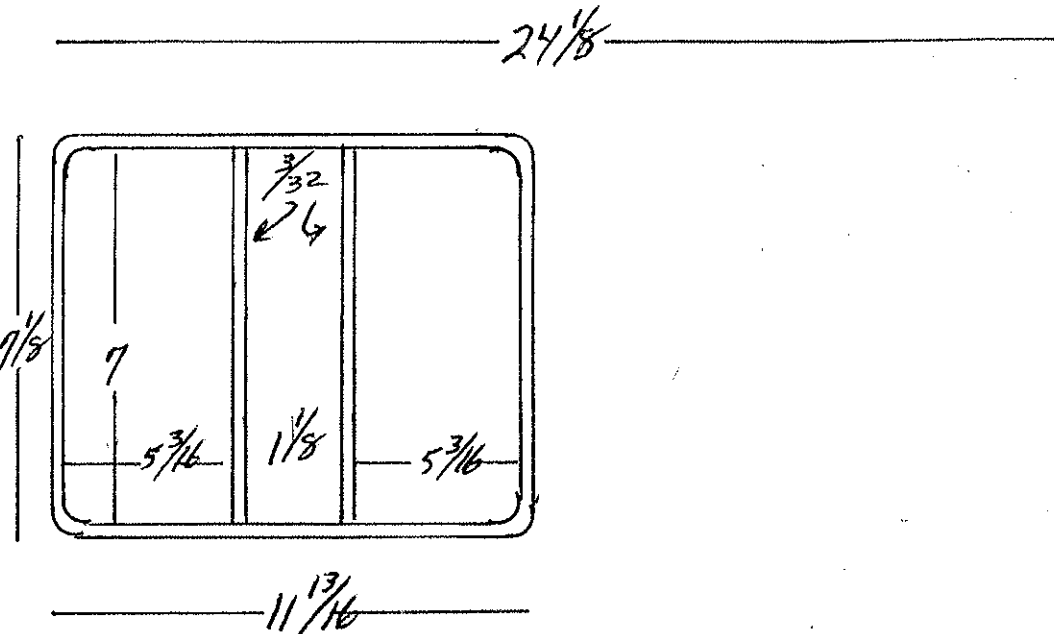

Code	Ga.	PCS	Cutting Specs.		Code	Ga.	Pcs.	Cutting Specs.	
			Size	Out				Size	Out
Cover Mat.			<u>7 3/4 X 12 1/2</u>	<u>1</u>	Lining Mat.			<u>7 3/4 X 12 1/2</u>	<u>1</u>
Cover Mat.			X		Lining Mat.			X	
Vert. Pckt.			X		Horz. Pckt.			X	
Vert. Pckt.			X		Horz. Pckt.			X	
Pocket			X		Pocket			X	
Label Holder			X		Card Holder			X	
Material			X		Material			X	
Material			X		Material			X	
Material			<u>6 29/32 X 5 3/32</u>		Material			X	
F.C. Board					B.C. Board				
B.C. Board			<u>6 29/32 X 5 3/32</u>		B.B. Board			<u>2</u>	
Center Board			X		Board			<u>6 29/32 X 1 1/32</u>	
Board			X		Strip			X	
Cover Pad			X		Strip			X	
					B.B. Pad			X	

RA ...

Product Code

old 1295

Style Case Memo

Sheet Size

6 3/4 X 3 3/4

Cap.

1/2

Die No. 3507

Order No. 951506

Plate

Customer

Provident Life + Accident

Metal
Total Vinyl .024
Quantity 100
Date 5-2-86
Type Corners Rd
Radius 1/4
Completed

	Gauge	Thick
Tear Seal	.012	3/32
Bar Seal	42	3/32
Bar Seal		

	No. of Feet
Tear Seal	
Bar Seal	
Bar Seal	

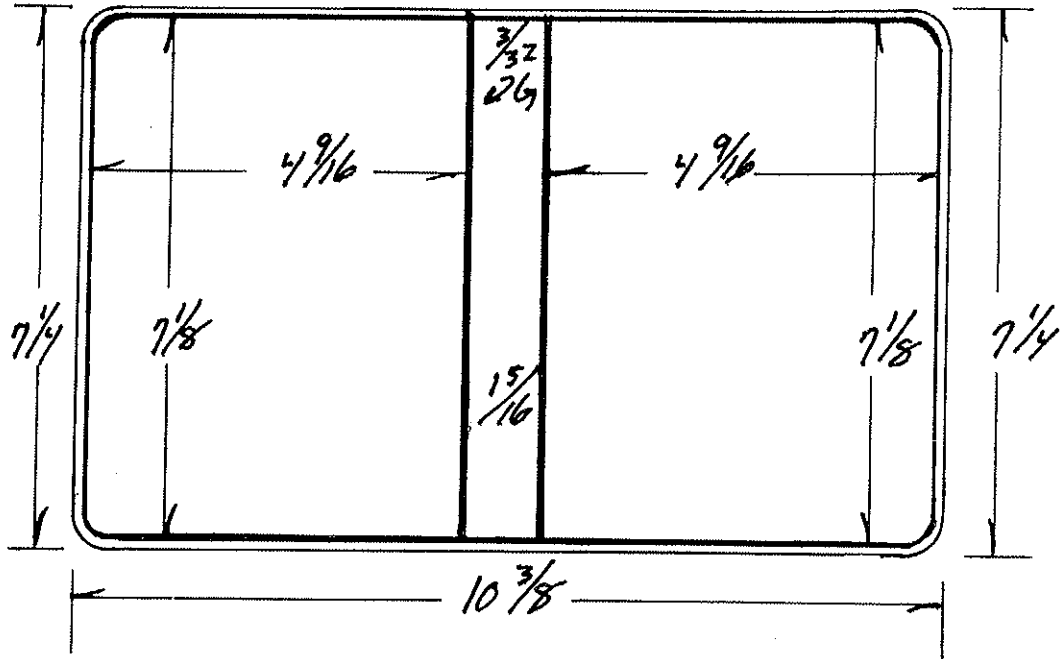

Code	Ga.	#	PCS	Cutting Specs		Code	Ga.	#	Pcs.	Cutting Specs	
				Size	Out					Size	Out
Cover Mat.			1	7 1/8 X	11	Lining Mat.			1	7 1/8 X	11
Cover Mat.				X		Lining Mat.				X	
Vert. Pckt.				X		Horz. Pckt.				X	
Vert. Pckt.				X		Horz. Pckt.				X	
Pocket				X		Pocket				X	
Label Holder				X		Card Holder				X	
Material				X		Material				X	
Material				X		Material				X	
Material				X		Material				X	
F.C. Board			1	7 1/32 X	4 7/16	B.C. Board			1	7 1/32 X	4 7/16
B.G. Board				X		B.B. Board			1	7 1/32 X	13/16
Center Board				X		Board				X	
Board				X		Strip				X	
Cover Pad				X		Strip				X	
						B.B. Pad				X	

Product Code as sample

Style Case MEMO

Sheet Size 6 3/4 X 4 3/4 Cap. 1/2 Die No. 3563 Order No. 952237 Plate

Customer

Central L.A. Electric

Metal
Total Vinyl <u>.030</u>
Quantity <u>250</u>
Date <u>7-16-86</u>
Type Corners <u>RD</u>
Radius <u>1/4</u>
Completed

	Gauge	Thick
Tear Seal	<u>.016</u>	<u>332</u>
Bar Seal	<u>102</u>	<u>332</u>
Bar Seal		

	No. of Feet
Tear Seal	
Bar Seal	
Bar Seal	

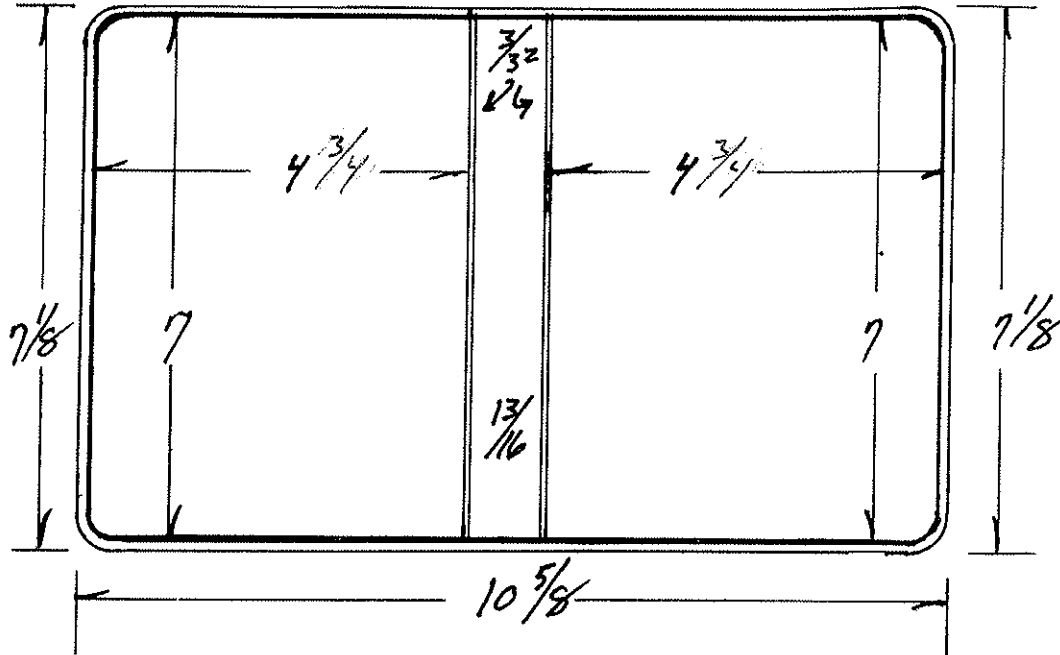

Code	Ga.	#	Cutting Specs		Code	Ga.	#	Cutting Specs	
			Size	Out				Size	Out
Cover Mat.			<u>7 3/4 X</u>	<u>11 3/8</u>	Lining Mat.			<u>7 3/4 X</u>	<u>11 3/8</u>
Cover Mat.			X		Lining Mat.			X	
Vert. Pckt.			X		Horz. Pckt.			X	
Vert. Pckt.			X		Horz. Pckt.			X	
Pocket			X		Pocket			X	
Label Holder			X		Card Hlder			X	
Material			X		Material			X	
Material			X		Material			X	
Material			X		Material			X	
F.C. Board			<u>6 15/16 X</u>	<u>4 11/16</u>	B.C. Board			<u>6 29/32 X</u>	<u>4 21/32</u>
B.C. Board			<u>6 17/16 X</u>	<u>4 11/16</u>	B.B. Board			<u>6 29/32 X</u>	<u>3 3/32</u>
Center Board			<u>6 15/16 X</u>	<u>2 3/32</u>	Board			<u>6 29/32 X</u>	<u>4 21/32</u>
Board			X		Strip			X	
Cover Pad			X		Strip			X	
					B.B. Pad			X	

Product Code

old Die
1295

Style Case Memo

Sheet Size $6\frac{3}{4}$ X $3\frac{3}{4}$ Cap. $\frac{1}{2}$

Die No. 3607

Order No. 952456

Plate

Customer

Provident Life + Accident

Metal
Total Vinyl .024
Quantity 250
Date 8-6-86
Type Corners RJ
Radius $\frac{1}{4}$
Completed

	Gauge	Thick
Tear Seal	.012	$\frac{3}{32}$
Bar Seal	.42	$\frac{3}{32}$
Bar Seal		

	No. of Feet
Tear Seal	
Bar Seal	
Bar Seal	

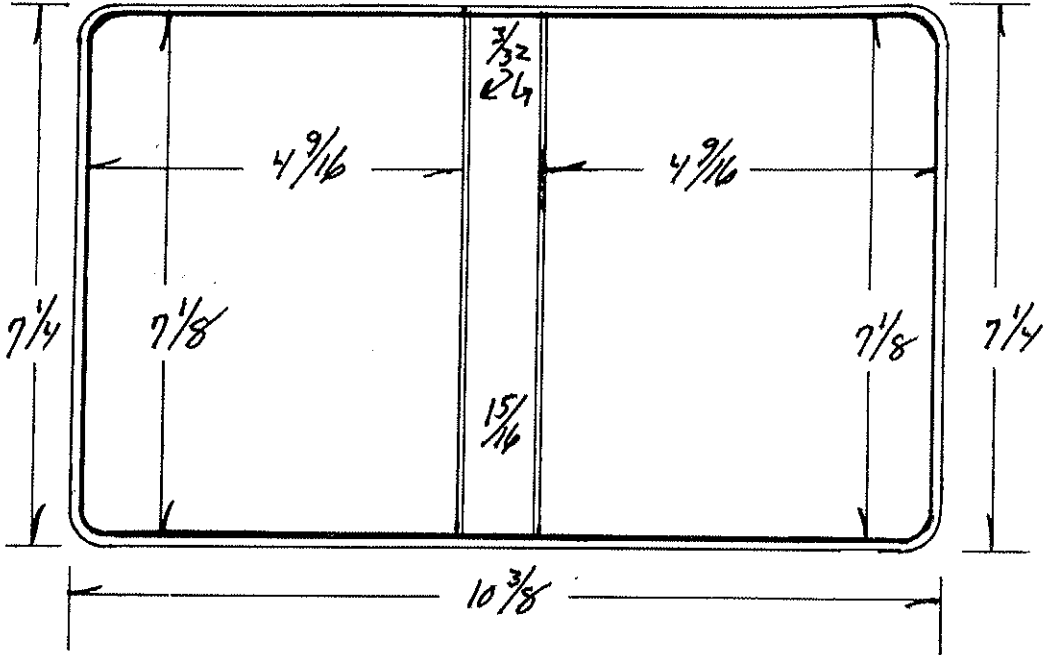

Code	Ga.	# PCS	Cutting Specs		Code	Ga.	# Pcs.	Cutting Specs	
			Size	Out				Size	Out
Cover Mat.			$7\frac{1}{8}$ X $11\frac{1}{8}$	1	Lining Mat.			$7\frac{1}{8}$ X $11\frac{1}{8}$	1
Cover Mat.			X		Lining Mat.			X	
Vert. Pckt.			X		Horz. Pckt.			X	
Vert. Rckt.			X		Horz. Pckt.			X	
Pocket			X		Pocket			X	
Label Holder			X		Card Holder			X	
Material			X		Material			X	
Material			X		Material			X	
Material			X		Material			X	
F.C. Board			$7\frac{1}{32}$ X $4\frac{15}{32}$	1	B.C. Board			$7\frac{1}{32}$ X $4\frac{15}{32}$	1
B.C. Board			X		B.B. Board			$7\frac{1}{32}$ X $2\frac{7}{32}$	1
Center Board			X		Board			X	
Board			X		Strip			X	
Cover Pad			X		Strip			X	
					B.B. Pad			X	

Product Code

Style Case *Ring Binder*

Sheet Size *6 3/4 X 3 1/4* Cap. *3/4* Die No. *3659* Order No. *953467* Plate

Customer

Transcolor

Metal
Total Vinyl <i>.030</i>
Quantity <i>500</i>
Date <i>11-10-86</i>
Type Corners <i>Rd</i>
Radius <i>3/8</i>
Completed

	Gauge	Thick
Tear Seal	<i>.016</i>	<i>3/32</i>
Bar Seal	<i>23</i>	<i>1/8</i>
Bar Seal		

	No. of Feet
Tear Seal	
Bar Seal	
Bar Seal	

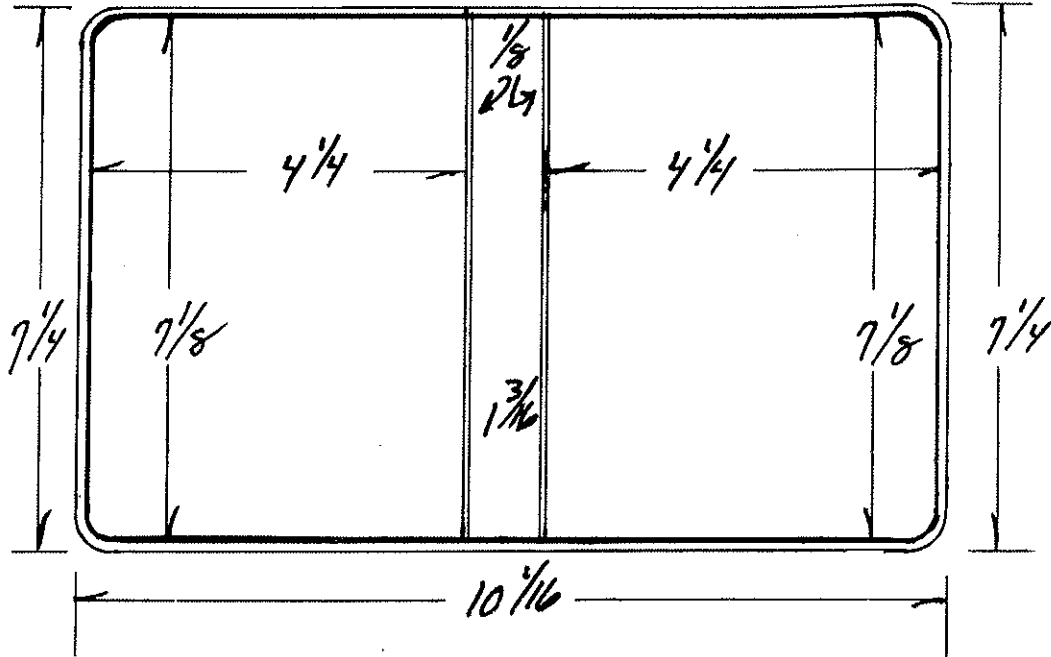

Code	Ga.	Pcs	Cutting Specs		Code	Ga.	Pcs	Cutting Specs	
			Size	Out				Size	Out
Cover Mat.		<i>1</i>	<i>7 7/8 X 10 1/16</i>		Lining Mat.		<i>1</i>	<i>7 7/8 X 10 1/16</i>	
Cover Mat.			X		Lining Mat.			X	
Vert. Pckt.			X		Horz. Pckt.			X	
Vert. Pckt.			X		Horz. Pckt.			X	
Pocket			X		Pocket			X	
Label Holder			X		Card Holder			X	
Material			X		Material			X	
Material			X		Material			X	
Material			X		Material			X	
F.C. Board		<i>1</i>	<i>7 1/16 X 4 3/16</i>		B.C. Board		<i>1</i>	<i>7 1/16 X 4 3/16</i>	
B.C. Board			X		B.B. Board		<i>1</i>	<i>7 1/16 X 1 1/8</i>	
Center Board			X		Board			X	
Board			X		Strip			X	
Cover Pad			X		Strip			X	
					B.B. Pad			X	

Product Code

Style Case **VRB**

Sheet Size **6 3/4 X 3 1/2** Cap. **1/2**

Die No. **3858**

Order No. **956334**

Plate

Customer **Riverside Press**

Metal
Total Vinyl
Quantity 1000
Date
Type Corners Rd
Radius 1/4
Completed

	Gauge	Thick
Tear Seal	16	3/32
Bar Seal	102	3/32
Bar Seal		

	No. of Feet
Tear Seal	
Bar Seal	
Bar Seal	

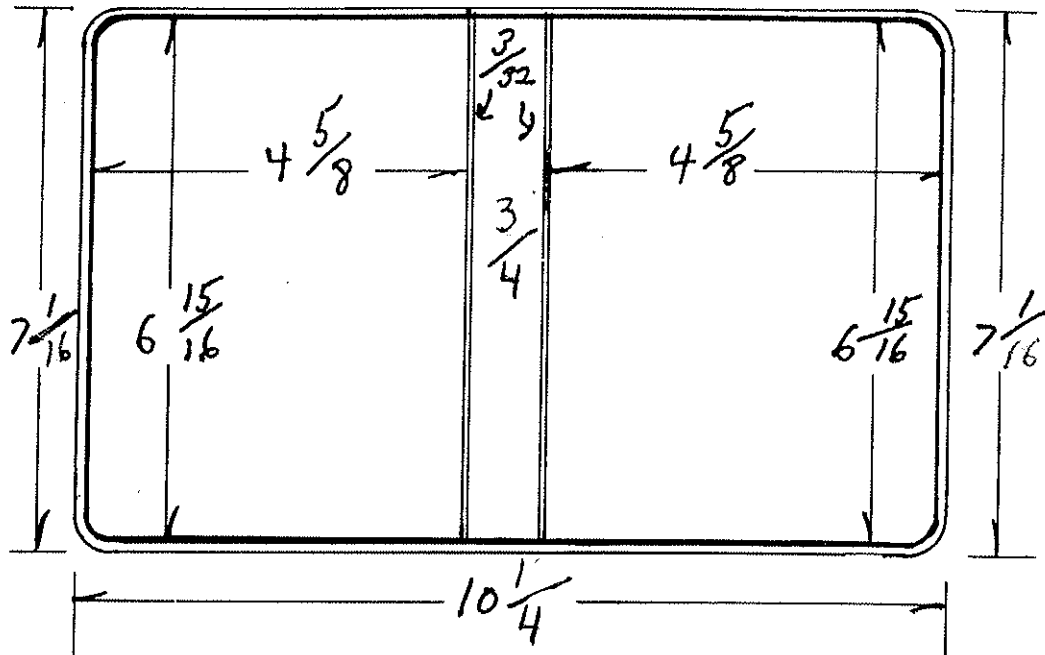

		Cutting Specs						Cutting Specs			
Code		Ga.	# PCS	Size	Out	Code		Ga.	# Pcs.	Size	Out
Cover Mat.	7 11/16 X 11		1			Lining Mat.	7 11/16 X 11		1		
Cover Mat.	X					Lining Mat.	X				
Vert. Pckt.	X					Horz. Pckt.	X				
Vert. Pckt.	X					Horz. Pckt.	X				
Pocket	X					Pocket	X				
Label Holder	X					Card Holder	X				
Material	X					Material	X				
Material	X					Material	X				
Material	X					Material	X				
F.C. Board	6 27/32 X 4 17/32	120	1			B.C. Board	6 27/32 X 4 17/32	120	1		
B.C. Board	6 7/8 X 4 9/16	100	2			B.B. Board	6 27/32 X 2 1/32	120	1		
Center Board	X					Board	6 7/8 X 2 1/32	100	1		
Board	X					Strip	X				
Cover Pad	X					Strip	X				
						B.B. Pad	X				

Product Code

Style Case VRB

Sheet Size 6 1/2 X 9 1/2 Cap. 1/2

Die No. 3928

Order No. 952345

Plate

Customer Damon

Metal
Total Vinyl
Quantity <u>200</u>
Date
Type Corners <u>Rd</u>
Radius <u>3/16</u>
Completed

	Gauge	Thick
Tear Seal	<u>1 pt</u>	<u>Edge</u>
Bar Seal	<u>253</u>	<u>1/8</u>
Bar Seal		

	No. of Feet
Tear Seal	
Bar Seal	
Bar Seal	

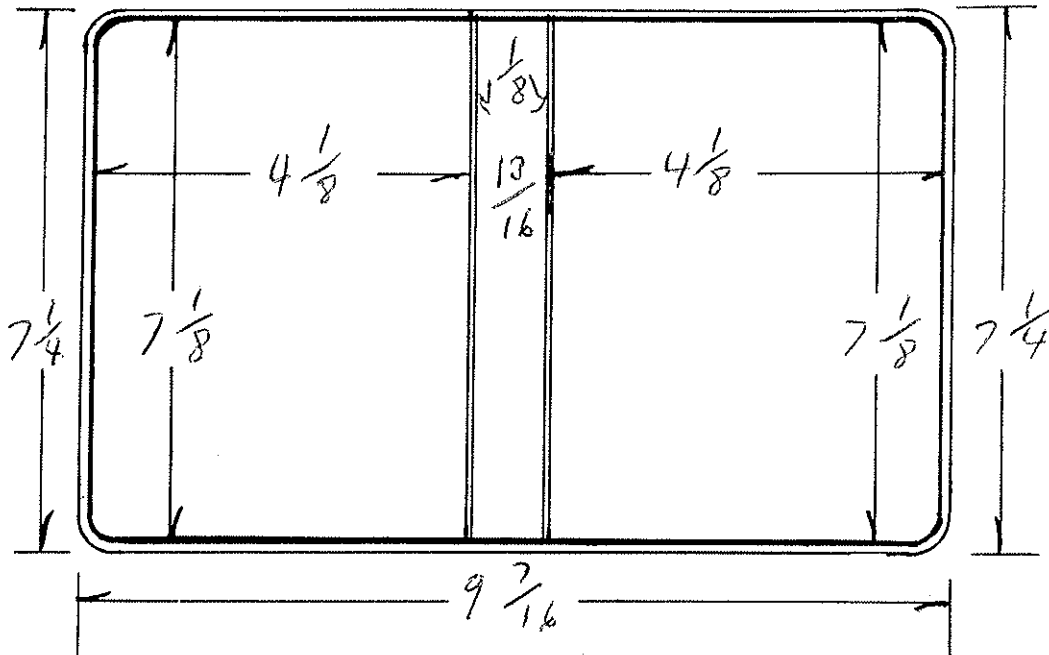

Code	Ga.	#	PCS	Cutting Specs		Code	Ga.	#	Pcs.	Cutting Specs	
				Size	Out					Size	Out
Cover Mat.					<u>7 7/8 X 10 1/16</u>	1	Lining Mat.				<u>7 7/8 X 10 1/16</u>
Cover Mat.					X		Lining Mat.				X
Vert. Pckt.					X		Horz. Pckt.				<u>3 7/8 X 4 5/8</u>
Vert. Pckt.					X		Horz. Pckt.				X
Pocket					X		Pocket				X
Label Holder					X		Card Holder				X
Material					X		Material				X
Material					X		Material				X
Material					X		Material				X
F.C. Board					<u>7 1/32 X 4 1/32</u>	1	B.C. Board				<u>7 1/32 X 4 1/32</u>
B.C. Board					X		B.B. Board				<u>7 1/32 X 23/32</u>
Center Board					X		Board				X
Board					X		Strip				X
Cover Pad					X		Strip				X
							B.B. Pad				X

Product Code Outside F.C. 7³/₈ x 3¹/₄

Style Case Memo Binder

Sheet Size 6³/₄ X 2¹/₂ Cap. 1/2 Die No. 3930

Order No. 957461 Plate

Customer

FIA Corp.

Metal
Total Vinyl <u>.030</u>
Quantity <u>1000</u>
Date
Type Corners <u>Rd</u>
Radius <u>1/4</u>
Completed

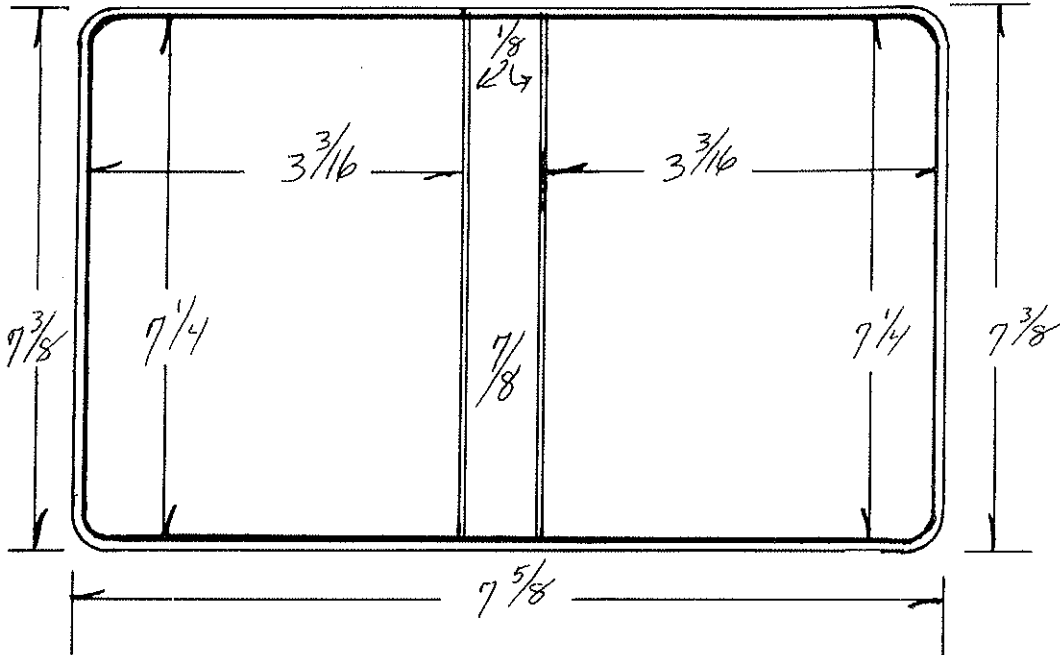

	Gauge	Thick
Tear Seal	<u>.016</u>	<u>3/32</u>
Bar Seal	<u>.253</u>	<u>1/8</u>
Bar Seal		

	No. of Feet
Tear Seal	
Bar Seal	
Bar Seal	

Code	Ga.	Pcs	Cutting Specs		Code	Ga.	Pcs	Cutting Specs	
			Size	Out				Size	Out
Cover Mat.		1	8 X 8 1/4		Lining Mat.		1	8 X 8 1/4	
Cover Mat			X		Lining Mat.			X	
Vert. Pckt.			X		Horz. Pckt.			X	
Vert. Pckt.			X		Horz. Pckt.			X	
Pocket			X		Pocket			X	
Label Holder			X		Card Holder			X	
Material			X		Material			X	
Material			X		Material			X	
Material			X		Material			X	
F.C. Board		1	7 3/16 X 3 1/8		B.C. Board		1	7 3/16 X 3 1/8	
B.C. Board			X		B.B. Board		1	7 3/16 X 1 3/16	
Center Board			X		Board			X	
Board			X		Strip			X	
Cover Pad			X		Strip			X	
					B.B. Pad			X	

Product Code

Style Case

Memo

Sheet Size $6\frac{3}{4}$ X $4\frac{3}{4}$ Cap. $\frac{3}{4}$ Die No. 3931 Order No. 957531 Plate

Customer

TESCO/TU Electric

Metal
Total Vinyl .030
Quantity 50
Date 12-23-87
Type Corners Rd
Radius $\frac{1}{4}$
Completed

	Gauge	Thick
Tear Seal	.016	$\frac{3}{32}$
Bar Seal	102	$\frac{3}{32}$
Bar Seal		

	No. of Feet
Tear Seal	
Bar Seal	
Bar Seal	

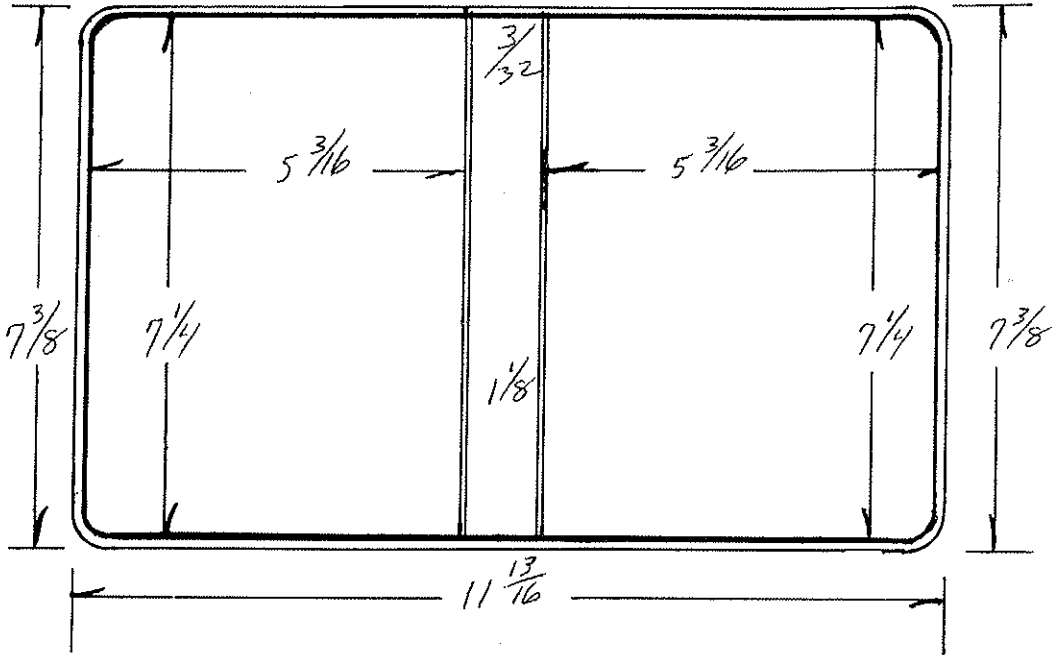

Code	Ga.	#	PCS	Cutting Specs		Code	K.P.D.	Ga.	#	Pcs.	Size	Ou
				Size	Out							
Cover Mat.						Lining Mat.						
Cover Mat.						Lining Mat.						
Vert. Pckt.						Horz. Pckt.						
Vert. Rckt.						Horz. Pckt.						
Pocket						Pocket						
Label Holder						Card Holder						
Material						Material						
Material						Material						
Material						Material						
F.C. Board						B.C. Board						
B.C. Board						B.B. Board						
Center Board						Board						
Board						Strip						
Cover Pad						Strip						
						B.B. Pad						

DIE #	4092-R	METAL	MEMO	RADIUS	3/8"
ORDER #	960655	CUSTOMER	DEPT OF NATURAL RES.	TEAR SEAL	.012
SHEET SIZE	6 x 4	STYLE CASE	VINYL BINDER	BAR SEAL	102
CAP.	1/2"	DUE DATE	11-1-88	COMPLETED	
LOCATION		QUANTITY	50	DATE	10-23-01

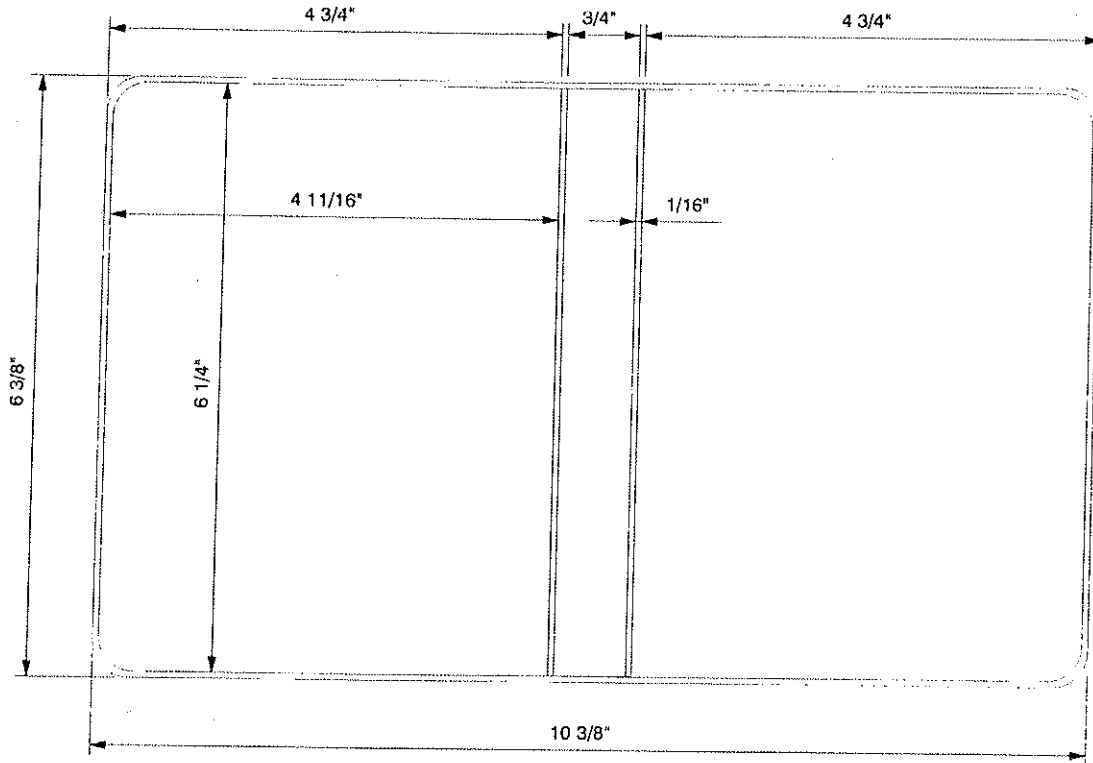

MATERIAL SPECS		GAUGE	PCS.	MATERIAL SPECS		GAUGE	PCS.
COVER MAT.	7 1/8 X 11 1/8		1	LINING MAT.	7 1/8 X 11 1/8		1
COVER MAT.				LINING MAT.			
DIE CUT				HORZ. PKT.	7 1/8 X 2 7/8		1
COL				VERT. PKT.			
LABEL HOLDER				DIE CUT			
GUSSET				REINF.			
BOARD SPECS		5/16" R. CORNERS		GAUGE	PCS.	BOARD SPECS	
F.C. BOARD	6 3/16 X 4 5/8	100	1	F.C. BOARD			
B.B. BOARD	6 3/16 X 21/32	100	1	B.B. BOARD			
B.C. BOARD	6 3/16 X 4 5/8	100	1	B.C. BOARD			
FLAP BD.				DIE CUT			
BOARD				DIE CUT			

Product Code

Style Case *VRB*

Sheet Size *6 3/4* X *4 1/4* Cap. *1/2* Die No. *4094*

Order No. *960626.1* Plate

Customer

Metal
Total Vinyl
Quantity
Date
Type Corners
Radius
Completed

	Gauge	Thick
Tear Seal	<i>.016</i>	<i>3/32</i>
Bar Seal	<i>.042</i>	
Bar Seal		

	No. of Feet
Tear Seal	
Bar Seal	
Bar Seal	

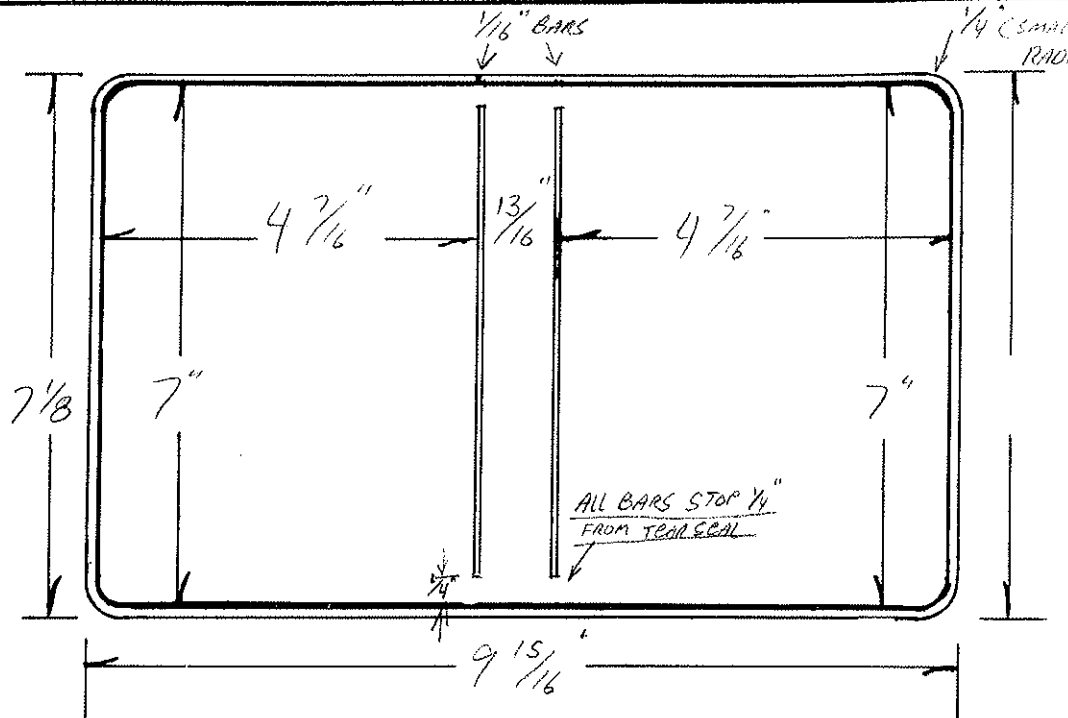

Code	Ga.	Pcs	Cutting Specs		Code	Ga.	Pcs	Cutting Specs	
			Size	Out				Size	Out
Cover Mat.		<i>10 3/4</i> X <i>7 7/8</i>	<i>15</i>	<i>1</i>	Lining Mat.		<i>10 3/4</i> X <i>7 7/8</i>	<i>15</i>	<i>1</i>
Cover Mat.		X			Lining Mat.		X		
Vert. Pckt.		X			Horz. Pckt.		X		
Vert. Pckt.		X			Horz. Pckt.		X		
Pocket		X			Pocket		X		
Label Holder		X			Card Holder		X		
Material		X			Material		X		
Material		X			Material		X		
Material		X			Material		X		
F.C. Board		<i>6 15/16</i> X <i>4 3/8</i>	<i>100</i>	<i>1</i>	B.C. Board		X		
B.C. Board		<i>6 15/16</i> X <i>4 3/8</i>	<i>100</i>	<i>1</i>	B.B. Board		<i>6 15/16</i> X <i>2 3/32</i>	<i>100</i>	<i>1</i>
Center Board		X			Board		X		
Board		X			Strip		X		
Cover Pad		X			Strip		X		
					B.B. Pad		X		

Product Code

Style Case **VRB**

Sheet Size **6** X **3³/₄** Cap. **1/2** Die No. **4239**

Order No. **963044** Plate

Customer

ETHICON INC.

Metal
Total Vinyl
Quantity 200
Date 7-11-89
Type Corners RND
Radius 1/4"
Completed

	Gauge	Thick
Tear Seal	016	7/32
Bar Seal	#253	1/8
Bar Seal		

	No. of Feet
Tear Seal	
Bar Seal	
Bar Seal	

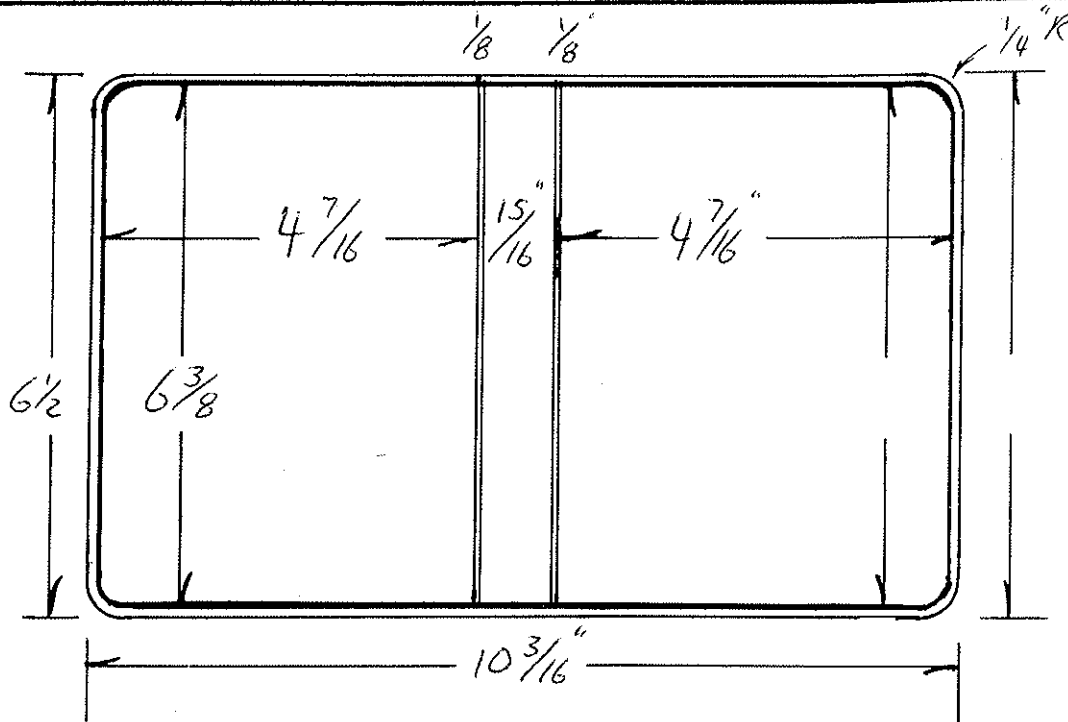

Code	Ga.	# PCS	Cutting Specs		Code	Ga.	# Pcs.	Cutting Specs	
			Size	Out				Size	Out
Cover Mat.					Lining Mat.				
	7¹/₄ X 11	15	1			7¹/₄ X 11	15	1	
Cover Mat	X				Lining Mat.	X			
Vert. Pckt.	X				Horz. Pckt.	X			
Vert. Pckt.	X				Horz. Pckt.	X			
Pocket	X				Pocket	X			
Label Holder	X				Card Holder	X			
Material	X				Material	X			
Material	X				Material	X			
Material	X				Material	X			
F.C. Board	6⁹/₃₂ X 4¹/₃₂	100	1		B.C. Board	X			
B.C. Board	6⁹/₃₂ X 4¹/₃₂	100	1		B.B. Board	6⁹/₃₂ X 2⁷/₃₂	100	1	
Center Board	6⁵/₁₆ X 4³/₈	100	2		Board	X			
Board	6⁵/₁₆ X 2⁷/₃₂	100	1		Strip	X			
Cover Pad	X				Strip	X			
					B.B. Pad	X			

Product Code

Style Case **VRB**

Sheet Size **6³/₄ X 4**

Cap. **1¹/₄"** Die No. **4305**

Order No. **968533**

Plate

Customer

FLORENCE KIWANIS CLUB

Metal
Total Vinyl
Quantity 50
Date 10-19-89
Type Corners
Radius 3/8"
Completed 10-20-89 RCT

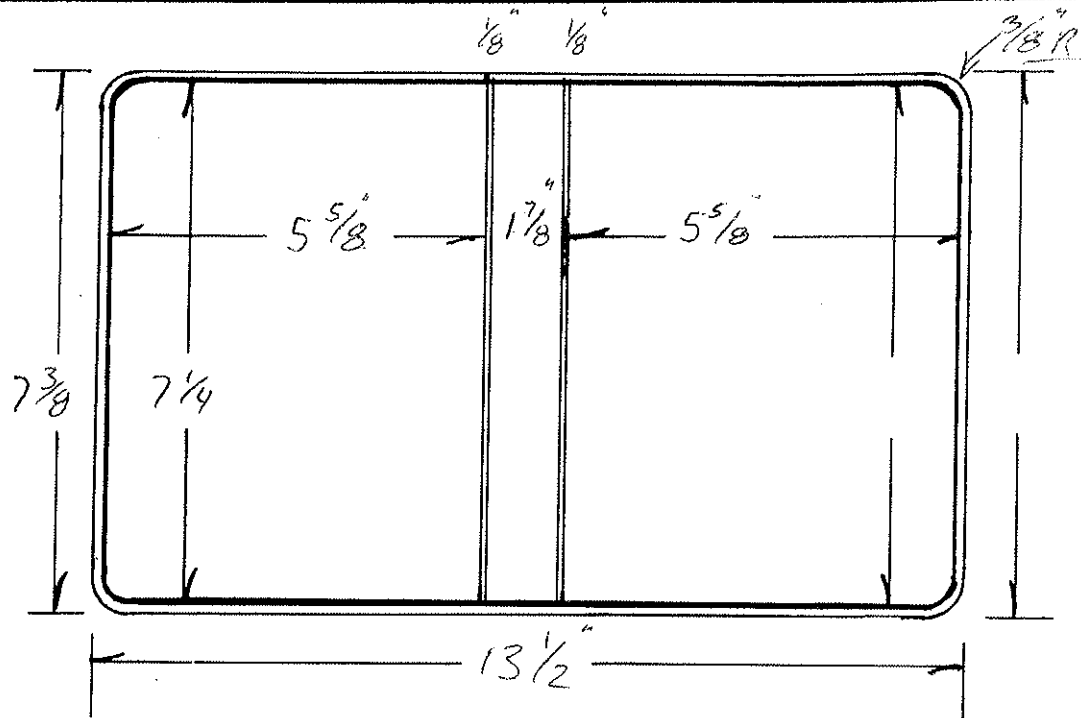

	Gauge	Thick
Tear Seal	.014	1/16
Bar Seal	#253	1/16
Bar Seal		

	No. of Feet
Tear Seal	
Bar Seal	
Bar Seal	

10-20
SIZE BY B.P. ✓
CHECK BY JJC

Code	Ga.	PCS	Cutting Specs		Code	Ga.	Pcs.	Cutting Specs	
			Size	Out				Size	Out
Cover Mat.			8 1/4 X	14 1/4	Lining Mat.			8 1/4 X	14 1/4
Cover Mat			X		Lining Mat.			X	
Vert. Pckt.			X		Horz. Pckt.			X	
Vert. Pckt.			X		Horz. Pckt.			X	
Pocket			X		Pocket			X	
Label Holder			X		Card Holder			X	
Material			X		Material			X	
Material			X		Material			X	
Material			X		Material			X	
F.C. Board			7 3/32 X	5 17/32	B.C. Board			X	
B.C. Board			7 3/32 X	5 17/32	B.B. Board			7 3/32 X	1 25/32
Center Board			X		Board			X	
Board			X		Strip			X	
Cover Pad			X		Strip			X	
					B.B. Pad			X	

Product Code

ULD # 2230

Style Case

VRB.

Sheet Size 6 3/4 x 4 1/4 Cap. 1

Die No. 4325

Order No. 964088

Plate

Customer

CORPORATE PRINTERS

Metal
Total Vinyl
Quantity
Date 11-16-89
Type Corners
Radius
Completed

	Gauge	Thick
Tear Seal	.012"	1/16
Bar Seal	#102	1/16
Bar Seal		

	No. of Feet
Tear Seal	
Bar Seal	
Bar Seal	

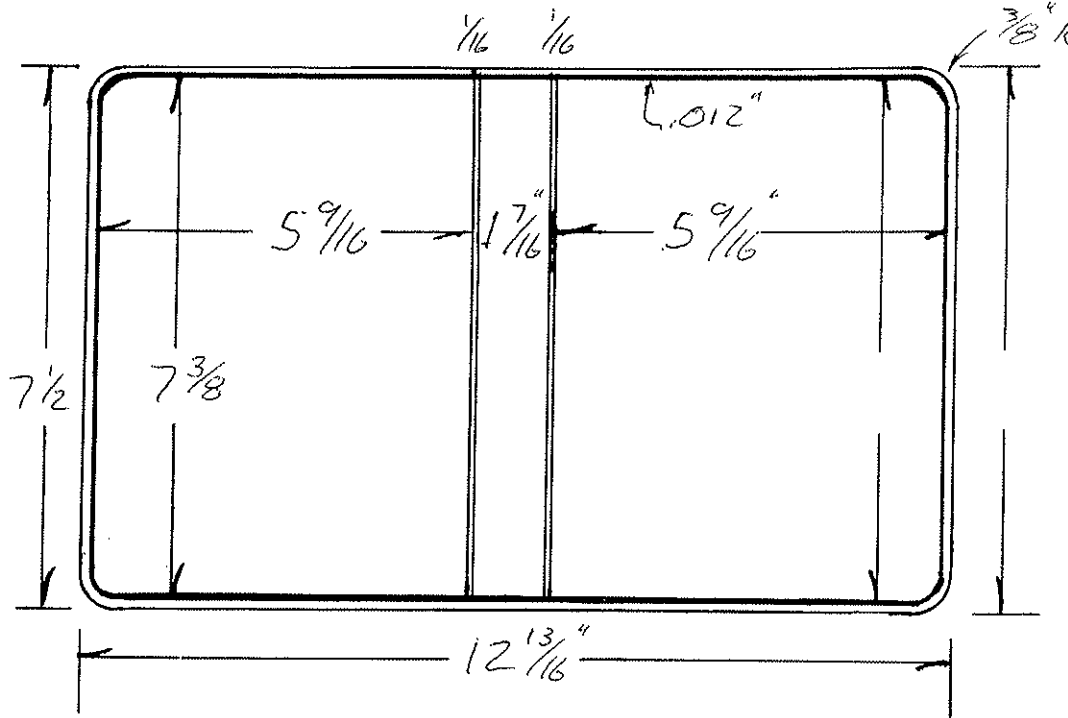

SIZE BY: B.P.

CHECK BY: *K.P.*

Code	Ga.	#	Cutting Specs		Code	Ga.	#	Cutting Specs			
			Size	Out				Size	Out		
Cover Mat.			8 1/4 x 13 5/8	15	1	Lining Mat.			8 1/4 x 13 5/8	15	1
Cover Mat.			X			Lining Mat.			X		
Vert. Pckt.			X			Horz. Pckt.			X		
Vert. Pckt.			X			Horz. Pckt.			X		
Pocket			X			Pocket			X		
Label Holder			X			Card Holder			X		
Material			X			Material			X		
Material			X			Material			X		
Material			X			Material			X		
F.C. Board			7 9/32 x 5 15/32	100	1	B.C. Board			X		
B.C. Board			7 9/32 x 5 15/32	100	1	B.B. Board			7 9/32 x 1 1/32	100	1
Center Board	1/16"		7 5/16 x 5 1/2	100	2	Board			7 5/16 x 1 1/32		1
Board			X			Strip			X		
Cover Pad			X			Strip			X		
						B.B. Pad			X		

Product Code

06042341

Style Case

VRB

Sheet Size

6 3/4 x 4 3/4

Cap. 1/2

Die No. 4395

Order No. 965069

Plate

Customer

NEW HAMPSHIRE HORSE & TRAIL

Metal
Total Vinyl
Quantity
Date 3-14-90
Type Corners
Radius
Completed

	Gauge	Thick
Tear Seal	014	1/16"
Bar Seal	102	1/16"
Bar Seal		

	No. of Feet
Tear Seal	
Bar Seal	
Bar Seal	

Size - B.P.

Check - J.M.

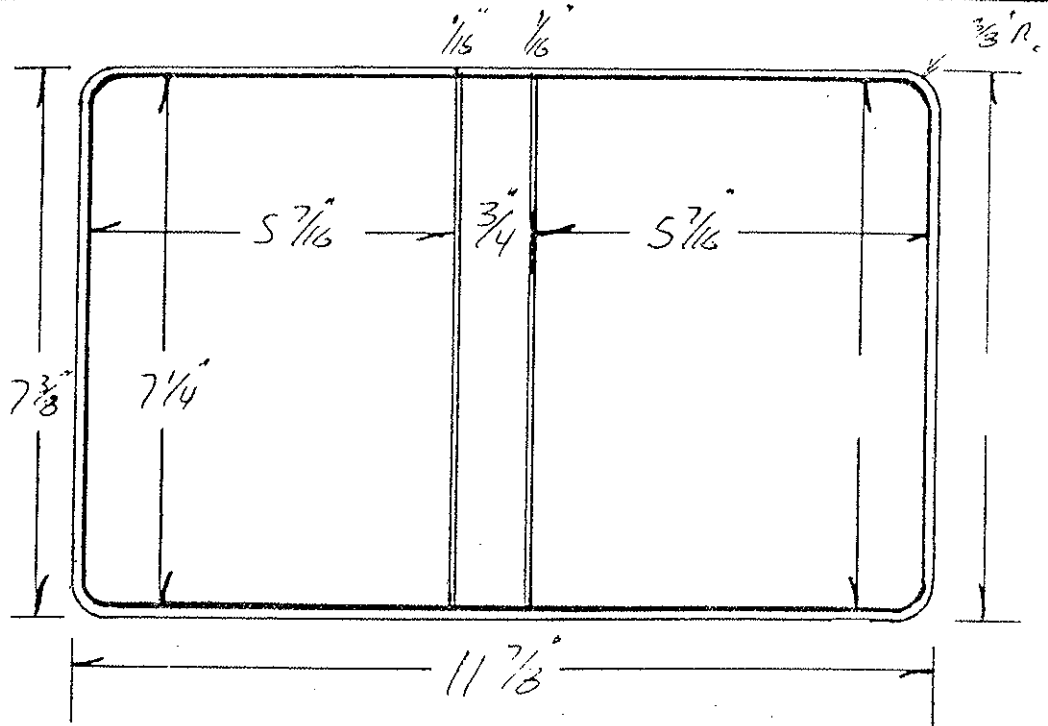

Code	Ga.	PCS	Cutting Specs		Code	Ga.	Pcs.	Cutting Specs	
			Size	Out				Size	Out
Cover Mat.	8 1/8	15	1		Lining Mat.	8 1/8	15	1	
Cover Mat	X				Lining Mat.	X			
Vert. Pckt.	X				Horz. Pckt.	X			
Vert. Pckt.	X				Horz. Pckt.	X			
Pocket	X				Pocket	X			
Label Holder	X				Card Holder	X			
Material	X				Material	X			
Material	X				Material	X			
Material	X				Material	X			
F.C. Board	7 7/32	100	1		B.C. Board	7 7/32	100	1	
B.C. Board	7 7/32	100	1		B.B. Board	7 7/32	100	1	
Center Board	X				Board	X			
Board	7 3/16	100	2		Strip	X			
Cover Pad	7 3/16	100	1		Strip	X			
					B.B. Pad	X			

DIE #	4533	METAL	1/2 MEMO	RADIUS	3/8"
ORDER #	966598	CUSTOMER	B'HAM COUNTRY CLUB	TEAR SEAL	.014
SHEET SIZE	6 3/4 X 4 3/4	STYLE CASE	VINYL RING BINDER	BAR SEAL	102
CAP.	1/2	DUE DATE		COMPLETED	
LOCATION	C-6-5	QUANTITY		DATE	1-22-96

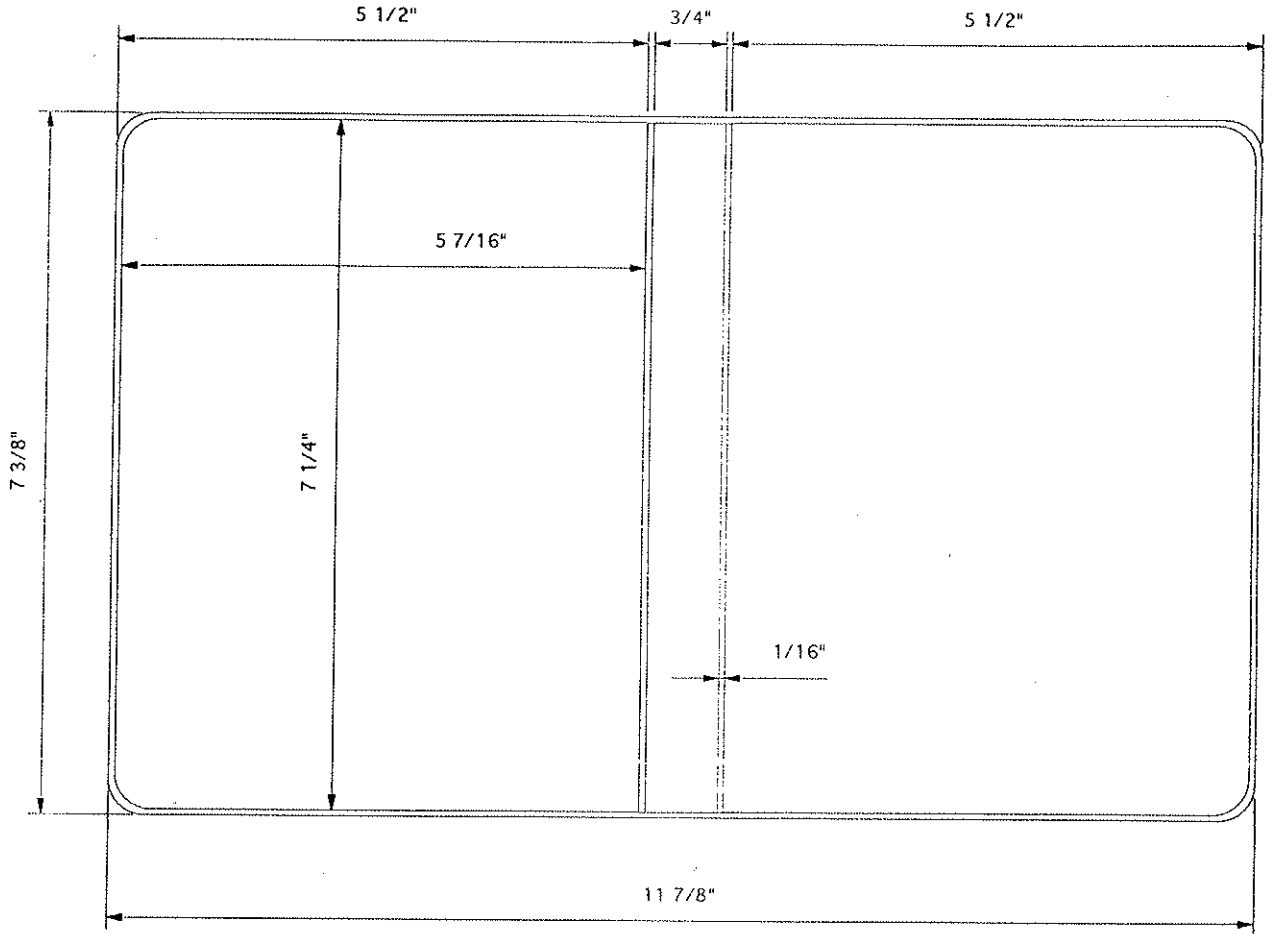

MATERIAL SPECS		GAUGE		MATERIAL SPECS		GAUGE	
COVER MAT.	8 1/8 X 12 5/8		1	LINING MAT.	8 1/8 X 12 5/8		1
COVER MAT.				LINING MAT.			
DIE CUT				HORZ. PKT.			
COL				VERT. PKT.			
LABEL HOLDER				DIE CUT			
GUSSET				REINF.			

BOARD SPECS		GAUGE		BOARD SPECS		GAUGE	
F.C. BOARD	7 3/16 X 5 3/8	100	1	F.C. BOARD	7 5/32 X 5 11/32	120	1
B.B. BOARD	7 3/16 X 21/32	100	1	B.B. BOARD	7 5/32 X 21/32	120	1
B.C. BOARD	7 3/16 X 5 3/8	100	1	B.C. BOARD	7 5/32 X 5 11/32	120	1
B.U. STRIP				DIE CUT			
DIE CUT				DIE CUT			

Product Code

Style Case URB / HANDBOOK 1/2 L00

Sheet Size 6 1/2 x 4

Cap. 1/2

Die No. 4556

Order No. 966637

Plate

Customer

BESCO OFFICE PRODUCTS

Metal
Total Vinyl
Quantity <u>500</u>
Date <u>9/20 10-2-90</u>
Type Corners
Radius <u>3/8"</u>
Completed

	Gauge	Thick
Tear Seal	<u>#253</u>	<u>1/8</u>
Bar Seal	<u>#014</u>	<u>1/16</u>
Bar Seal		

	No. of Feet
Tear Seal	
Bar Seal	
Bar Seal	

SIZE: B.P

Check-

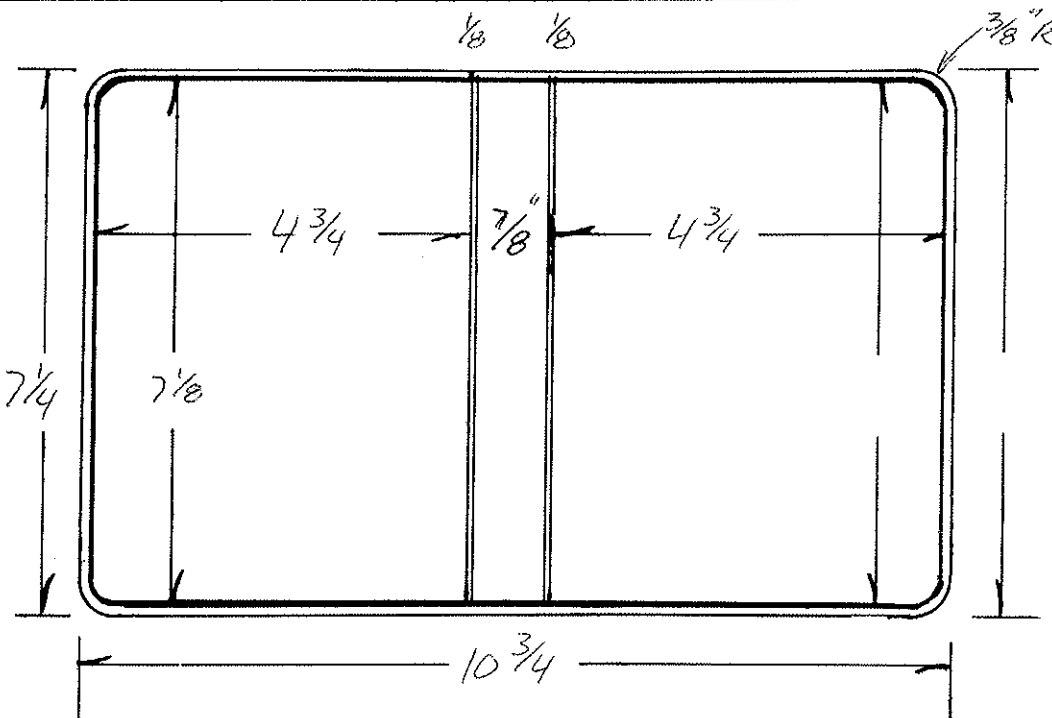

Code	Ga.	Pcs.	Cutting Specs		Code	Ga.	Pcs.	Cutting Specs	
			Size	Out				Size	Out
Cover Mat.		<u>8</u>	<u>X</u>	<u>11 1/2</u>		<u>15</u>	<u>1</u>		
Cover Mat.			<u>X</u>		Lining Mat.			<u>8</u>	<u>X</u>
Vert. Pckt.			<u>X</u>		Lining Mat.			<u>X</u>	
Vert. Pckt.			<u>X</u>		Horz. Pckt.			<u>X</u>	
Pocket			<u>X</u>		Horz. Pckt.			<u>X</u>	
Label Holder			<u>X</u>		Pocket			<u>X</u>	
Material			<u>X</u>		Card Holder			<u>X</u>	
Material			<u>X</u>		Material			<u>X</u>	
Material			<u>X</u>		Material			<u>X</u>	
F.C. Board		<u>7 1/32</u>	<u>X</u>	<u>4 2 1/32</u>	Material			<u>X</u>	
B.C. Board		<u>7 1/32</u>	<u>X</u>	<u>4 2 1/32</u>	B.C. Board			<u>X</u>	
Center Board		<u>7 1/16</u>	<u>X</u>	<u>4 1 1/16</u>	B.B. Board		<u>7 1/32</u>	<u>X</u>	<u>25 1/32</u>
Board		<u>100</u>	<u>2</u>		Board		<u>7 1/16</u>	<u>X</u>	<u>25 1/32</u>
Board			<u>X</u>		Strip			<u>X</u>	
Cover Pad			<u>X</u>		Strip			<u>X</u>	
					B.B. Pad			<u>X</u>	

Product Code

Style Case *VRB (memo)*

Sheet Size $6\frac{3}{4}$ x $4\frac{3}{4}$

Cap. $\frac{1}{2}$ memo Die No. 4686

Order No. 968142

Plate C-12-

Customer

CITY OF WILMINGTON PERSONNEL

Metal
Total Vinyl
Quantity 300
Date 3-18-91
Type Corners
Radius $\frac{3}{8}$
Completed

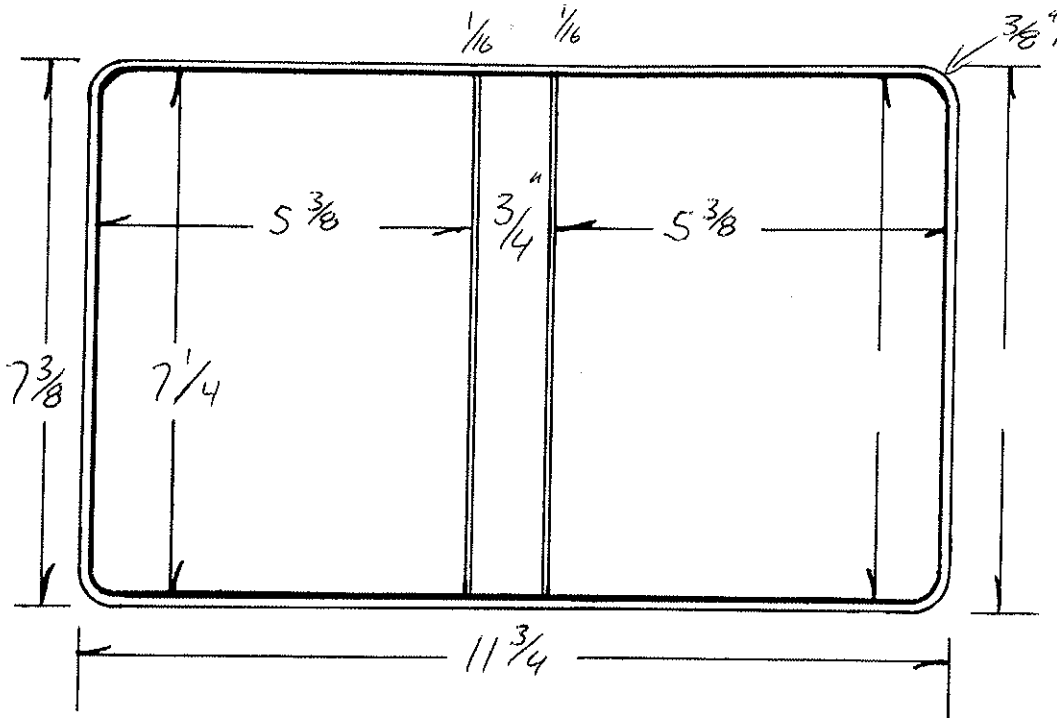

	Gauge	Thick
Tear Seal	#014	$\frac{1}{16}$
Bar Seal	#102	$\frac{1}{16}$
Bar Seal		

	No. of Feet
Tear Seal	
Bar Seal	
Bar Seal	

size - B. Pace

check - YPV

PER SAMPLE

Code	Ga.	PCS	Cutting Specs		Code	Ga.	Pcs.	Cutting Specs	
			Size	Out				Size	Out
Cover Mat.	$8\frac{1}{8}$	15	$12\frac{1}{2}$	1	Lining Mat.	$8\frac{1}{8}$	15	$12\frac{1}{2}$	1
Cover Mat.			X		Lining Mat.			X	
Vert. Pckt.	$8\frac{1}{8}$	15	$3\frac{3}{4}$	1	Horz. Pckt.			X	
Vert. Pckt.			X		Horz. Pckt.			X	
Pocket			X		Pocket			X	
Label Holder			X		Card Holder			X	
Material			X		Material			X	
Material			X		Material			X	
Material			X		Material			X	
F.C. Board	red -		$7\frac{5}{32}$	$5\frac{9}{32}$	B.C. Board			X	
B.G. Board	FLCX		$7\frac{5}{32}$	$5\frac{9}{32}$	B.B. Board	$7\frac{5}{32}$	100	$2\frac{1}{32}$	1
Center Board			X		Board	$7\frac{1}{8}$	48	$5\frac{1}{8}$	1
Board			X		Strip			X	
Cover Pad			X		Strip			X	
					B.B. Pad			X	

Product Code

Style Case *VRB 6 1/2-6-1 DATA*

Sheet Size *6 1/2 x 3 1/2* Cap. *1"*

Die No. *4942*

Order No. *970763*

Plate *D-2-5*

Customer

DAMON CLINICAL LABS

Metal
Total Vinyl
Quantity <i>250</i>
Date <i>12-19-92</i>
Type Corners
Radius
Completed

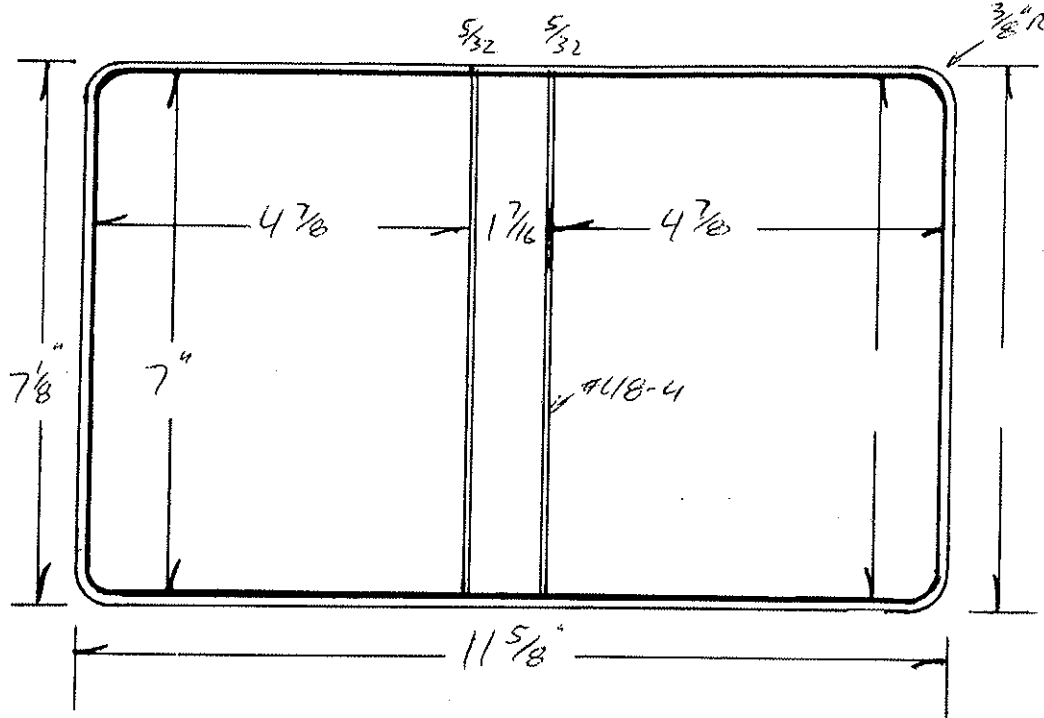

	Gauge	Thick
Tear Seal	<i>.014</i>	<i>1/16</i>
Bar Seal	<i>48-4</i>	<i>5/32</i>
Bar Seal		

	No. of Feet
Tear Seal	
Bar Seal	
Bar Seal	

OLWY - B. PACE
CHECK - KPT

Code	Ga.	Pcs.	Cutting Specs		Code	Ga.	Pcs.	Cutting Specs	
			Size	Out				Size	Out
Cover Mat.	<i>8</i>		<i>12 3/8</i>	<i>14</i>	Lining Mat.	<i>8</i>		<i>12 3/8</i>	<i>14</i>
Cover Mat.			<i>X</i>		Lining Mat.			<i>X</i>	
Vert. Pckt.			<i>X</i>		Horz. Pckt.			<i>X</i>	
Vert. Pckt.			<i>X</i>		Horz. Pckt.	<i>3 3/8</i>		<i>5 3/8</i>	<i>14</i>
Pocket			<i>X</i>		Pocket			<i>X</i>	
Label Holder			<i>X</i>		Card Holder			<i>X</i>	
Material			<i>X</i>		Material			<i>X</i>	
Material			<i>X</i>		Material			<i>X</i>	
Material			<i>X</i>		Material			<i>X</i>	
F.C. Board			<i>6 1/16</i>	<i>100</i>	B.C. Board			<i>X</i>	
B.C. Board			<i>6 1/16</i>	<i>100</i>	B.B. Board	<i>6 1/16</i>		<i>1 1/32</i>	<i>100</i>
Center Board			<i>X</i>		Board			<i>X</i>	
Board			<i>X</i>		Strip			<i>X</i>	
Cover Pad			<i>X</i>		Strip			<i>X</i>	
					B.B. Pad			<i>X</i>	

Product Code

Style Case VRB 6 1/2 - 6 - 3/4 L.L.M.C.

Sheet Size 6 3/4 X 4 1/8

Cap. 3/4" MINO Die No. 4955

Order No. 971004

Plate D-3-

Customer

SOUTHERN COLOR PRINTING

1-27

Metal
Total Vinyl
Quantity 500
Date 1-9-92
Type Corners
Radius 3/8"
Completed

Gauge	Thick
Tear Seal .014	1/16
Bar Seal 48-3	1/8
Bar Seal	

No. of Feet
Tear Seal
Bar Seal
Bar Seal

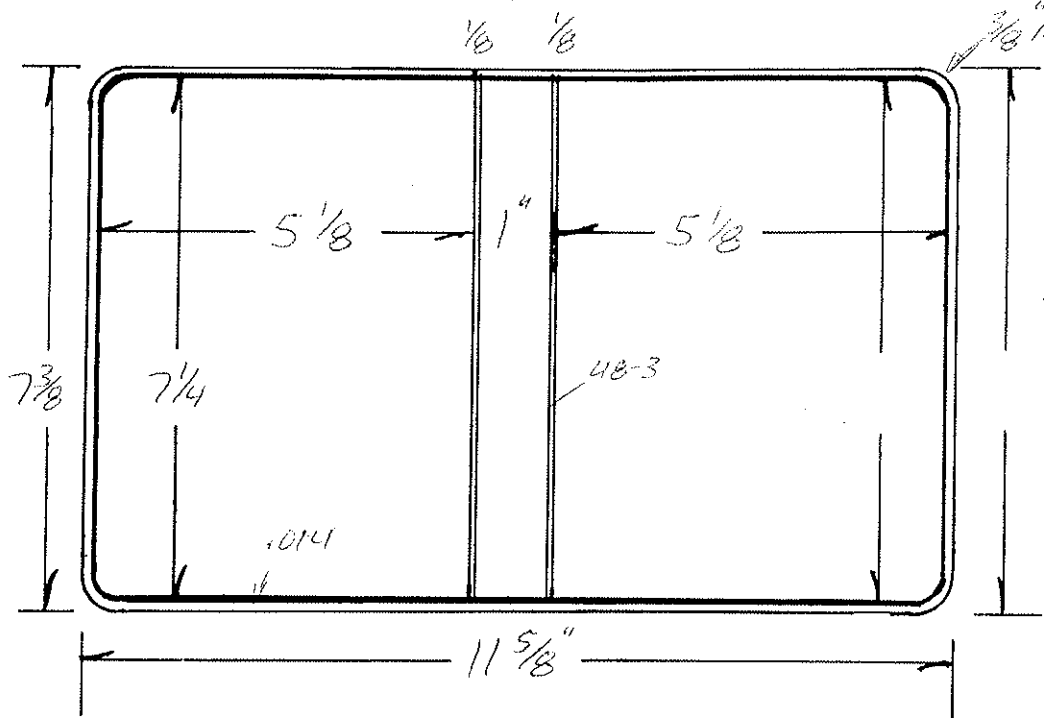

Dwg - B. Price

Check -

Code		Cutting Specs		Code		Cutting Specs		
Ga.	# PCS	Size	Out	Ga.	# Pcs.	Size	Out	
Cover Mat.		8 1/8 X 12 3/8	14	1	Lining Mat.	8 1/8 X 12 3/8	14	1
Cover Mat.		X			Lining Mat.	X		
Vert. Pckt.	14-102	8 1/8 X 2 3/8	14	2	Horz. Pckt.	X		
Vert. Pckt.		X			Horz. Pckt.	X		
Pocket		X			Pocket	X		
Label Holder		X			Card Holder	X		
Material		X			Material	X		
Material		X			Material	X		
Material		X			Material	X		
F.C. Board		7 3/16 X 5 1/16	22	1	B.C. Board	X		
B.C. Board		7 3/16 X 5 1/16	22	1	B.B. Board	7 3/16 X 29/32	100	1
Center Board		X			Board	X		
Board		X			Strip	X		
Cover Pad		X			Strip	X		
					B.B. Pad	X		

DIE #	5157	METAL		RADIUS	1/8
ORDER #	973346	CUSTOMER	MILLER AUDIO	TEAR SEAL	.016
SHEET SIZE	6 3/4 X 5 1/8	STYLE CASE	VINYL RING BINDER	BAR SEAL	253
CAP.	1/2"	DUE DATE		COMPLETED	
LOCATION	D-10-9	QUANTITY		DATE	9-18

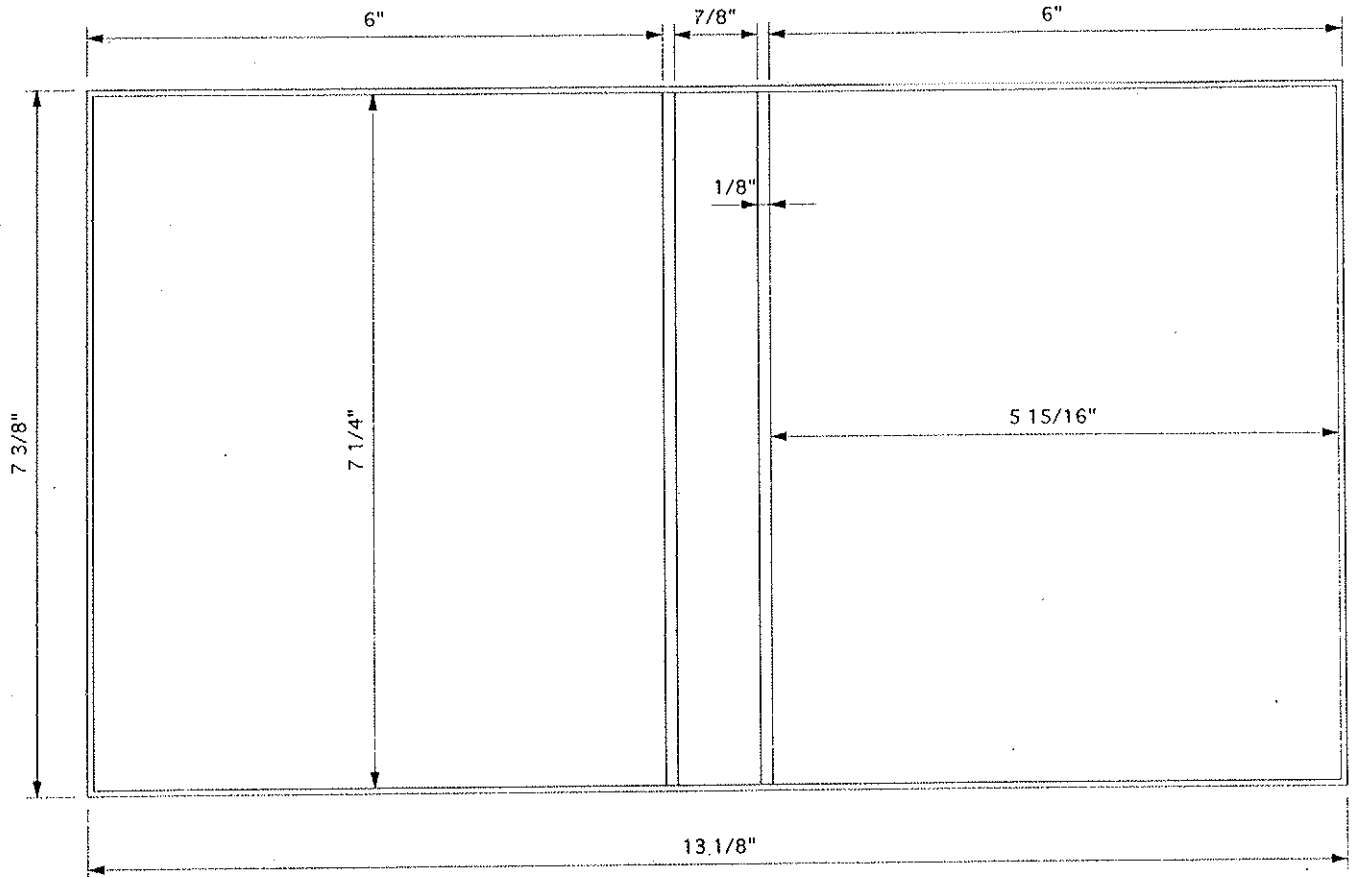

****DO NOT ROUND CORNER BOARDS****

MATERIAL SPECS		GAUGE		MATERIAL SPECS		GAUGE	
COVER MAT.	8 X 13 3/4		1	LINING MAT.	8 X 13 3/4		
COVER MAT.				LINING MAT.			
DIE CUT				HORZ. PKT.			
COL				VERT. PKT.			
LABEL HOLDER				DIE CUT			
GUSSET				REINF.			
BOARD SPECS		GAUGE		BOARD SPECS		GAUGE	
F.C. BOARD	7 3/16 X 5 7/8	100	1	F.C. BOARD	7 5/32 X 5 27/32	120	
B.B. BOARD	7 3/16 X 25/32	100	1	B.B. BOARD	7 5/32 X 25/32	120	
B.C. BOARD	7 3/16 X 5 7/8	100	1	B.C. BOARD	7 5/32 X 5 27/32	120	
FLAP BD.				DIE CUT			
BOARD				DIE CUT			

DIE # 5487		STYLE CASE VINYL RING BINDER		LOCATION	
SHEET SIZE 6 3/4 X 4 5/8 + 1/2		CAP. 3/4		ORDER # 976690	
CUSTOMER MICROPOROUS PRODUCTS INC.				DUE DATE	
QUANTITY	150	RADIUS	3/8	TEAR SEAL	.012
DATE	12-16-93	COMPLETED		BAR SEAL	484

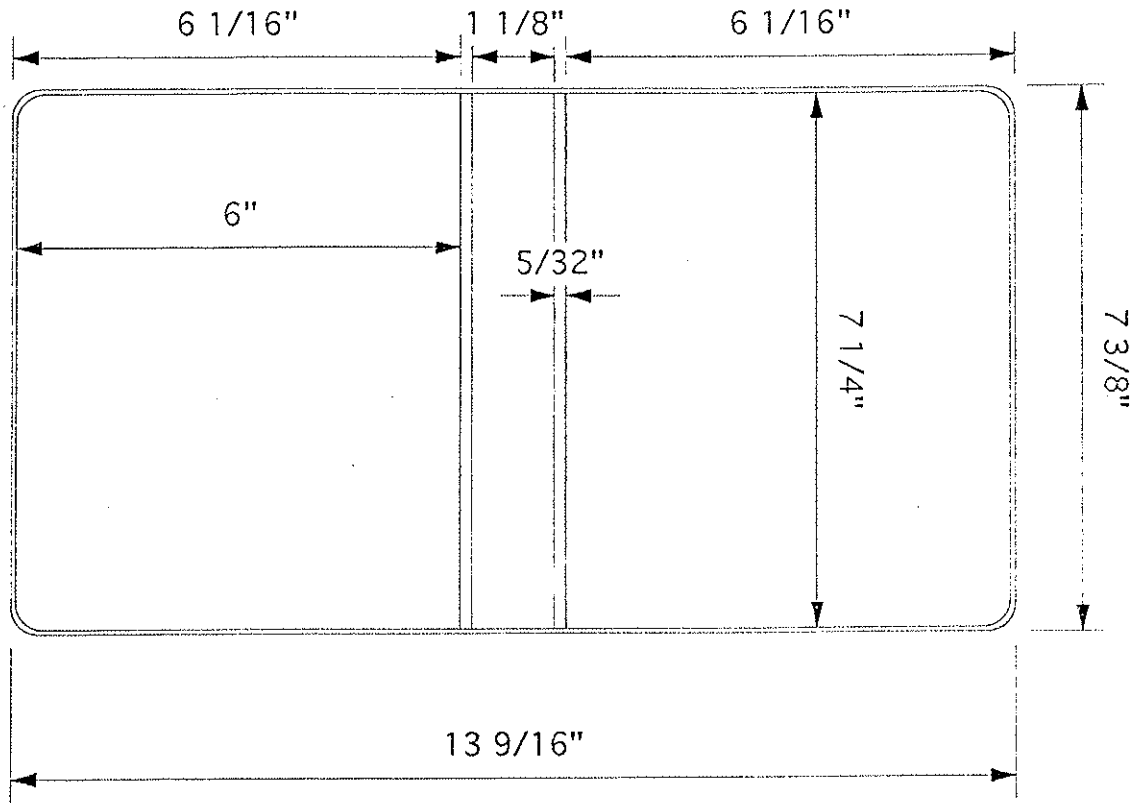

MATERIAL SPECS		GA		PCS	
COVER MATL	8 1/8 X 14 5/16	1	LINING	8 1/8 X 14 5/16	1
COVER MATL			LINING		
VERT PKT			HORZ PKT		
VERT PKT			HORZPKT		
CARD HOLDER			DIAGONAL PKT		
COL			LABEL HOLDER		
EX COL			GUSSETT		
			REINF		

BOARD SPECS					
F.C. BOARD	7 3/16 X 5 15/16	100	1	F.C. BOARD	
B.B. BOARD	7 3/16 X 1 1/32	100	1	B.B. BOARD	
B.C. BOARD	7 3/16 X 5 15/16	100	1	B.C. BOARD	
BU STRIP					

DIE # 5505		STYLE CASE VINYL RING BINDER		LOCATION	
SHEET SIZE 6 3/4 X 3 3/4 + 1/2		CAP. 3/4		ORDER # 977210	
CUSTOMER LOCKHEED DPC				DUE DATE	
QUANTITY	250	RADIUS		TEAR SEAL	.012
DATE		COMPLETED		BAR SEAL	102

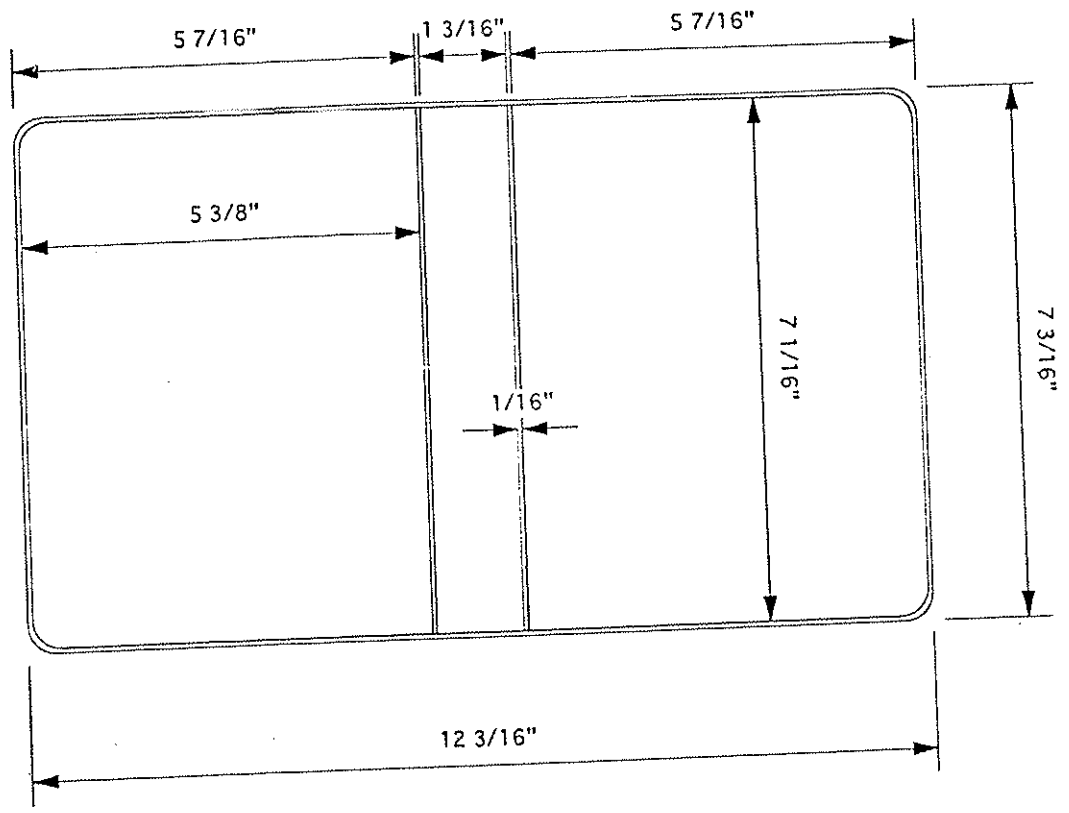

MATERIAL SPECS		GA	PCS	GA		PCS
COVER MATL	7 15/16 X 13	1	LINING	7 15/16 X 13		1
COVER MATL			LINING			
VERT PKT			HORZ PKT			
VERT PKT			HORZPKT			
CARD HOLDER			DIAGONAL PKT			
COL			LABEL HOLDER			
EX COL			GUSSET			
			REINF			

BOARD SPECS					
F.C. BOARD	7 X 5 5/16	1	F.C. BOARD		
B.B. BOARD	7 X 1 3/32	1	B.B. BOARD		
B.C. BOARD	7 X 5 5/16	1	B.C. BOARD		
BU STRIP					

DIE #	5669	STYLE CASE	VINYL MEMO BINDER	LOCATION	E -14-9
CUSTOMER	COLAD			ORDER #	979344
SHEET SIZE	6 3/4 X 4 3/4	CAP	1/2	DUE DATE	10-31-94
QUANTITY	550	RADIUS		TEAR SEAL	.014
DATE	9-21-94	COMPLETED		BAR SEAL	102

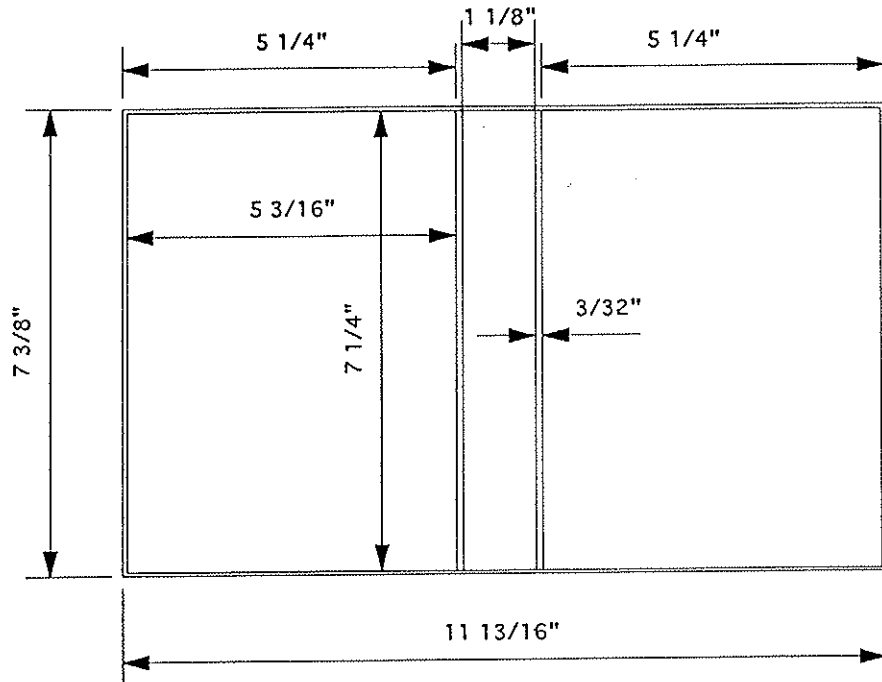

MATERIAL SPECS		GA	PCS			GA	PCS
COVER MAT.	8 1/8 X 12 9/16		1	LINING	8 1/8 X 12 9/16		1
COVER MAT.				LINING			
VERT PKT.				HORZ PKT.	3 3/8 X 12 9/16		1
CARD HOLDER				DIAGONAL PKT.			
COL				LABEL HOLDER			
				DIE CUT POCKET			

BOARD SPECS		GA	PCS			GA	PCS
F.C. BOARD	7 3/16 X 5 1/8	100	1	F.C. BOARD			
B.B. BOARD	7 3/16 X 1 1/16	100	1	B.C. BOARD			
B.C. BOARD	7 3/16 X 5 1/8	100	1	B.C. BOARD			
B. UP STRIP							

DIE #	5711	CAP.	1	METAL	MEMO W/BOOSTER
STYLE CASE	VINYL RING BINDER				LOCATION
SHEET SIZE	OA SIZE	6 1/2 X 5 1/8		ORDER #	979857
CUSTOMER	AGNEW GEISLER			DUE DATE	11-30-94
QUANTITY	500	RADIUS	3/8	TEAR SEAL	.014
DATE	11-15-94	COMPLETED		BAR SEAL	102

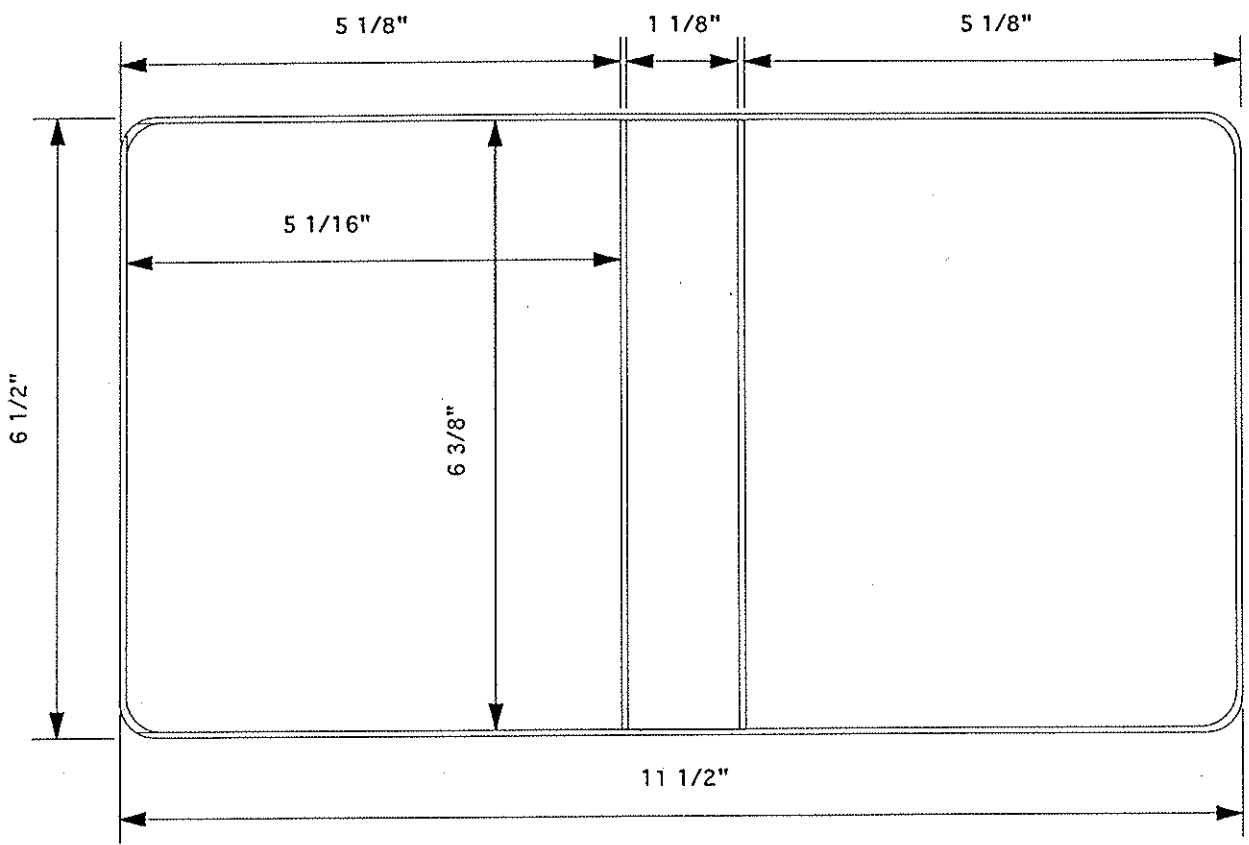

MATERIAL SPECS		GA	PCS			GA	PCS
COVER MAT.	8 X 13		1	LINING MAT	8 X 13		1
COVER MAT.				LINING MAT			
VERT PKT				HORZ PKT	2 7/8 X 5 5/8		1
CARD HOLDER				GUSSET			
COL				DIAGONAL PKT			
LABEL HOLDER				REINF			

BOARD SPECS		GA	PCS			GA	PCS
F.C. BOARD	6 5/16 X 5	80PT.	1	F.C. BOARD			
B.B. BOARD	6 5/16 X 1 1/16	80PT.	1	B.B. BOARD			
B.C. BOARD	6 5/16 X 5	80PT.	1	B.C. BOARD			
B.U. STRIP							

DIE #	5902	METAL	2 BOOSTER 6 RING	RADIUS	3/8
ORDER #	982458	CUSTOMER	R L BRYAN CO	TEAR SEAL	.012
SHEET SIZE	OA - 6 1/2 X 4 5/8	STYLE CASE	VINYL RING BINDER	BAR SEAL	253
CAP.	1/2	DUE DATE	9-19-95	COMPLETED	
LOCATION	F-12-1	QUANTITY	2000	DATE	9-7-95

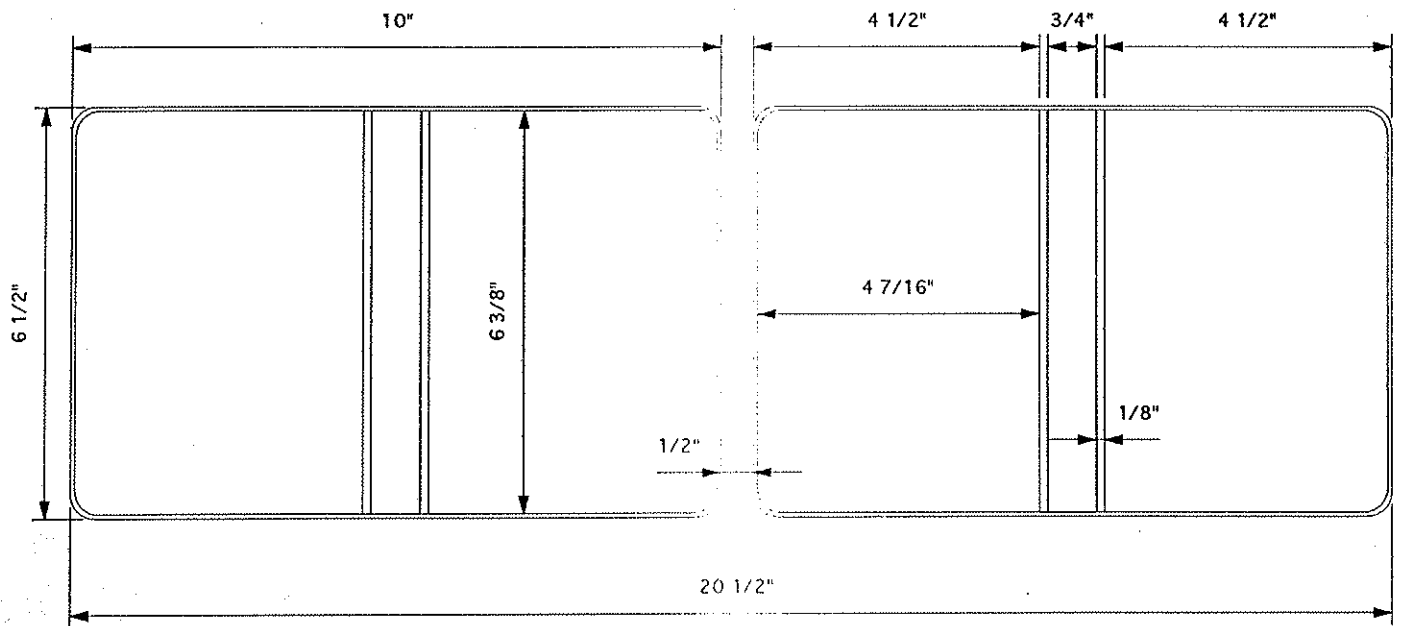

MATERIAL SPECS		GAUGE		PCS.		MATERIAL SPECS		GAUGE		PCS.	
COVER MAT.	7 1/4 X 21 1/4	2	OUT	1	LINING MAT.	7 1/4 X 21 1/4	2	OUT	1		
COVER MAT.					LINING MAT.						
DIE CUT					HORZ. PKT.						
COL					VERT. PKT.						
LABEL HOLDER					DIE CUT						
GUSSET					REINF.						

BOARD SPECS		GAUGE		PCS.		BOARD SPECS		GAUGE		PCS.	
F.C. BOARD	6 5/16 X 4 3/8	48	2	2	F.C. BOARD						
B.B. BOARD	6 5/16 X 21/32	100	2	2	B.B. BOARD						
B.C. BOARD	6 5/16 X 4 3/8	48	2	2	B.C. BOARD						
B.U. STRIP					DIE CUT						
DIE CUT					DIE CUT						

DIE #	5909	METAL	MEMO W/BOOSTER	RADIUS	3/8"
ORDER #	982558	CUSTOMER	BRYAN FOODS PRINT SHOP	TEAR SEAL	.014
SHEET SIZE	6 X 3 1/2	STYLE CASE	VINYL MEMO BINDER	BAR SEAL	253
CAP.	1/2"	DUE DATE	10-3-95	COMPLETED	
LOCATION	F-13-3	QUANTITY	200	DATE	9-14-95

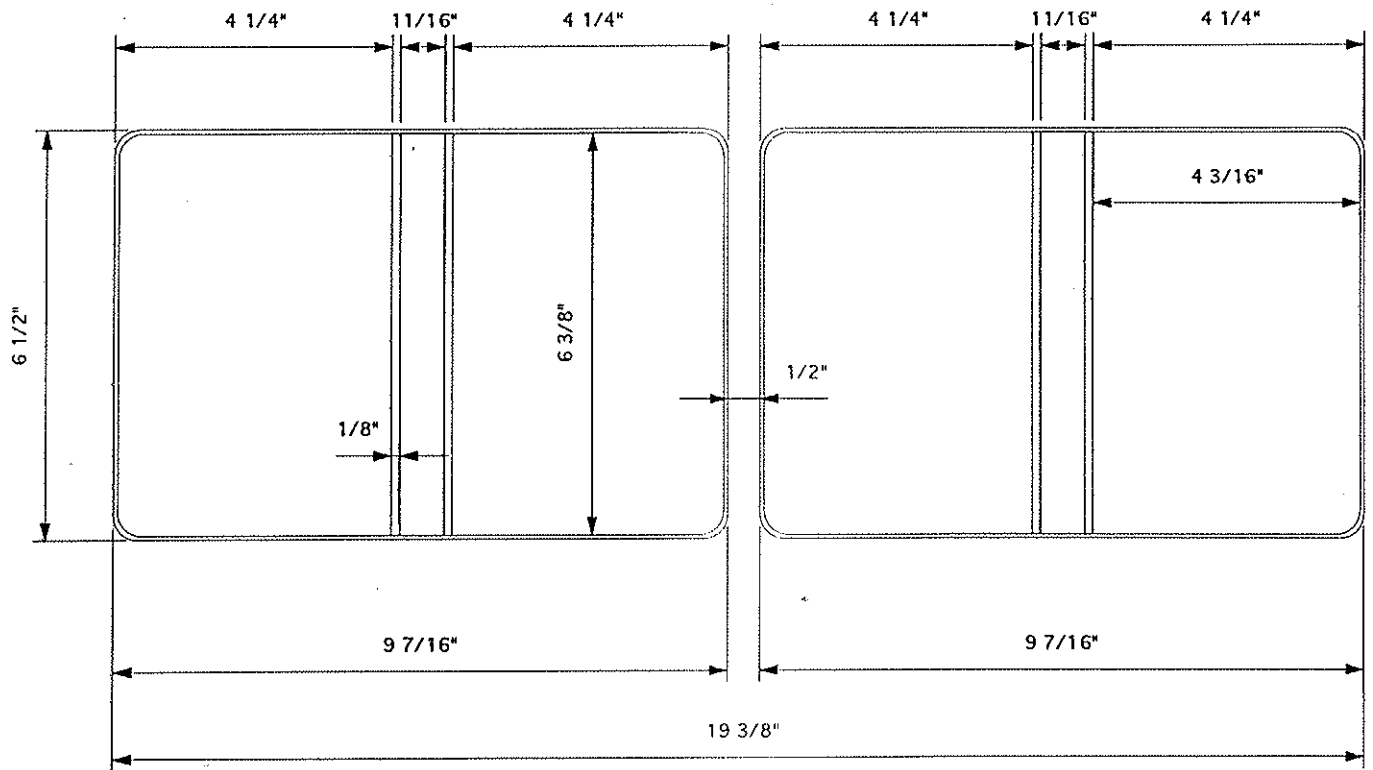

2-up

MATERIAL SPECS		GAUGE		PCS.		MATERIAL SPECS		GAUGE	
COVER MAT.	7 1/4 X 20 1/8	2	OUT	1	LINING MAT.	7 1/4 X 20 1/8	2	OUT	
COVER MAT.					LINING MAT.				
DIE CUT					HORZ. PKT.				
COL					VERT. PKT.	7 1/4 X 2 3/8			
LABEL HOLDER					DIE CUT				
GUSSET					REINF.				
BOARD SPECS		GAUGE		PCS.		BOARD SPECS		GAUGE	
F.C. BOARD	6 5/16 X 4 1/8	48		1	F.C. BOARD				
B.B. BOARD	6 5/16 X 19/32	48		1	B.B. BOARD				
B.C. BOARD	6 5/16 X 4 1/8	48		1	B.C. BOARD				
B.U. STRIP					DIE CUT				
DIE CUT					DIE CUT				

DIE #	6229	METAL	1/2" RR	RADIUS	3/8"
ORDER #	986949	CUSTOMER	CARTON SALES	TEAR SEAL	.014
SHEET SIZE	7 3/4 X 6 1/8	STYLE CASE	WYL. BINDER	BAR SEAL	253
CAP.	1/2"	DUE DATE	1	COMPLETED	
LOCATION	H-5-3	QUANTITY		DATE	4-7-97

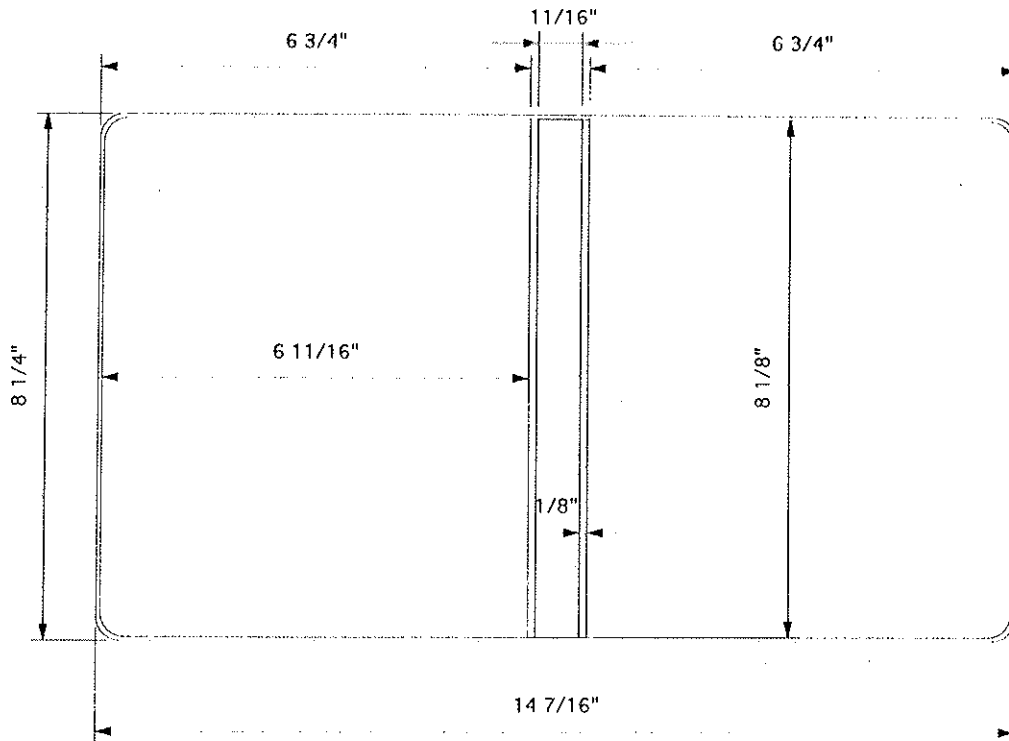

MATERIAL SPECS		GAUGE		PCS.		MATERIAL SPECS		GAUGE	
COVER MAT.	9 X 15 1/4		1	LINING MAT.	9 X 15 1/4				
COVER MAT.				LINING MAT.					
DIE CUT				HORZ. PKT.					
COL	8 1/2 X 15 1/4		1	VERT. PKT.					
LABEL HOLDER				DIE CUT					
GUSSET				REINF.					
BOARD SPECS		GAUGE		PCS.		BOARD SPECS		GAUGE	
F.C. BOARD	8 1/16 X 6 5/8	100	1	F.C. BOARD					
B.B. BOARD	8 1/16 X 19/32	100	1	B.B. BOARD					
B.C. BOARD	8 1/16 X 6 5/8	100	1	B.C. BOARD					
FLAP BD.				DIE CUT					
BOARD				DIE CUT					

DIE #	6328	METAL	MEMO	RADIUS	1/4"
ORDER #	76538	CUSTOMER	GRAND LODGE	TEAR SEAL	.012
SHEET SIZE	6 X 4 1/2	STYLE CASE	VINYL RING BINDER	BAR SEAL	253
CAP.	1"	DUE DATE	10-6-97	COMPLETED	
LOCATION	1-3-8	QUANTITY	2000	DATE	9-18-97

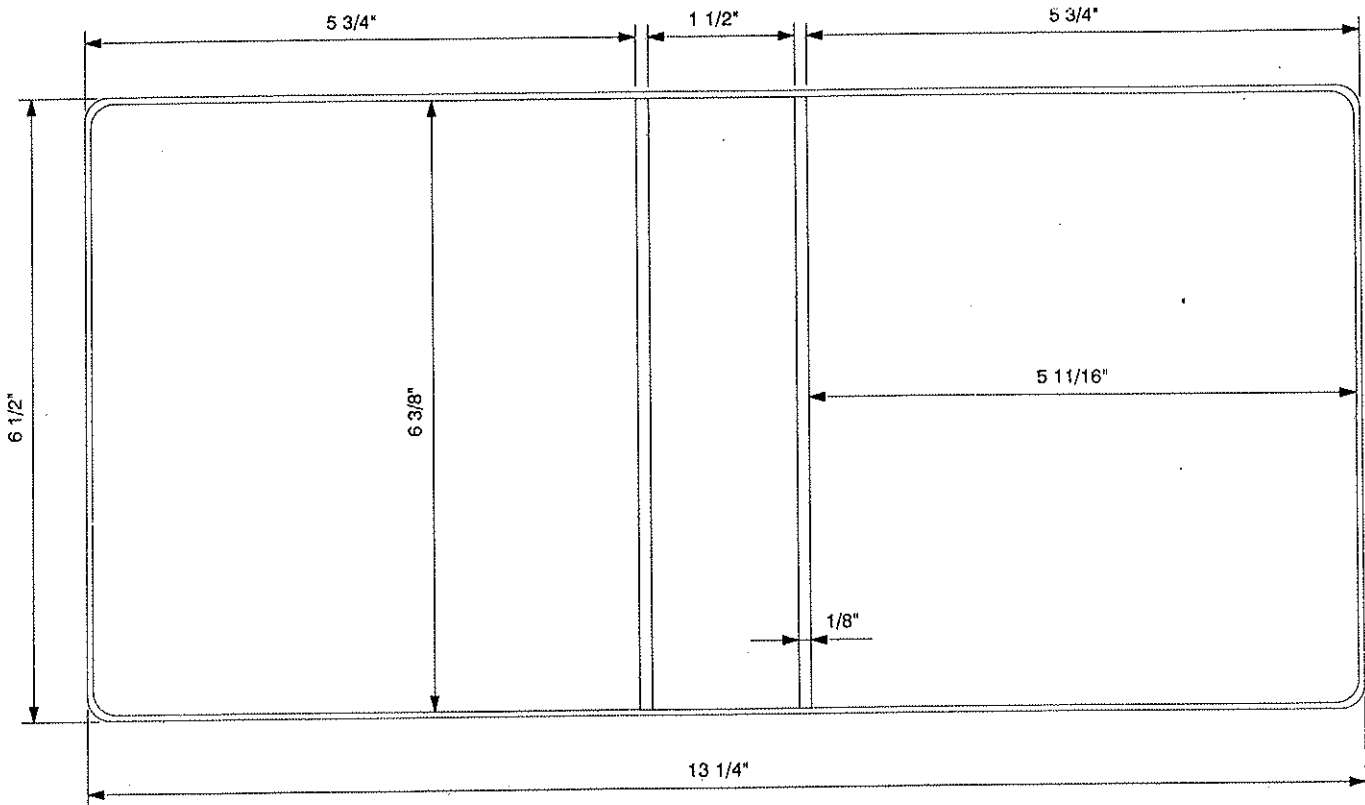

MATERIAL SPECS		GAUGE		MATERIAL SPECS		GAUGE	
COVER MAT.	7 1/4 X 14		1	LINING MAT.	7 1/4 X 14		
COVER MAT.				LINING MAT.			
DIE CUT				HORZ. PKT.			
COL				VERT. PKT.			
LABEL HOLDER				DIE CUT			
GUSSET				REINF.			

BOARD SPECS		GAUGE		BOARD SPECS		GAUGE	
F.C. BOARD	6 5/16 X 5 5/8	100	1	F.C. BOARD			
B.B. BOARD	6 5/16 X 1 13/32	100	1	B.B. BOARD			
B.C. BOARD	6 5/16 X 5 5/8	100	1	B.C. BOARD			
FLAP BD.				DIE CUT			
BOARD				DIE CUT			

DIE #	6578	METAL	LOC	RADIUS	3/8"
ORDER #	169885	CUSTOMER	IND. APPAREL GROUP	TEAR SEAL	.012
SHEET SIZE	6 X 8	STYLE CASE	VINYL BINDER	BAR SEAL	48-4
CAP.	1"	DUE DATE	10-8-98	COMPLETED	
LOCATION	A-18-3	QUANTITY	50	DATE	10-2-98

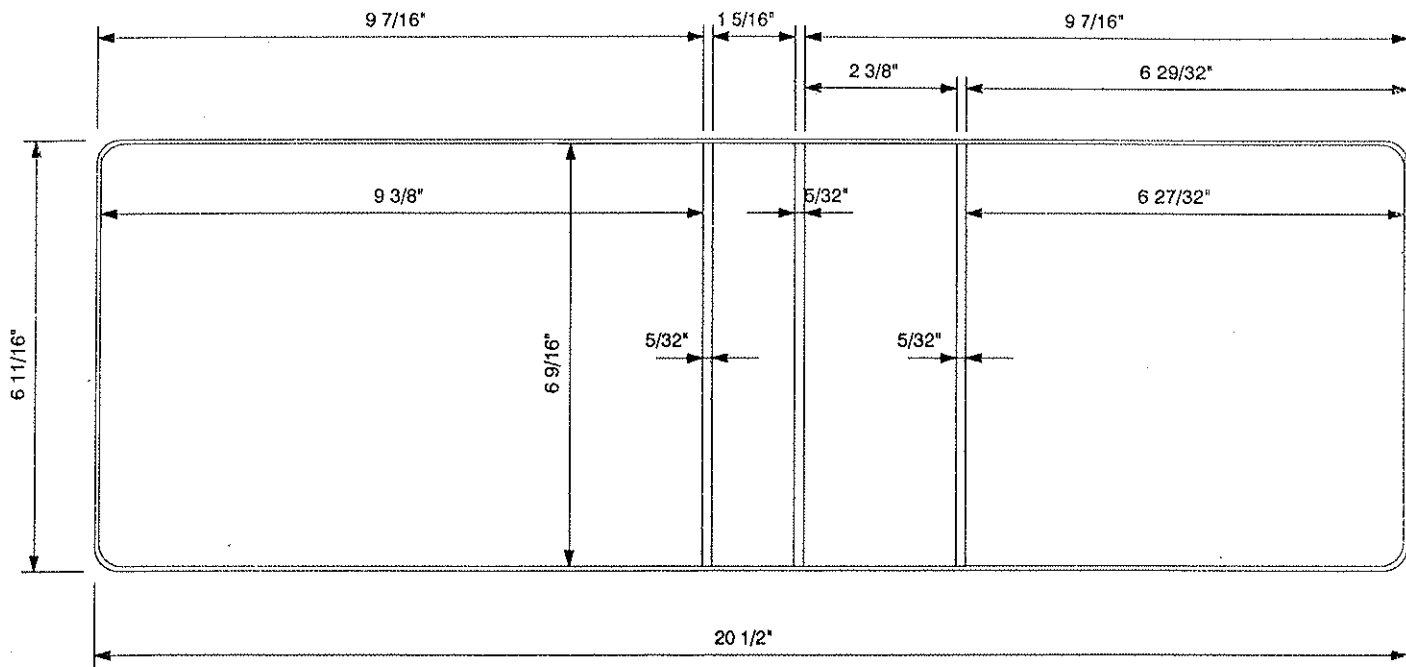

MATERIAL SPECS		GAUGE	PCS.	MATERIAL SPECS		GAUGE	PCS.
COVER MAT.	7 3/4 X 21 1/2		1	LINING MAT.	7 1/2 X 21 1/4		1
COVER MAT.				LINING MAT.			
DIE CUT				HORZ. PKT.			
COL				VERT. PKT.			
LABEL HOLDER				DIE CUT			
GUSSET				REINF.			
BOARD SPECS		5/16" R. CORNERS		BOARD SPECS		5/16" R. CORNERS	
F.C. BOARD	6 15/32 X 6 3/4	100	1	F.C. BOARD			
B.B. BOARD	6 15/32 X 1 7/32	100	1	B.B. BOARD			
B.C. BOARD	6 15/32 X 9 9/32	100	1	B.C. BOARD			
FLAP BD.				DIE CUT			
BOARD	6 1/2 X 2 9/32	100	1	DIE CUT			

DIE #	6822	METAL	RR W/B	RADIUS	5/16"
ORDER #	294483	CUSTOMER	GBS PRINTED TRODUCTS	TEAR SEAL	.012
SHEET SIZE	6.75 X 3.75	STYLE CASE	VINYL RING BINDER	BAR SEAL	253
CAP.	3/4"	DUE DATE	1-7-00	COMPLETED	
LOCATION		QUANTITY	1000	DATE	12-16-99

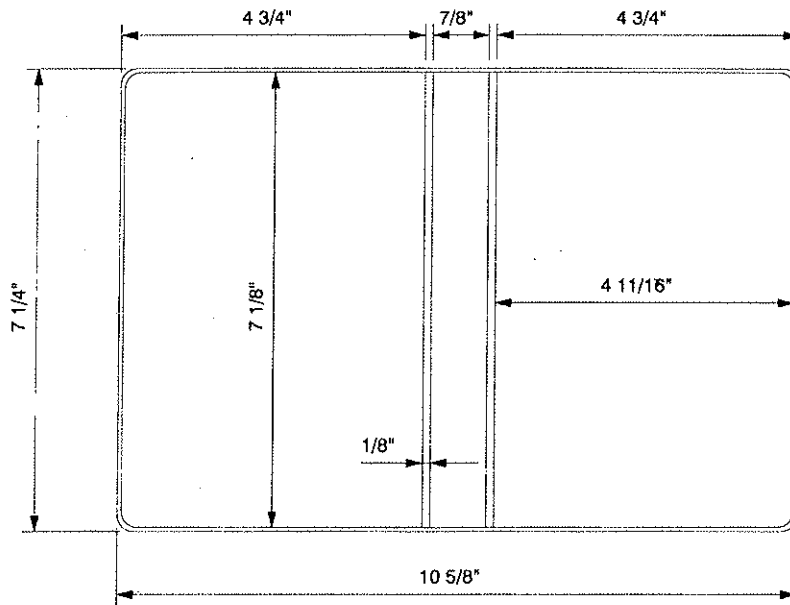

MATERIAL SPECS		GAUGE	PCS.	MATERIAL SPECS		GAUGE	PCS.
COVER MAT.	8 X 11 3/8		1	LINING MAT.	8 X 11 3/8		1
COVER MAT.				LINING MAT.			
DIE CUT				HORZ. PKT.			
COL				VERT. PKT.	8 X 2 3/8		1
LABEL HOLDER				DIE CUT			
GUSSET				REINF.			
BOARD SPECS		GAUGE	PCS.	BOARD SPECS		GAUGE	PCS.
F.C. BOARD	7 1/16 X 4 5/8	100	1	F.C. BOARD	5/16" R. CORNERS		
B.B. BOARD	7 1/16 X 25/32	100	1	B.B. BOARD			
B.C. BOARD	7 1/16 X 4 5/8	100	1	B.C. BOARD			
FLAP BD.				DIE CUT			
BOARD				DIE CUT			

DIE #	6863	METAL	MEMO W/1 BOOSTER	RADIUS	3/8"
ORDER #	311677	CUSTOMER	4 D PRINTING	TEAR SEAL	.012
SHEET SIZE	6 X 8 3/4	STYLE CASE	VINYL MEMO BINDER	BAR SEAL	253
CAP.	1/2"	DUE DATE	2-23-00	COMPLETED	
LOCATION		QUANTITY	2000.	DATE	2-14-00

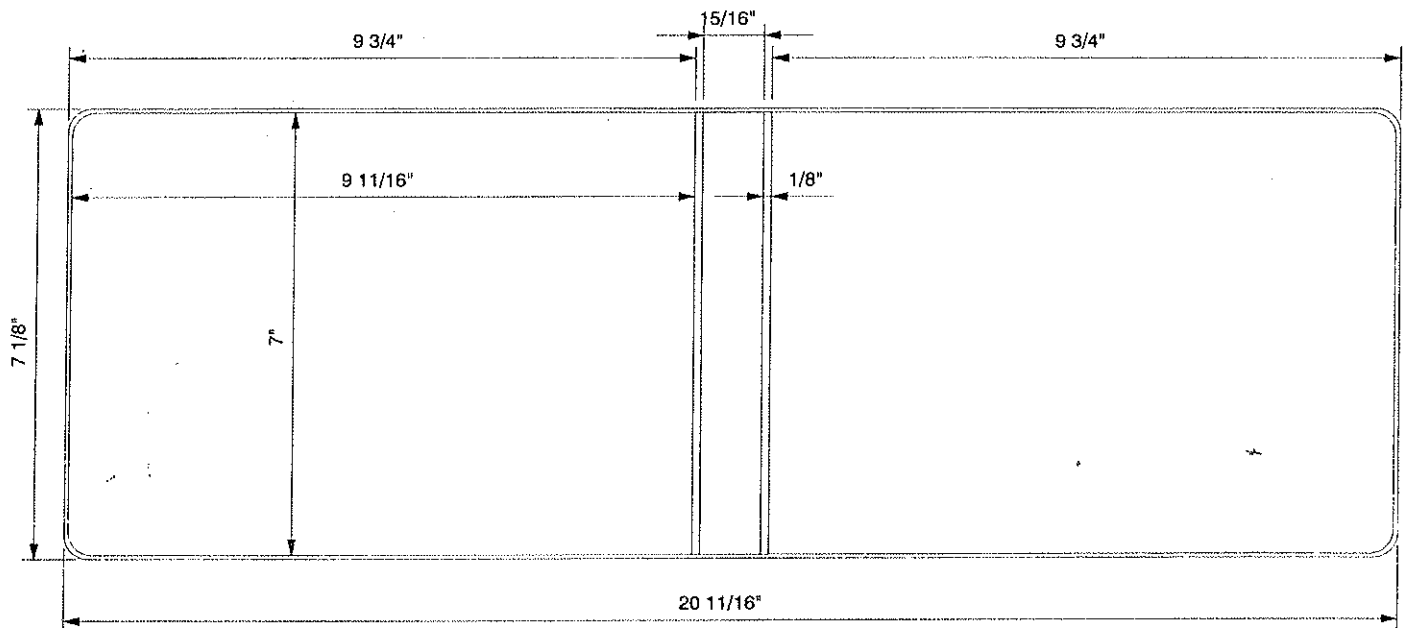

MATERIAL SPECS		GAUGE	PCS.	MATERIAL SPECS	GAUGE	PCS.
COVER MAT.	7 7/8 X 21 1/2		1	LINING MAT.	7 7/8 X 21 1/2	1
COVER MAT.				LINING MAT.		
DIE CUT				HORZ. PKT.	3 3/8 x 10 1/4	
COL				VERT. PKT.		
LABEL HOLDER				DIE CUT		
GUSSET				REINF.		

BOARD SPECS		GAUGE	PCS.	BOARD SPECS	GAUGE	PCS.
F.C. BOARD	6 15/16 X 9 5/8	100	1	F.C. BOARD		
B.B. BOARD	6 15/16 X 27/32	100	1	B.B. BOARD		
B.C. BOARD	6 15/16 X 9 5/8	100	1	B.C. BOARD		
FLAP BD.				DIE CUT		
BOARD -				DIE CUT		

DIE #	6993	METAL	6 RING MEMO W/B	RADIUS	3/8
ORDER #	376841	CUSTOMER	MILLENIUUM MARKETING	TEAR SEAL	.010
SHEET SIZE	6.375 x 8.875	STYLE CASE	VINYL PHOTO BINDER	BAR SEAL	48-3
CAP.	1"	DUE DATE	10-17-00	COMPLETED	
LOCATION		QUANTITY	2500	DATE	10-5-00

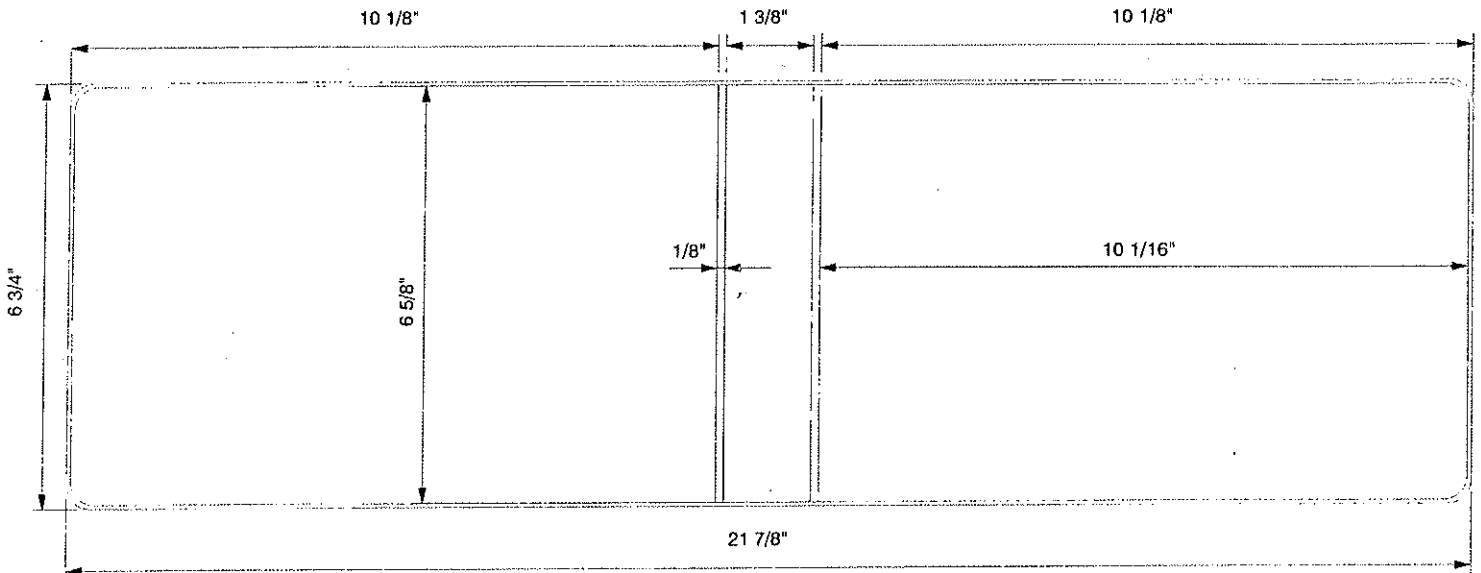

MATERIAL SPECS		GAUGE	PCS.	MATERIAL SPECS		GAUGE	PCS.
COVER MAT.	7 1/2 X 22 3/8		1	LINING MAT.	7 1/2 X 22 3/8		1
COVER MAT.				LINING MAT.			
DIE CUT				HORZ. PKT.			
COL				VERT. PKT.			
LABEL HOLDER				DIE CUT			
GUSSET				REINF.			

BOARD SPECS		GAUGE	PCS.	BOARD SPECS		GAUGE	PCS.
	5/16" R. CORNERS				5/16" R. CORNERS		
F.C. BOARD	6 9/16 X 10	100	1	F.C. BOARD			
B.B. BOARD	6 9/16 X 1 9/32	100	1	B.B. BOARD			
B.C. BOARD	6 9/16 X 10	100	1	B.C. BOARD			
FLAP BD.				DIE CUT			
BOARD				DIE CUT			

DIE #	7816	METAL	2 RING NB RR	RADIUS	3/8"
ORDER #	657723	CUSTOMER	ON TIME PRINTING	TEAR SEAL	.0148-4
SHEET SIZE	6 X 10	STYLE CASE	VINYL BINDER	BAR SEAL	
CAP.	1"	DUE DATE	1-17-05	COMPLETED	1-14-05
LOCATION		QUANTITY	50	DATE	

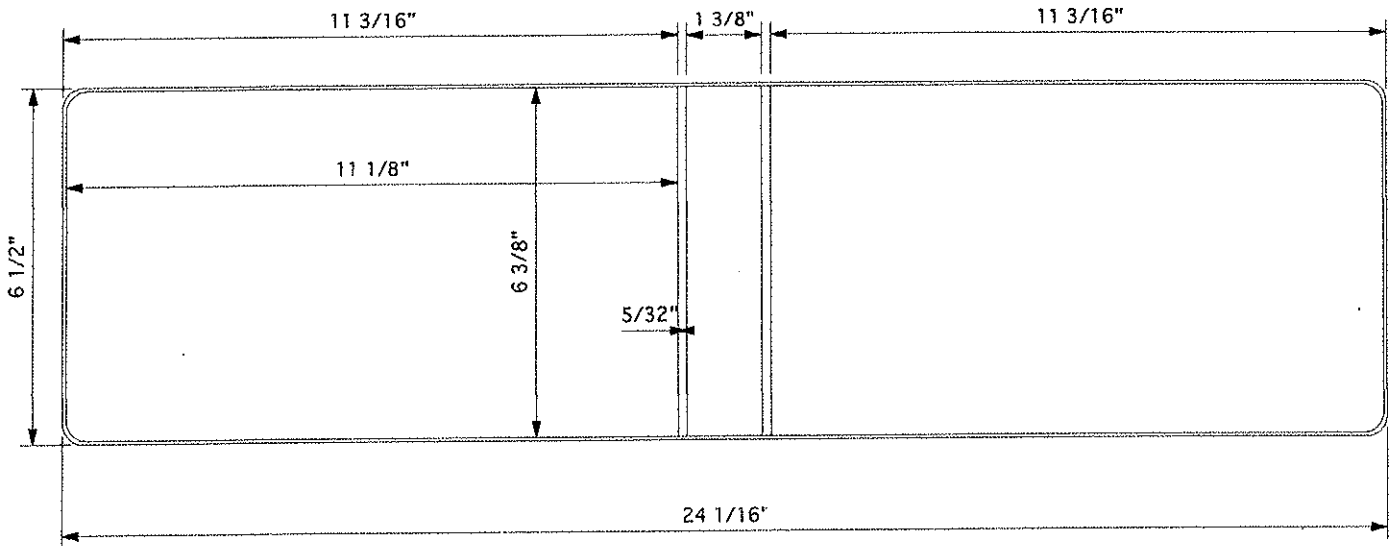

MATERIAL SPECS		GAUGE	PCS.	MATERIAL SPECS		GAUGE	PCS.
COVER MAT.	7 1/4 X 24 13/16		1	LINING MAT.	7 1/4 X 24 13/16		1
COVER MAT.				LINING MAT.			
DIE CUT				HORZ. PKT.			
COL				VERT. PKT.			
LABEL HOLDER				DIE CUT			
GUSSET				REINF.			
BOARD SPECS		GAUGE	PCS.	BOARD SPECS		GAUGE	PCS.
5/16" R. CORNERS				5/16" R. CORNERS			
F.C. BOARD	6 5/16 X 11 1/16	100	1	F.C. BOARD			
B.B. BOARD	6 5/16 X 1 9/32	100	1	B.B. BOARD			
B.C. BOARD	6 5/16 X 11 1/16	100	1	B.C. BOARD			
FLAP BD.				DIE CUT			
BOARD				DIE CUT			

DIE #	8036	METAL	MEMO METAL	RADIUS	1/8"
ORDER #	709351	CUSTOMER	MOUNTIAN BROOK CLUB	TEAR SEAL	.014
SHEET SIZE	6 3/4 X 4 3/4	STYLE CASE	VINYL MEMO BINDER	BAR SEAL	253
CAP.	3/4"	DUE DATE	12-15-05	COMPLETED	
LOCATION		QUANTITY	1000	DATE	12-8-05

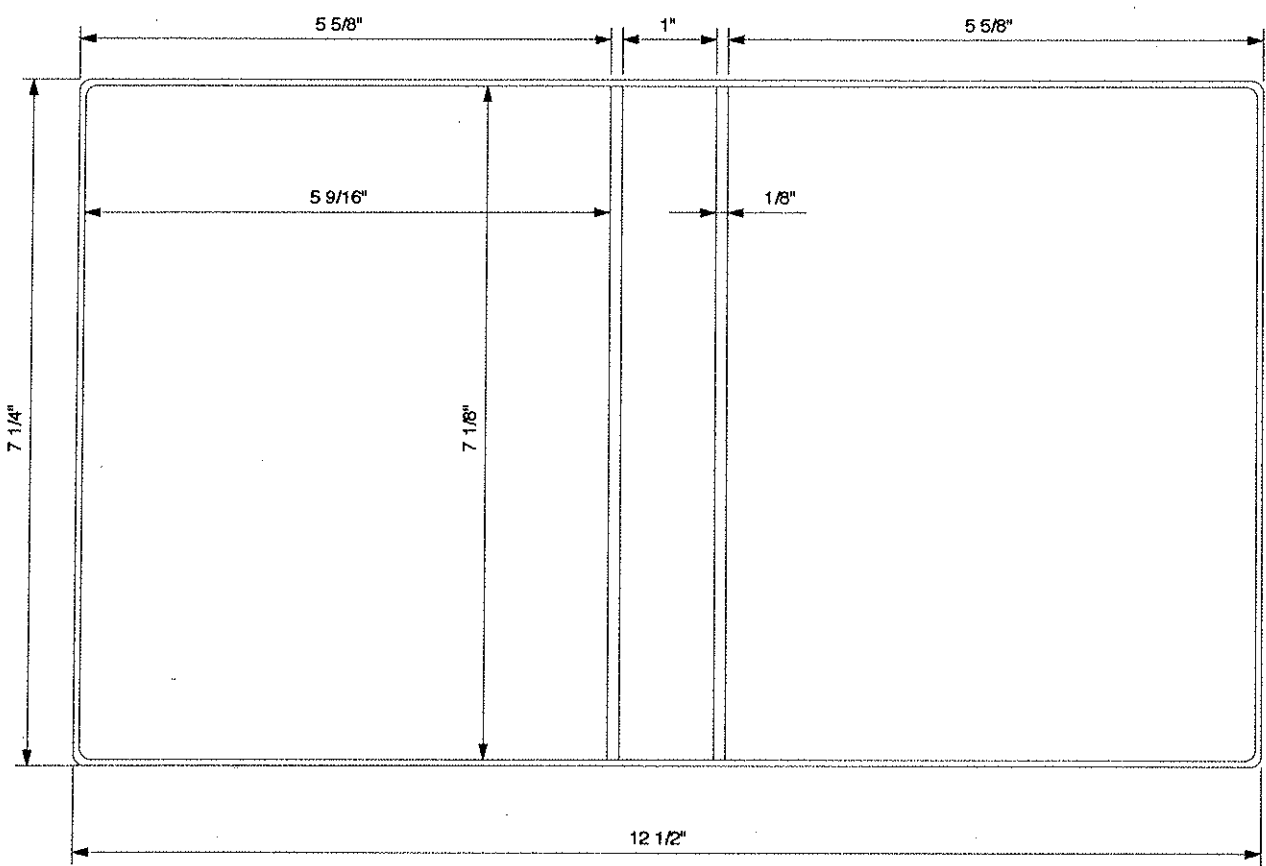

MATERIAL SPECS		GAUGE	PCS.	MATERIAL SPECS		GAUGE	PCS.
COVER MAT.	8 X 13 1/4		1	LINING MAT.	8 X 13 1/4		1
COVER MAT.				LINING MAT.			
DIE CUT				HORZ. PKT.			
COL				VERT. PKT.			
LABEL HOLDER				DIE CUT			
GUSSET				REINF.			
BOARD SPECS		GAUGE	PCS.	BOARD SPECS		GAUGE	PCS.
F.C. BOARD	7 1/16 X 5 1/2	100	1	F.C. BOARD	5/16" R. CORNERS		
B.B. BOARD	7 1/16 X 29/32	100	1	B.B. BOARD			
B.C. BOARD	7 1/16 X 5 1/2	100	1	B.C. BOARD			
FLAP BD.				DIE CUT			
BOARD				DIE CUT			

DIE #	8325	METAL	6 RING MEMO	RADIUS	1/4"
ORDER #	787000	CUSTOMER	R & J BARDON PRINTING	TEAR SEAL	.012
SHEET SIZE	7 X 4 1/4	STYLE CASE	VINYL BINDER	BAR SEAL	.079
CAP.	1/2"	DUE DATE	5-16-07	COMPLETED	
LOCATION		QUANTITY	400	DATE	5-3-07

*** WARNING DRAWING NOT ACTUAL SIZE ***

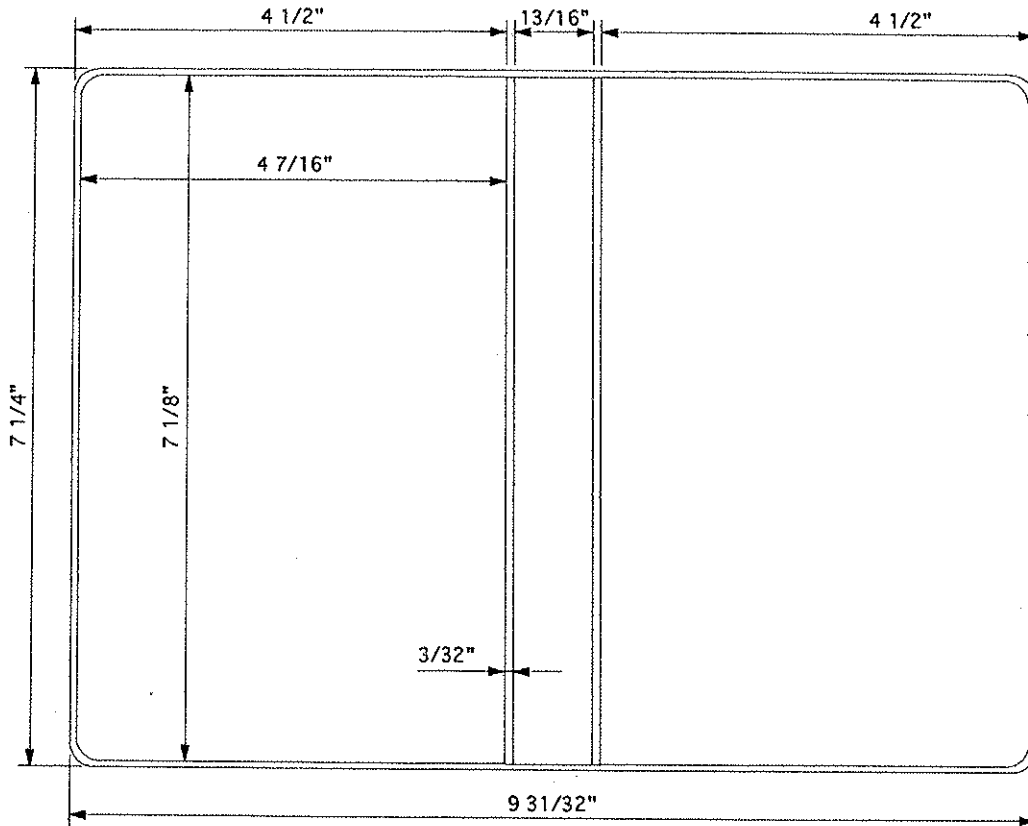

MATERIAL SPECS		GAUGE	PCS.	MATERIAL SPECS		GAUGE	PCS.
COVER MAT.	8 X 10 3/4		1	LINING MAT.	8 X 10 3/4		1
COVER MAT.				LINING MAT.			
DIE CUT				HORZ. PKT.			
COL				VERT. PKT.			
LABEL HOLDER				DIE CUT			
GUSSET				REINF.			
BOARD SPECS		GAUGE	PCS.	BOARD SPECS		GAUGE	PCS.
F.C. BOARD	7 1/16 X 4 3/8	48	1	F.C. BOARD	5/16" R. CORNERS		
B.B. BOARD	7 1/16 X 23/32	48	1	B.B. BOARD			
B.C. BOARD	7 1/16 X 4 3/8	48	1	B.C. BOARD			
FLAP BD.				DIE CUT			
BOARD				DIE CUT			

DIE #	8332	METAL	MEMO	RADIUS	1/4"
ORDER #	789275	CUSTOMER	COMMUNIQUE	TEAR SEAL	.012
SHEET SIZE	6 3/4 X 4 1/4	STYLE CASE	VINYL BINDER	BAR SEAL	.079
CAP.	1/2"	DUE DATE	5-31-07	COMPLETED	
LOCATION		QUANTITY	1000	DATE	5-25-07

*** WARNING DRAWING NOT ACTUAL SIZE ***

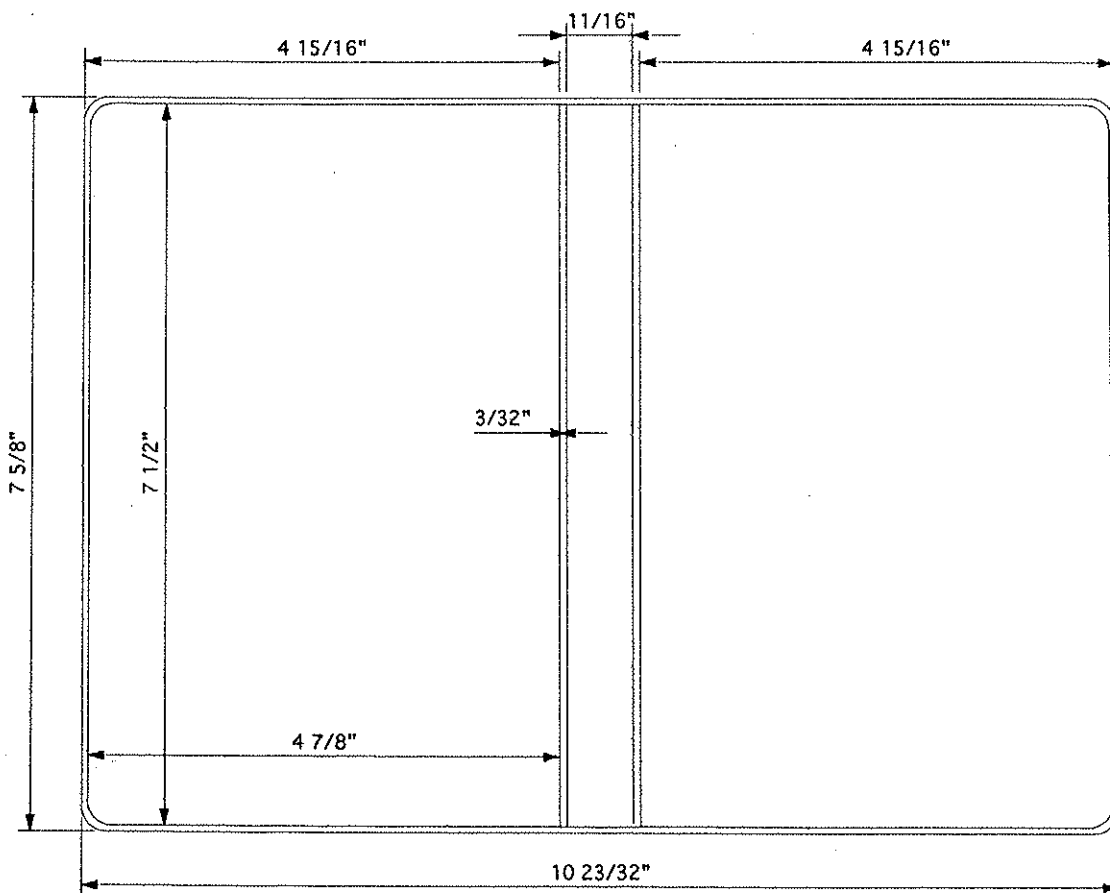

MATERIAL SPECS		GAUGE	PCS.	MATERIAL SPECS		GAUGE	PCS.
COVER MAT.	8 3/8 X 11 1/2		1	LINING MAT.	8 3/8 X 11 1/2		1
COVER MAT.				LINING MAT.			
DIE CUT				HORZ. PKT.			
COL				VERT. PKT.			
LABEL HOLDER				DIE CUT			
GUSSET				REINF.			
BOARD SPECS		GAUGE	PCS.	BOARD SPECS		GAUGE	PCS.
F.C. BOARD	7 7/16 X 4 13/16	100	1	F.C. BOARD	5/16" R. CORNERS		
B.B. BOARD	7 7/16 X 19/32	100	1	B.B. BOARD			
B.C. BOARD	7 7/16 X 4 13/16	100	1	B.C. BOARD			
FLAP BD.				DIE CUT			
BOARD				DIE CUT			

DIE #	8598	METAL	6 RING MEMO	RADIUS	3/8"
ORDER #	864917	CUSTOMER	GERMANTOWN COPY	TEAR SEAL	.014
SHEET SIZE	7 X 5 1/2	STYLE CASE	VINYL BINDER	BAR SEAL	48-4
CAP.	1"	DUE DATE	10-12-08	COMPLETED	
LOCATION		QUANTITY	200	DATE	10-14-08

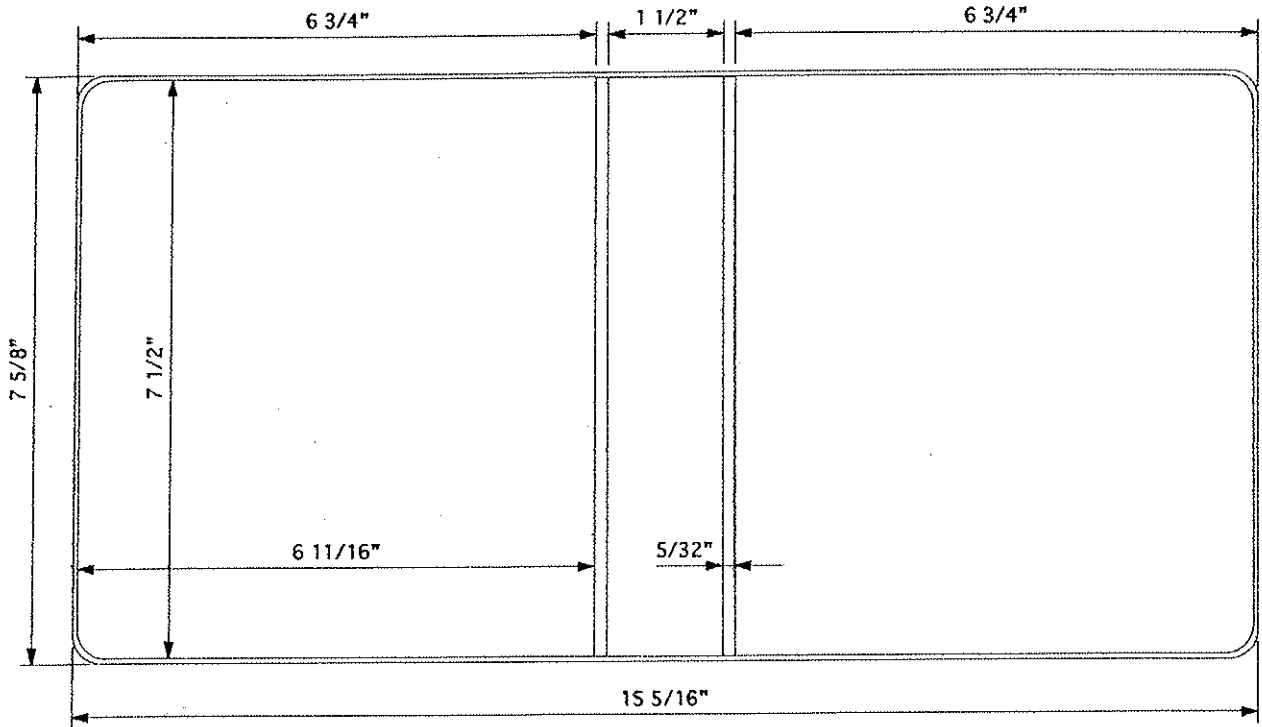

MATERIAL SPECS		GAUGE	PCS.	MATERIAL SPECS		GAUGE	PCS.				
COVER MAT.	8 3/8 X 16 1/8		1	LINING MAT.	8 3/8 X 16 1/8		1				
COVER MAT.				LINING MAT.							
DIE CUT				HORIZ. PKT.							
COL	7 3/4 X 16 1/8		1	VERT. PKT.							
LABEL HOLDER				DIE CUT							
GUSSET				REINF.							
BOARD SPECS		5/16" R. CORNERS		GAUGE	PCS.	BOARD SPECS		5/16" R. CORNERS		GAUGE	PCS.
F.C. BOARD	7 13/32 X 6 19/32	100	1	F.C. BOARD							
B.B. BOARD	7 13/32 X 1 13/32	100	1	B.B. BOARD							
B.C. BOARD	7 13/32 X 6 19/32	100	1	B.C. BOARD							
FLAP BD.				DIE CUT							
BOARD				DIE CUT							

DIE #	8717	METAL	RR (7 1/4 NB)	RADIUS	3/8"
ORDER #	899327	CUSTOMER	OLAN MILLS	TEAR SEAL	.014
SHEET SIZE	6 1/2 X 5 1/4	STYLE CASE	VINYL COL	BAR SEAL	48-4
CAP.	3/4"	DUE DATE	7-2-09	COMPLETED	
LOCATION		QUANTITY	1	DATE	6-26-09

*** WARNING DRAWING NOT ACTUAL SIZE ***

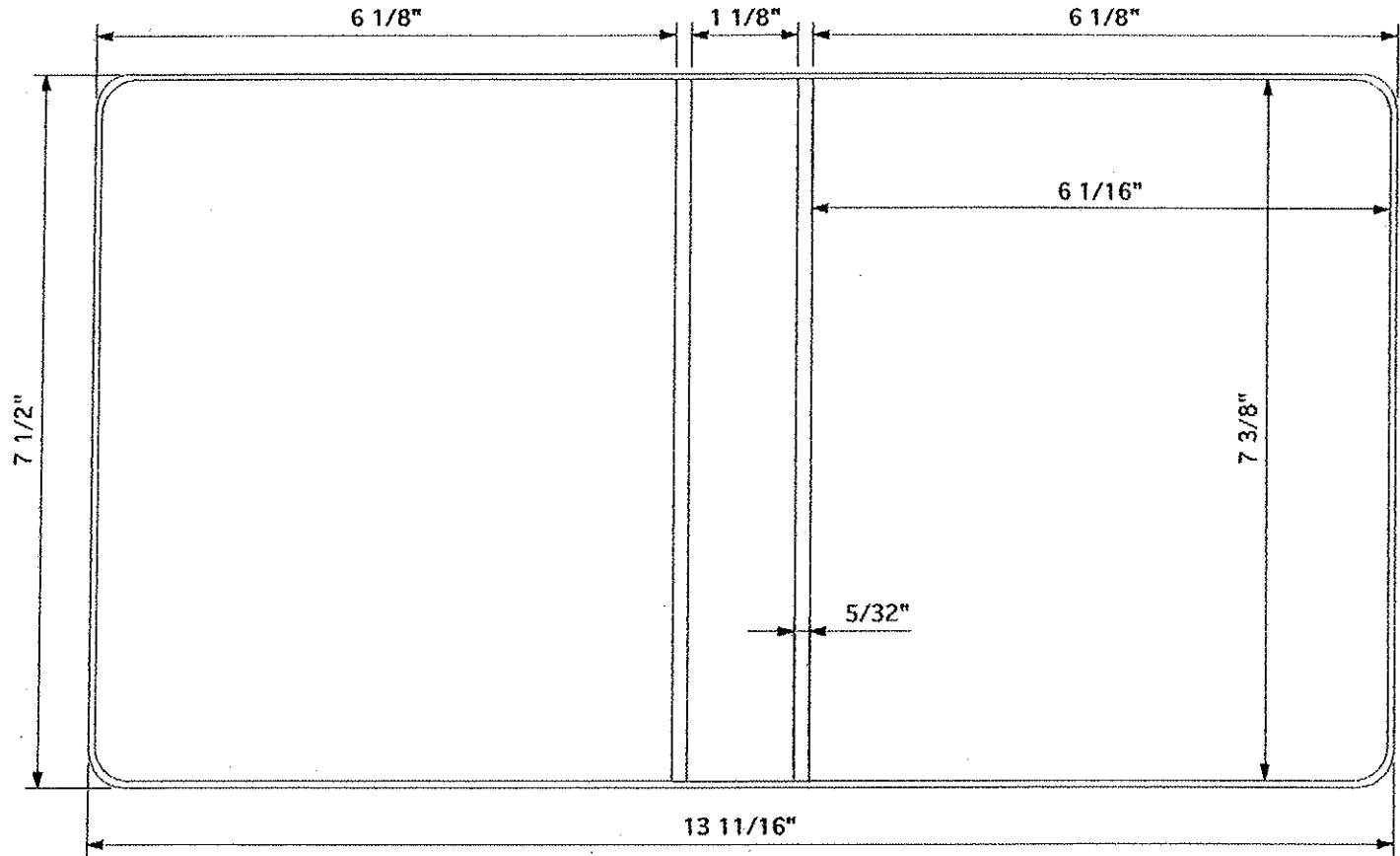

MATERIAL SPECS		GAUGE	PCS.	MATERIAL SPECS		GAUGE	PCS.
COVER MAT.	8 1/4 X 14 1/2		1	LINING MAT.	8 1/4 X 14 1/2		1
COVER MAT.				LINING MAT.			
DIE CUT				HORZ. PKT.			
COL	7 5/8 X 14 1/2		1	VERT. PKT.			
LABEL HOLDER				DIE CUT			
GUSSET				REINF.			
BOARD SPECS		GAUGE	PCS.	BOARD SPECS		GAUGE	PCS.
F.C. BOARD	7 5/16 X 6		1	F.C. BOARD			
B.B. BOARD	7 5/16 X 1 1/32		1	B.B. BOARD			
B.C. BOARD	7 5/16 X 6		1	B.C. BOARD			
FLAP BD.				DIE CUT			
BOARD				DIE CUT			