

Product Code

Style Case *Ring Binder*

Sheet Size $8\frac{1}{2} \times 14$ Cap. $2\frac{1}{2}$ Die No. *2224* Order No. *36135-2* Plate

Customer

Sample Makers Inc

Metal
Total Vinyl <i>.030</i>
Quantity <i>500</i>
Date <i>11-17-78</i>
Type Corners <i>RD</i>
Radius <i>1/4</i>
Completed

	Gauge	Thick
Tear Seal	<i>.016</i>	<i>3/32</i>
Bar Seal	<i>1/8</i>	<i>3/16</i>
Bar Seal		

	No. of Feet
Tear Seal	<i>7 1/2</i>
Bar Seal	<i>2</i>
Bar Seal	

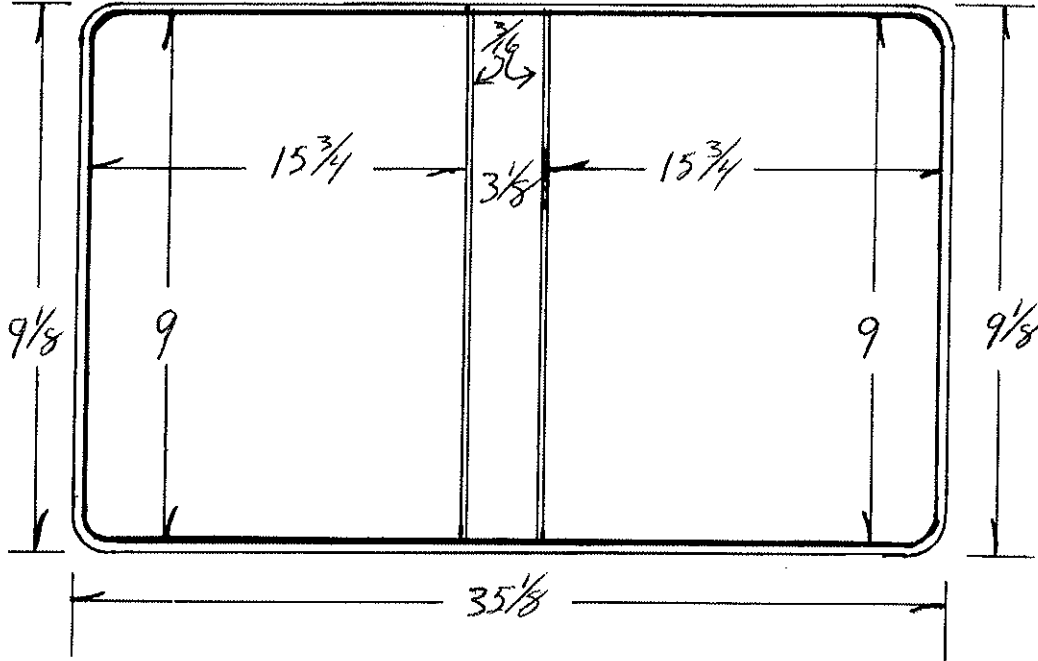

Code	Ga.	Pcs	Cutting Specs		Code	Ga.	Pcs.	Cutting Specs.	
			Size	Out				Size	Out
Cover Mat.			$9\frac{3}{4} \times 36$	1	Lining Mat.			$9\frac{3}{4} \times 36$	1
Cover Mat.			X		Lining Mat.			X	
Vert. Pckt.			X		Horz. Pckt.			X	
Vert. Pckt.			X		Horz. Pckt.			X	
Pocket			X		Pocket			X	
Label Holder			X		Card Holder			X	
Material			X		Material			X	
Material			X		Material			X	
Material			X		Material			X	
F.C. Board			$8\frac{15}{32} \times 15\frac{21}{32}$	1	B.C. Board			$8\frac{23}{32} \times 12\frac{21}{32}$	1
B.C. Board			$8\frac{15}{16} \times 15\frac{11}{16}$	2	B.B. Board			$8\frac{23}{32} \times 3\frac{1}{32}$	1
Center Board			$8\frac{15}{16} \times 3\frac{1}{32}$	1	Board			X	
Board			X		Strip			X	
Cover Pad			X		Strip			X	
					B.B. Pad			X	

Product Code

Style Case Ring Binder

Sheet Size 8 1/2 X 7 3/8 Cap. 2

Die No. 2319

Order No. 37956-0

Plate

VBI4 using
Customer

RBI INC.

Metal
Total Vinyl <u>1030</u>
Quantity <u>50</u>
Date <u>6-1-79</u>
Type Corners <u>rd</u>
Radius <u>1/4</u>
Completed

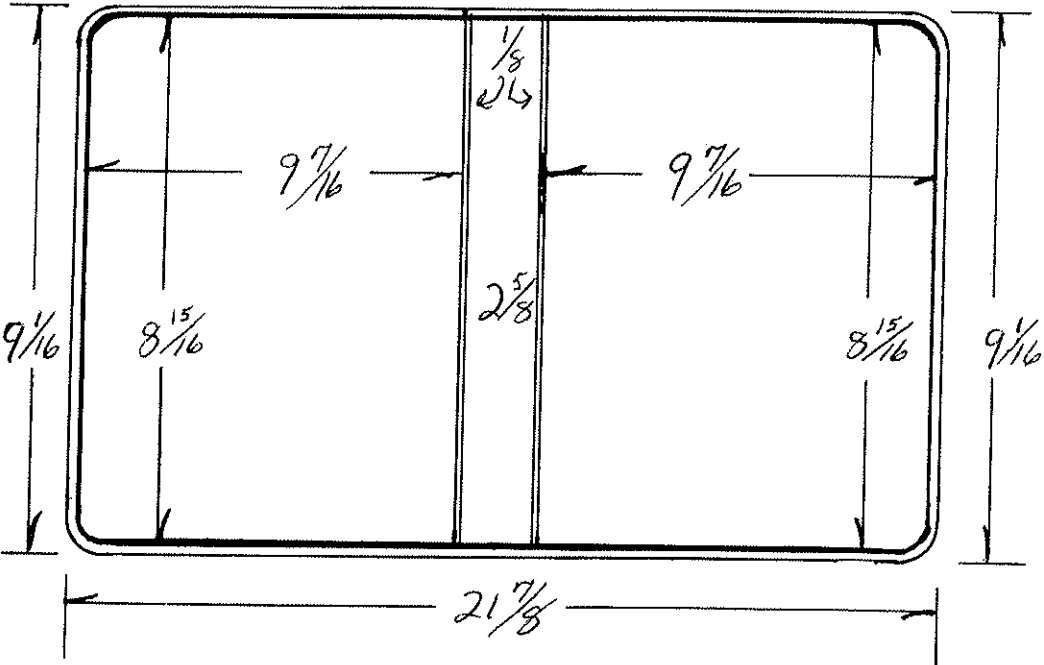

	Gauge	Thick
Tear Seal	<u>1016</u>	<u>3/32</u>
Bar Seal	<u>103</u>	<u>1/8</u>
Bar Seal		

	No. of Feet
Tear Seal	<u>5</u>
Bar Seal	<u>2</u>
Bar Seal	

Code	Ga.	# PCS	Cutting Specs		Code	Ga.	# Pcs.	Cutting Specs											
			Size	Out				Size	Out										
Cover Mat.			<u>9 1/16 X</u>	<u>22 5/8</u>	1					Lining Mat.			<u>9 1/16 X</u>	<u>22 5/8</u>	1				
Cover Mat			X							Lining Mat.			X						
Vert. Pckt.			X							Horz. Pckt.			X						
Vert. Pckt.			X							Horz. Pckt			X						
Pocket			X							Pocket			X						
Label Holder			X							Card Holder			X						
Material			X							Material			X						
Material			X							Material			X						
Material			X							Material			X						
F.C. Board			<u>8 1/2 X</u>	<u>9 1/32</u>	1					B.C. Board			<u>8 1/2 X</u>	<u>9 1/32</u>	1				
B.C. Board			X							B.B. Board			<u>8 1/2 X</u>	<u>2 1/32</u>	1				
Center Board			X							Board			X						
Board			X							Strip			X						
Cover Pad			X							Strip			X						
										B.B. Pad			X						

Product Code

Style Case Ring Binder

Sheet Size 8 1/2 X 7

Cap. 1 1/4

Die No. 7320

Order No. 37957-8

Plate

width same as 2" cap
Customer Die 2319

RBI INC.

Metal
Total Vinyl <u>1030</u>
Quantity <u>50</u>
Date <u>6-1-79</u>
Type Corners <u>RD</u>
Radius <u>1/4</u>
Completed

	Gauge	Thick
Tear Seal	<u>12/16</u>	<u>3/32</u>
Bar Seal	<u>103</u>	<u>1/8</u>
Bar Seal		

	No. of Feet
Tear Seal	<u>5</u>
Bar Seal	<u>2</u>
Bar Seal	

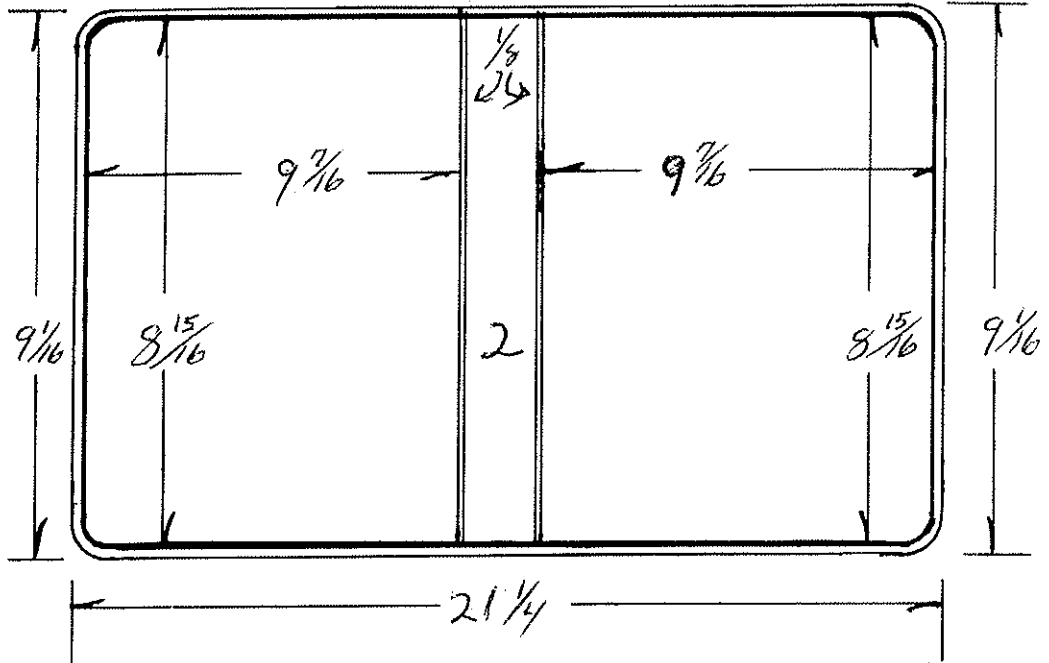

Code	Ga.	PCS	Cutting Specs		Code	Ga.	Pcs.	Cutting Specs	
			Size	Out				Size	Out
Cover Mat.		<u>1</u>			Lining Mat.		<u>1</u>		
Cover Mat.					Lining Mat.				
Vert. Pckt.					Horz. Pckt.				
Vert. Pckt.					Horz. Pckt.				
Pocket					Pocket				
Label Holder					Card Holder				
Material					Material				
Material					Material				
Material					Material				
F.C. Board		<u>1</u>			B.C. Board				
B.C. Board					B.B. Board		<u>1</u>		
Center Board					Board				
Board					Strip				
Cover Pad					Strip				
					B.B. Pad				

Product Code

Style Case Ring Binder

AS Sample

Sheet Size 8 1/2 X 4 5/8 Cap. 1/2 Die No. 2937 Order No. 16763-5 Plate

Customer

Security Lite of Denver

Metal
Total Vinyl .030
Quantity 250
Date 12-7-81
Type Corners Rd
Radius 1/4
Completed

	Gauge	Thick
Tear Seal	1016	3/32
Bar Seal	103	1/8
Bar Seal		

	No. of Feet
Tear Seal	
Bar Seal	
Bar Seal	

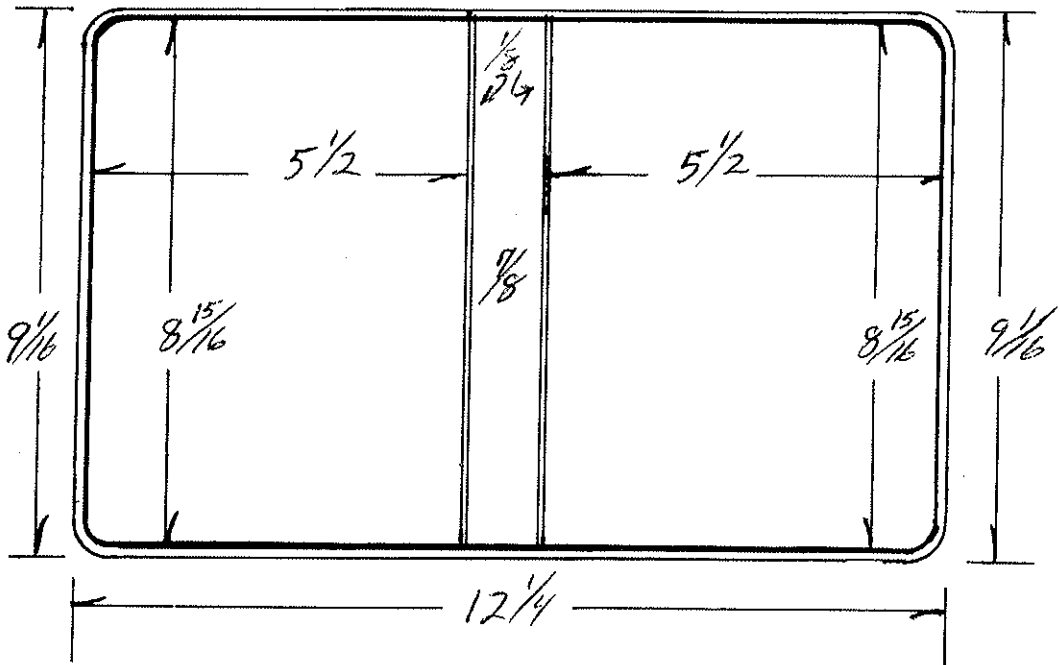

Code	Ga.	#	PCS	Cutting Specs		Code	Ga.	#	PCS	Cutting Specs	
				Size	Out					Size	Out
Cover Mat.			1	9 1/16 X	13	Lining Mat.			1	9 1/16 X	13
Cover Mat				X		Lining Mat.				X	
Vert. Pckt.				X		Horz. Pckt.				X	
Vert. Pckt.				X		Horz. Pckt.				X	
Pocket				X		Pocket				X	
Label Holder				X		Card Hlder				X	
Material				X		Material				X	
Material				X		Material				X	
Material				X		Material				X	
F.C. Board			120	8 27/32 X	5 13/32	B.C. Board			120	8 27/32 X	5 13/32
B.G. Board			100	8 7/8 X	5 7/16	B.B. Board			100	8 27/32 X	25/32
Center Board			100	8 7/8 X	25/32	Board				X	
Board				X		Strip				X	
Cover Pad				X		Strip				X	
						B.B. Pad				X	

Product Code

Style Case Ring Binder

Sheet Size $8\frac{1}{2} \times 5\frac{3}{4}$ Cap. $\frac{1}{2}$ Die No. 2802 Order No. Plate

Customer

sample: Ebsco Media

Metal
Total Vinyl .030
Quantity 1
Date
Type Corners Rd
Radius $\frac{1}{4}$
Completed

	Gauge	Thick
Tear Seal	1016	$\frac{3}{32}$
Bar Seal	103	$\frac{1}{8}$
Bar Seal		

	No. of Feet
Tear Seal	
Bar Seal	
Bar Seal	

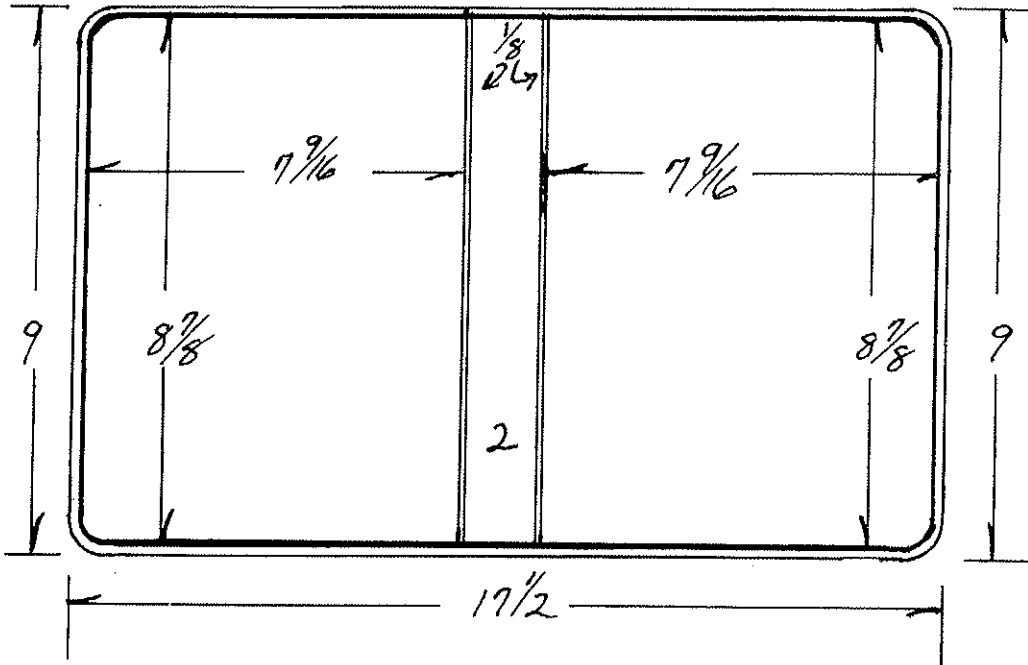

Code		Ga.	# PCS	Size	Out	Cutting Specs	Code		Ga.	# Pcs.	Size	Out	Cutting Specs.
Cover Mat.			1	$9\frac{5}{8} \times 18\frac{1}{4}$			Lining Mat.			1	$9\frac{5}{8} \times 18\frac{1}{4}$		
Cover Mat.	X						Lining Mat.	X					
Vert. Pckt.	X						Horz. Pckt.	X					
Vert. Pckt.	X						Horz. Pckt.	X					
Pocket	X						Pocket	X					
Label Holder	X						Card Hlder	X					
Material	X						Material	X					
Material	X						Material	X					
Material	X						Material	X					
F.C. Board			1	$8\frac{25}{32} \times 7\frac{15}{32}$			B.C. Board			1	$8\frac{25}{32} \times 7\frac{15}{32}$		
B.C. Board	X						B.B. Board			1	$8\frac{25}{32} \times 1\frac{29}{32}$		
Center Board	X						Board	X					
Board	X						Strip	X					
Cover Pad	X						Strip	X					
							B.B. Pad	X					

Product Code

Style Case King Binder

Sheet Size 8 1/2 X 9 Cap. 1 Die No. 2817 Order No. 18369-9 Plate

Customer

Eastern Business & Equipment

Metal
Total Vinyl .030
Quantity 100
Date 5-31-82
Type Corners RD
Radius 1/4
Completed

	Gauge	Thick
Tear Seal	.016	7/32
Bar Seal	178	7/16
Bar Seal		

	No. of Feet
Tear Seal	
Bar Seal	
Bar Seal	

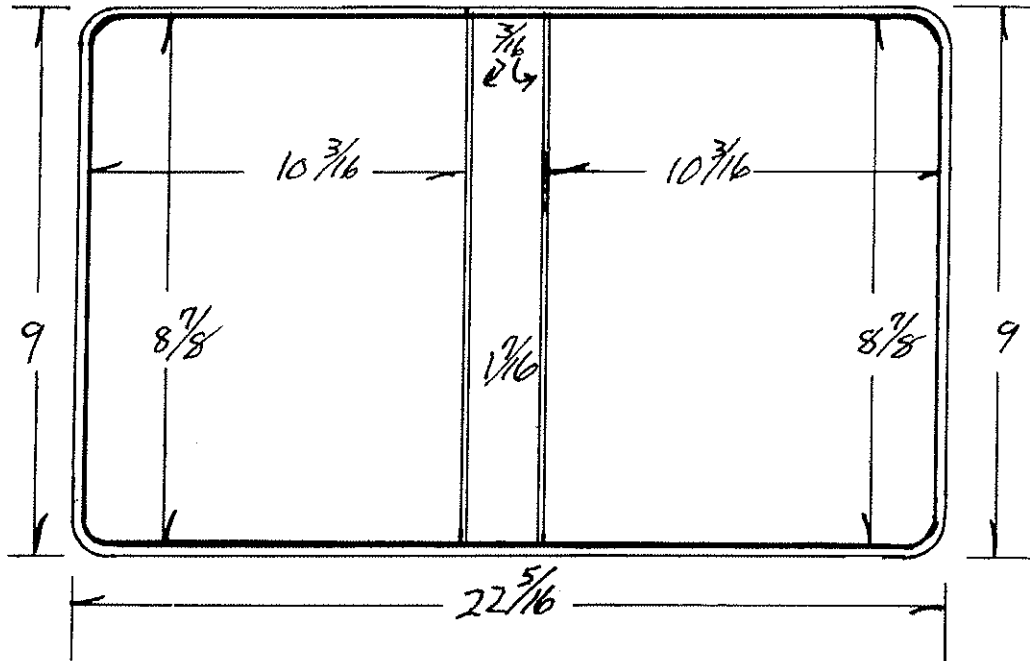

Code		Ga.	# PCS	Size	Cutting Specs	Out	Code		Ga.	# Pcs.	Size	Cutting Specs	Out
Cover Mat.				9 5/8 X 23 1/16			Lining Mat.				9 5/8 X 23 1/16		1
Cover Mat.				X			Lining Mat.				X		
Vert. Pckt.				X			Horz. Pckt.				9 1/16 X 22 15/16		1
Vert. Pckt.				X			Horz. Pckt.				X		
Pocket				X			Pocket				X		
Label Holder				X			Card Hlder				X		
Material				X			Material				X		
Material				X			Material				X		
Material				X			Material				X		
F.C. Board				8 25/32 X 10 3/32		1	B.C. Board				8 25/32 X 10 3/32		1
B.G. Board				X			B.B. Board				8 25/32 X 1 1/32		1
Center Board				X			Board				X		
Board				X			Strip				X		
Cover Pad				X			Strip				X		
							B.B. Pad				X		

Product Code QMI

Style Case Ring Binder

Sheet Size 8 7/8 X 15 1/8 Cap. 1 1/2

Die No. 3370

Order No. 949001

Plate

Customer

MUSIC Photo

7/18/85

Metal
Total Vinyl <u>.030</u>
Quantity <u>500</u>
Date <u>8-6-85</u>
Type Corners <u>Rd.</u>
Radius <u>1/4</u>
Completed

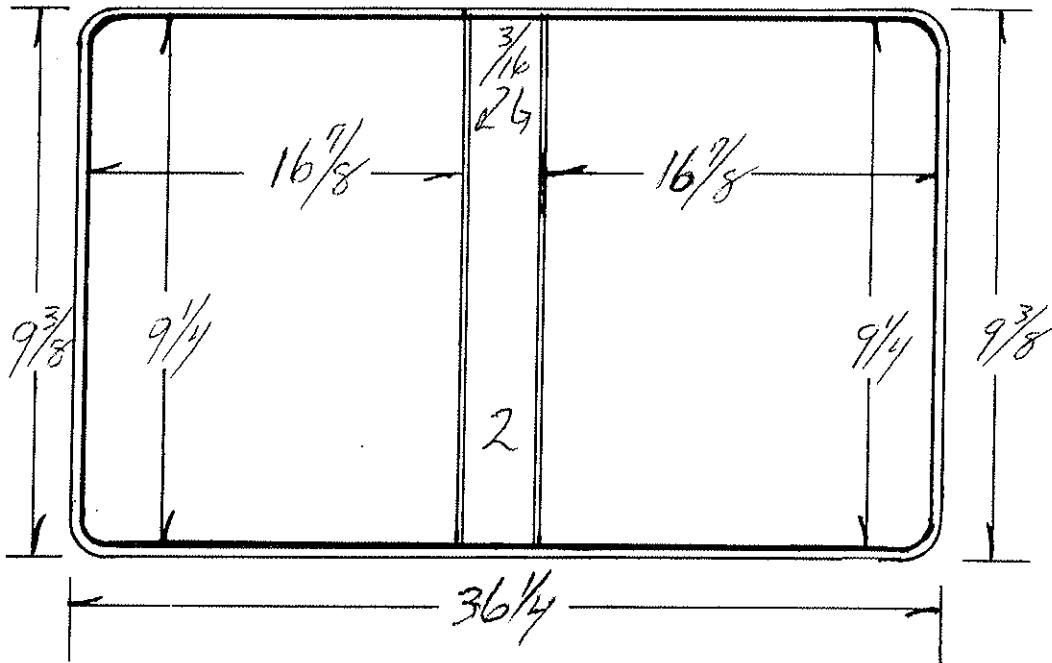

Gauge	Thick
Tear Seal <u>.016</u>	<u>3/32</u>
Bar Seal <u>178</u>	<u>3/16</u>
Bar Seal	

No. of Feet	
Tear Seal	
Bar Seal	
Bar Seal	

Code	Ga.	Pcs	Cutting Specs		Code	Ga.	Pcs	Cutting Specs				
			Size	Out				Size	Out			
Cover Mat.		<u>10</u>	X	<u>37</u>	Lining Mat.		<u>10</u>	X	<u>37</u>			
Cover Mat.			X		Lining Mat.			X				
Vert. Pckt.			X		Horz. Pckt.			X				
Vert. Pckt.			X		Horz. Pckt.			X				
Pocket			X		Pocket			X				
Label Holder			X		Card Hlder			X				
Material			X		Material			X				
Material			X		Material			X				
Material			X		Material			X				
F.C. Board		<u>9 3/32</u>	X	<u>16 3/32</u>	120	7	B.C. Board	<u>9 3/32</u>	X	<u>16 3/32</u>	120	1
B.C. Board		<u>9 3/16</u>	X	<u>16 13/16</u>	100	2	B.B. Board	<u>9 3/32</u>	X	<u>17 3/32</u>	120	1
Center Board			X				Board	<u>9 3/16</u>	X	<u>1 59/32</u>	100	1
Board			X		Strip			X				
Cover Pad			X		Strip			X				
					B.B. Pad			X				

Product Code

Style Case 1/2 I.B.C.

Sheet Size 8 1/2 X 7 1/2 Cap. 1 1/2 Die No. 3420 Order No. 950078 Plate

Customer

Clemens Markets

Metal
Total Vinyl <u>030</u>
Quantity <u>50</u>
Date <u>12-13-85</u>
Type Corners <u>Rd</u>
Radius <u>1/4</u>
Completed

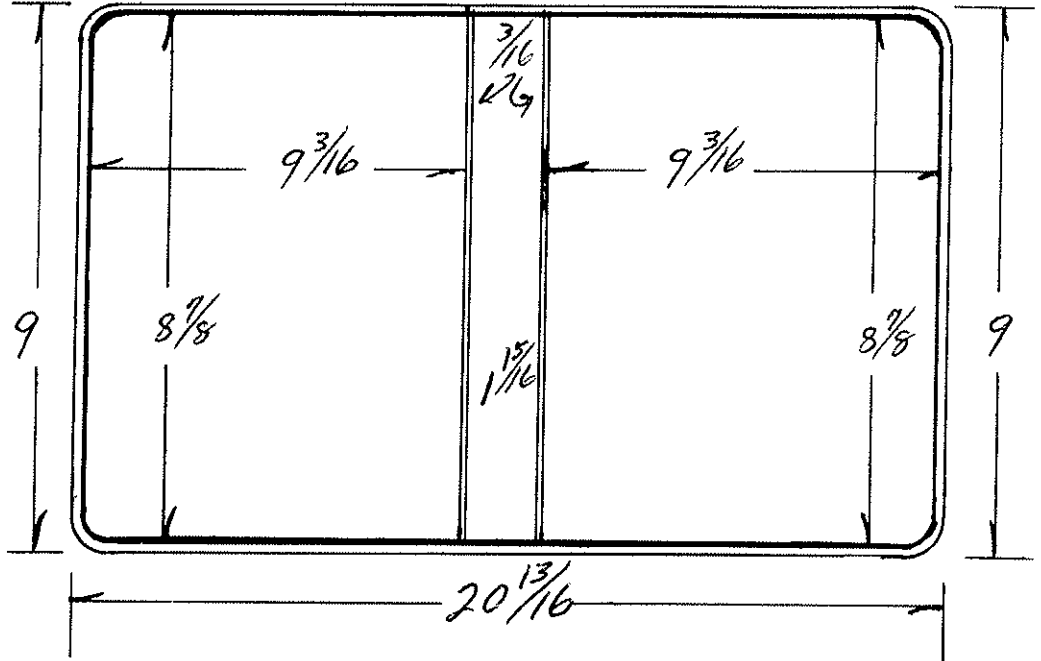

	Gauge	Thick
Tear Seal	<u>016</u>	<u>3/32</u>
Bar Seal	<u>178</u>	<u>3/16</u>
Bar Seal		

	No. of Feet
Tear Seal	
Bar Seal	
Bar Seal	

Code	Ga.	#	Cutting Specs		Code	Ga.	#	Cutting Specs		
			Size	Out				Size	Out	
Cover Mat.			<u>9 3/8 X 21 9/16</u>	<u>1</u>	Lining Mt.			<u>9 3/8 X 21 9/16</u>	<u>1</u>	
Cover Mat.			X		Lining Mat.			X		
Vert. Pckt.			X		Horz. Pckt.			X		
Vert. Pckt.			X		Horz. Pckt.			X		
Pocket			X		Pocket	<u>EX COL</u>		<u>9 1/8 X 12 3/8</u>		
Label Holder			X		Card Hlder			X		
Material			X		Material			X		
Material			X		Material			X		
Material			X		Material			X		
F.C. Board			<u>8 15/32 X 9 3/32</u>	<u>120</u>	<u>1</u>	B.C. Board		<u>8 27/32 X 9 3/32</u>	<u>120</u>	<u>1</u>
B.G. Board			X		B.B. Board			<u>8 27/32 X 12 27/32</u>	<u>120</u>	<u>1</u>
Center Board	<u>FC</u>		<u>8 13/16 X 9 1/8</u>	<u>100</u>	<u>2</u>	Board		X		
Board	<u>BH</u>		<u>8 13/16 X 12 27/32</u>	<u>100</u>	<u>1</u>	Strip		X		
Cover Pad			X		Strip			X		
					B.B. Pad			X		

Product Code

Style Case Ring Binder

Sheet Size 8³/₄ X 7¹/₂ Cap. 1

Die No. 3452

Order No. 950213

Plate

Customer

Adweek

Metal	
Total Vinyl	<u>.030</u>
Quantity	<u>50</u>
Date	<u>1-17-86</u>
Type Corners	<u>RD</u>
Radius	<u>1/4</u>
Completed	

	Gauge	Thick
Tear Seal	<u>.016</u>	<u>3/32</u>
Bar Seal	<u>178</u>	<u>3/16</u>
Bar Seal		

	No. of Feet
Tear Seal	
Bar Seal	
Bar Seal	

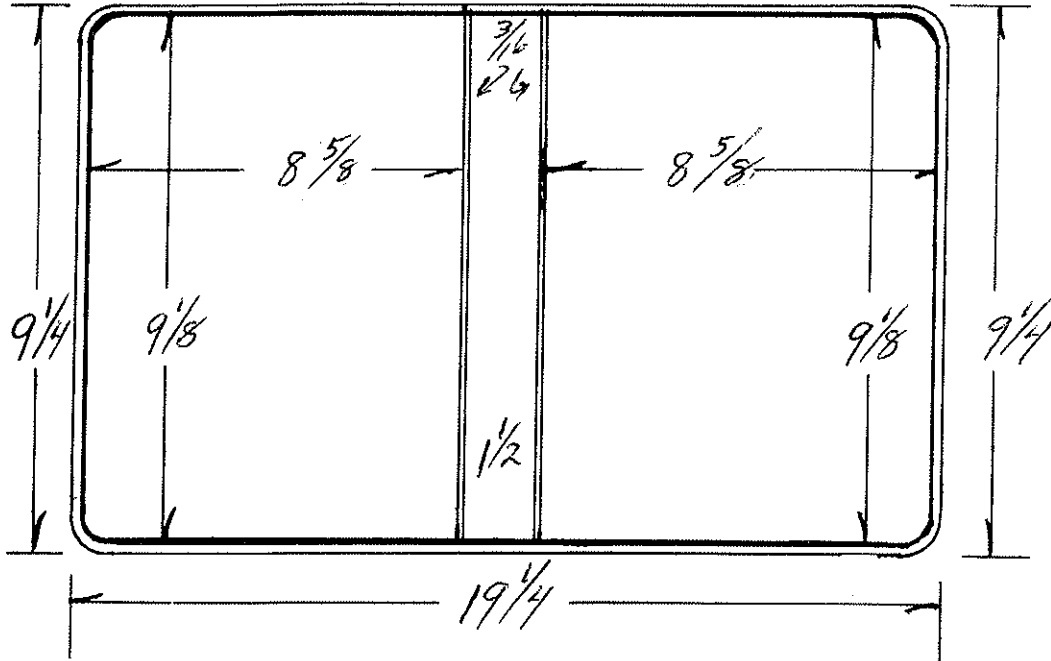

Code	Ga.	Pcs	Cutting Specs		Code	Ga.	Pcs	Cutting Specs	
			Size	Out				Size	Out
Cover Mat.		<u>9 7/8 X 20</u>		<u>1</u>	Lining Mat.		<u>9 7/8 X 20</u>		<u>1</u>
Cover Mat.		X			Lining Mat.		X		
Vert. Pckt.		X			Horz. Pckt.		X		
Vert. Pckt.		X			Horz. Pckt.		X		
Pocket		X			Pocket		X		
Label Holder		X			Card Holder		X		
Material		X			Material		X		
Material		X			Material		X		
Material		X			Material		X		
F.C. Board		<u>9 1/32 X 8 13/32</u>	<u>120</u>	<u>1</u>	B.C. Board		<u>9 1/32 X 8 13/32</u>	<u>120</u>	<u>1</u>
B.G. Board		<u>9 1/16 X 8 9/16</u>	<u>100</u>	<u>2</u>	B.B. Board		<u>9 1/32 X 1 13/32</u>	<u>120</u>	<u>1</u>
Center Board		<u>9 1/16 X 1 13/32</u>	<u>100</u>	<u>1</u>	Board		X		
Board		X			Strip		X		
Cover Pad		X			Strip		X		
					B.B. Pad		X		

Product Code O.A.F.C. 13^{3/4}

Style Case Ring Binder

Sheet Size 8^{1/2} X 12 Cap. 2^{1/2} Die No. 3621 Order No. 952913 Plate

Customer

Pickett Associates

Metal	
Total Vinyl	.030
Quantity	100
Date	9-19-86
Type Corners	Rd.
Radius	1/4
Completed	

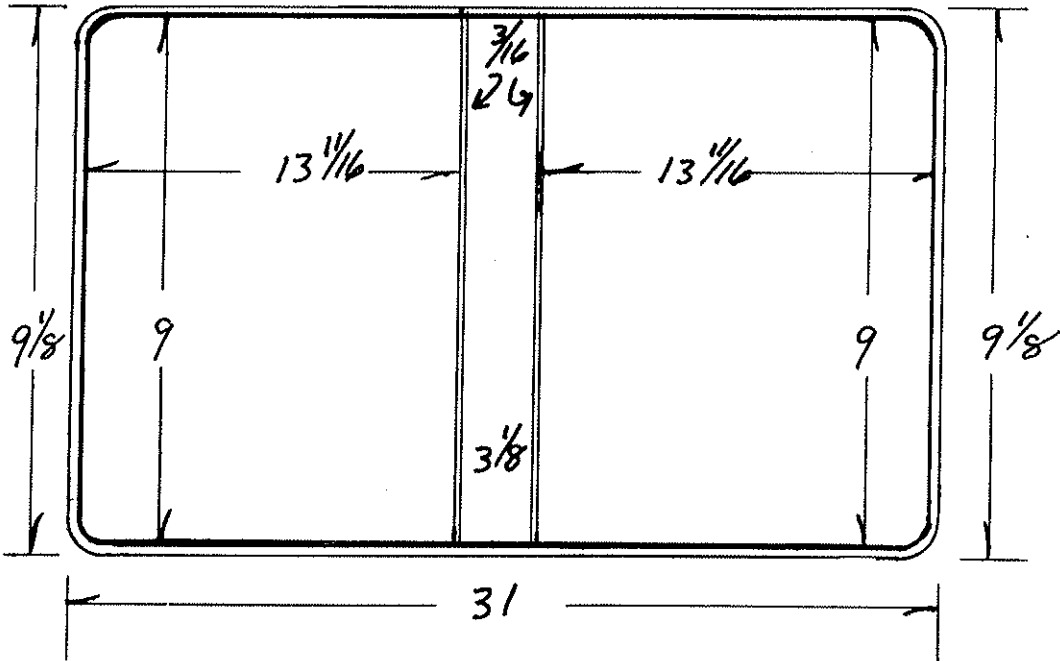

Gauge	Thick
Tear Seal	.016
Bar Seal	178
Bar Seal	3/16

No. of Feet
Tear Seal
Bar Seal
Bar Seal

Code	Ga.	#	Cutting Specs		Code	Ga.	#	Cutting Specs	
			Size	Out				Size	Out
Cover Mat.			9 3/4 X	31 3/4	Lining Mat.			9 3/4 X	31 3/4
Cover Mat.			X		Lining Mat.			X	
Vert. Pckt.			X		Horz. Pckt.			X	
Vert. Pckt.			X		Horz. Pckt.			X	
Pocket			X		Pocket			X	
Label Holder			X		Card Holder			X	
Material			X		Material			X	
Material			X		Material			X	
Material			X		Material			X	
F.C. Board			8 3/32 X	13 19/32	B.C. Board			8 3/32 X	13 19/32
B.C. Board			X	100	B.B. Board			8 3/32 X	3 1/32
Center Board			X		Board			X	
Board			X		Strip			X	
Cover Pad			X		Strip			X	
					B.B. Pad			X	

Product Code

Style Case *Rings Binder*

Sheet Size *AS Sample* X

Cap.

Die No. *3626*

Order No. *952951*

Plate

Customer

North Western Security Life Ins.

Metal
Total Vinyl <i>1030</i>
Quantity <i>1000</i>
Date <i>9-26-86</i>
Type Corners <i>Rd</i>
Radius <i>1/4</i>
Completed

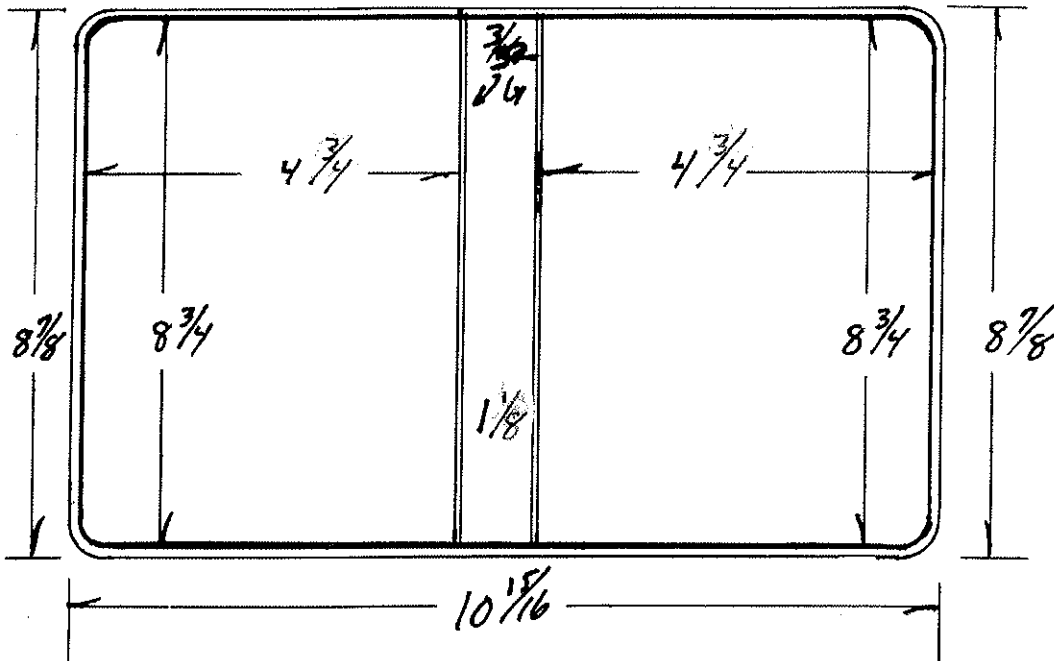

	Gauge	Thick
Tear Seal	<i>.016</i>	<i>3/32</i>
Bar Seal	<i>42</i>	<i>3/32</i>
Bar Seal		

	No. of Feet
Tear Seal	
Bar Seal	
Bar Seal	

Code	Ga.	PCS	Cutting Specs		Code	Ga.	Pcs.	Cutting Specs	
			Size	Out				Size	Out
Cover Mat.		<i>1</i>	<i>9 1/2 X 11 1/16</i>		Lining Mat.		<i>1</i>	<i>9 1/2 X 11 1/16</i>	
Cover Mat			X		Lining Mat.			X	
Vert. Pckt.			X		Horz. Pckt.			X	
Vert. Pckt.			X		Horz. Pckt.			X	
Pocket			X		Pocket			X	
Label Holder			X		Card Holder			X	
Material			X		Material			X	
Material			X		Material			X	
Material			X		Material			X	
F.C. Board		<i>1</i>	<i>8 3/32 X 4 1/32</i>		B.C. Board		<i>1</i>	<i>8 3/32 X 4 1/32</i>	
B.C. Board			X		B.B. Board		<i>1</i>	<i>8 3/32 X 1 1/32</i>	
Center Board			X		Board			X	
Board			X		Strip			X	
Cover Pad			X		Strip			X	
					B.B. Pad			X	

Product Code

Style Case *Ring Binder*

Sheet Size $8\frac{1}{2}$ X $14\frac{1}{2}$ Cap. 2 Die No. 3686 Order No. 953788 Plate

Customer

American Television + Communications

Metal
Total Vinyl .030
Quantity 50
Date 1-7-86
Type Corners R1
Radius 1/4
Completed

	Gauge	Thick
Tear Seal	.016	3/32
Bar Seal	178	3/16
Bar Seal		

	No. of Feet
Tear Seal	
Bar Seal	
Bar Seal	

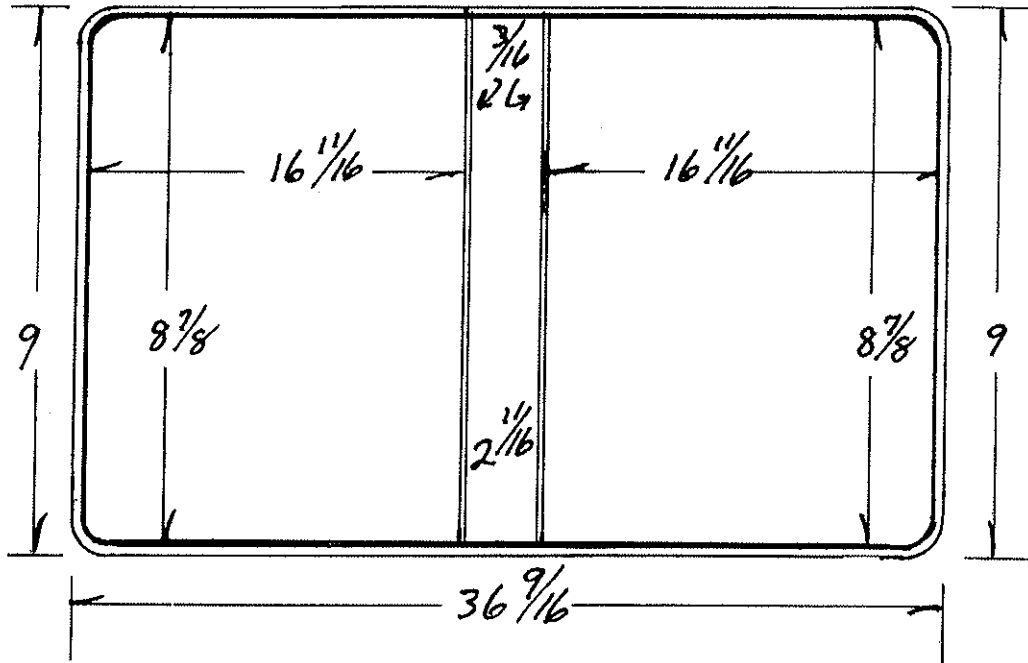

Code	Ga.	PCS	Cutting Specs		Code	Ga.	Pcs.	Cutting Specs	
			Size	Out				Size	Out
Cover Mat.		1	$9\frac{5}{8}$ X $37\frac{5}{16}$		Lining Mat.		1	$9\frac{5}{8}$ X $37\frac{5}{16}$	
Cover Mat.			X		Lining Mat.			X	
Vert. Pckt.			X		Horz. Pckt.			X	
Vert. Pckt.			X		Horz. Pckt.			X	
Pocket			X		Pocket			X	
Label Holder			X		Card Holder			X	
Material			X		Material			X	
Material			X		Material			X	
Material			X		Material			X	
F.C. Board		1	$8\frac{25}{32}$ X $16\frac{19}{32}$		B.C. Board		1	$8\frac{25}{32}$ X $16\frac{19}{32}$	
B.C. Board			X		B.B. Board		1	$8\frac{25}{32}$ X $2\frac{19}{32}$	
Panel Board		100	$8\frac{13}{16}$ X $16\frac{5}{8}$	2	Board			X	
Board (B)		1	$8\frac{13}{16}$ X $2\frac{5}{8}$		Strip			X	
Cover Pad			X		Strip			X	
					B.B. Pad			X	

Product Code as Sample

Style Case ^{Tuffy} Clear Ring Binder

Sheet Size 8 1/2 X 5 1/2 Cap. 1/2 Die No. 3689 Order No. 953688 Plate

Customer

Mercury Printing

Metal	
Total Vinyl	.030
Quantity	500
Date	12-10-86
Type Corners	Rd
Radius	1/4
Completed	

	Gauge	Thick
Tear Seal	.012	3/32
Bar Seal	178	3/16
Bar Seal		

	No. of Feet
Tear Seal	
Bar Seal	
Bar Seal	

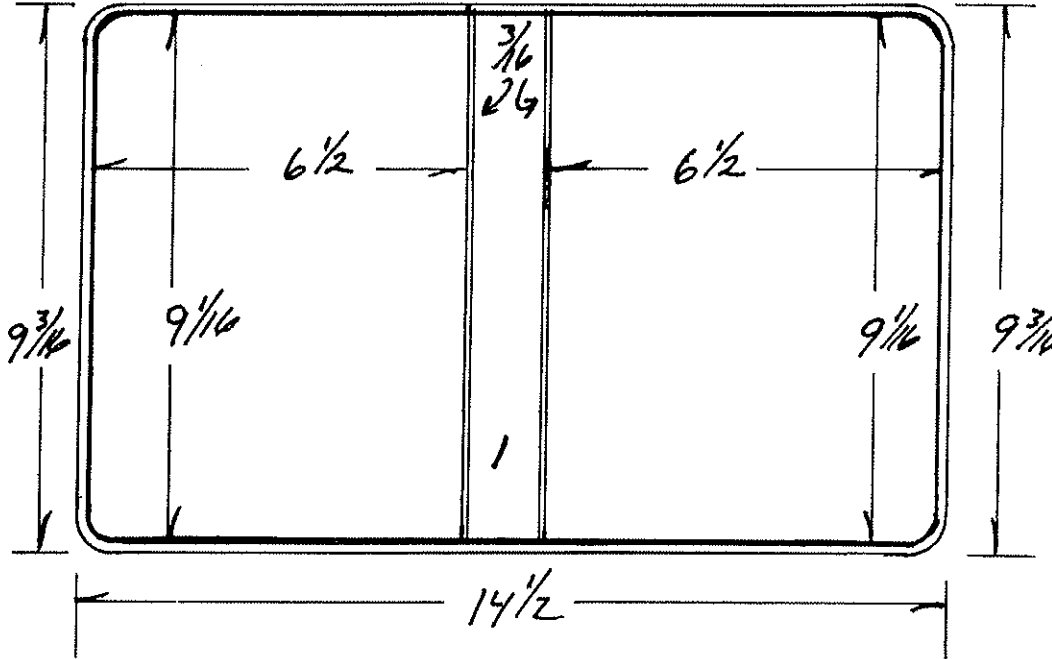

Code	Ga.	# PCS	Cutting Specs		Code	NO Lining	Ga.	# Pcs.	Cutting Specs	
			Size	Out					Size	Out
Cover Mat.		1	9 13/16 X 15 1/4		Lining Mat.		1			
Cover Mat.			X		Lining Mat.	X				
Vert. Pckt.			X		Horz. Pckt.	X				
Vert. Pckt.			X		Horz. Pckt.	X				
Pocket			X		Pocket	X				
Label Holder		1	9 3/16 X 1 3/8		Card Holder	X				
Material			X		Material	X				
Material			X		Material	X				
Material			X		Material	X				
F.C. Board			X		B.C. Board	X				
B.C. Board			X		B.B. Board	X				
Center Board			X		Board	X				
Board			X		Strip	X				
Cover Pad			X		Strip	X				
					B.B. Pad	X				

Product Code AS Sample

Style Case Rings Binder

Sheet Size 8 1/2 X 9 1/2 Cap. 1 1/4

Die No. 3748

Order No. 954516

Plate

Customer

Hewlett Packard

Metal
Total Vinyl <u>.030</u>
Quantity <u>7,200</u>
Date <u>7-18-87</u>
Type Corners <u>RD</u>
Radius <u>1/4</u>
Completed

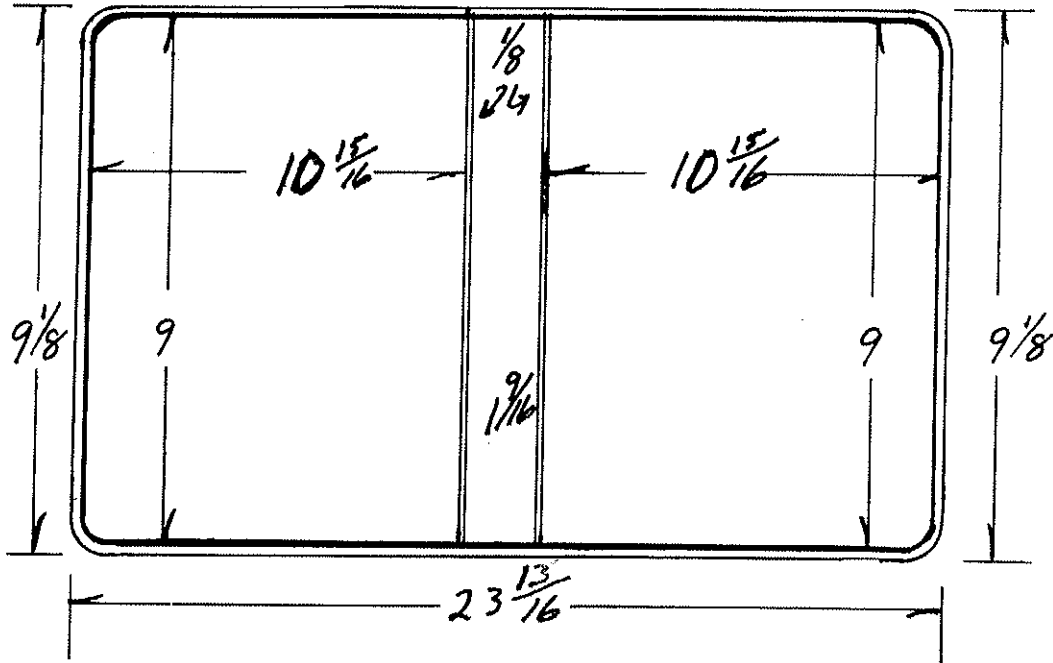

	Gauge	Thick
Tear Seal	<u>.016</u>	<u>3/32</u>
Bar Seal	<u>253</u>	<u>1/8</u>
Bar Seal		

	No. of Feet
Tear Seal	
Bar Seal	
Bar Seal	

Code	Ga.	PCS	Cutting Specs		Code	Ga.	Pcs.	Cutting Specs	
			Size	Out				Size	Out
Cover Mat.		<u>1</u>	<u>9 3/4 X 24 9/16</u>		Lining Mat.		<u>1</u>		
Cover Mat.			X		Lining Mat.			X	
Vert. Pckt.			X		Horz. Pckt.		<u>1</u>	<u>9 3/16 X 24 7/16</u>	
Vert. Pckt.			X		Horz. Pckt.			X	
Pocket			X		Pocket			X	
Label Holder			X		Card Holder			X	
Material			X		Material			X	
Material			X		Material			X	
Material			X		Material			X	
F.C. Board		<u>120</u>	<u>1</u>	<u>8 29/32 X 10 27/32</u>	B.C. Board		<u>120</u>	<u>1</u>	<u>8 29/32 X 10 27/32</u>
B.C. Board		<u>100</u>	<u>2</u>	<u>8 15/16 X 10 7/8</u>	B.B. Board		<u>120</u>	<u>1</u>	<u>8 29/32 X 1 15/32</u>
Center Board	<u>BD</u>	<u>100</u>	<u>1</u>	<u>8 15/16 X 1 1/2</u>	Board			X	
Board			X		Strip			X	
Cover Pad			X		Strip			X	
					B.B. Pad			X	

Product Code

Style Case K.R.B.

Sheet Size 8 1/2 x 11 5/8 Cap. 1 Die No. 3899 Order No. 956856 Plate

Customer First Alabama Bank of Hustsville

Metal
Total Vinyl
Quantity <u>400</u>
Date
Type Corners <u>Rd</u>
Radius <u>1/4</u>
Completed

	Gauge	Thick
Tear Seal	<u>16</u>	<u>2/32</u>
Bar Seal	<u>162</u>	<u>2/32</u>
Bar Seal		

	No. of Feet
Tear Seal	
Bar Seal	
Bar Seal	

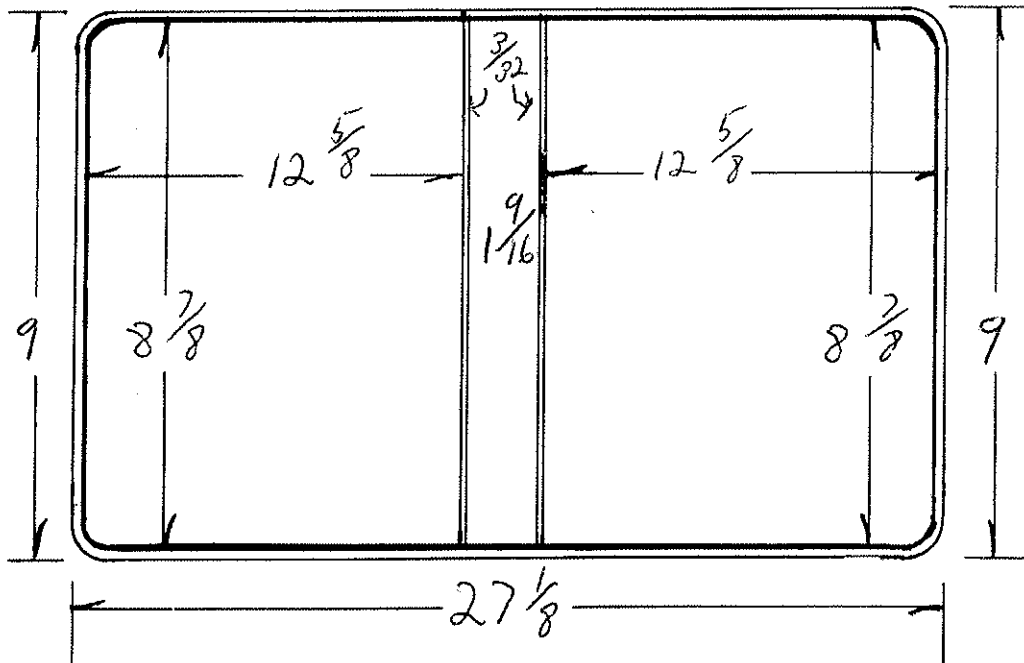

Code	Cutting Specs				Code	Cutting Specs			
	Ga.	PCS	Size	Out		Ga.	PCS	Size	Out
Cover Mat.		1	9 5/8 x 27 7/8		Lining Mat.	1	9 5/8 x 27 7/8		
Cover Mat.			X		Lining Mat.		X		
Vert. Pckt.			X		Horz. Pckt.		X		
Vert. Pckt.			X		Horz. Pckt.		X		
Pocket			X		Pocket		X		
Label Holder			X		Card Holder		X		
Material			X		Material		X		
Material			X		Material		X		
Material			X		Material		X		
F.C. Board		1	8 25/32 x 12 17/32		B.C. Board	1	8 25/32 x 12 17/32		
B.C. Board			X		B.B. Board	1	8 25/32 x 1 17/32		
Center Board			X		Board		X		
Board			X		Strip		X		
Cover Pad			X		Strip		X		
					B.B. Pad		X		

Product Code

Old 1338

Style Case Ring Binder

Sheet Size 8 1/2 X 11 1/2 Cap. 1

Die No. 3848

Order No. 956163

Plate

Customer

Southern Co. Services

Metal
Total Vinyl .030
Quantity 50
Date 7-23-87
Type Corners RD
Radius 1/4
Completed

	Gauge	Thick
Tear Seal	.016	3/32
Bar Seal	102	3/32
Bar Seal		

	No. of Feet
Tear Seal	
Bar Seal	
Bar Seal	

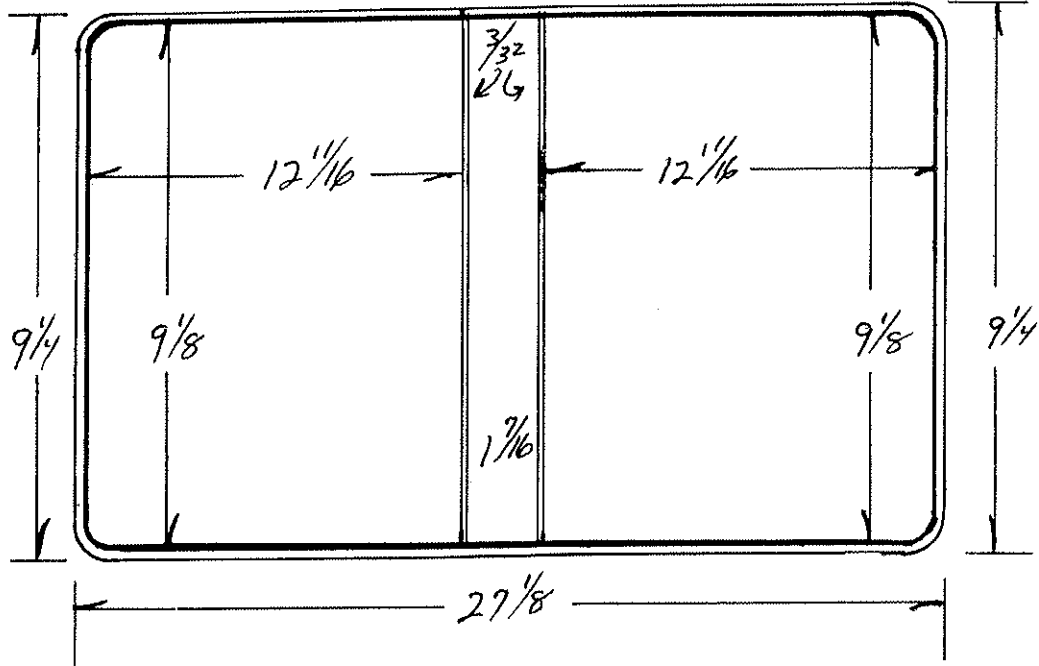

Code	Cutting Specs				Code	Cutting Specs			
	Ga.	Pcs	Size	Out		Ga.	Pcs	Size	Out
Cover Mat.			9 7/8 X 27 7/8	1	Lining Mat.			9 7/8 X 27 7/8	1
Cover Mat.			X		Lining Mat.			X	
Vert. Pckt.			X		Horz. Pckt.			9 5/16 X 14 1/16	1
Vert. Pckt.			X		Horz. Pckt.			X	
Pocket			X		Pocket			X	
Label Holder			X		Card Holder			X	
Material			X		Material			X	
Material			X		Material			X	
Material			X		Material			X	
F.C. Board			9 1/32 X 12 19/32	120 1	B.C. Board			9 1/32 X 12 19/32	120 1
B.C. Board			X		B.B. Board			9 1/32 X 1 11/32	120 1
Center Board			9 1/16 X 12 5/8	100 2	Board			X	
Board			9 1/16 X 1 1/32	100 1	Strip			X	
Cover Pad			X		Strip			X	
					B.B. Pad			X	

Product Code

Style Case Ring Binder 8 1/2 in

Sheet Size 8 X 5 1/4 Cap. 1/2 Die No. 3942 Order No. 957671 Plate

Customer

National Insta Print + office Supply

Metal
Total Vinyl .024
Quantity 130
Date 1-4-87
Type Corners Rd.
Radius 1/4
Completed

	Gauge	Thick
Tear Seal	.012	3/32
Bar Seal	102	3/32
Bar Seal		

	No. of Feet
Tear Seal	
Bar Seal	
Bar Seal	

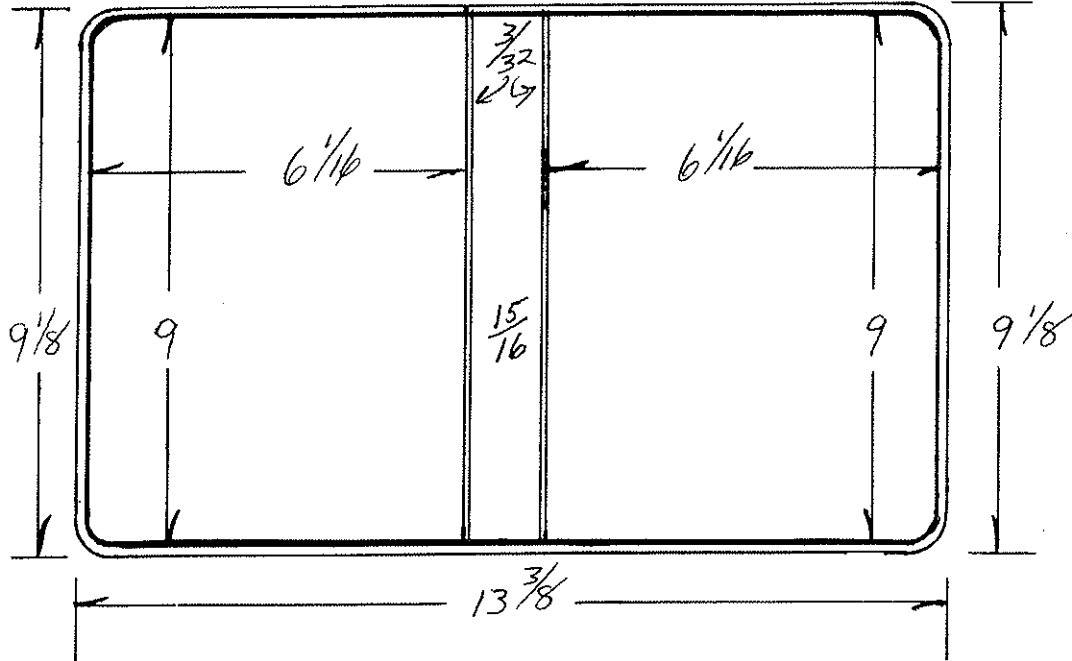

Code	Ga.	# PCS	Cutting Specs		Code	Ga.	# Pcs.	Cutting Specs	
			Size	Out				Size	Out
Cover Mat.		1	9 3/4 X 14 1/8		Lining Mat.		1	9 3/4 X 14 1/8	
Cover Mat			X		Lining Mat.			X	
Vert. Pckt.			X		Horz. Pckt.			X	
Vert. Pckt.			X		Horz. Pckt.			X	
Pocket			X		Pocket			X	
Label Holder			X		Card Holder			X	
Material			X		Material			X	
Material			X		Material			X	
Material			X		Material			X	
F.C. Board		1	8 29/32 X 5 31/32		B.C. Board		1	8 29/32 X 5 31/32	
B.C. Board			X		B.B. Board		1	8 29/32 X 2 7/32	
Center Board			X		Board			X	
Board			X		Strip			X	
Cover Pad			X		Strip			X	
					B.B. Pad			X	

Product Code

Style Case

Sheet Size $8\frac{1}{2} \times 7$ Cap. 2

Die No. 3958

Order No. 957658 Plate

Customer Miller Printing

Metal
Total Vinyl
Quantity
Date
Type Corners Ad
Radius $\frac{1}{4}$
Completed

	Gauge	Thick
Tear Seal	16	32
Bar Seal	107	222
Bar Seal		

	No. of Feet
Tear Seal	
Bar Seal	
Bar Seal	

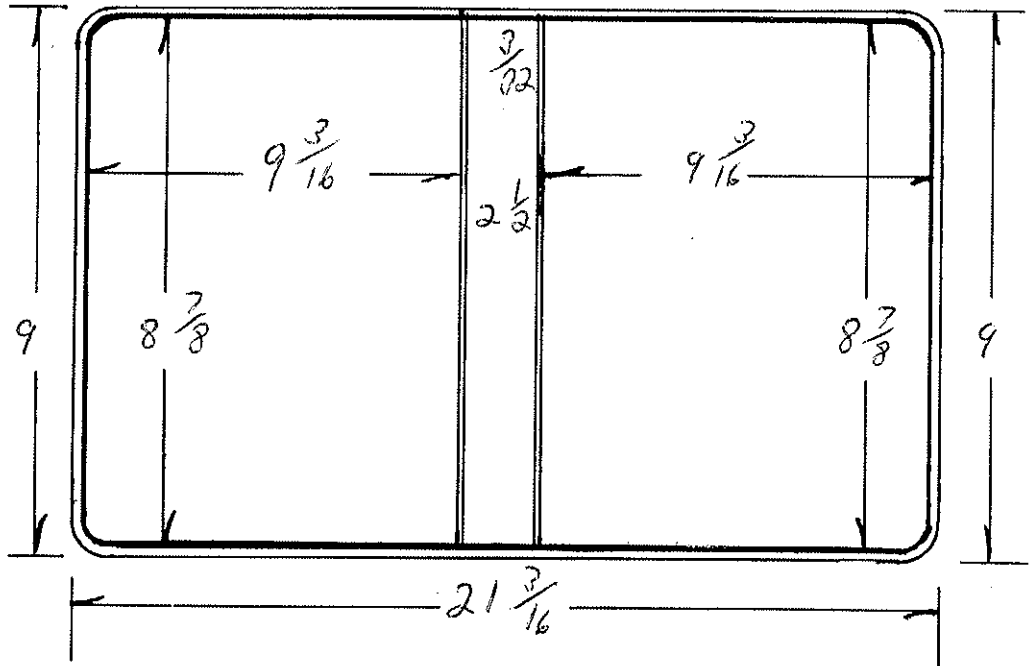

Code	Ga.	#	Cutting Specs		Code	Ga.	#	Cutting Specs	
			Size	Out				Size	Out
Cover Mat.			$9\frac{5}{8} \times 21\frac{15}{16}$	1	Lining Mat.			$9\frac{5}{8} \times 21\frac{15}{16}$	1
Cover Mat			X		Lining Mat.			X	
Vert. Pckt.			X		Horz. Pckt.			X	
Vert. Pckt.			X		Horz. Pckt.			X	
Pocket			X		Pocket			X	
Label Holder			X		Card Holder			X	
Material			X		Material			X	
Material			X		Material			X	
Material			X		Material			X	
F.C. Board			$8\frac{25}{32} \times 9\frac{3}{32}$	1	B.C. Board			$8\frac{25}{32} \times 9\frac{3}{32}$	1
B.C. Board			X		B.B. Board			$8\frac{25}{32} \times 2\frac{13}{32}$	1
Center Board			X		Board			X	
Board			X		Strip			X	
Cover Pad			X		Strip			X	
					B.B. Pad			X	

Product Code

Style Case

VRB

Sheet Size $8\frac{1}{2}$ x $14\frac{1}{2}$ Cap. $\frac{3}{4}$

Die No. 4100

Order No. 961152.1

Plate

Customer FORMS DESIGN

Metal
Total Vinyl
Quantity 50
Date 12-9-88
Type Corners RND.
Radius $\frac{3}{16}$
Completed

	Gauge	Thick
Tear Seal	.016	$\frac{1}{16}$
Bar Seal	728	$\frac{5}{32}$
Bar Seal		

	No. of Feet
Tear Seal	
Bar Seal	
Bar Seal	

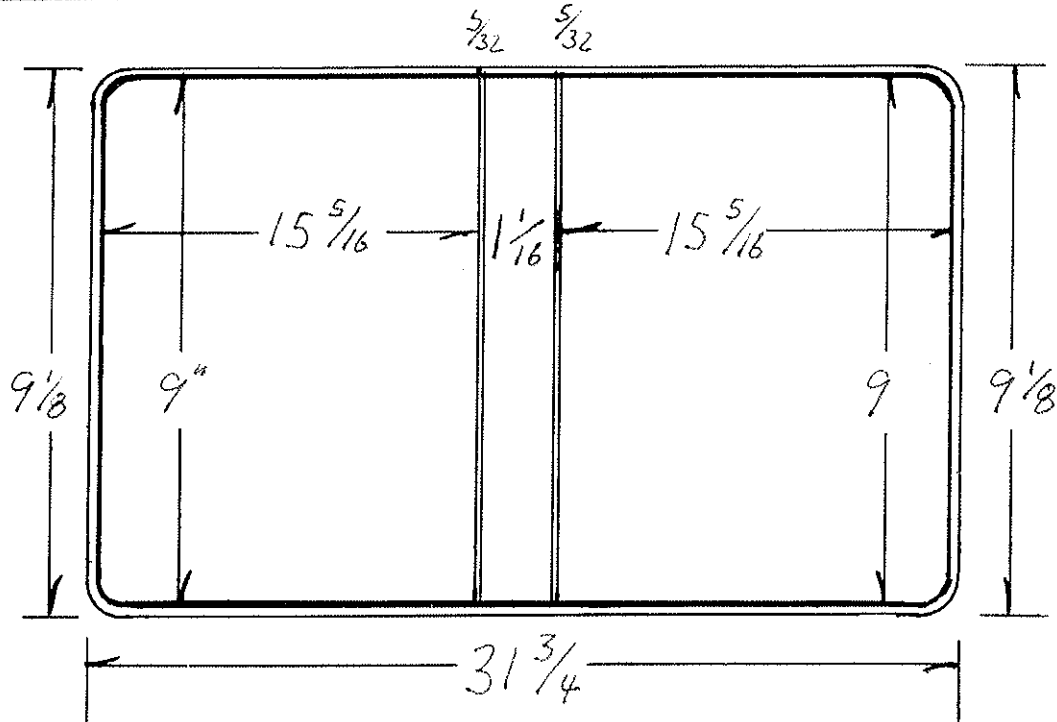

Code	Ga.	PCS	Cutting Specs		Code	Ga.	Pcs.	Cutting Specs							
			Size	Out				Size	Out						
Cover Mat.			$9\frac{3}{4}$	X	$32\frac{1}{2}$	15	1	Lining Mat.			$9\frac{3}{4}$	X	$32\frac{1}{2}$	15	1
Cover Mat.				X				Lining Mat.				X			
Vert. Pckt.				X				Horz. Pckt.				X			
Vert. Pckt.				X				Horz. Pckt.				X			
Pocket				X				Pocket				X			
Label Holder				X				Card Holder				X			
Material				X				Material				X			
Material				X				Material				X			
Material				X				Material				X			
F.C. Board			$8\frac{27}{32}$	X	$15\frac{7}{32}$	100	1	B.C. Board				X			
B.C. Board			"	X	"	"	"	B.B. Board			$3\frac{1}{32}$	X	$8\frac{27}{32}$	100	1
Center Board				X				Board				X			
Board				X				Strip				X			
Cover Pad				X				Strip				X			
								B.B. Pad				X			

Product Code

Style Case

VRB

Sheet Size $8\frac{1}{2}$ x $11\frac{1}{2}$ Cap. $1\frac{1}{2}$ Die No. 4269

Order No. 963462

Plate

Customer

NEW IMAGE

Metal
Total Vinyl
Quantity 150
Date 8-25-89
Type Corners RND
Radius $\frac{3}{8}$ "
Completed

	Gauge	Thick
Tear Seal	.016	$\frac{3}{32}$
Bar Seal	#254	$\frac{5}{32}$
Bar Seal		

	No. of Feet
Tear Seal	
Bar Seal	
Bar Seal	

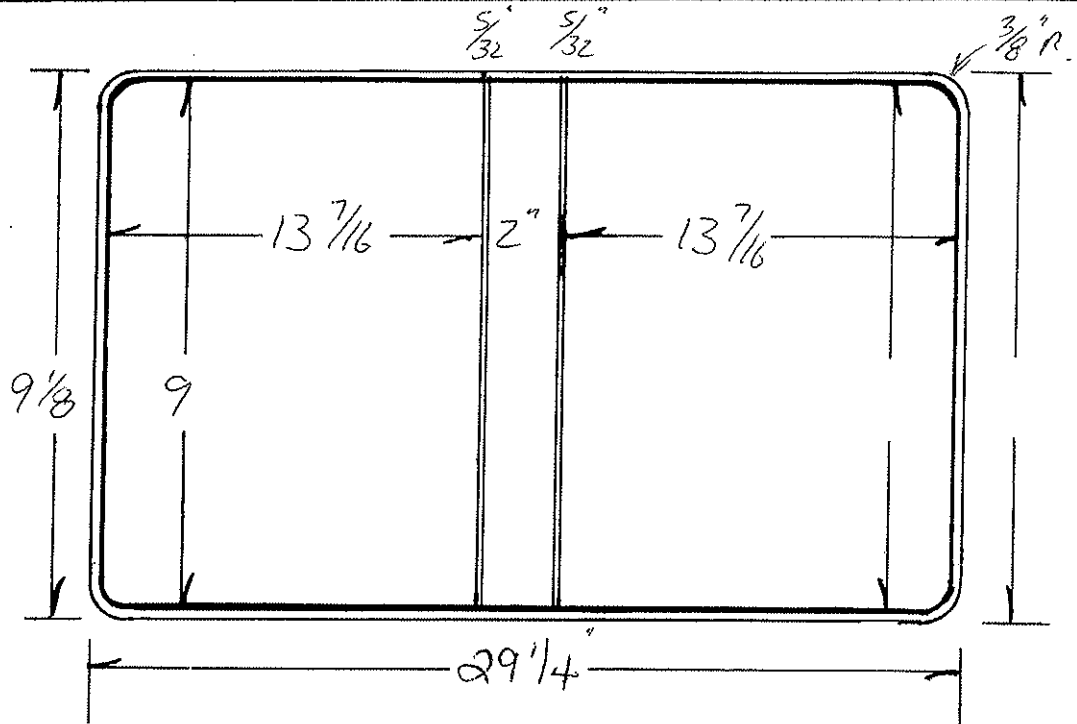

Code	Ga.	PCS	Cutting Specs		Code	Ga.	Pcs.	Spec Tin Cutting Specs.	
			Size	Out				Size	Out
Cover Mat.	10	X	$30\frac{1}{16}$	15	Lining Mat.	10	X	$30\frac{1}{16}$	15
Cover Mat.		X			Lining Mat.		X		
Vert. Pckt.		X			Horz. Pckt.		X		
Vert. Pckt.		X			Horz. Pckt.		X		
Pocket		X			Pocket		X		
Label Holder		X			Card Holder		X		
Material		X			Material		X		
Material		X			Material		X		
Material		X			Material		X		
F.C. Board		$8\frac{29}{32}$	X	$13\frac{1}{32}$	B.C. Board		$8\frac{11}{16}$	X	$13\frac{3}{8}$
B.C. Board		$8\frac{29}{32}$	X	$13\frac{1}{32}$	B.B. Board		$8\frac{11}{16}$	X	$12\frac{29}{32}$
Center Board		$8\frac{29}{32}$	X	$12\frac{29}{32}$	Board		$8\frac{11}{16}$	X	$13\frac{3}{8}$
Board		X			Strip		X		
Cover Pad		X			Strip		X		
					B.B. Pad		X		

Product Code

OLD# 728

Style Case

VRB

Sheet Size

8 1/2 X 11 1/2

Cap. 1

Die No. 4310

Order No. 963727

Plate

Customer

LALA

Metal
Total Vinyl
Quantity
Date
Type Corners
Radius 3/8
Completed 10-25-89 RET

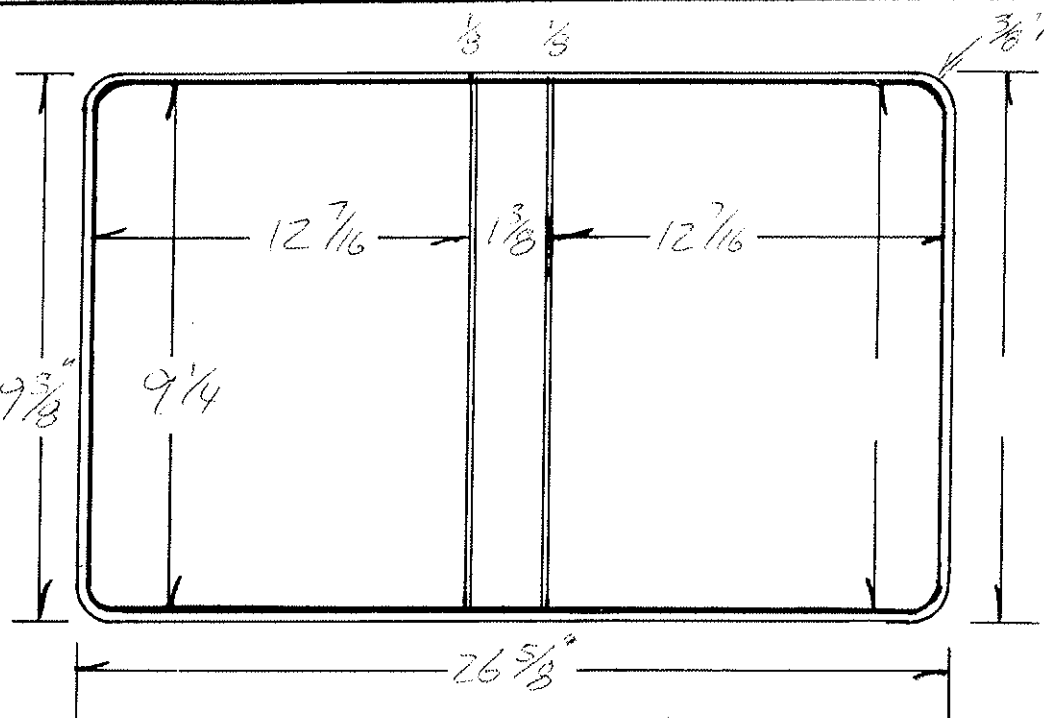

Gauge	Thick
Tear Seal 1016	1/16"
Bar Seal 4253	1/8"
Bar Seal	

No. of Feet	
Tear Seal	
Bar Seal	
Bar Seal	

10-25-89

SIZE BY: B.P.

CHECK BY: *KP*

Code	Ga.	PCS	Cutting Specs		Code	Ga.	Pcs.	Cutting Specs	
			Size	Out				Size	Out
Cover Mat.			10 1/4 X	27 1/2	15	1			
Cover Mat.			X		Lining Mat.			10 1/4 X	27 1/2
Vert. Pckt.			X		Lining Mat.			X	
Vert. Rckt.			X		Horz. Pckt. 1-SIDE			X	12 7/16
Pocket			X		Horz. Pckt.			X	
Label Holder			X		Pocket			X	
Material			X		Card Holder			X	
Material			X		Material			X	
Material			X		Material			X	
F.C. Board			X		Material			X	
B.C. Board			9 5/32 X	12 1/32	B.C. Board			X	
Center Board			9 5/32 X	12 1/32	B.B. Board			9 7/32 X	1 1/32
Board			9 3/16 X	12 3/8	Board			9 3/16 X	1 9/32
Cover Pad			X		Strip			X	
					Strip			X	
					B.B. Pad			X	

Product Code

OLD # 777

Style Case

VRB

Sheet Size 8 1/2 x 11 1/2 Cap. 1/2

Die No. 4476

Order No.

Plate

Customer

STOCK

Metal
Total Vinyl
Quantity
Date 7-13-90
Type Corners
Radius 3/8"
Completed 7-13-90

	Gauge	Thick
Tear Seal	.014	1/16"
Bar Seal	#253	1/8"
Bar Seal		

	No. of Feet
Tear Seal	
Bar Seal	
Bar Seal	

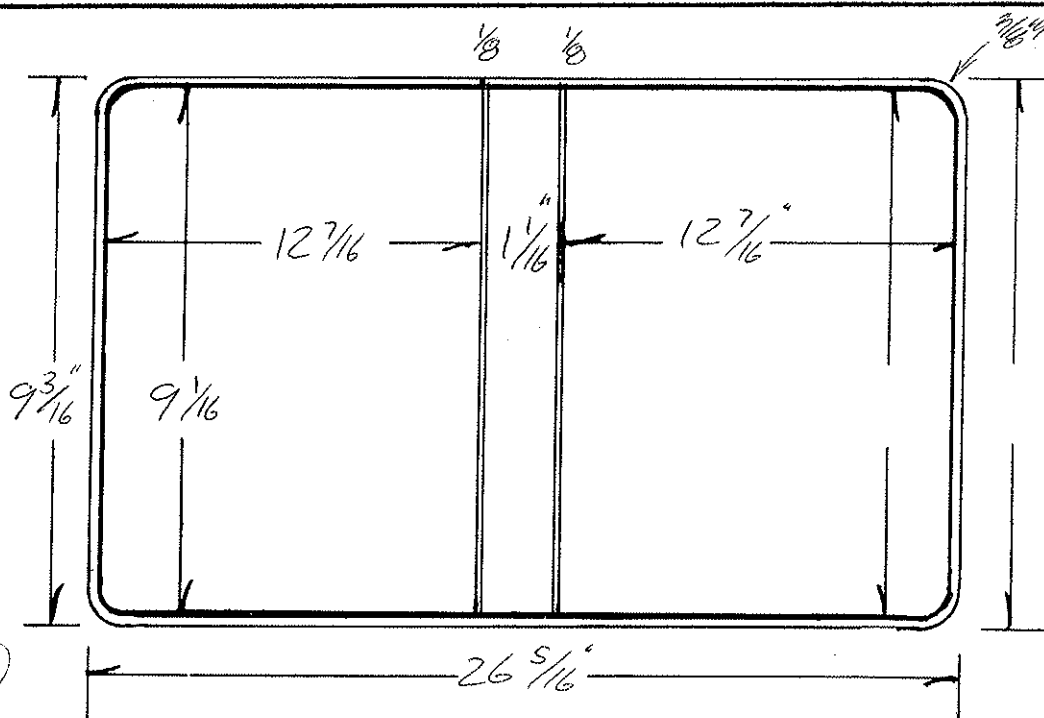

SIZE - B.Pac

CHECK

KPW
Calculations only

Code	Ga.	# PCS	Cutting Specs		Code	Ga.	# Pcs.	Cutting Specs	
			Size	Out				Size	Out
Cover Mat.		14	9 3/4 X 27 1/8		Lining Mat.	14	1	9 3/4 X 27 1/8	
Cover Mat.			X		Lining Mat.			X	
Vert. Pckt.			X		Horz. Pckt. 1-SIDE		1	4 3/8 X 13	
Vert. Pckt.			X		Horz. Pckt. 2-SIDE		1	4 3/8 X 27 1/8	
Pocket			X		Pocket			X	
Label Holder			X		Card Holder FULL			X	
Material			X		Material C.P.R.	8	1	9 5/16 X 27 1/8	
Material			X		Material F.C. B.B.	8	1	9 5/16 X 14 1/2	
Material			X		Material			X	
F.C. Board		100	1		B.C. Board			X	
B.C. Board		100	1		B.B. Board	100	1	8 3/32 X 31 1/32	
Center Board		100	2		Board	100	1	9 X 1	
Board			X		Strip			X	
Cover Pad			X		Strip			X	
					B.B. Pad			X	

Product Code

Style Case

VRB

LOC-SH

Sheet Size

8 1/2 x 7 1/2

Cap. Z

Die No. 4662

Order No.

967837

Plate C-11-2

Customer

DATA TRANSLATION

Metal	
Total Vinyl	
Quantity	200
Date	2-14-91
Type Corners	
Radius	3/8
Completed	

	Gauge	Thick
Tear Seal	1014	1/16"
Bar Seal	UB-L1	5/32"
Bar Seal		

	No. of Feet
Tear Seal	
Bar Seal	
Bar Seal	

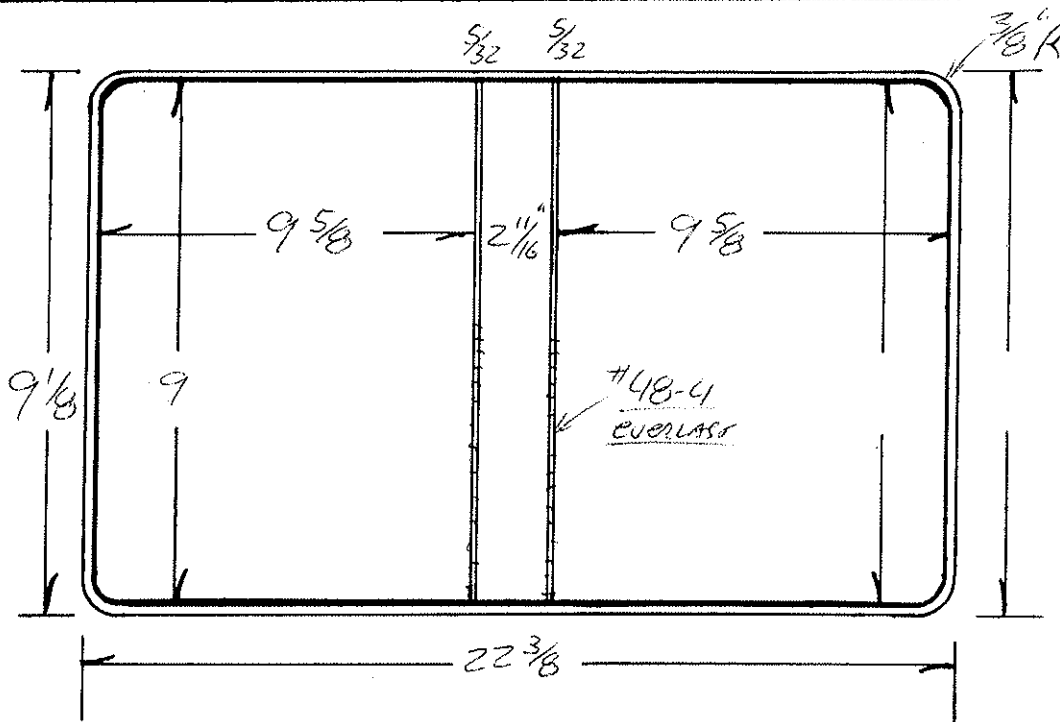

SIZE - B. Pass
CHECK. *[Signature]*

Code	Ga.	PCS	Cutting Specs		Code	Ga.	Pcs.	Cutting Specs.	
			Size	Out				Size	Out
Cover Mat.			9 3/4	23 1/8	Lining Mat.			9 3/4	23 1/8
Cover Mat.				X	Lining Mat.				X
Vert. Pckt.				X	Horz. Pckt.			5 7/8	23 1/8
Vert. Pckt.				X	Horz. Pckt.				X
Pocket				X	Pocket				X
Label Holder	FULL			X	Card Holder				X
Material	C.O.L.		9 1/4	23 1/8	Material				X
Material				X	Material				X
Material				X	Material				X
F.C. Board			8 29/32	9 17/32	B.C. Board				X
B.G. Board			8 29/32	9 17/32	B.B. Board			8 29/32	2 19/32
Center Board			8 15/16	9 9/16	Board			8 15/16	2 19/32
Board				X	Strip				X
Cover Pad				X	Strip				X
					B.B. Pad				X

Product Code

Style Case VRB LOC

Sheet Size 8 1/2 X 7

Cap. 1 1/2

Die No. 4845

Order No. 969710

Plate C-17-9

Customer

GOODWAY GRAPHICS

8-16

Metal
Total Vinyl
Quantity <u>1,000</u>
Date <u>8-1-91</u>
Type Corners
Radius
Completed

	Gauge	Thick
Tear Seal	<u>.014</u>	<u>1/16</u>
Bar Seal	<u>#25-4</u>	<u>5/32</u>
Bar Seal		

	No. of Feet
Tear Seal	
Bar Seal	
Bar Seal	

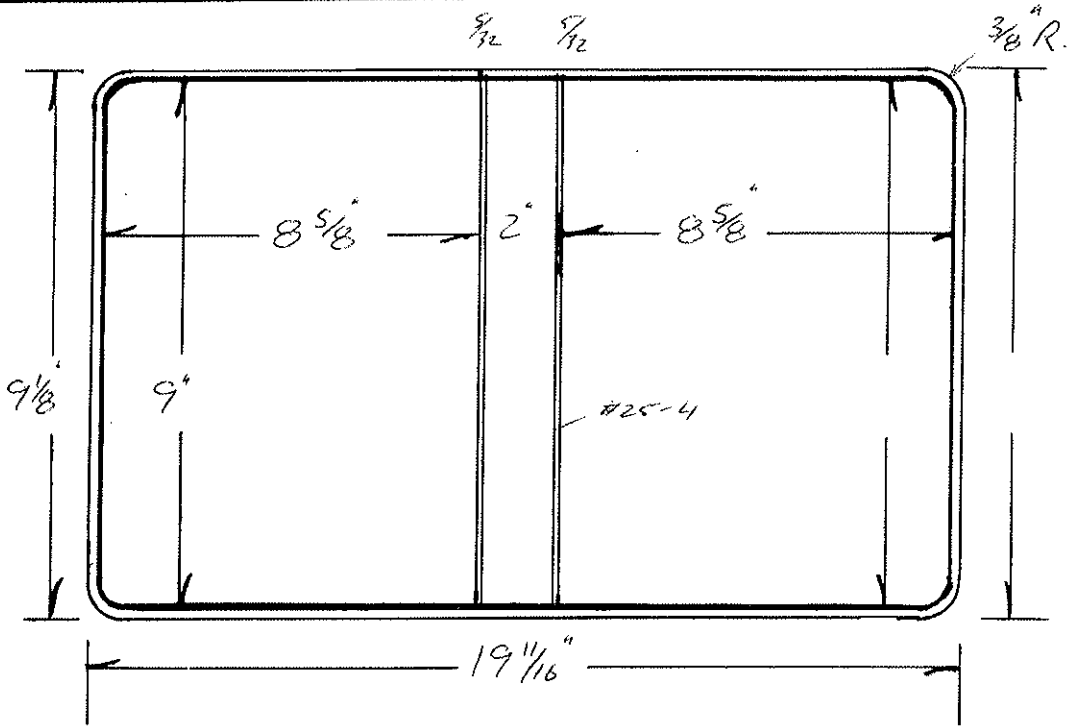

OWB - Blue
Check [Signature]

Code		Ga.	# PCS	Size	Out	Cutting Specs	Code		Ga.	# Pcs.	Size	Out	Cutting Specs
Cover Mat.	$9 \frac{3}{4} \times 20 \frac{1}{2}$	14	1				Lining Mat.	$9 \frac{3}{4} \times 20 \frac{1}{2}$	14	1			
Cover Mat	X						Lining Mat.	X					
Vert. Pckt.	X						Horz. Pckt.	X					
Vert. Pckt.	X						Horz. Pckt.	X					
Pocket	X						Pocket	X					
Label Holder	$3 \frac{1}{8} \times 2 \frac{5}{16}$	8	1				Card Holder	X					
Material	X						Material	X					
Material	X						Material	X					
Material	X						Material	X					
F.C. Board	$8 \frac{29}{32} \times 8 \frac{17}{32}$	100	1				B.C. Board	$8 \frac{15}{16} \times 1 \frac{29}{32}$	100				
B.C. Board	$8 \frac{29}{32} \times 8 \frac{17}{32}$	100	1				B.B. Board	$8 \frac{29}{32} \times 1 \frac{29}{32}$	100	1			
Center Board	$8 \frac{15}{16} \times 8 \frac{9}{16}$	100	2				Board	$8 \frac{7}{8} \times 1 \frac{7}{16}$	22	1			
Board	X						Strip	X					
Cover Pad	X						Strip	X					
							B.B. Pad	X					

Product Code

Style Case *VRB 8 1/2-3-1 1/4*

Sheet Size *8 1/2 X 5 3/4* Cap. *1 1/4*

Die No. *4848*

Order No. *969627*

Plate *C-18-1*

Customer

CURRY PRINTING

8-23

Metal
Total Vinyl
Quantity <i>250</i>
Date <i>8-6-91</i>
Type Corners
Radius <i>3/8</i>
Completed

	Gauge	Thick
Tear Seal	<i>.014</i>	<i>1/16</i>
Bar Seal	<i>#48-4</i>	<i>3/16</i>
Bar Seal		

	No. of Feet
Tear Seal	
Bar Seal	
Bar Seal	

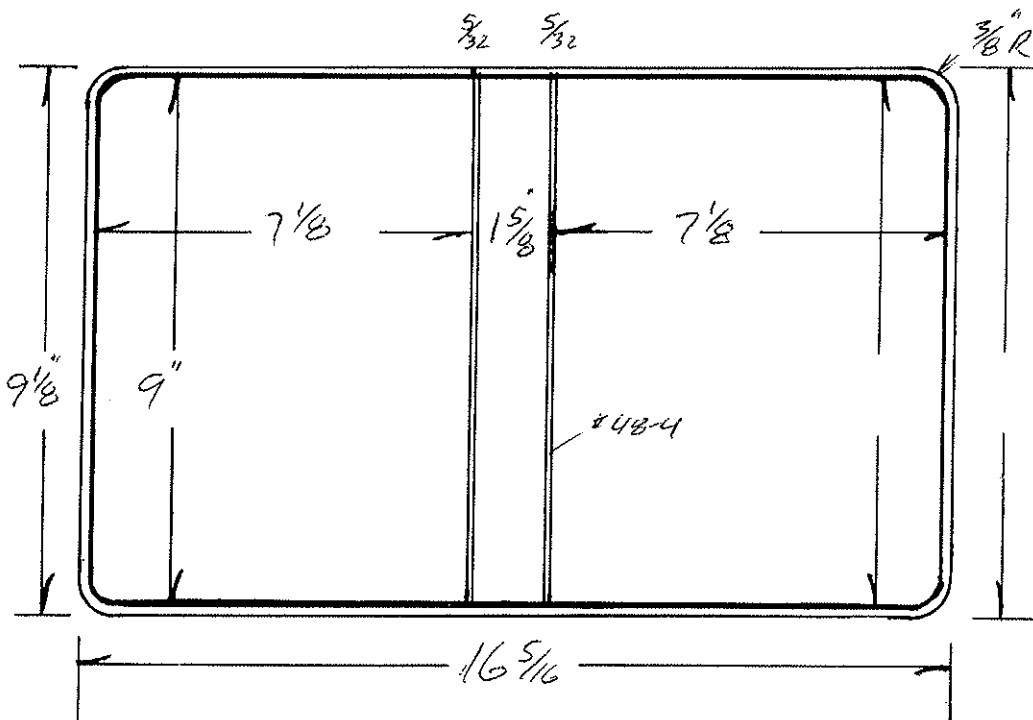

Dwg - Biller
check
PAW

Code	Ga.	# PCS	Cutting Specs		Code	Ga.	# Pcs.	Cutting Specs	
			Size	Out				Size	Out
Cover Mat.	<i>9 3/4</i>	<i>14</i>	<i>1</i>		Lining Mat.	<i>9 3/4</i>	<i>14</i>	<i>1</i>	
Cover Mat.					Lining Mat.				
Vert. Pckt.					Horz. Pckt.				
Vert. Pckt.					Horz. Pckt.				
Pocket					Pocket				
Label Holder					Card Holder		<i>8</i>	<i>1</i>	
Material					Material				
Material					Material				
Material					Material				
F.C. Board	<i>8 29/32</i>	<i>100</i>	<i>1</i>		B.C. Board				
B.C. Board	<i>8 29/32</i>	<i>100</i>	<i>1</i>		B.B. Board	<i>8 29/32</i>	<i>100</i>	<i>1</i>	
Center Board					Board				
Board					Strip				
Cover Pad					Strip				
					B.B. Pad				

Product Code

Style Case VRR

Sheet Size 8 1/2 x 11 1/2 Cap. 1 1/2

Die No. 4950

Order No. 970966

Plate 0-3-1

Customer

GRAFALON

1-21

Metal
Total Vinyl
Quantity 3300
Date 12-31-91
Type Corners
Radius 3/4
Completed

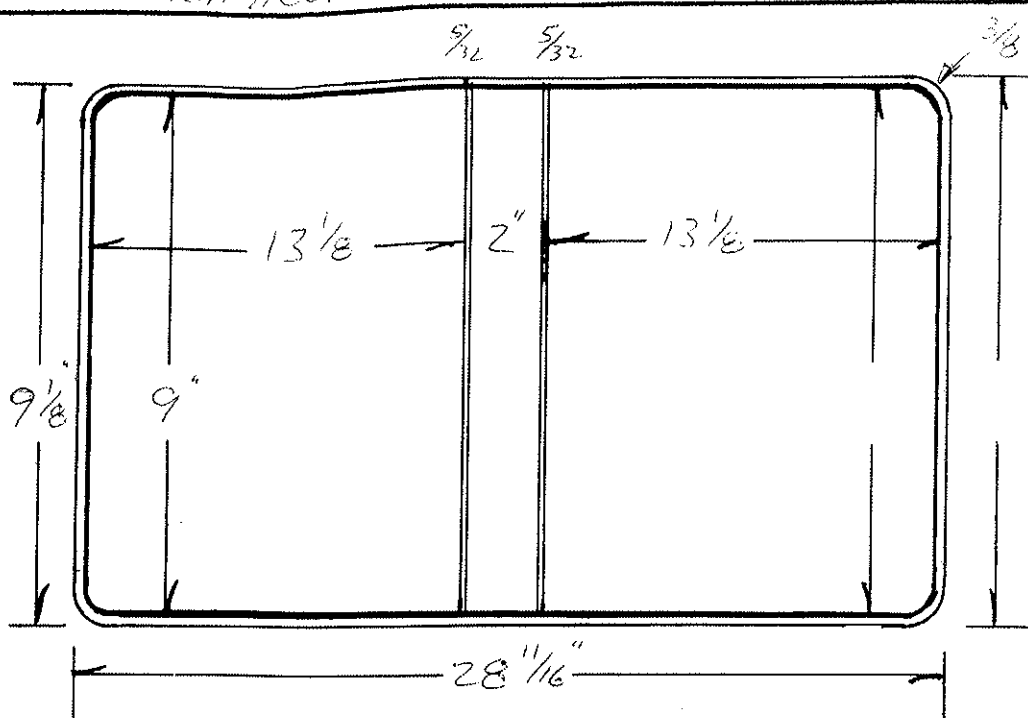

	Gauge	Thick
Tear Seal		
Bar Seal		
Bar Seal		

	No. of Feet
Tear Seal	
Bar Seal	
Bar Seal	

DWG B. PAGE
 CHECK (JPD)

Code	Ga.	#	PCS	Cutting Specs		Code	Ga.	#	PCS	Cutting Specs			
				Size	Out					Size	Out		
Cover Mat.			1	9 3/4	29 3/4	Lining Mat.			1	9 3/4	29 3/4		
Cover Mat					X	Lining Mat.					X		
Vert. Pckt.					X	Horz. Pckt.					X		
Vert. Pckt.					X	Horz. Pckt.					X		
Pocket					X	Pocket					X		
Label Holder	VERT.				X	Card Holder					X		
Material	CAL.		8	1	9 3/4	13 7/16	Material				X		
Material					X	Material					X		
Material					X	Material					X		
F.C. Board			100	1	8 15/16	13 1/16	B.C. Board				X		
B.C. Board			100	1	8 15/16	13 1/16	B.B. Board			8 15/16	1 29/32	100	1
Center Board					X	Board					X		
Board					X	Strip					X		
Cover Pad					X	Strip					X		
						B.B. Pad					X		

Product Code

Style Case

VRB

Sheet Size

8 1/2 X 14 1/2 Cap. 1 1/2

Die No. 5030

Order No.

971773

Plate

K-5-4

Customer

CITY OF VISALIA

4-13

Metal
Total Vinyl
Quantity 100
Date 3-25-92
Type Corners
Radius 3/8"
Completed

	Gauge	Thick
Tear Seal	.012	1/16
Bar Seal	48-4	5/32
Bar Seal		

	No. of Feet
Tear Seal	
Bar Seal	
Bar Seal	

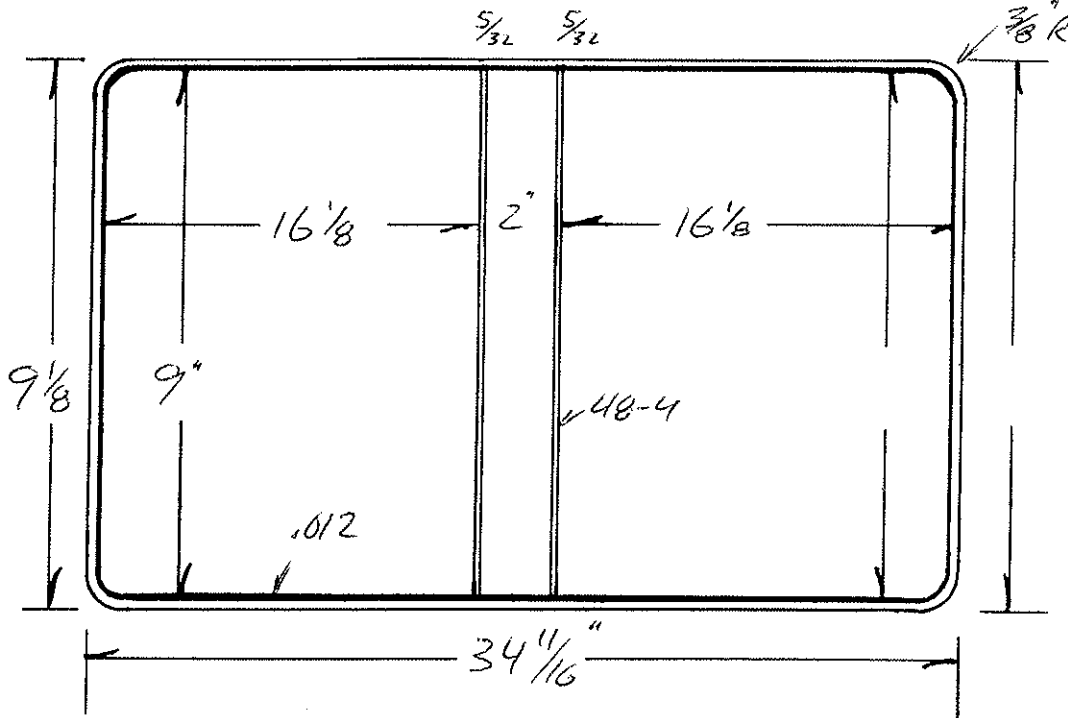

DWGS - B. Price
 CHECK. *[Signature]*

		Cutting Specs						Cutting Specs					
Code (5-out)		Ga.	#	PCS	Size	Out	Code (5-out)		Ga.	#	PCS	Size	Out
Cover Mat.	9 3/4 X 35 1/2	12		1			Lining Mat.	9 3/4 X 35 1/2	12		1		
Cover Mat.	X						Lining Mat.	X					
Vert. Pckt.	X						Horz. Pckt.	X					
Vert. Pckt.	X						Horz. Pckt.	X					
Pocket	X						Pocket	X					
Label Holder	X						Card Holder	X					
Material	X						Material	X					
Material	X						Material	X					
Material	X						Material	X					
F.C. Board	8 15/16 X 16 1/16	100		1			B.C. Board	X					
B.C. Board	8 15/16 X 16 1/16	100		1			B.B. Board	8 15/16 X 12 9/32	100		1		
Center Board	X						Board	X					
Board	X						Strip	X					
Cover Pad	X						Strip	X					
							B.B. Pad	X					

DIE #	6239	METAL	3" SCREWPOST	RADIUS	1/4"
ORDER #	987098	CUSTOMER	ADO CORP.	TEAR SEAL	.014
SHEET SIZE	OA 8.5 X 8.5	STYLE CASE	VINYL BINDER / HANDLE	BAR SEAL	253-102
CAP.	3"	DUE DATE	5-8-97	COMPLETED	
LOCATION	H-4-9	QUANTITY	2	DATE	4-30-97

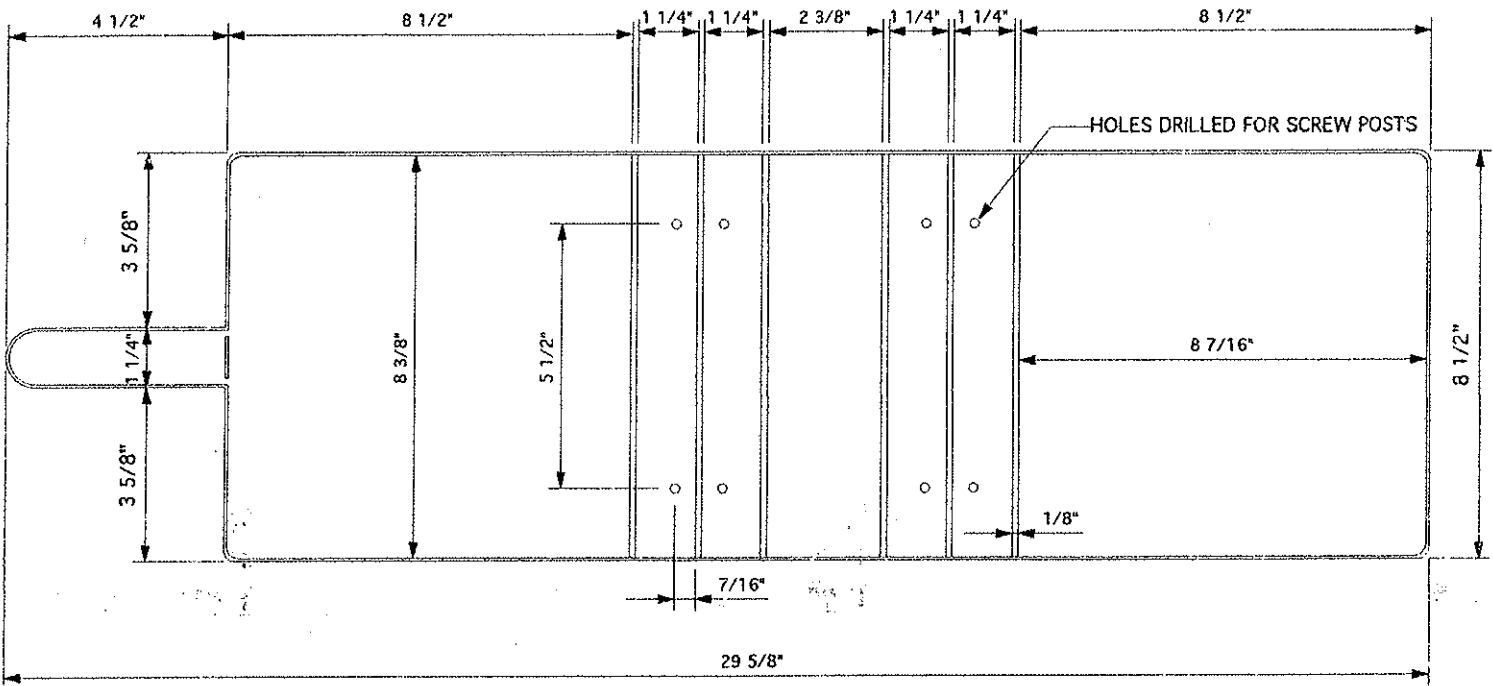

BINDER HAS SNAP LOCK ON STRAP.

MATERIAL SPECS		GAUGE		MATERIAL SPECS		GAUGE	
COVER MAT.	9 1/4 X 30 3/8		1	LINING MAT.	9 1/4 X 30 3/8		1
COVER MAT.				LINING MAT.			
DIE CUT				HORZ. PKT.	9 1/4 X 11		1
COL	9 1/4 X 8 3/4		1	HORZ. PKT.	9 1/4 X 7 3/8		1
LABEL HOLDER				DIE CUT			
GUSSET				REINF.			
BOARD SPECS		GAUGE		BOARD SPECS		GAUGE	
F.C. BOARD	8 5/16 X 8 3/8	120	1	F.C. BOARD			
B.B. BOARD	8 5/16 X 2 9/32	120	1	B.B. BOARD			
B.C. BOARD	8 5/16 X 8 3/8	120	1	B.C. BOARD			
FLAP BD.				DIE CUT			
BOARD	8 5/16 X 1 5/32	100	4	DIE CUT			

DIE #	6249	METAL	LOC	RADIUS	3/8"
ORDER #	987235	CUSTOMER	BECKY WYATT	TEAR SEAL	.014
SHEET SIZE	8 1/2 X 14 1/2	STYLE CASE	VINYL RING BINDER	BAR SEAL	253
CAP.	1"	DUE DATE	5-23-97	COMPLETED	
LOCATION	M-1-1	QUANTITY	2	DATE	5-20-9

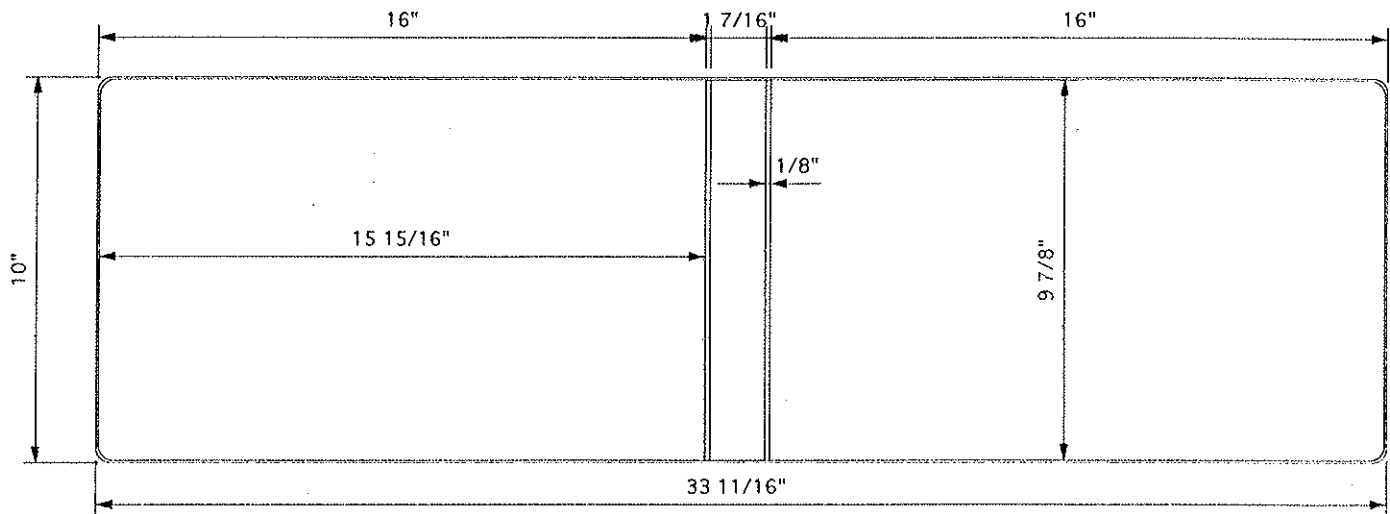

MATERIAL SPECS		GAUGE PCS.		MATERIAL SPECS		GAUGE	
COVER MAT.	11 X 34 11/16		1	LINING MAT.	10 3/4 X 34 1/2		
COVER MAT.				LINING MAT.			
DIE CUT				HORZ. PKT.			
COL				VERT. PKT.			
LABEL HOLDER				DIE CUT			
GUSSET				REINF.			
BOARD SPECS		GAUGE PCS.		BOARD SPECS		GAUGE	
F.C. BOARD	9 25/32 X 15 27/32	120	1	F.C. BOARD			
B.B. BOARD	9 25/32 X 1 11/32	120	1	B.B. BOARD			
B.C. BOARD	9 25/32 X 15 27/32	120	1	B.C. BOARD			
FLAP BD.				DIE CUT			
BOARD				DIE CUT			

DIE #	6270	METAL	LOC	RADIUS	3/8"
ORDER #	75891	CUSTOMER	FEDERAL EXPRESS	TEAR SEAL	.014
SHEET SIZE	8.5 X 8	STYLE CASE	VINYL RING BINDER	BAR SEAL	253
CAP.	1"	DUE DATE	6-24-97	COMPLETED	
LOCATION	H-3-1	QUANTITY	1	DATE	6-18-9

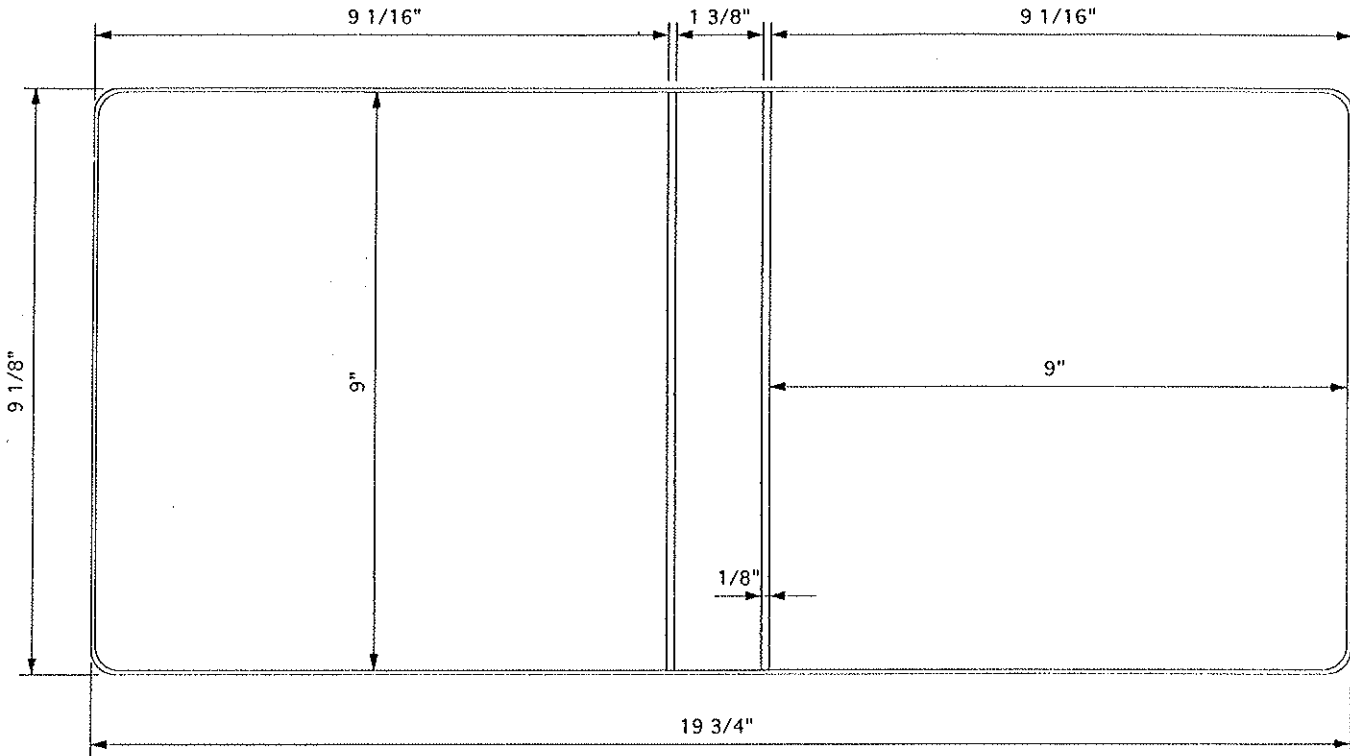

MATERIAL SPECS		GAUGE		PCS.		MATERIAL SPECS		GAUGE	
COVER MAT.	9 7/8 X 20 1/2			1		LINING MAT.	9 7/8 X 20 1/2		
COVER MAT.						LINING MAT.			
DIE CUT						HORZ. PKT.	4 7/8 X 9 1/2		
COL						VERT. PKT.			
LABEL HOLDER						DIE CUT			
GUSSET						REINF.			
BOARD SPECS		GAUGE		PCS.		BOARD SPECS		GAUGE	
F.C. BOARD	8 15/16 X 8 15/16	100		1		F.C. BOARD			
B.B. BOARD	8 15/16 X 1 9/32	100		1		B.B. BOARD			
B.C. BOARD	8 15/16 X 8 15/16	100		1		B.C. BOARD			
FLAP BD.						DIE CUT			
BOARD						DIE CUT			

DIE #	6670	METAL	ANGLE D	RADIUS	3/8"
ORDER #	220214	CUSTOMER	SOUTHTREND	TEAR SEAL	.012
SHEET SIZE	8.5 X 11.5	STYLE CASE	VINYL RING BINDER	BAR SEAL	254
CAP.	3"	DUE DATE	4-5-99	COMPLETED	
LOCATION	I-11-3	QUANTITY	25	DATE	3-18-99

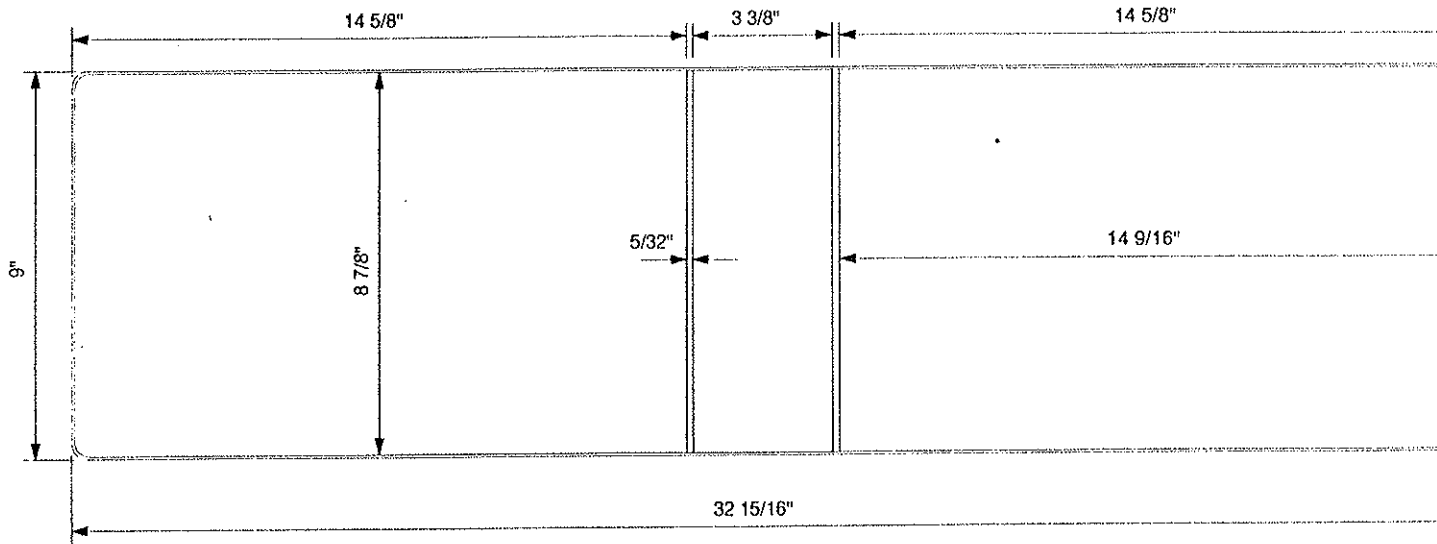

MATERIAL SPECS		GAUGE	PCS.	MATERIAL SPECS		GAUGE	P.
COVER MAT.	9 3/4 X 33 3/4		1	LINING MAT.	9 3/4 X 33 3/4		
COVER MAT.				LINING MAT.			
DIE CUT				HORZ. PKT.			
COL				VERT. PKT.			
LABEL HOLDER				DIE CUT			
GUSSET				REINF.			
BOARD SPECS		5/16" R. CORNERS		GAUGE	PCS.	BOARD SPECS	
F.C. BOARD	8 13/16 X 14 1/2	120	1	F.C. BOARD			
B.B. BOARD	8 13/16 X 3 9/32	120	1	B.B. BOARD			
B.C. BOARD	8 13/16 X 14 1/2	120	1	B.C. BOARD			
FLAP BD.				DIE CUT			
BOARD				DIE CUT			

DIE #	6682-R	METAL	8.5 - LOC	RADIUS	3/8"
ORDER #		CUSTOMER	AMERICAN GENERAL	TEAR SEAL	.014
SHEET SIZE	8 1/2 x 7	STYLE CASE	VINYL BINDER	BAR SEAL	253
CAP.	1"	DUE DATE	4-20-99	COMPLETED	
LOCATION	1-12-4	QUANTITY	1	DATE	4-19-99

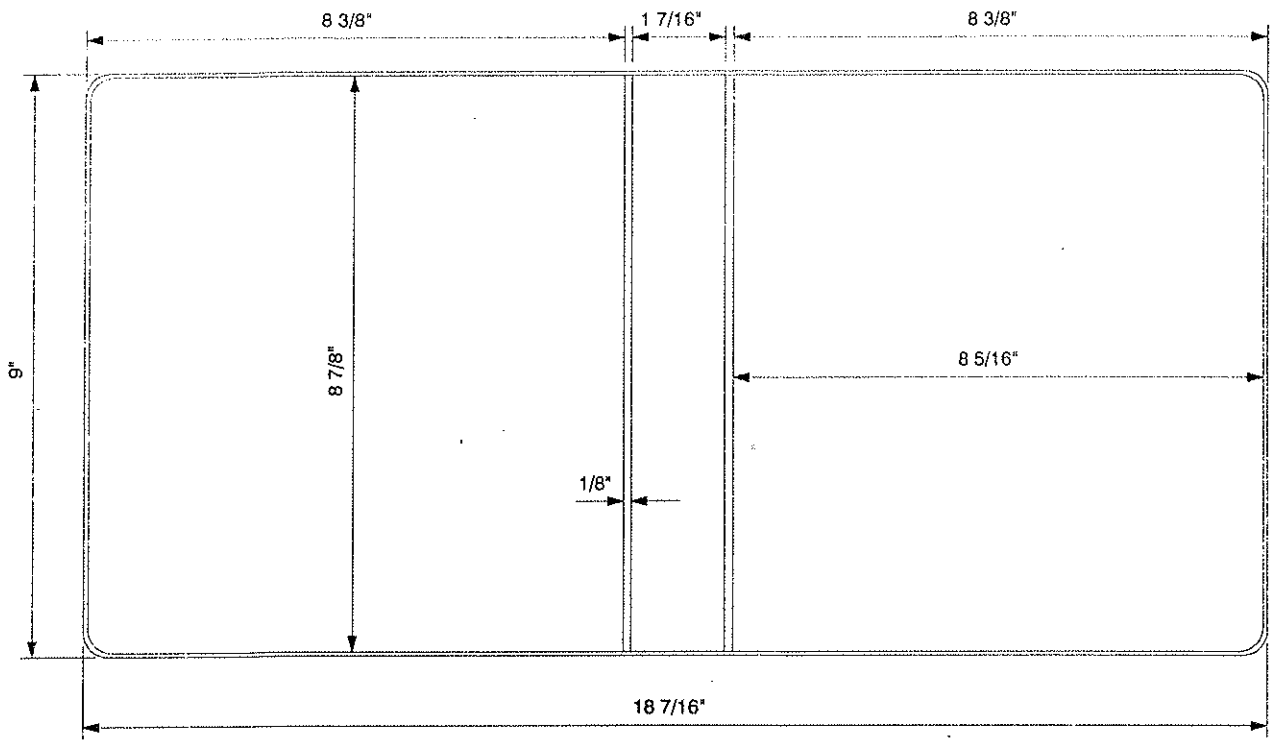

MATERIAL SPECS		GAUGE	PCS.	MATERIAL SPECS		GAUGE	PCS.
COVER MAT.	10 X 19 1/2		1	LINING MAT.	9 3/4 X 19 1/4		1
COVER MAT.				LINING MAT.			
DIE CUT				HORZ. PKT.	8 3/8 X 8 7/8		1
COL				HORZ. PKT.	4 3/8 X 8 7/8		1
LABEL HOLDER				PEN LOOP			
GUSSET				REINF.			

BOARD SPECS		5/16" R. CORNERS		GAUGE	PCS.	BOARD SPECS		5/16" R. CORNERS		GAUGE	PCS.
F.C. BOARD	8 25/32 X 8 7/32	100	1	F.C. BOARD							
B.B. BOARD	8 25/32 X 1 11/32	100	1	B.B. BOARD							
B.C. BOARD	8 25/32 X 8 7/32	100	1	B.C. BOARD							
FLAP BD.	PADDED			DIE CUT							
BOARD				DIE CUT							

DIE #	7201	METAL	RR OR STR D	RADIUS	3/8"
ORDER #	472024	CUSTOMER	EBSCO MEDIA	TEAR SEAL	.010
SHEET SIZE	8 1/2 X 4 1/4	STYLE CASE	VINYL BINDER	BAR SEAL	48-3
CAP.	1"	DUE DATE	1-10-02	COMPLETED	
LOCATION		QUANTITY	500	DATE	1-6-02

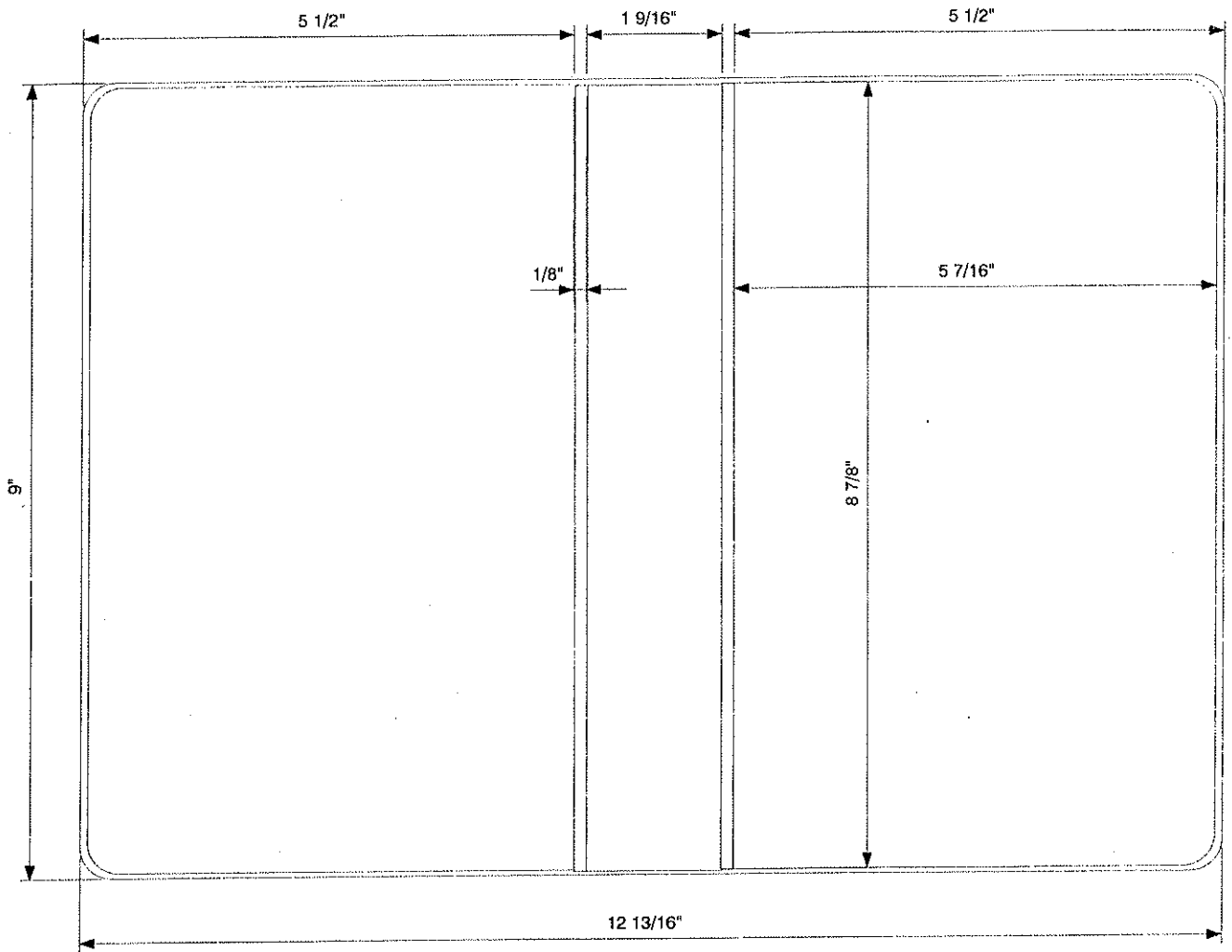

MATERIAL SPECS		GAUGE	PCS.	MATERIAL SPECS		GAUGE	PCS.
COVER MAT.	9 3/4 X 13 1/2		1	LINING MAT.	9 3/4 X 13 1/2		1
COVER MAT.				LINING MAT.			
DIE CUT				HORZ. PKT.	4 3/8 X 6		1
COL Ex	9/18 x 7 15/16 No tin			VERT. PKT.			
LABEL HOLDER				DIE CUT			
GUSSET				REINF.			

BOARD SPECS		GAUGE	PCS.	BOARD SPECS		GAUGE	PCS.
	5/16" R. CORNERS				5/16" R. CORNERS		
F.C. BOARD	8 13/16 X 5 3/8	100	1	F.C. BOARD			
B.B. BOARD	8 13/16 X 1 15/32	100	1	B.B. BOARD			
B.C. BOARD	8 13/16 X 5 3/8	100	1	B.C. BOARD			
FLAP BD.				DIE CUT			
BOARD				DIE CUT			

DIE #	7420	METAL	ANGLE D	RADIUS	3/8"
ORDER #	550299	CUSTOMER	UNIVERSITY OF MISSOURI	TEAR SEAL	.012
SHEET SIZE	8 1/2 X 14 1/2	STYLE CASE	VRB	BAR SEAL	48-4
CAP.	1"	DUE DATE	4-30-03	COMPLETED	
LOCATION		QUANTITY	100	DATE	4-10-03

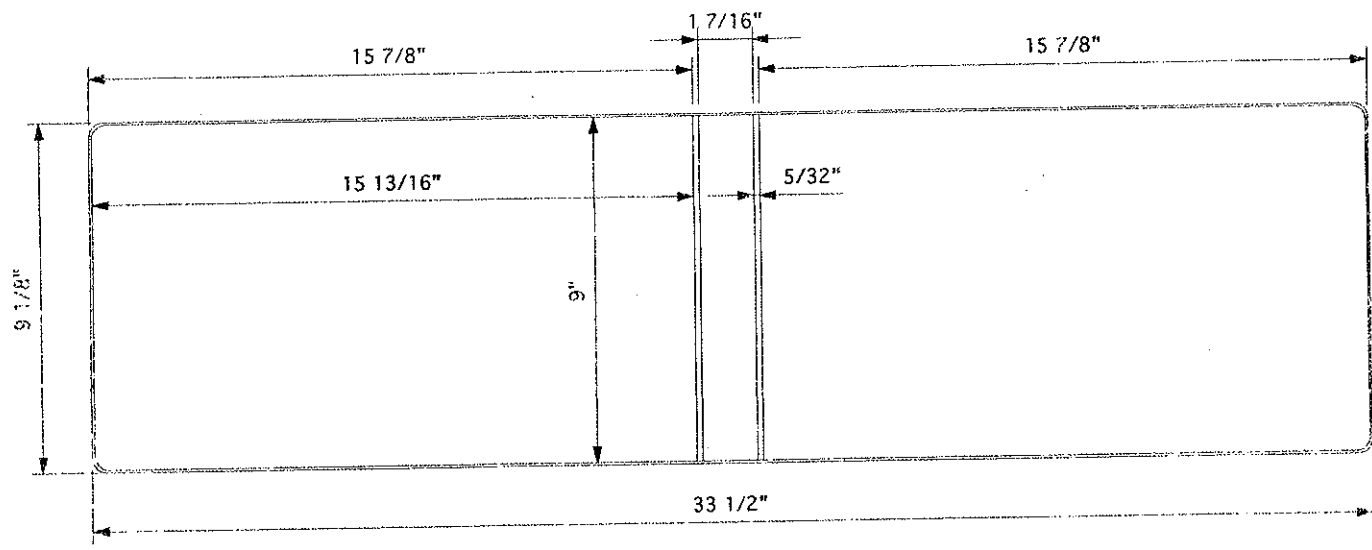

MATERIAL SPECS		GAUGE	PCS.	MATERIAL SPECS		GAUGE	PCS.
COVER MAT.	9 7/8 X 34 1/2		1	LINING MAT.	9 7/8 X 34 1/2		1
COVER MAT.				LINING MAT.			
DIE CUT	6905-DE 9 7/8 x 33		1	HORZ. PKT.			
COL -EX	9 1/4 X 18 /12		1	VERT. PKT.			
LABEL HOLDER				DIE CUT			
GUSSET				REINF.			
BOARD SPECS	5/16" X CORNERS	GAUGE	PCS.	BOARD SPECS	5/16" R. CORNERS	GAUGE	PCS.
F.C. BOARD	8 15/16 X 15 3/4	120	1	F.C. BOARD			
B.B. BOARD	8 15/16 X 1 11/32	120	1	B.B. BOARD			
B.C. BOARD	8 15/16 X 15 3/4	120	1	B.C. BOARD			
FLAP BD.				DIE CUT			
BOARD				DIE CUT			

DIE #	7782	METAL	ROUND RING	RADIUS	3/8"
ORDER #	648149	CUSTOMER	MRS A'S CORPORTION	TEAR SEAL	.014
SHEET SIZE	8 1/2 X 7 1/2	STYLE CASE	VINYL BINDER	BAR SEAL	253
CAP.	1 1/4"	DUE DATE	11-30-04	COMPLETED	
LOCATION		QUANTITY	5000	DATE	10-29-04

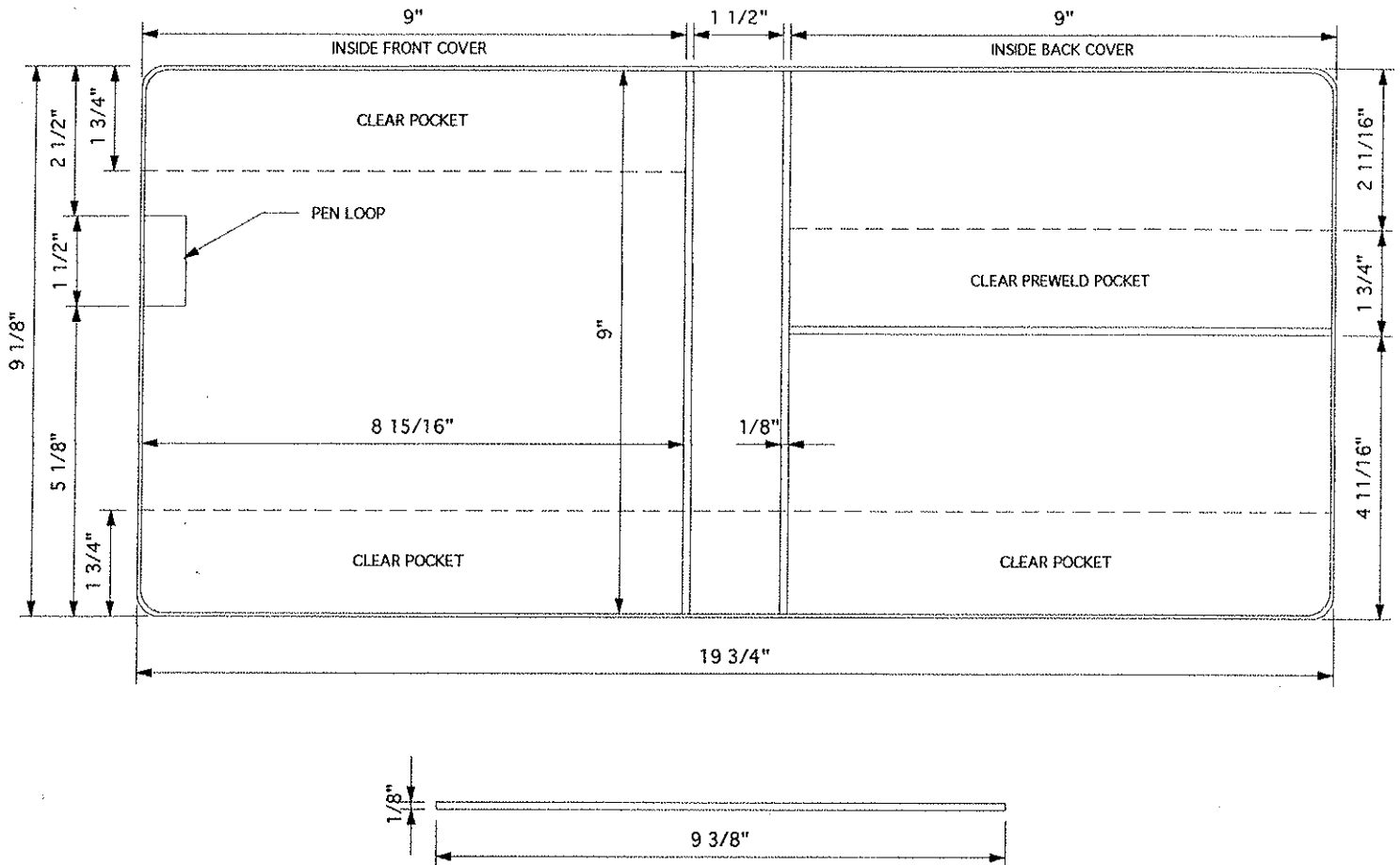

MATERIAL SPECS		GAUGE	PCS.	MATERIAL SPECS		GAUGE	PCS.
COVER MAT.	9 7/8 X 20 1/2	WHITE	1	LINING MAT.	9 7/8 X 20 1/2	WHITE	1
COVER MAT.				LINING MAT.			
DIE CUT				HORZ. PKT.	2 1/8 X 20 1/2	CLEAR	1
COL				HORZ. PKT.	2 1/8 X 9 1/2	CLEAR	1
PEN LOOP	1 1/2 X 2	WHITE	1	HORZ. PKT.	1 3/4 X 9 1/2	CLEAR	1
GUSSET				REINF.			
BOARD SPECS		GAUGE	PCS.	BOARD SPECS		GAUGE	PCS.
F.C. BOARD	8 15/16 X 8 7/8	100	1	F.C. BOARD	5/16" R. CORNERS		
B.B. BOARD	8 15/16 X 1 13/32	100	1	B.B. BOARD			
B.C. BOARD	8 15/16 X 8 7/8	100	1	B.C. BOARD			
FLAP BD.				DIE CUT			
BOARD				DIE CUT			

DIE #	8094	METAL	RR	RADIUS	3/8"
ORDER #	725255	CUSTOMER	MOORE WALLACE	TEAR SEAL	.012
SHEET SIZE	8 1/2 X 11 1/2	STYLE CASE	VINYL BINDER	BAR SEAL	48-4
CAP.	2"	DUE DATE	3-28-06	COMPLETED	
LOCATION		QUANTITY	175	DATE	3-20-06

*** WARNING DRAWING NOT ACTUAL SIZE ***

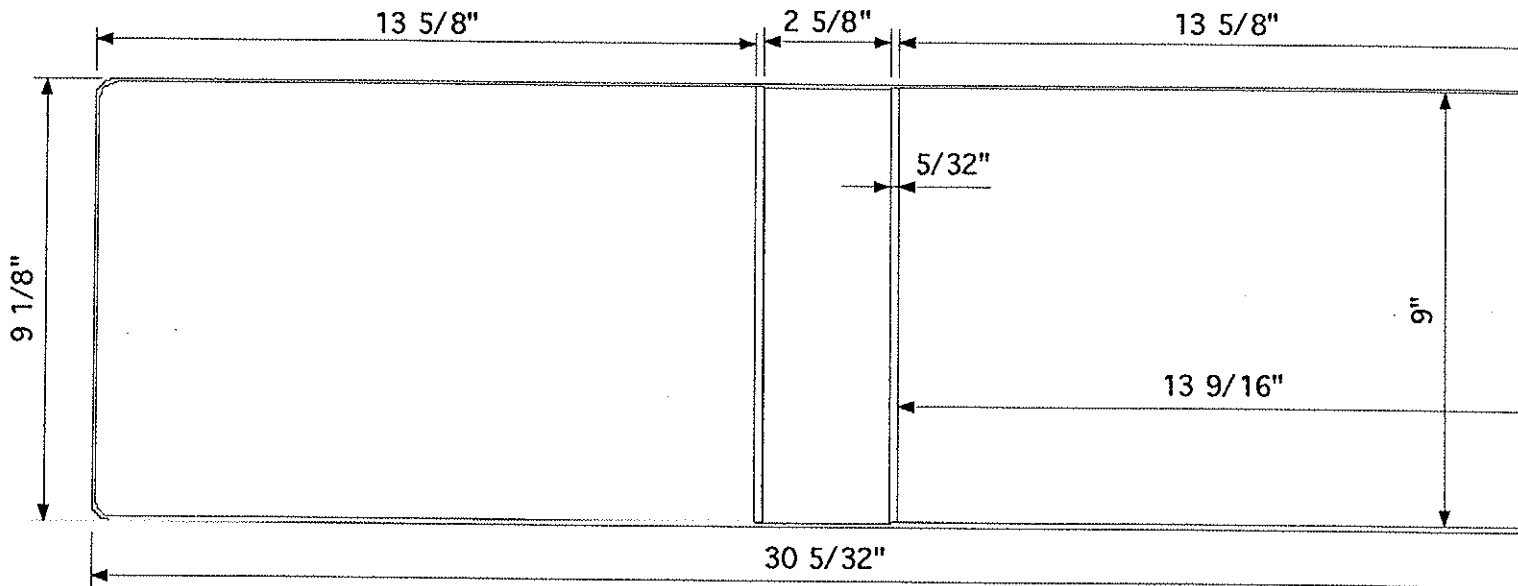

MATERIAL SPECS		GAUGE	PCS.	MATERIAL SPECS		GAUGE	PCS.
COVER MAT.	9 7/8 X 30 7/8		1	LINING MAT.	9 7/8 X 30 7/8		1
COVER MAT.				LINING MAT.			
DIE CUT				HORZ. PKT.			
COL				VERT. PKT.			
LABEL HOLDER				DIE CUT			
GUSSET				REINF.			
BOARD SPECS		5/16" R. CORNERS		GAUGE	PCS.	BOARD SPECS	
F.C. BOARD	8 15/16 X 13 1/2	120	1	F.C. BOARD			
B.B. BOARD	8 15/16 X 2 17/32	120	1	B.B. BOARD			
B.C. BOARD	8 15/16 X 13 1/2	120	1	B.C. BOARD			
FLAP BD.				DIE CUT			
BOARD				DIE CUT			