

Product Code

Style Case *Ring Binder*

Sheet Size 9 X 12 Cap. 1 1/4 Die No. 3920 Order No. 957076 Plate

Customer

Donald J. Haggerty

Metal
Total Vinyl <i>.030</i>
Quantity <i>100</i>
Date <i>12-22-87</i>
Type Corners <i>Rd.</i>
Radius <i>1/4</i>
Completed

	Gauge	Thick
Tear Seal	<i>.016</i>	<i>3/32</i>
Bar Seal	<i>253</i>	<i>1/8</i>
Bar Seal		

	No. of Feet
Tear Seal	
Bar Seal	
Bar Seal	

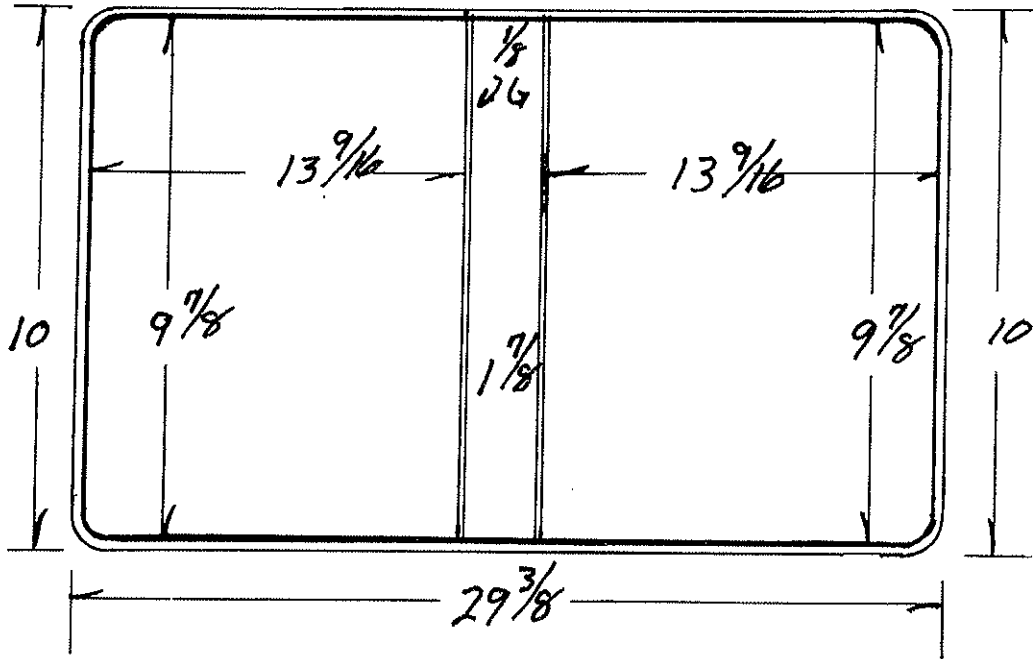

Code				Cutting Specs				Code				Cutting Specs			
				Ga.	# PCS	Size	Out					Ga.	# Pcs.	Size	Out
Cover Mat.	<i>Padded</i>	<i>11</i>	X		<i>1</i>	<i>30 3/8</i>		Lining Mat.	<i>Padded</i>	<i>11</i>	X		<i>1</i>	<i>30 3/8</i>	
Cover Mat.			X					Lining Mat.			X				
Vert. Pckt.			X					Horz. Pckt.		<i>5 1/2</i>	X	<i>14 1/4</i>		<i>1</i>	
Vert. Pckt.			X					Horz. Pckt.			X				
Pocket			X					Pocket			X				
Label Holder			X					Card Holder			X				
Material			X					Material			X				
Material			X					Material			X				
Material			X					Material			X				
F.C. Board		<i>9 13/16</i>	X		<i>1</i>	<i>13 1/2</i>		B.C. Board		<i>9 13/16</i>	X	<i>13 1/2</i>		<i>1</i>	
B.C. Board			X					B.B. Board		<i>9 13/16</i>	X	<i>1 13/16</i>		<i>1</i>	
Center Board			X					Board			X				
Board			X					Strip			X				
Cover Pad			X					Strip			X				
								B.B. Pad			X				

Product Code

Style Case *U.S. King Ring Binder angle D*

Sheet Size *9 1/2 x 6 1/4* Cap. *1 1/2* Die No. *3950* Order No. *957845* Plate

Customer *Bell South Services*

Metal
Total Vinyl .030
Quantity 25
Date
Type Corners <i>RD</i>
Radius <i>1/4</i>
Completed

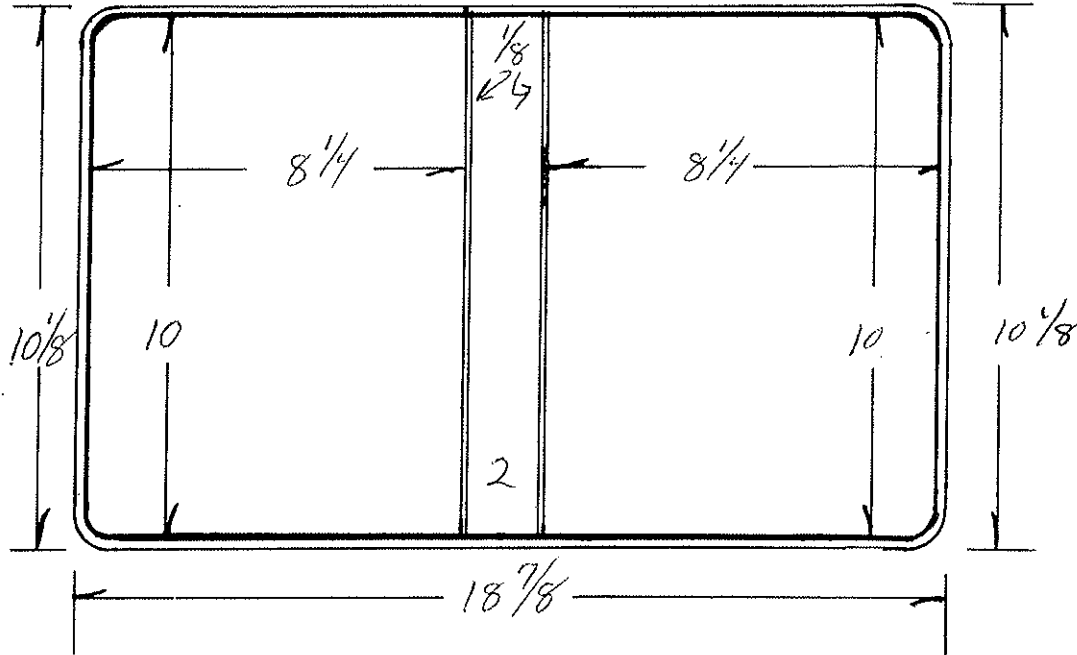

	Gauge	Thick
Tear Seal	.016	<i>3/32</i>
Bar Seal	2.53	<i>1/8</i>
Bar Seal		

	No. of Feet
Tear Seal	
Bar Seal	
Bar Seal	

Code	Ga.	#	PCS	Cutting Specs.		Code	Ga.	#	PCS	Cutting Specs.	
				Size	Out					Size	Out
Cover Mat.			1	<i>10 3/4</i>	<i>19 1/2</i>	Lining Mat.			1	<i>10 3/4</i>	<i>19 1/2</i>
Cover Mat.				X		Lining Mat.				X	
Vert. Pckt.				X		Horz. Pckt.				X	
Vert. Pckt.				X		Horz. Pckt.				X	
Pocket				X		Pocket			1	<i>10 1/16</i>	<i>11 3/8</i>
Label Holder				X		Card Holder				X	
Material				X		Material				X	
Material				X		Material				X	
Material				X		Material				X	
F.C. Board			1	<i>9 29/32</i>	<i>8 5/32</i>	B.C. Board			1	<i>9 29/32</i>	<i>8 5/32</i>
B.C. Board				X		B.B. Board			1	<i>9 29/32</i>	<i>1 29/32</i>
Center Board				X		Board				X	
Board				X		Strip				X	
Cover Pad				X		Strip				X	
						B.B. Pad				X	

Product Code

Style Case VRB

Sheet Size 9 1/2 X 6 3/4 Cap. 2

Die No. 3977

Order No. 958243

Plate

Customer Weaver Paper Co.

Metal
Total Vinyl
Quantity <u>2500</u>
Date
Type Corners <u>Rd</u>
Radius <u>1/4</u>
Completed

	Gauge	Thick
Tear Seal	<u>16</u>	<u>3/32</u>
Bar Seal	<u>178</u>	<u>3/16</u>
Bar Seal		

	No. of Feet
Tear Seal	
Bar Seal	
Bar Seal	

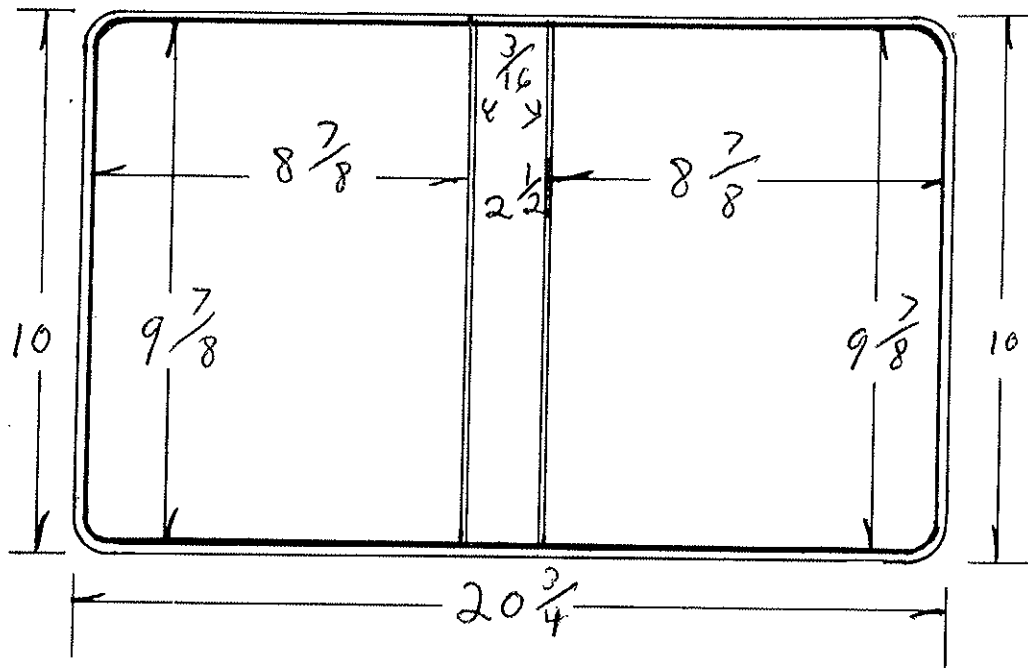

Code		Cutting Specs		Code		Cutting Specs			
		Ga.	# PCS	Size	Out	Ga.	# Pcs.	Size	Out
Cover Mat.	<u>10 5/8 X 21 3/8</u>		<u>1</u>			Lining Mat.	<u>10 5/8 X 21 3/8</u>		<u>1</u>
Cover Mat	X					Lining Mat.	X		
Vert. Pckt.	X					Horz. Pckt.	X		
Vert. Pckt.	X					Horz. Pckt.	X		
Pocket	X					Pocket	X		
Label Holder	X					Card holder	X		
Material	X					Material	X		
Material	X					Material	X		
Material	X					Material	X		
F.C. Board	<u>9 25/32 X 8 25/32</u>		<u>1</u>			B.C. Board	<u>9 25/32 X 8 25/32</u>		<u>1</u>
B.C. Board	X					B.B. Board	<u>9 25/32 X 2 13/32</u>		<u>1</u>
Center Board	X					Board	X		
Board	X					Strip	X		
Cover Pad	X					Strip	X		
						B.B. Pad	X		

Product Code

Style Case V RB Ribbed hinge

Sheet Size 9 x 7 1/2 Cap. 1

Die No. 3984 Order No. 958407 Plate

Customer ZAR Publications

Metal
Total Vinyl
Quantity
Date
Type Corners <u>nd</u>
Radius <u>1/4</u>
Completed

Ribbed Hinge

Gauge	Thick
Tear Seal <u>1 pt</u>	<u>1/2</u>
Bar Seal <u>Five-Test</u>	<u>1/2</u>
Bar Seal	

No. of Feet
Tear Seal
Bar Seal
Bar Seal

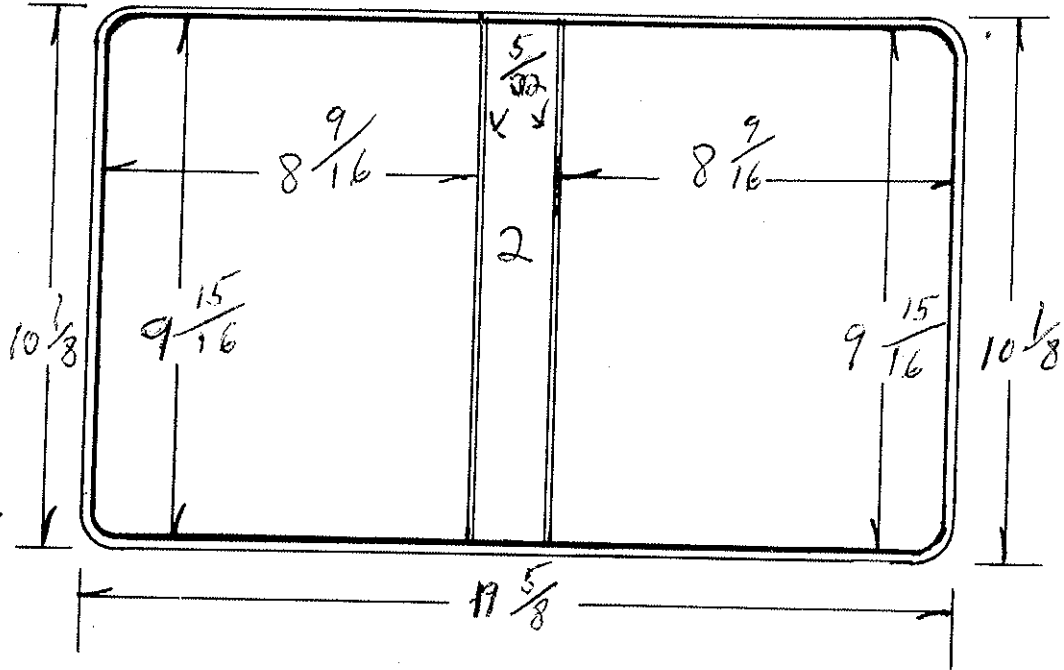

1 pt Ribbed hinge

Code		Cutting Specs				Code		Cutting Specs			
		Ga.	PCS	Size	Out			Ga.	PCS	Size	Out
Cover Mat.	$10 \frac{3}{4} \times 20 \frac{5}{16}$					Lining Mat.	$10 \frac{3}{4} \times 20 \frac{15}{16}$		1		
Cover Mat	X					Lining Mat.	X				
Vert. Pckt.	<u>Clear</u> $10 \frac{1}{8} \times 11 \frac{13}{16}$		1			Horz. Pckt.	X				
Vert. Pckt.	X					Horz. Pckt.	X				
Pocket	X					Pocket	X				
Label Holder	X					Card Holder	X				
Material	X					Material	X				
Material	X					Material	X				
Material	X					Material	X				
F.C. Board	$9 \frac{27}{32} \times 8 \frac{15}{16}$		1			B.C. Board	$9 \frac{27}{32} \times 8 \frac{15}{16}$		1		
B.C. Board	X					B.B. Board	$9 \frac{27}{32} \times 1 \frac{29}{32}$		1		
Center Board	X					Board	X				
Board	X					Strip	X				
Cover Pad	X					Strip	X				
						B.B. Pad	X				

Product Code

King Binder
Style Case Benson St. D

Sheet Size 9 X 6 1/2 Cap. 1 Die No. 3985 Order No. 958414 Plate

Customer

Z BR Publications

Metal
Total Vinyl .30
Quantity 200
Date 3-25-88
Type Corners RD
Radius 1/4
Completed 1/1

	Gauge	Thick
Tear Seal	.016	1 pt.
Bar Seal	254	cut
Bar Seal		

	No. of Feet
Tear Seal	
Bar Seal	
Bar Seal	

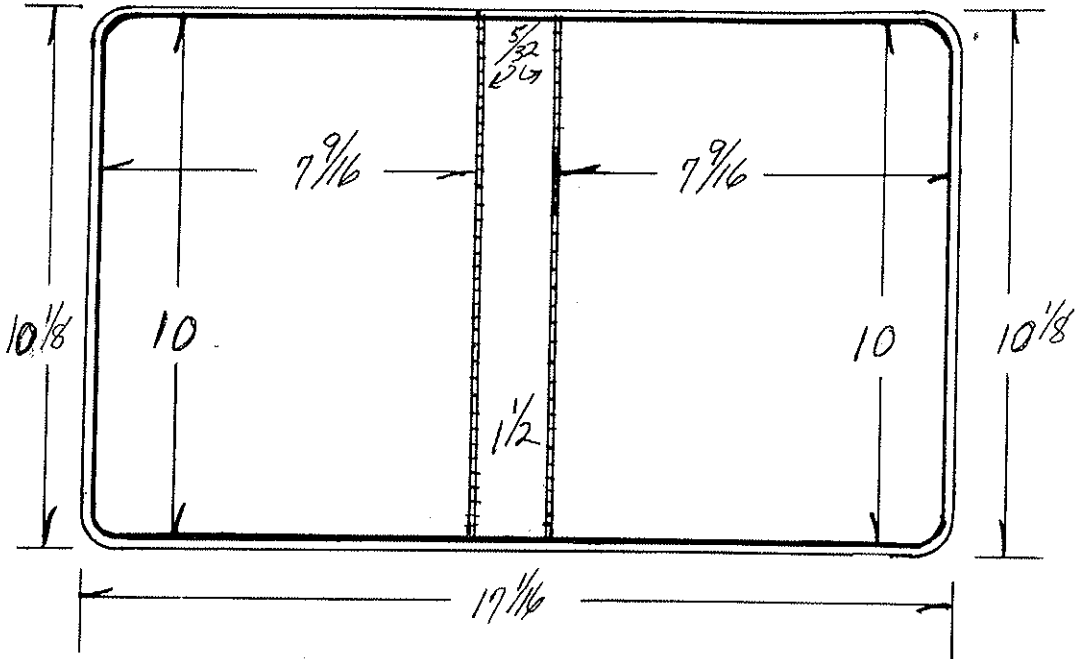

Back bone bar
to be cut.
Imitation everlast
hinge groove cut .016
deep

Code		Ga.	PCS	Size	Out	Cutting Specs.	Code		Ga.	PCS	Size	Out	Cutting Specs.
Cover Mat.	10 3/4 X 17 1/16		1				Lining Mat.	10 3/4 X 17 1/16		1			
Cover Mat.	X						Lining Mat.	X					
Vert. Pckt.	X						Horz. Pckt.	5 3/8 X 8 3/4		1			
Vert. Pckt.	X						Horz. Pckt.	10 3/16 X 10 1/4		1			
Pocket	X						Pocket	X					
Label Holder	X						Card Holder	X					
Material	X						Material	X					
Material	X						Material	X					
Material	X						Material	X					
F.C. Board	9 29/32 X 7 15/32	120	1				B.C. Board	9 29/32 X 7 15/32	120	1			
B.C. Board	9 15/16 X 7 1/2	100	2				B.B. Board	9 29/32 X 1 3/32	120	1			
Center Board	9 15/16 X 1 13/32	100	1				Board	X					
Board	X						Strip	X					
Cover Pad	X						Strip	X					
							B.B. Pad	X					

Product Code

Style Case *VRR*

Sheet Size *9 1/2 x 6 3/4* Cap. *2 1/2* Die No. *4024* Order No. *9588DJ* Plate

Customer *Weaver Paper Co*

Metal
Total Vinyl
Quantity
Date
Type Corners <i>Rd</i>
Radius <i>1/4</i>
Completed

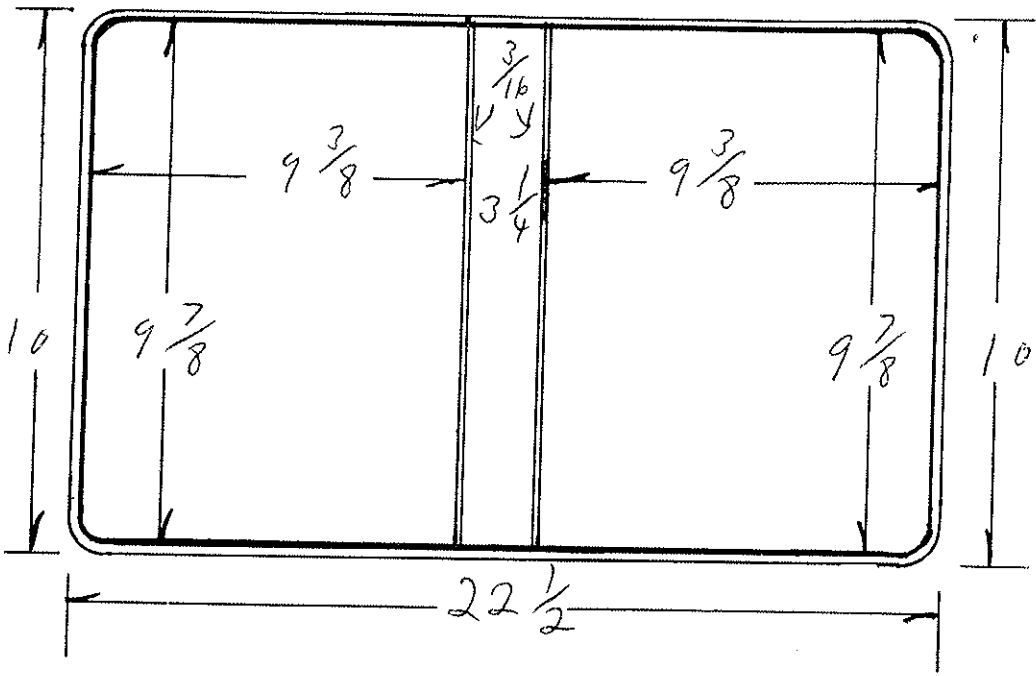

	Gauge	Thick
Tear Seal	<i>16</i>	<i>3/32</i>
Bar Seal	<i>178</i>	<i>3/16</i>
Bar Seal		

	No. of Feet
Tear Seal	
Bar Seal	
Bar Seal	

Code	Cutting Specs				Code	Cutting Specs			
	Ga.	PCS	Size	Out		Ga.	Pcs.	Size	Out
Cover Mat.		<i>10 5/8 x 23 1/8</i>		<i>1</i>	Lining Mat.		<i>10 5/8 x 23 1/8</i>		<i>1</i>
Cover Mat		X			Lining Mat.		X		
Vert. Pckt.		X			Horz. Pckt.		X		
Vert. Pckt.		X			Horz. Pckt.		X		
Pocket		X			Pocket		X		
Label Holder		X			Card Holder		X		
Material		X			Material		X		
Material		X			Material		X		
Material		X			Material		X		
F.C. Board		<i>9 25/32 x 9 9/32</i>		<i>1</i>	B.C. Board		<i>9 25/32 x 9 9/32</i>		<i>1</i>
B.C. Board		X			B.B. Board		<i>9 25/32 x 3 5/32</i>		<i>1</i>
Center Board		X			Board		X		
Board		X			Strip		X		
Cover Pad		X			Strip		X		
					B.B. Pad		X		

Product Code As Sample

Style Case VRB

Sheet Size 9 X 7 Cap. 1 Die No. 4053 Order No. 959677 Plate

Customer Digital Equipment Corp

Metal
Total Vinyl
Quantity
Date
Type Corners <u>Rd</u>
Radius <u>1/4</u>
Completed

	Gauge	Thick
Tear Seal	<u>16</u>	<u>3/32</u>
Bar Seal	<u>3/16</u>	<u>1/28</u>
Bar Seal		

	No. of Feet
Tear Seal	
Bar Seal	
Bar Seal	

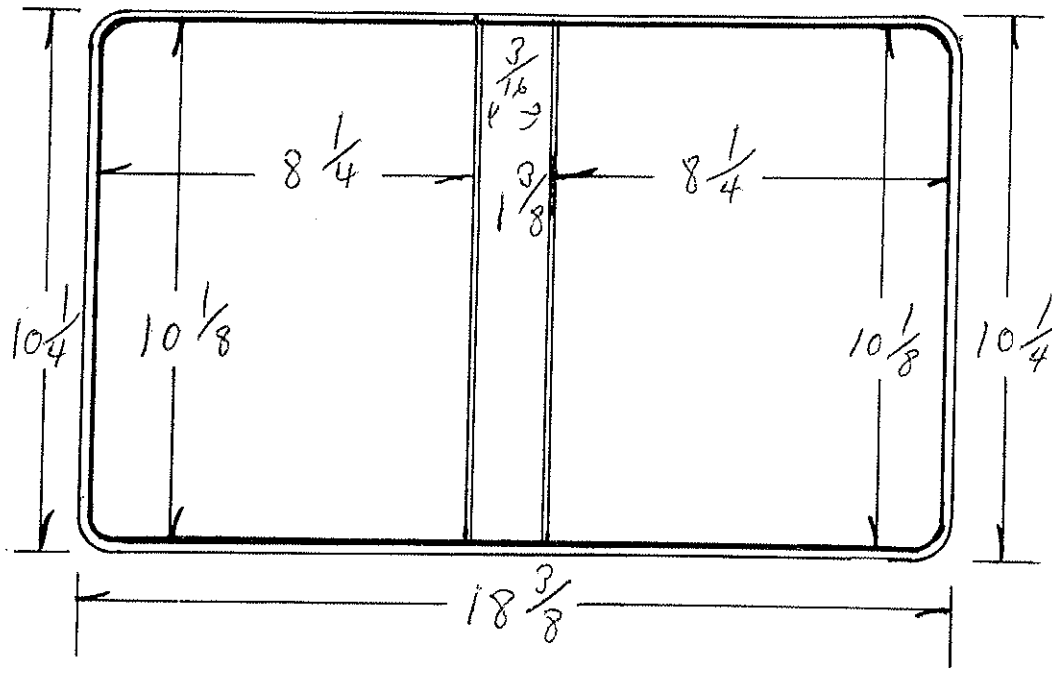

Code		Cutting Specs		Code		Cutting Specs			
		Ga.	PCS	Size	Out	Ga.	Pcs.	Size	Out
Cover Mat.	<u>10 7/8 X 19</u>		<u>1</u>			Lining Mat.		<u>10 7/8 X 19</u>	<u>1</u>
Cover Mat.	X					Lining Mat.		X	
Vert. Pckt.	X					Horz. Pckt.	<u>10 1/4 X 19</u>	<u>clear</u>	<u>1</u>
Vert. Pckt.	X					Horz. Pckt.	X		
Pocket	X					Pocket	X		
Label Holder	X					Card Holder	X		
Material	X					Material	X		
Material	X					Material	X		
Material	X					Material	X		
F.C. Board	<u>10 1/2 X 8 5/8</u>		<u>1</u>			B.C. Board	<u>10 1/2 X 8 5/8</u>		<u>1</u>
B.C. Board	X					B.B. Board	<u>10 1/2 X 1 9/32</u>		<u>1</u>
Center Board	X					Board	X		
Board	X					Strip	X		
Cover Pad	X					Strip	X		
						B.B. Pad	X		

Product Code

Style Case

SAR 2 (8 1/2 -

Sheet Size 9 x 7 1/2 Cap. 1 Die No. 4067 Order No. 960024 Plate

Customer Alliant Computer Systems

Metal
Total Vinyl
Quantity
Date
Type Corners <u>Rd</u>
Radius <u>1/4</u>
Completed

	Gauge	Thick
Tear Seal	<u>1 pt</u>	<u>16</u>
Bar Seal	<u>Fake</u>	<u>Hinge</u>
Bar Seal		

	No. of Feet
Tear Seal	
Bar Seal	
Bar Seal	

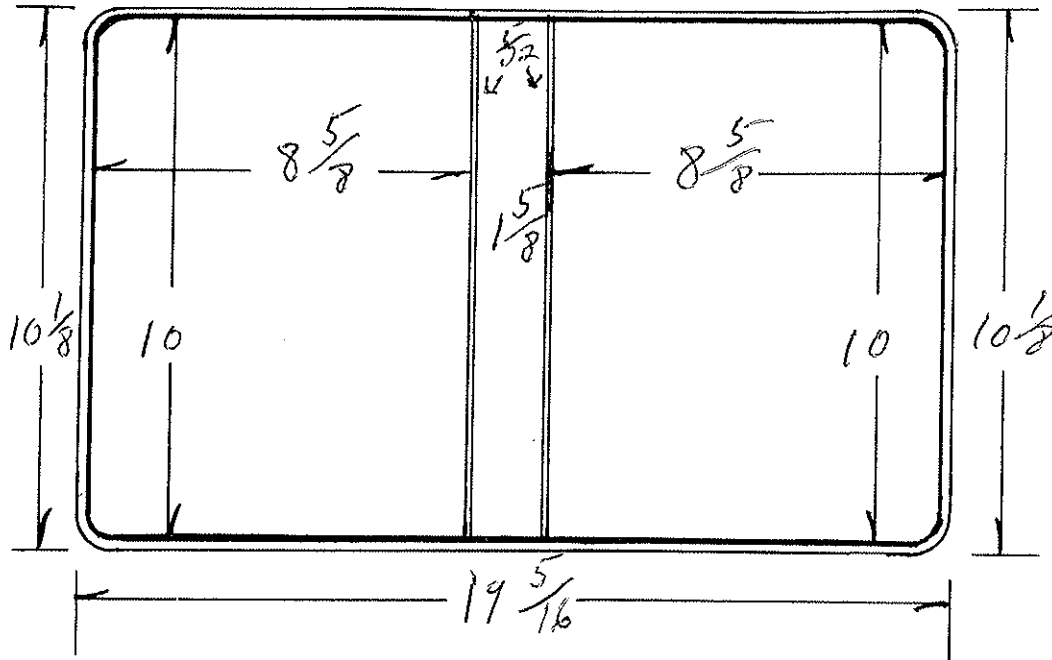

Code		Cutting Specs		Code		Cutting Specs			
		Ga.	# PCS	Size	Out	Ga.	Pcs.	Size	Out
Cover Mat.	<u>10 3/4 X 19 15/16</u>					Lining Mat.	<u>10 3/4 X 19 15/16</u>		<u>1</u>
Cover Mat.	X					Lining Mat.	X		
Vert. Pckt.	X					Horz. Pckt.	X		
Vert. Pckt.	<u>CDL 10 1/4 X 19 15/16</u>					Horz. Pckt.	X		
Pocket	X					Pocket	X		
Label Holder	<u>4 1/8 X 2</u>		<u>1</u>			Card Holder	X		
Material	X					Material	X		
Material	X					Material	X		
Material	X					Material	X		
F.C. Board	<u>9 29/32 X 8 17/32</u>		<u>1</u>			B.C. Board	<u>9 29/32 X 8 17/32</u>		<u>1</u>
B.G. Board	<u>9 15/16 X 8 9/16</u>		<u>2</u>			B.B. Board	<u>9 29/32 X 1 13/32</u>		<u>1</u>
Center Board	<u>9 15/16 X 1 17/32</u>		<u>1</u>			Board	X		
Board	X					Strip	X		
Cover Pad	X					Strip	X		
						B.B. Pad	X		

Product Code

Style Case

Ring Binder

Sheet Size

$9\frac{1}{2} \times 7$

Cap. 1

Die No. 4079

Order No. 960301

Plate

Customer

The International Group

Metal
Total Vinyl
Quantity
Date
Type Corners <i>RD</i>
Radius <i>1/4</i>
Completed

	Gauge	Thick
Tear Seal	16	<i>3/32</i>
Bar Seal	128	<i>3/16</i>
Bar Seal		

	No. of Feet
Tear Seal	
Bar Seal	
Bar Seal	

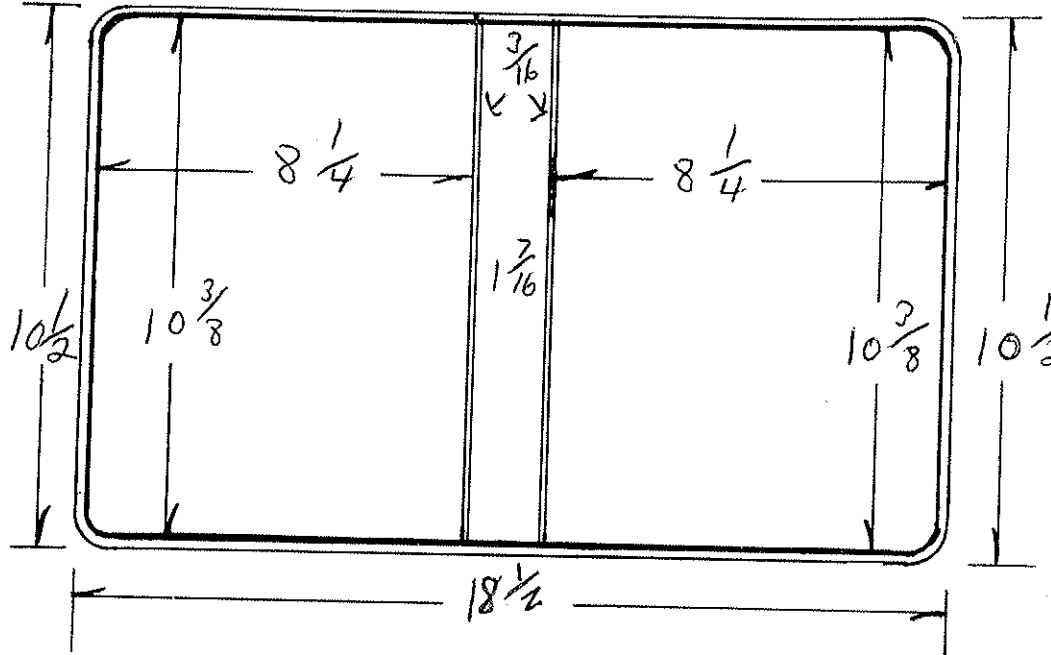

Code	Ga.	Pcs	Cutting Specs		Code	Ga.	Pcs.	Specs	
			Size	Out				Size	Out
Cover Mat.			$11\frac{1}{8} \times 19\frac{1}{4}$	1	Lining Mat.			$11\frac{1}{8} \times 19\frac{1}{4}$	1
Cover Mat			X		Lining Mat.			X	
Vert. Pckt.			X		Horz. Pckt.			X	
Vert. Pckt.			$10\frac{1}{2} \times 8\frac{3}{8}$	1	Horz. Pckt. 1-side			$4\frac{3}{8} \times 8\frac{3}{4}$	
Pocket			X		Pocket			X	
Label Holder			X		Card Holder			X	
Material			X		Material			X	
Material			X		Material			X	
Material			X		Material			X	
F.C. Board			$10\frac{9}{32} \times 8\frac{5}{32}$	120	B.C. Board			$10\frac{5}{16} \times 8\frac{3}{16}$	100
B.C. Board			$10\frac{9}{32} \times 8\frac{5}{32}$	120	B.B. Board			$10\frac{5}{16} \times 8\frac{3}{16}$	100
Center Board			$10\frac{9}{32} \times 1\frac{11}{32}$	120	Board			$10\frac{5}{16} \times 1\frac{11}{32}$	100
Board			X		Strip			X	
Cover Pad			X		Strip			X	
					B.B. Pad			X	

Product Code Overall FC. 10 1/4 x 9 7/8

Style Case Koloman St. D Rings

Sheet Size 9 X 7

Cap. 2

Die No. 4080

Order No. 960241

Plate

Customer

Z B R Publications

Metal
Total Vinyl <u>.030</u>
Quantity <u>500</u>
Date <u>9/23/88</u>
Type Corners <u>Rd</u>
Radius <u>1/4</u>
Completed

	Gauge	Thick
Tear Seal	<u>.016</u>	<u>3/32</u>
Bar Seal	<u>imitation</u>	<u>overlast</u>
Bar Seal	<u>hinge</u>	<u>4.0mm</u>

	No. of Feet
Tear Seal	
Bar Seal	
Bar Seal	

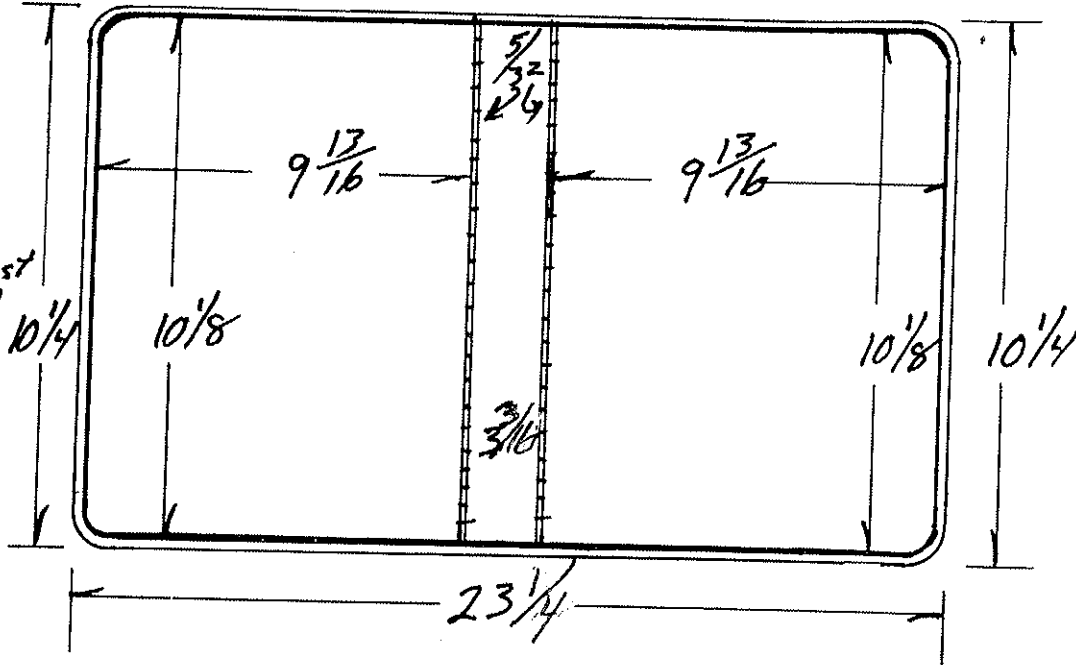

Code		Cutting Specs		Code		Cutting Specs			
		Ga.	# PCS	Size	Out	Ga.	Pcs.	Size	Out
Cover Mat.	<u>11 x 24</u>		<u>1</u>			Lining Mat.	<u>11 x 24</u>		<u>1</u>
Cover Mat.	X					Lining Mat.	X		
Vert. Pckt.	X					Horz. Pckt.	<u>5 3/8 x 24</u>		<u>1</u>
Vert. Pckt.	X					Horz. Pckt.	X		
Pocket	X					Pocket	X		
Label Holder	X					Card Holder	X		
Material	X					Material	X		
Material	X					Material	X		
Material	X					Material	X		
F.C. Board	<u>10 1/32 x 9 23/32</u>		<u>1</u>			B.C. Board	<u>10 1/32 x 9 23/32</u>		<u>1</u>
B.C. Board	X					B.B. Board	<u>10 1/32 x 3 3/32</u>		<u>1</u>
Center Board	X					Board	X		
Board	X					Strip	X		
Cover Pad	X					Strip	X		
						B.B. Pad	X		

Product Code

old die 2085

Style Case Ring Binder

Sheet Size $9\frac{1}{2} \times 7$

Cap. 2

Die No. 4083

Order No. 966272

Plate

Customer

University of Kentucky

Metal
Total Vinyl
Quantity 400
Date 10-3-88
Type Corners R ₂
Radius $\frac{1}{4}$
Completed

	Gauge	Thick
Tear Seal	016	$\frac{3}{32}$
Bar Seal	253	$\frac{1}{8}$
Bar Seal		

	No. of Feet
Tear Seal	
Bar Seal	
Bar Seal	

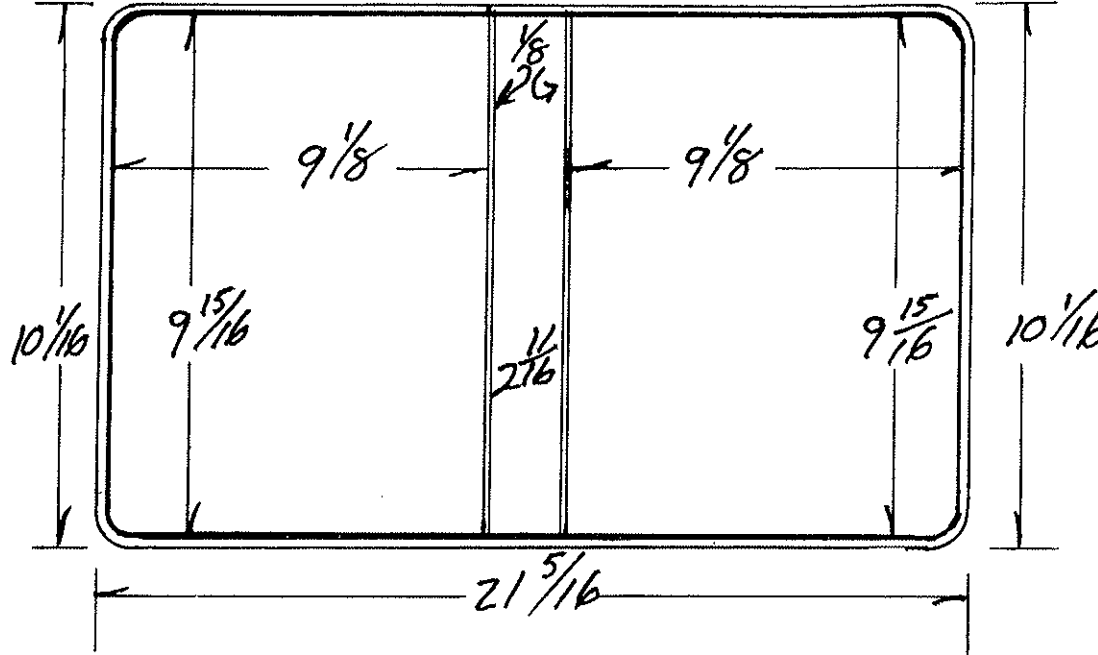

Code	Ga.	PCS	Cutting Specs		Code	Ga.	Pcs.	Cutting Specs		
			Size	Out				Size	Out	
Cover Mat.			$10\frac{1}{16} \times 21\frac{5}{16}$	1	Lining Mat.			$10\frac{1}{16} \times 21\frac{5}{16}$	1	
Cover Mat.			X		Lining Mat.			X		
Vert. Pckt.			X		Horz. Pckt.			X		
Vert. Pckt.			X		Horz. Pckt.			X		
Pocket			X		Pocket			X		
Label Holder			X		Card Hlder			X		
Material			X		Material			X		
Material			X		Material			X		
Material			X		Material			X		
F.C. Board			$9\frac{27}{32} \times 9\frac{1}{32}$	120	1	B.C. Board		$9\frac{27}{32} \times 9\frac{1}{32}$	120	1
B.G. Board			$9\frac{7}{8} \times 9\frac{1}{16}$	100	2	B.B. Board		$9\frac{27}{32} \times 2\frac{1}{32}$	120	1
Center Board			$9\frac{7}{8} \times 2\frac{9}{32}$	100	1	Board		X		
Board			X		Strip			X		
Cover Pad			X		Strip			X		
					B.B. Pad			X		

Product Code

Style Case **VRB**

Sheet Size **9 1/2 x 6 1/2** Cap. **3/4** Die No. **4225**

Order No. **962777** Plate

Customer **COLTON INSTRUCTIONAL SYSTEMS**

Metal
Total Vinyl
Quantity
Date
Type Corners
Radius
Completed

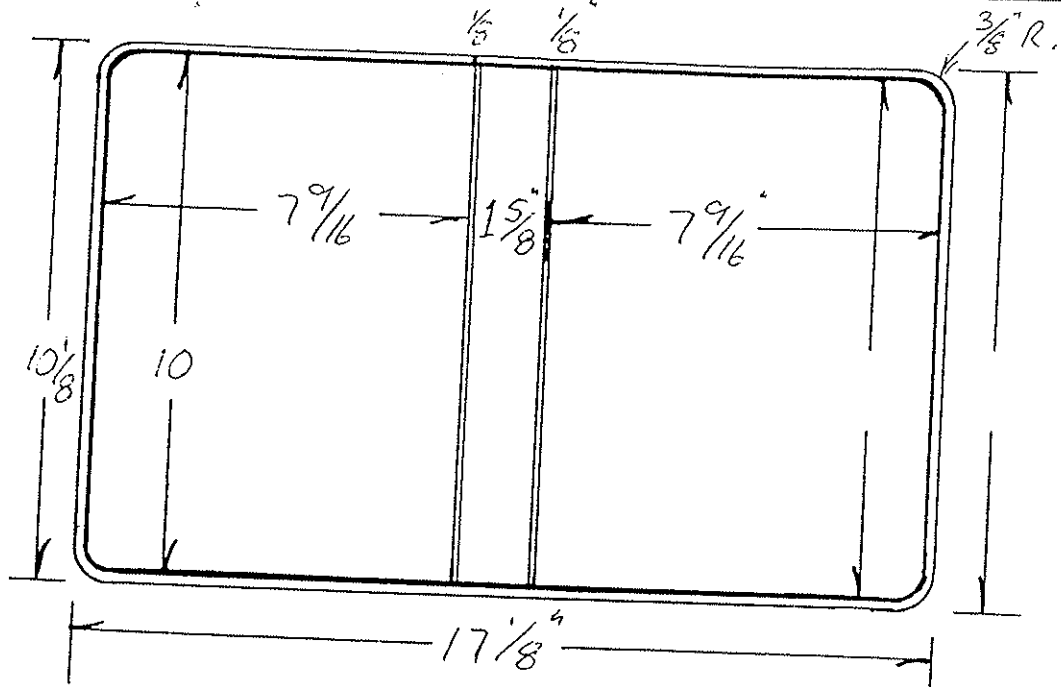

	Gauge	Thick
Tear Seal	.016	3/32
Bar Seal	#253	1/8
Bar Seal		

	No. of Feet
Tear Seal	
Bar Seal	
Bar Seal	

Code	Ga.	# PCS	Cutting Specs		Code	Ga.	# Pcs.	Cutting Specs		Specs	Time
			Size	Out				Size	Out		
Cover Mat.	10 7/8	15	1		Lining Mat.	10 7/8	15	1			
Cover Mat	X				Lining Mat.	X					
vert. Pckt.	X				Horz. Pckt. I.B.C.	3 5/8	8	1	8 1/4		
vert. Rckt.	X				Horz. Pckt.	X					
Pocket	X				Pocket	X					
Label Holder	X				Card Holder	X					
Material	X				Material	X					
Material	X				Material	X					
Material	X				Material	X					
B.C. Board	9 29/32	120	1		B.C. Board	9 13/16	100	1	7 1/2		
B.C. Board	9 29/32	120	1		B.B. Board	9 15/16	100	1	1 1/32		
Center Board	9 29/32	120			Board	9 15/16	100	1	7 1/2		
Board	X				Strip	X					
Cover Pad	X				Strip	X					
					B.B. Pad	X					

Product Code

Style Case **D-VRB**

Sheet Size **9 1/2 X 7** Cap. **1** Die No. **4231**

Order No. **962783** Plate

Customer **UNIVERSITY OF KENTUCKY**

Metal
Total Vinyl
Quantity 500
Date 6-27-89
Type Corners RND
Radius 3/8"
Completed

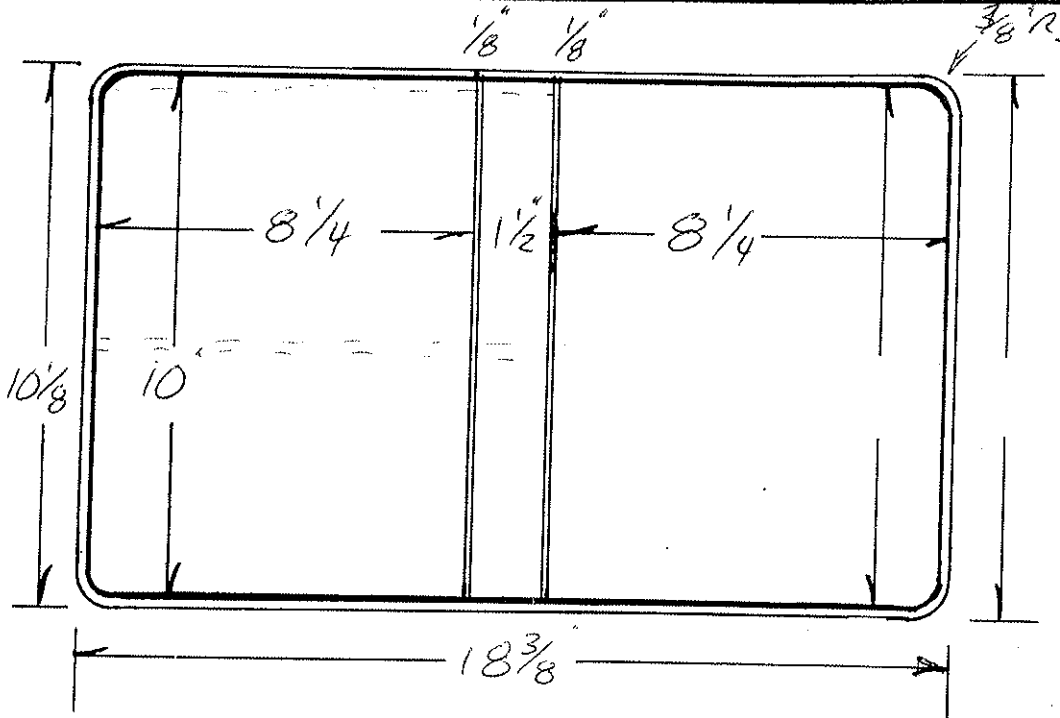

	Gauge	Thick
Tear Seal	016	3/2
Bar Seal	#25-4	1/8
Bar Seal		

	No. of Feet
Tear Seal	
Bar Seal	
Bar Seal	

Code		Ga. # PCS		Cutting Specs		Code		Ga. # PCS		Cutting Specs	
				Size	Out					Size	Out
Cover Mat.	10 7/8 X 19 1/4	15	1			Lining Mat.	10 7/8 X 19 1/4	15	1		
Cover Mat.	X					Lining Mat.	X				
Vert. Pckt.	X					Horz. Pckt.	X				
Vert. Pckt.	X					Horz. Pckt.	X				
Pocket	X					Pocket	X				
Label Holder	X					Card Hlder	X				
Material	X					Material	COL. 4 7/8 X 10 7/8	8	1		
Material	X					Material	X				
Material	X					Material	X				
F.C. Board	9 29/32 X 8 5/32	120	1			B.C. Board	9 15/16 X 8 3/16	100			
B.C. Board	9 29/32 X 8 5/32	120	1			B.B. Board	9 15/16 X 1 7/32	100	1		
Center Board	9 29/32 X 1 3/32	120	1			Board	9 15/16 X 8 3/16	100	1		
Board	X					Strip	X				
Cover Pad	X					Strip	X				
						B.B. Pad	X				

Product Code

Style Case

D-VRB

Sheet Size $9\frac{1}{2} \times 7$ Cap. 2 Die No. 4236 Order No. 962781 Plate

Customer

UNIVERSITY OF KENTUCKY

Metal	
Total Vinyl	
Quantity	300
Date	6-28-89
Type Corners	RND
Radius	$3\frac{1}{8}$ "
Completed	

	Gauge	Thick
Tear Seal	016	$\frac{3}{32}$
Bar Seal	425	
Bar Seal		

	No. of Feet
Tear Seal	
Bar Seal	
Bar Seal	

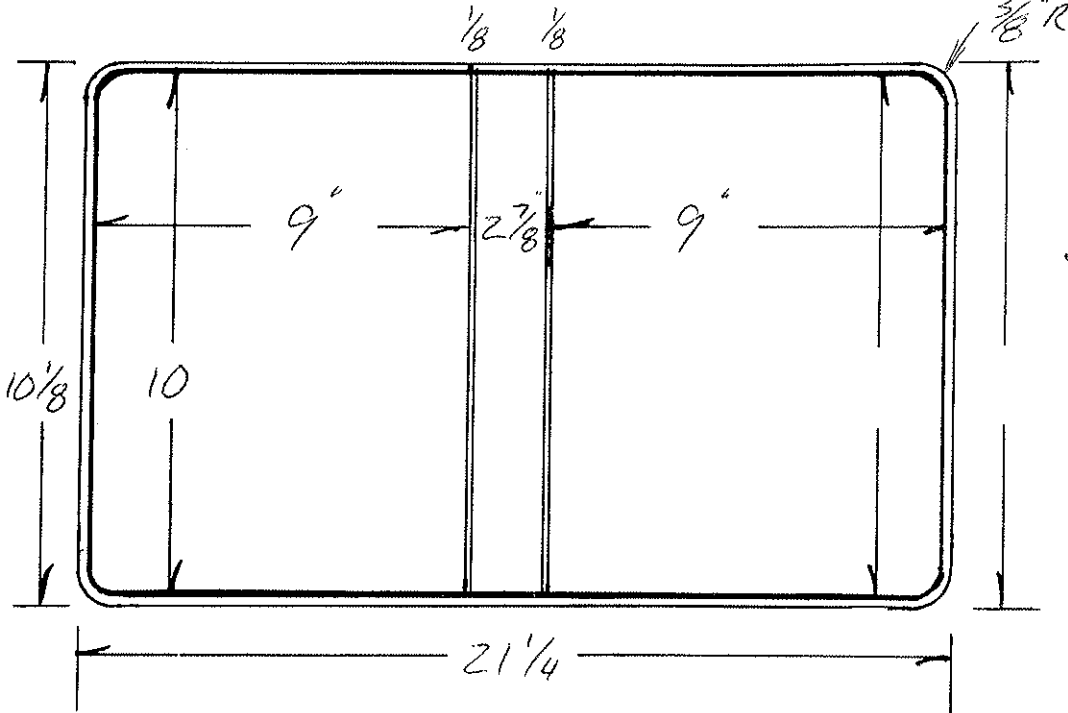

Code	Ga.	PCS	Cutting Specs.		Code	Ga.	Pcs.	Cutting Specs.		
			Size	Out				Size	Out	
Cover Mat.			$10\frac{1}{8} \times 22$	15	1	Lining Mat.		$10\frac{1}{8} \times 22$	15	1
Cover Mat			X			Lining Mat.		X		
Vert. Pckt.			X			Horz. Pckt.		X		
Vert. Pckt.			X			Horz. Pckt.		X		
Pocket			X			Pocket		X		
Label Holder			X			Card Holder		X		
Material			X			Material	COL	$4\frac{3}{8} \times 13$	8	1
Material			X			Material		X		
Material			X			Material		X		
F.C. Board			$9\frac{29}{32} \times 8\frac{29}{32}$	120	1	B.C. Board		X		
B.C. Board			$9\frac{29}{32} \times 8\frac{29}{32}$	120	1	B.B. Board		$9\frac{29}{32} \times 2\frac{25}{32}$	120	1
Center Board			X			Board		X		
Board			X			Strip		X		
Cover Pad			X			Strip		X		
						B.B. Pad		X		

Product Code

Style Case *ANGLE D VRB*

Sheet Size *9 3/4 x 7 1/4* Cap. *1 1/2* Die No. *4275* Order No. *963450851* Plate

Customer

TRI - VILLAGE PRINTING

Metal
Total Vinyl
Quantity <i>90190 - 180</i>
Date <i>9-11-89</i>
Type Corners
Radius <i>3/8</i>
Completed

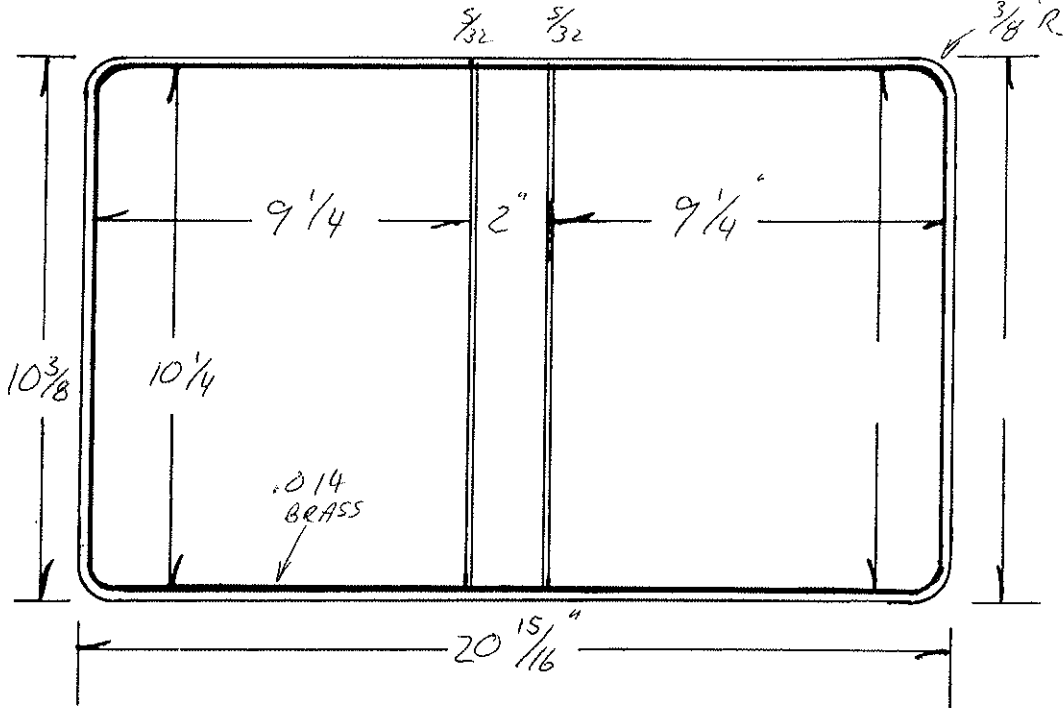

	Gauge	Thick
Tear Seal	<i>.014</i>	<i>3/32</i>
Bar Seal	<i>#254</i>	<i>5/32</i>
Bar Seal		

	No. of Feet
Tear Seal	
Bar Seal	
Bar Seal	

Code	Ga.	#	Cutting Specs		Code	Ga.	#	Cutting Specs	
			Size	Out				Size	Out
Cover Mat.			<i>11 1/4</i>	<i>X 21 3/4</i>		<i>15</i>	<i>1</i>		
Cover Mat.				X	Lining Mat.			<i>11 1/4</i>	<i>X 21 3/4</i>
Vert. Pckt.				X	Lining Mat.				X
Vert. Pckt.				X	Horz. Pckt.				X
Pocket				X	Horz. Pckt.				X
Label Holder				X	Pocket				X
Material				X	Card Holder				X
Material				X	Material				X
Material				X	Material				X
F.C. Board			<i>10 5/32</i>	<i>X 9 5/32</i>	B.C. Board				X
B.C. Board			<i>10 5/32</i>	<i>X 9 5/32</i>	B.B. Board			<i>10 5/32</i>	<i>X 1 29/32</i>
Center Board				X	Board				X
Board				X	Strip				X
Cover Pad				X	Strip				X
					B.B. Pad				X

Product Code

Style Case

VRB

Sheet Size 9 x 8 Cap. 1 Die No. 4277 Order No. 963572 Plate

Customer

DIGITAL COMMUNICATIONS

Metal
Total Vinyl
Quantity <u>1000</u>
Date <u>9-12-85</u>
Type Corners
Radius <u>3/8"</u>
Completed

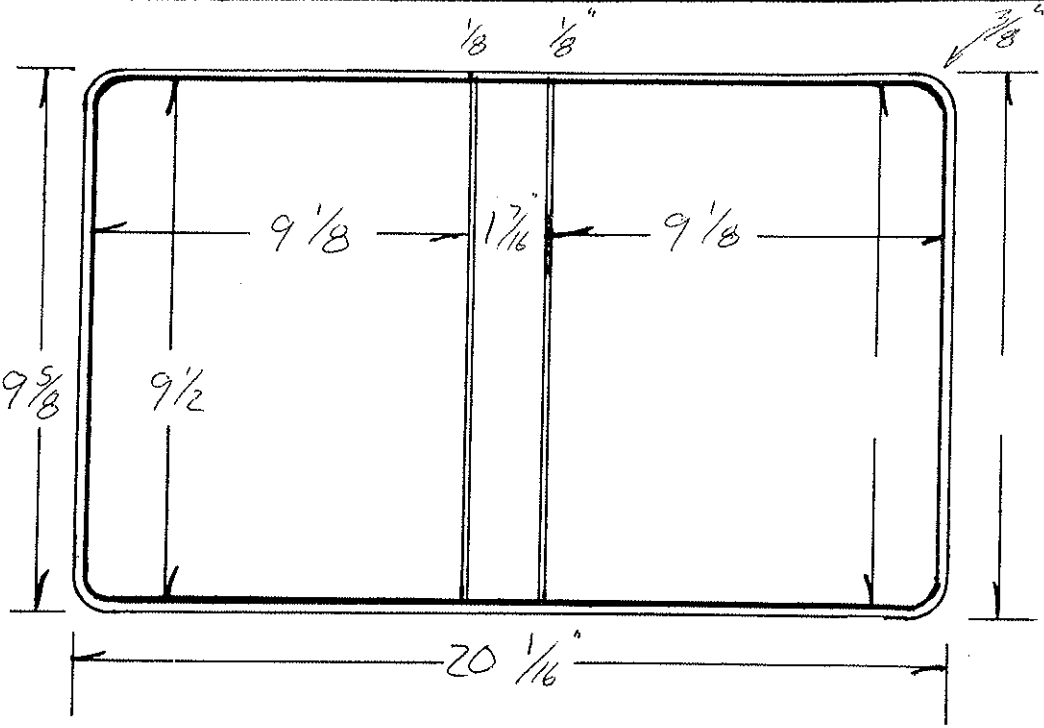

	Gauge	Thick
Tear Seal	#016"	3/32
Bar Seal	#253	1/8
Bar Seal		

	No. of Feet
Tear Seal	
Bar Seal	
Bar Seal	

Code	Ga.	# PCS	Cutting Specs		Code	Ga.	# Pcs.	Cutting Specs	
			Size	Out				Size	Out
Cover Mat.			10 1/2 X 20 7/8	15 1	Lining Mat.			10 1/2 X 20 7/8	15 1
Cover Mat			X		Lining Mat.			X	
Vert. Pckt.			X		Horz. Pckt.			X	
Vert. Pckt.			X		Horz. Pckt.			X	
Pocket			X		Pocket			X	
Label Holder			X		Card Holder			X	
Material			X		Material			X	
Material			X		Material			X	
Material			X		Material			X	
F.C. Board			9 13/32 X 9 1/32	100 1	B.C. Board			X	
B.C. Board			9 13/32 X 9 1/32	100 1	B.B. Board			9 13/32 X 1 1/32"	100 1
Center Board			X		Board			X	
Board			9 7/16 X 9 1/16	100 2	Strip			X	
Cover Pad			9 7/16 X 1 1/32	100 1	Strip			X	
					B.B. Pad			X	

Product Code

NATURAL-VRB
Style Case

Sheet Size $9\frac{1}{2}$ X $6\frac{1}{2}$ Cap. $1\frac{1}{2}$ Die No. 4280 Order No. 963584E3 Plate

Customer

NORTHERN TELECOM

Metal
Total Vinyl
Quantity 1+ 2500
Date 9-14-89
Type Corners RND.
Radius $\frac{3}{8}$
Completed

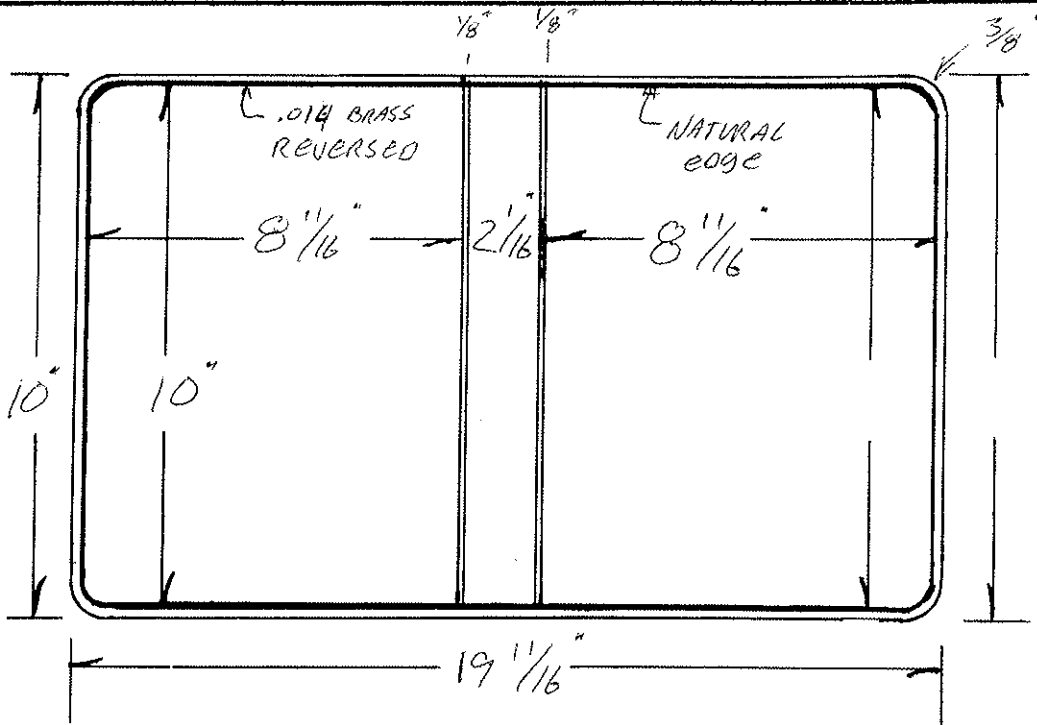

	Gauge	Thick
Tear Seal	.014	$\frac{1}{16}$ "
Bar Seal	REVERSCO	
Bar Seal		

	No. of Feet
Tear Seal	
Bar Seal	
Bar Seal	

Code	Ga.	PCS	Cutting Specs		Code	Ga.	Pcs.	Cutting Specs			
			Size	Out				Size	Out		
Cover Mat.			$10\frac{3}{4}$ X $20\frac{1}{2}$	12	1	Lining Mat.			$10\frac{3}{4}$ X $20\frac{1}{2}$	15	1
Cover Mat.			X			Lining Mat.			X		
Vert. Pckt.			X			Horz. Pckt.			X		
Vert. Pckt.			X			Horz. Pckt.			X		
Pocket			X			Pocket			X		
Label Holder			X			Card Hlder			X		
Material			X			Material			X		
Material			X			Material			X		
Material			X			Material			X		
F.C. Board			$9\frac{29}{32}$ X $8\frac{19}{32}$	100	1	B.C. Board			X		
B.C. Board			$9\frac{29}{32}$ X $8\frac{19}{32}$	100	1	B.B. Board			$9\frac{29}{32}$ X $1\frac{3}{32}$		
Center Board			X			Board			X		
Board			X			Strip			X		
Cover Pad			X			Strip			X		
						B.B. Pad			X		

Product Code

Style Case STR. O. VRB

Sheet Size 9 x 7 7/8 Cap. 1

Die No. 4312

Order No. 963937

Plate

Customer

MICROGRAPHX

Metal
Total Vinyl
Quantity 100
Date 10-27-69
Type Corners
Radius 3/8"
Completed 10-27-69 RET

	Gauge	Thick
Tear Seal	.016	1/16"
Bar Seal	#254	3/32
Bar Seal		

	No. of Feet
Tear Seal	
Bar Seal	
Bar Seal	

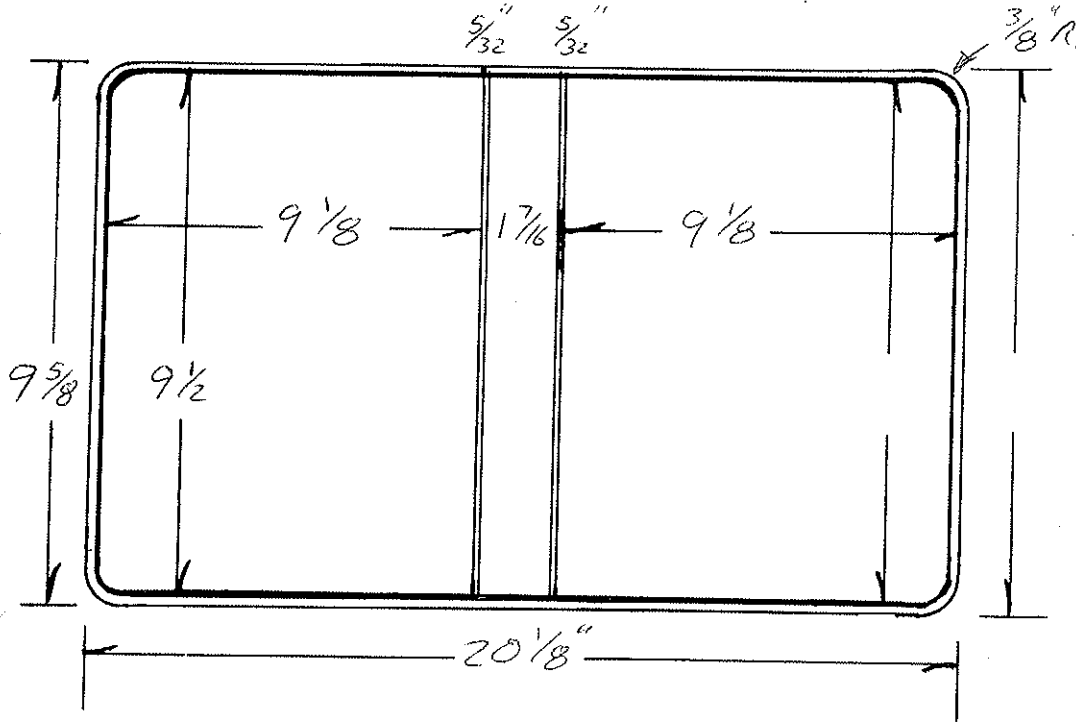

11-1

SIZE BY: B.P.

CHECK BY: *pp*

Code		Ga.		# PCS		Cutting Specs		Code		Ga.		# PCS		Cutting Specs	
						Size	Out					Size	Out		
Cover Mat.		10 1/2	X	21	15	1		Lining Mat.		10 1/2	X	21	15	1	
Cover Mat		X						Lining Mat.		X					
Vert. Pckt.		X						Horz. Pckt.	3 1/8 Pkt.	3 7/8	X	21	15	1	
Vert. Pckt.		X						Horz. Pckt.		X					
Pocket		X						Pocket		X					
Label Holder		X						Card Holder	GLASS	X					
Material		X						Material	C.O.L.	9 3/4	X	21	8	1	
Material		X						Material		X					
Material		X						Material		X					
F.C. Board		9 1/32	X	9 1/32	100	1		B.C. Board		9 1/32	X	1 1/32	100	1	
B.C. Board		9 1/32	X	9 1/32	100	1		B.B. Board		9 7/16	X	1 1/32	100	1	
Center Board	PC BC	9 7/16	X	9 1/16	100	2		Board		X					
Board		X						Strip		X					
Cover Pad		X						Strip		X					
								B.B. Pad		X					

Product Code

Style Case STR.O. VRCB

Sheet Size 9 X 7 7/8 Cap. 2

Die No. 4313

Order No. 963938

Plate

Customer

MICROGRAPHX

Metal
Total Vinyl
Quantity
Date <u>10-27-69</u>
Type Corners
Radius <u>3/8"</u>
Completed <u>10-27-69</u>

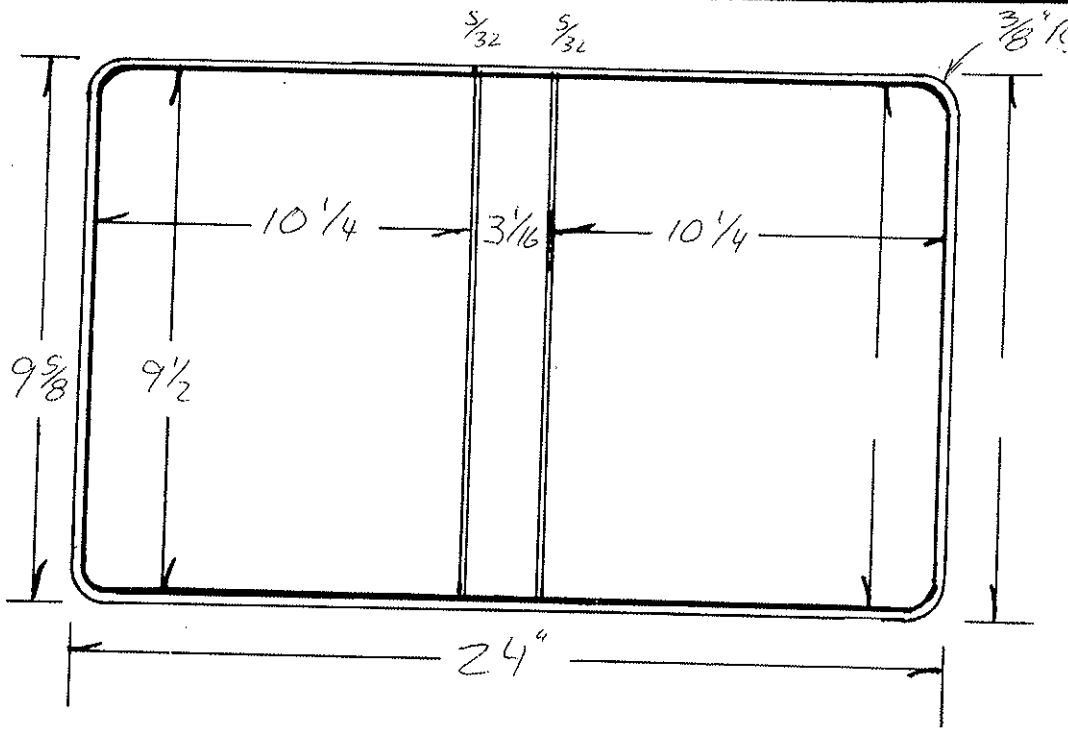

	Gauge	Thick
Tear Seal	<u>.016</u>	<u>7/16"</u>
Bar Seal	<u>#254</u>	<u>3/32</u>
Bar Seal		

	No. of Feet
Tear Seal	
Bar Seal	
Bar Seal	

11-1
 SIZE BY: B.P.
 CHECK BY: K.P.

Code		Cutting Specs		Code		Cutting Specs				
		Ga.	# PCS	Size	Out	Ga.	# Pcs.	Size	Out	
Cover Mat.	<u>10 1/2 X 24 3/4</u>	<u>15</u>	<u>1</u>			Lining Mat.		<u>10 1/2 X 24 3/4</u>	<u>15</u>	<u>1</u>
Cover Mat	X					Lining Mat.	X			
Vert. Pckt.	X					Horz. Pckt.	X			
Vert. Pckt.	X					Horz. Pckt	<u>3/16 Pkt.</u>	<u>3 7/8 X 24 3/4</u>	<u>15</u>	<u>1</u>
Pocket	X					Pocket	X			
Label Holder	X					Card Holder	<u>GLASS</u>	X		
Material	X					Material	<u>L.O.L</u>	<u>9 3/4 X 24 3/4</u>	<u>8</u>	<u>1</u>
Material	X					Material	X			
Material	X					Material	X			
F.C. Board	<u>9 13/32 X 10 5/32</u>	<u>100</u>	<u>1</u>			B.C. Board	X			
B.C. Board	<u>9 13/32 X 10 5/32</u>	<u>100</u>	<u>1</u>			B.B. Board	<u>9 13/32 X 2 3/32</u>	<u>100</u>	<u>1</u>	
Center Board	X					Board	X			
Board	X					Strip	X			
Cover Pad	X					Strip	X			
						B.B. Pad	X			

DIE #	6453	METAL	STR D N/B	RADIUS	3/8"
ORDER #	989451	CUSTOMER	SUNTRUST BANK	TEAR SEAL	.012
SHEET SIZE	9 X 6 1/2	STYLE CASE	VINYL BINDER	BAR SEAL	253
CAP.	2 1/2"	DUE DATE	3-31-98	COMPLETED	
LOCATION	Q-1-8	QUANTITY	1200	DATE	3-16-98

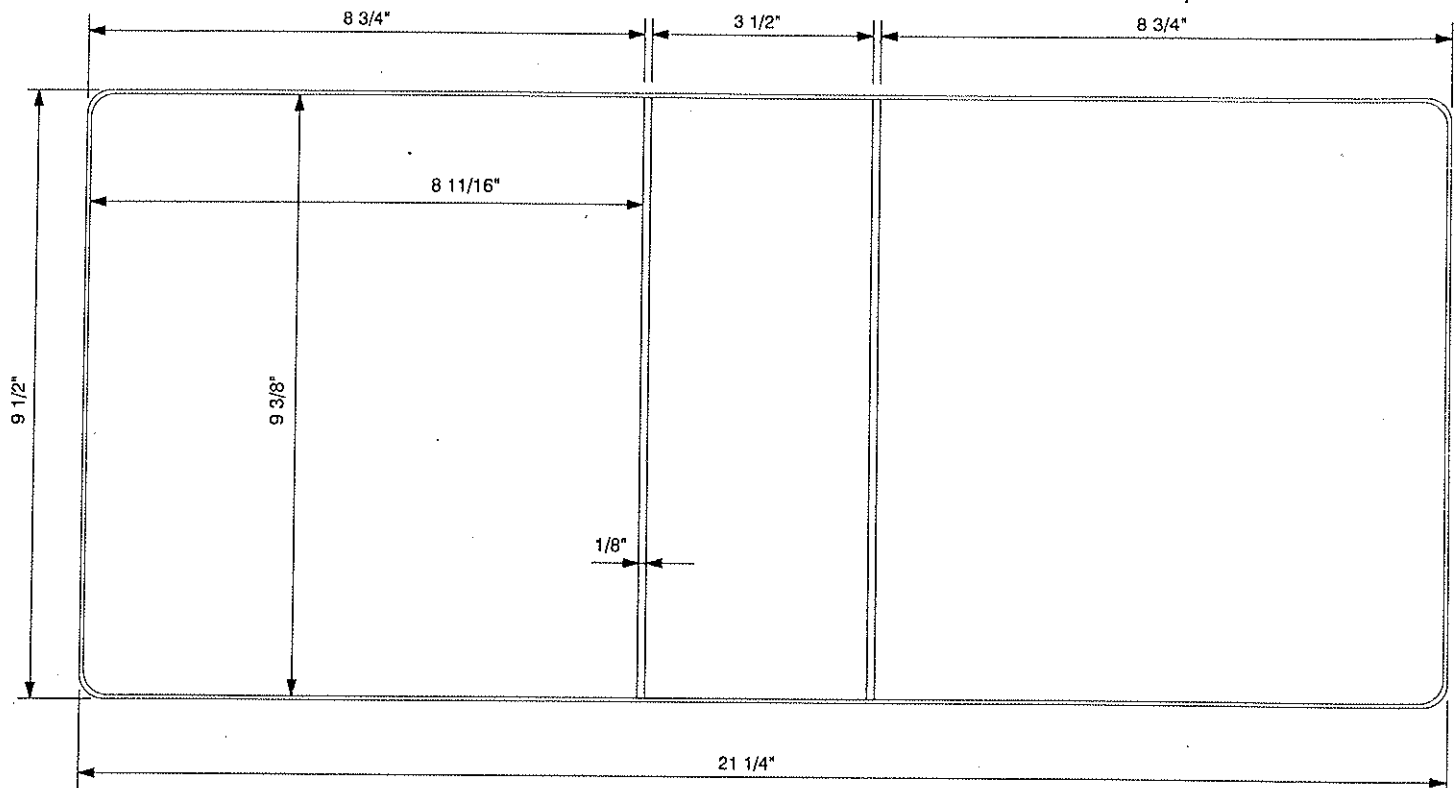

MATERIAL SPECS		GAUGE		MATERIAL SPECS		GAUGE	
COVER MAT.	10 1/4 X 22		1	LINING MAT.	10 1/4 X 22		1
COVER MAT.				LINING MAT.			
DIE CUT				HORZ. PKT.	4 7/8 X 22		
COL				VERT. PKT.			
LABEL HOLDER				DIE CUT			
GUSSET				REINF.			

BOARD SPECS		GAUGE		BOARD SPECS		GAUGE	
F.C. BOARD	9 5/16 X 8 5/8	120	1	F.C. BOARD			
B.B. BOARD	9 5/16 X 3 13/16	120	1	B.B. BOARD			
B.C. BOARD	9 5/16 X 8 5/8	120	1	B.C. BOARD			
FLAP BD.				DIE CUT			
BOARD				DIE CUT			

DIE #	6456	METAL	2.5 STR D NB 8.5	RADIUS	3/8"
ORDER #	989513	CUSTOMER	HART GRAPHICS	TEAR SEAL	.012
SHEET SIZE	9 X 7 1/2	STYLE CASE	VINYL BINDER	BAR SEAL	253
CAP.	2 1/2"	DUE DATE	3-31-98	COMPLETED	
LOCATION		QUANTITY	300	DATE	3-18-98

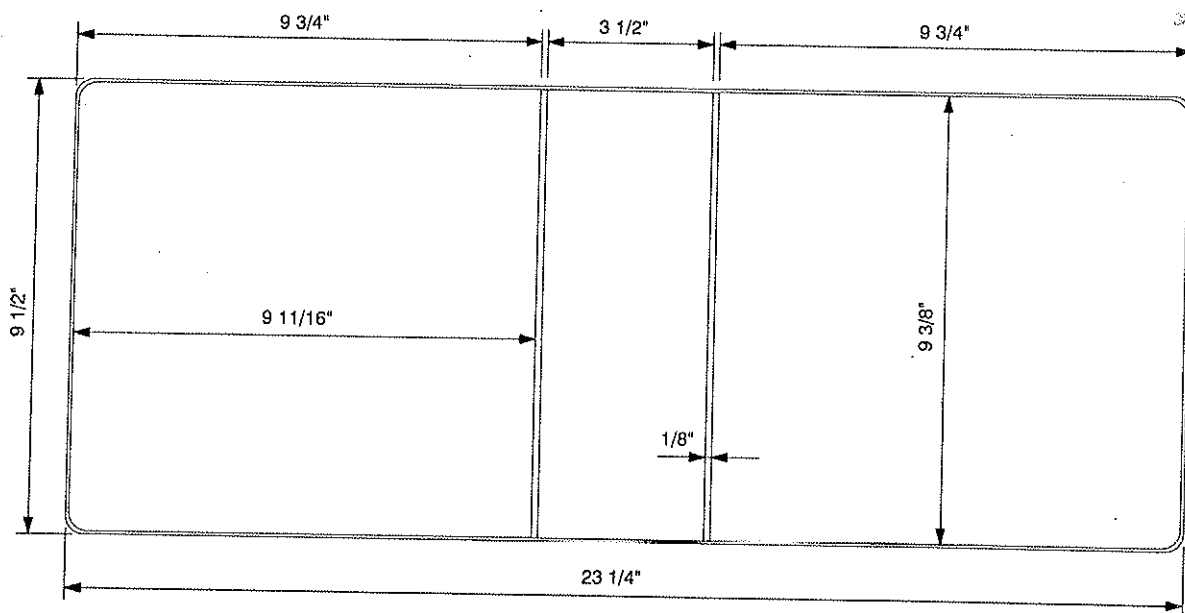

MATERIAL SPECS		GAUGE		PCS.		MATERIAL SPECS		GAUGE		PCS.	
COVER MAT.	10 1/4 X 24			1		LINING MAT.	10 1/4 X 24			1	
COVER MAT.						LINING MAT.					
DIE CUT						HORZ. PKT.					
COL	9 11/16 X 24			1		VERT. PKT.					
LABEL HOLDER						DIE CUT					
GUSSET						REINF.					
BOARD SPECS		GAUGE		PCS.		BOARD SPECS		GAUGE		PCS.	
F.C. BOARD	9 5/16 X 9 5/8	120	1			F.C. BOARD					
B.B. BOARD	9 5/16 X 13/32	120	1			B.B. BOARD					
B.C. BOARD	9 5/16 X 9 5/8	120	1			B.C. BOARD					
FLAP BD.						DIE CUT					
BOARD						DIE CUT					

DIE #	6453-R	METAL	STR D N/B	RADIUS	3/8"
ORDER #	989451	CUSTOMER	SUNTRUST BANK	TEAR SEAL	.012
SHEET SIZE	9 X 6 1/2	STYLE CASE	VINYL BINDER	BAR SEAL ^	253
CAP.	1 1/2"	DUE DATE	3-31-98	COMPLETED	
LOCATION	Q-1-8	QUANTITY	1200	DATE	3-23-98

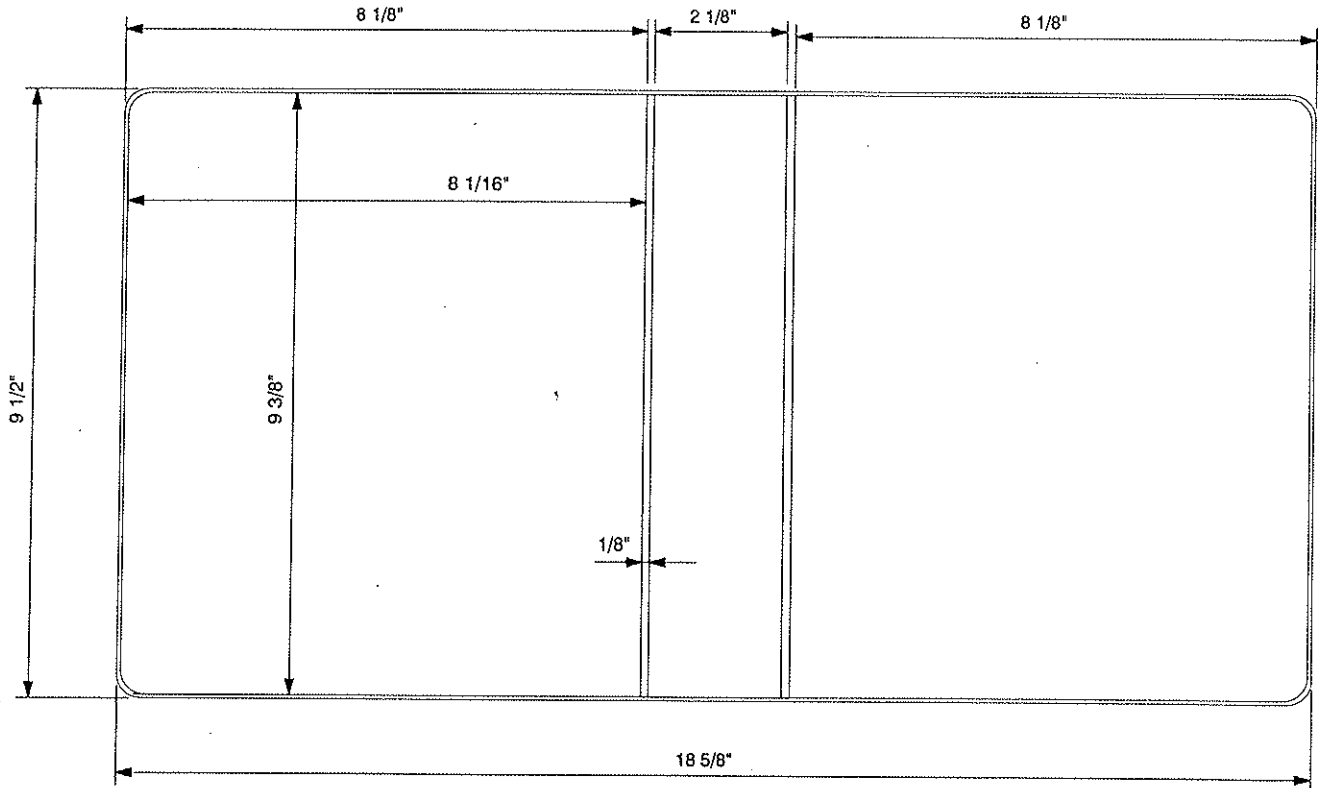

MATERIAL SPECS		GAUGE PCS.		MATERIAL SPECS		GAUGE PCS.	
COVER MAT.	10 1/4 X 19 3/8		1	LINING MAT.	10 1/4 X 19 3/8		1
COVER MAT.				LINING MAT.			
DIE CUT				HORZ. PKT.	4 7/8 X 19 3/8		1
COL				VERT. PKT.			
LABEL HOLDER				DIE CUT			
GUSSET				REINF.			

BOARD SPECS		GAUGE PCS.		BOARD SPECS		GAUGE PCS.	
F.C. BOARD	9 5/16 X 8	120	1	F.C. BOARD			
B.B. BOARD	9 5/16 X 2 1/32	120	1	B.B. BOARD			
B.C. BOARD	9 5/16 X 8	120	1	B.C. BOARD			
FLAP BD.				DIE CUT			
BOARD				DIE CUT			

DIE #	6600	METAL	2" HOC	RADIUS	3/8"
ORDER #	181358	CUSTOMER	AMERICAN SPECIALTY	TEAR SEAL	.012
SHEET SIZE	OAS 9 X 8.25	STYLE CASE	VINYL RING BINDER	BAR SEAL	48-3
CAP.	2"	DUE DATE	11-23-98	COMPLETED	
LOCATION	8-1-2	QUANTITY	500	DATE	11-17-98

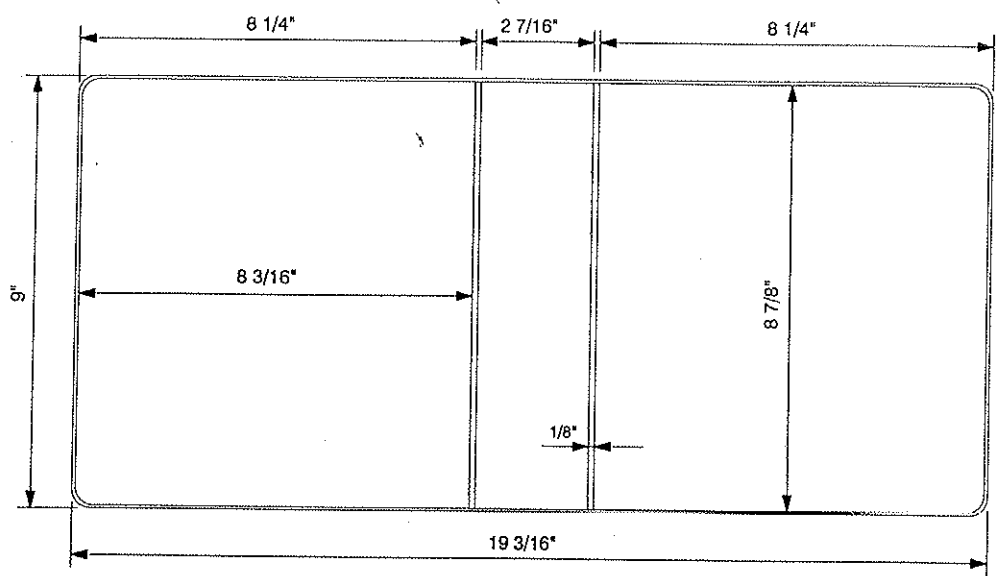

MATERIAL SPECS		GAUGE	PCS.	MATERIAL SPECS	GAUGE	PCS.	
COVER MAT.	9 3/4 X 20		1	LINING MAT.	9 3/4 X 20	1	
COVER MAT.				LINING MAT.			
DIE CUT				HORZ. PKT.	4 7/8 X 20	1	
COL				VERT. PKT.			
LABEL HOLDER				DIE CUT			
GUSSET				REINF.			
BOARD SPECS		GAUGE	PCS.	BOARD SPECS		GAUGE	PCS.
F.C. BOARD	8 13/16 X 8 1/8	120	1	F.C. BOARD	5/16" R. CORNERS		
B.B. BOARD	8 13/16 X 2 11/32	120	1	B.B. BOARD			
B.C. BOARD	8 13/16 X 8 1/8	120	1	B.C. BOARD			
FLAP BD.				DIE CUT			
BOARD				DIE CUT			

DIE #	6785 1up	METAL	LOC PRONG METAL	RADIUS	1/4"
ORDER #	280891	CUSTOMER	AT-A-GLANCE GROUP	TEAR SEAL	BLIND
SHEET SIZE	8.25 X 6.25	STYLE CASE	VINYL RING BINDER	BAR SEAL	FLAT
CAP.	1"	DUE DATE	3-20-99	COMPLETED	
LOCATION		QUANTITY	1	DATE	10-20-99

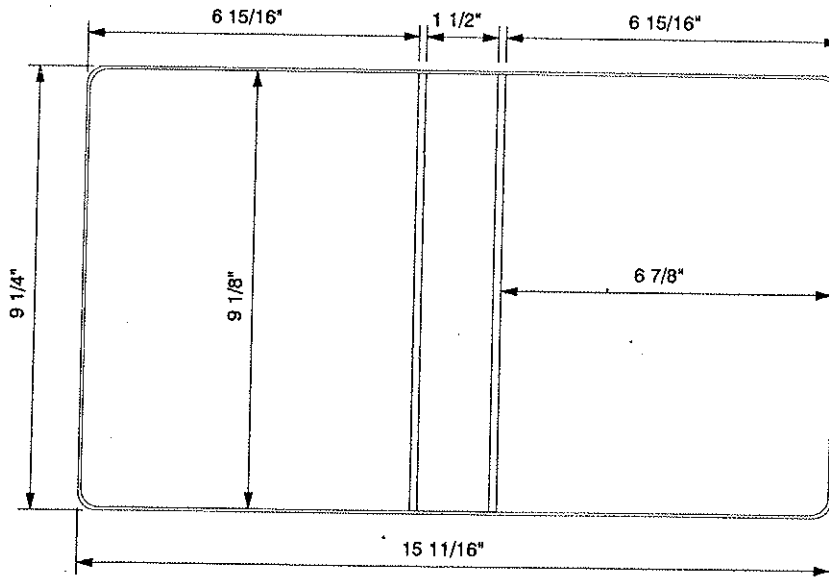

MATERIAL SPECS		GAUGE	PCS.	MATERIAL SPECS		GAUGE	PCS.
COVER MAT.	10 X 16 11/16		1	LINING MAT.	10 X 16 11/16		1
PICTORIAL				LINING MAT.			
LABEL HOLDER				HORZ. PKT.			
COL				HORZ. PKT.			
EX COL NO TRIM				ONE SIDED			
EX COL				ONE SIDED			

NORMAL 1/16" TOL		5/16" R. CORNERS	PCS.	BOARD TOL. (3/32")	5/16" R. CORNERS	PCS.
F.C. BOARD	9 1/16 X 6 13/16		1	F.C. BOARD		
B.B. BOARD	9 1/16 X 1 13/32		1	B.B. BOARD		
B.C. BOARD	9 1/16 X 6 13/16		1	B.C. BOARD		
FLAP BD.				DIE CUT		

DIE #	6938	METAL	ANGLE D	RADIUS	3/8"
ORDER #	341905	CUSTOMER	FISHER ROSEMOUNT	TEAR SEAL	IMAGESOURCE BLIND EDGE
SHEET SIZE	9 x 7 1/2	STYLE CASE	VINYL IMAGESOURCE DIE	BAR SEAL	IMAGESOURCE EVERLIFE
CAP.	1 1/2"	DUE DATE	6-19-00	COMPLETED	
LOCATION		QUANTITY	325	DATE	6-9-00

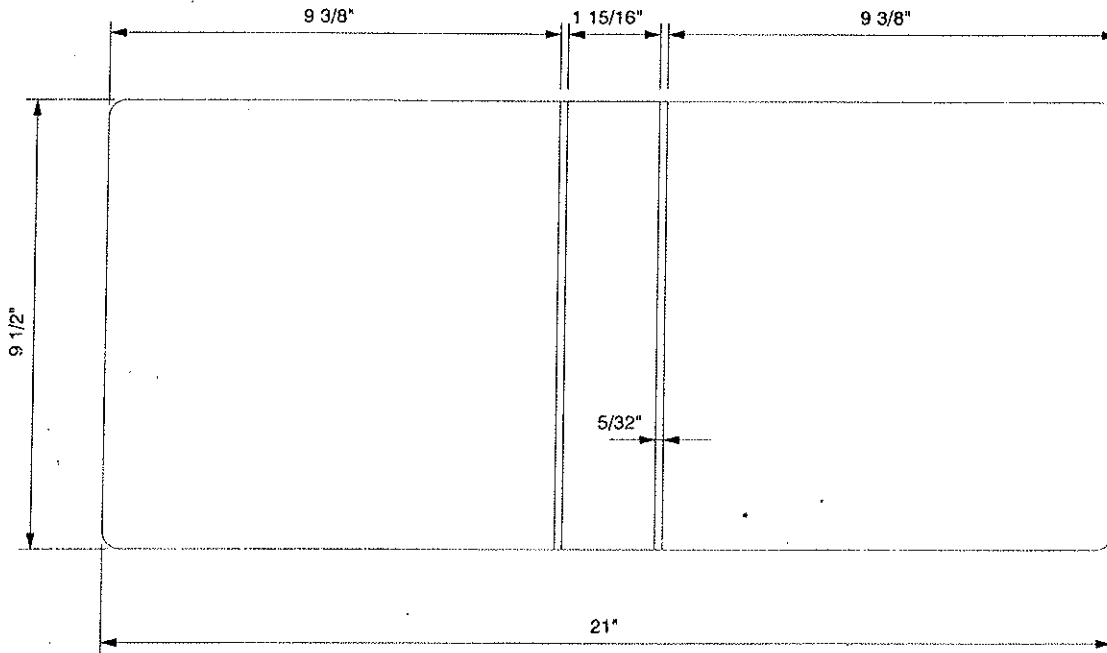

MATERIAL SPECS		GAUGE	PCS.	MATERIAL SPECS		GAUGE	PCS.
COVER MAT.	10 1/4 X 21 3/4		1	LINING MAT.	10 1/4 X 21 3/4		1
COVER MAT.				LINING MAT.			
DIE CUT				HORZ. PKT.	3 7/8 X 9 7/8		1
COL				VERT. PKT.			
LABEL HOLDER	6 3/8 X 3		1	DIE CUT			
BUSSET				REINF.			
BOARD SPECS	5/16" R. CORNERS	GAUGE	PCS.	BOARD SPECS	5/16" R. CORNERS	GAUGE	PCS.
F.C. BOARD	9 7/16 X 9 5/16	100	1	F.C. BOARD			
B.B. BOARD	9 7/16 X 1 27/32	100	1	B.B. BOARD			
B.C. BOARD	9 7/16 X 9 5/16	100	1	B.C. BOARD			
FLAP BD.				DIE CUT			
BOARD				DIE CUT			

DIE #	7135	METAL	STR D.	RADIUS	1/4"
ORDER #	445042	CUSTOMER	GILMORE GLOBAL	TEAR SEAL	.010
SHEET SIZE	9 X 7 1/2	STYLE CASE	VRB	BAR SEAL	48-4
CAP.	2 1/2"	DUE DATE	8-13-01	COMPLETED	
LOCATION		QUANTITY	500	DATE	7-31-01

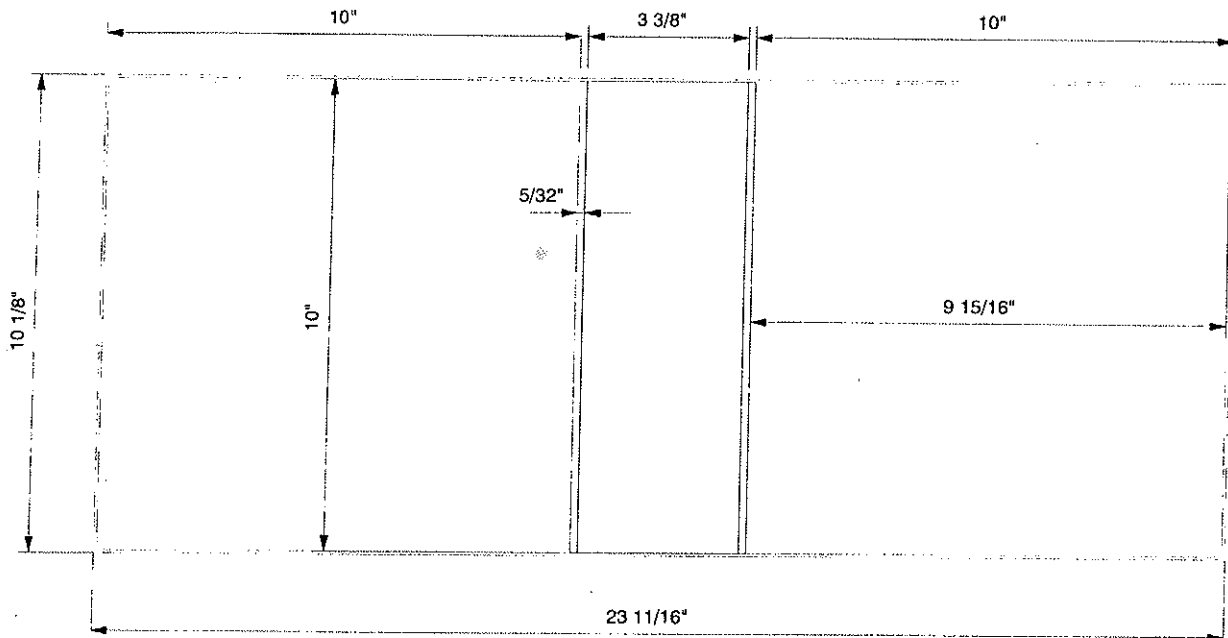

MATERIAL SPECS		GAUGE	PCS.	MATERIAL SPECS		GAUGE	PCS.
COVER MAT.	10 7/8 X 24 1/2		1	LINING MAT.	10 7/8 X 24 1/2		1
COVER MAT.				LINING MAT.			
DIE CUT				HORZ. PKT.	5 3/8 X 10 1/2		1
COL	10 3/8 x 14		1	VERT. PKT.			
LABEL HOLDER				DIE CUT			
GUSSET				REINF.			
BOARD SPECS		GAUGE	PCS.	BOARD SPECS		GAUGE	PCS.
F.C. BOARD	9 15/16 X 9 7/8	120	1	F.C. BOARD	5/16" R. CORNERS		
B.B. BOARD	9 15/16 X 3 9/32	120	1	B.B. BOARD			
B.C. BOARD	9 15/16 X 9 7/8	120	1	B.C. BOARD			
FLAP BD.				DIE CUT			
BOARD				DIE CUT			

DIE #	7136	METAL	STR D.	RADIUS	1/4"
ORDER #	444710	CUSTOMER	GILMORE GLOBAL	TEAR SEAL	.010
SHEET SIZE	9 X 7 1/2	STYLE CASE	VRB	BAR SEAL	48-4
CAP.	2"	DUE DATE	8-13-01	COMPLETED	
LOCATION		QUANTITY	500	DATE	7-31-01

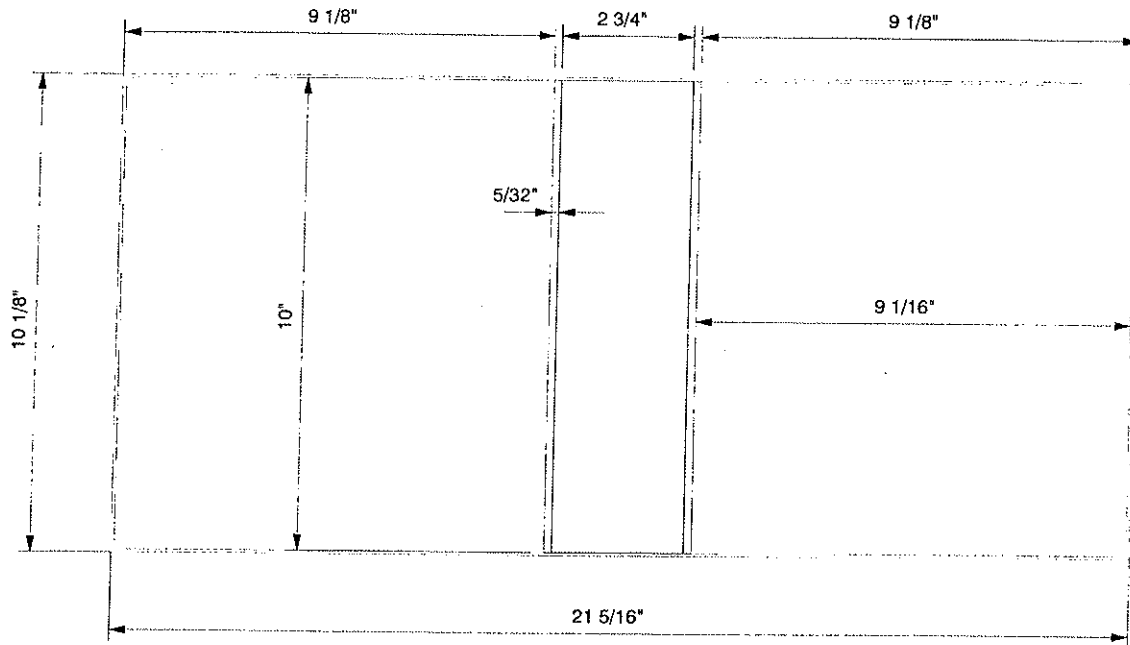

MATERIAL SPECS		GAUGE	PCS.	MATERIAL SPECS		GAUGE	PCS.
COVER MAT.	10 7/8 X 22 1/8		1	LINING MAT.	10 7/8 X 22 1/8		1
COVER MAT.				LINING MAT.			
COL	10 3/8 x 12 1/2		1	HORZ. PKT.	5 3/8 X 9 5/8		1
COL				VERT. PKT.			
LABEL HOLDER				DIE CUT			
GUSSET				REINF.			
BOARD SPECS		GAUGE	PCS.	BOARD SPECS		GAUGE	PCS.
F.C. BOARD	9 15/16 X 9	100	1	F.C. BOARD	5/16" R. CORNERS		
B.B. BOARD	9 15/16 X 2 21/32	100	1	B.B. BOARD			
B.C. BOARD	9 15/16 X 9	100	1	B.C. BOARD			
FLAP BD.				DIE CUT			
BOARD				DIE CUT			

DIE #	7481-R	METAL	LOC	RADIUS	3/8"
ORDER #	569459	CUSTOMER	GINY'S PRINTING	TEAR SEAL	.014
SHEET SIZE	8 5/8 X 7 1/4	STYLE CASE	VINYL BINDER	BAR SEAL	48-3
CAP.	1"	DUE DATE	8-4-03	COMPLETED	
LOCATION		QUANTITY	150	DATE	7-29-03

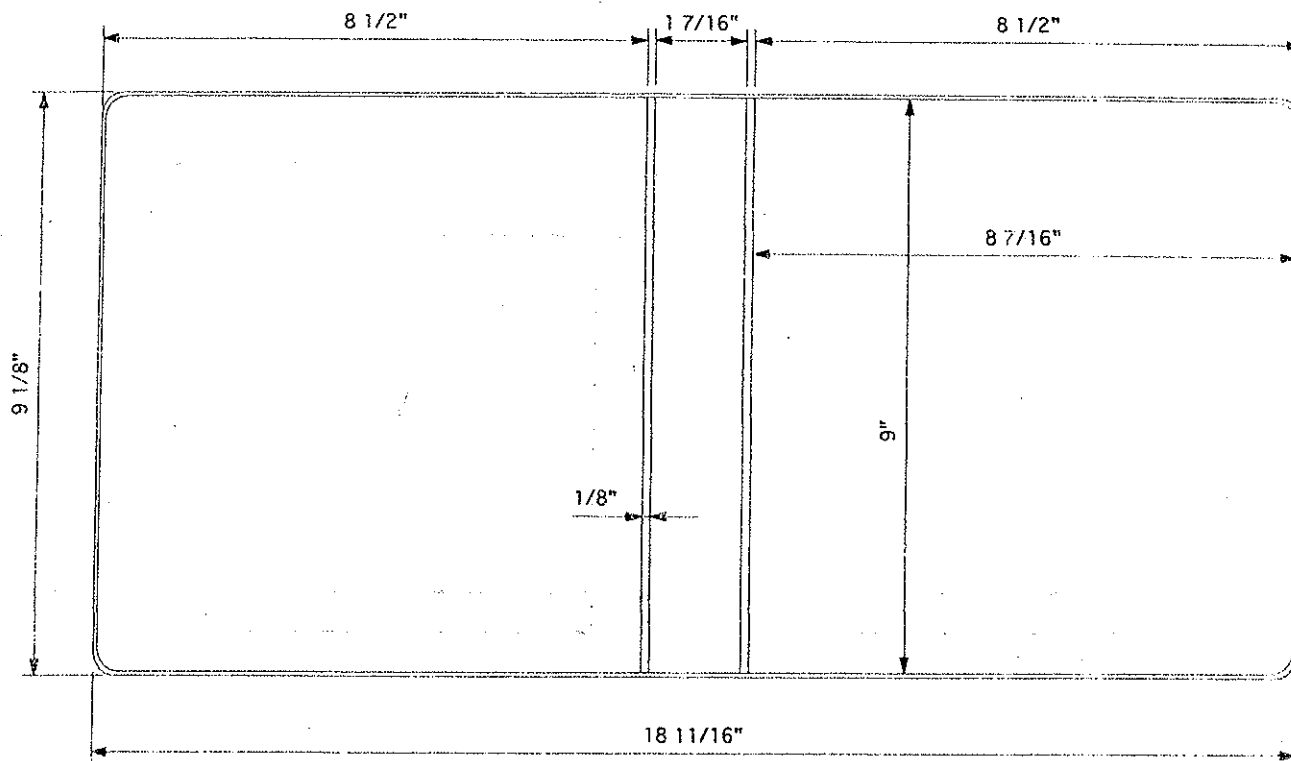

MATERIAL SPECS		GAUGE	PCS.	MATERIAL SPECS	GAUGE	PCS.
COVER MAT.	9 7/8 X 19 1/2		1	LINING MAT.	9 7/8 X 19 1/2	1
COVER MAT.				LINING MAT.		
DIE CUT				HORZ. PKT.		
COL	9 1/4 X 19 1/2		1	VERT. PKT.		
LABEL HOLDER				DIE CUT		
GUSSET				REINF.		
BOARD SPECS		GAUGE	PCS.	BOARD SPECS	GAUGE	PCS.
F.C. BOARD	8 15/16 X 8 3/8		100	F.C. BOARD		
B.B. BOARD	8 15/16 X 1 11/32		100	B.B. BOARD		
B.C. BOARD	8 15/16 X 8 3/8		100	B.C. BOARD		
FLAP BD.				DIE CUT		
BOARD	9 25/32 X 1 5/16		35	DIE CUT		