

Stock

DIE # 860	STYLE CASE V R B	LOCATION
SHEET SIZE 8 1/2 x 6 +	CAP. 1/2	ORDER NO.
CUSTOMER		DUE DATE

QUANTITY	
DATE	

RADIUS 3/8"	
COMPLETED	

TEAR SEAL .014 - 1/16"	
BAR SEAL 102 - 3/32"	

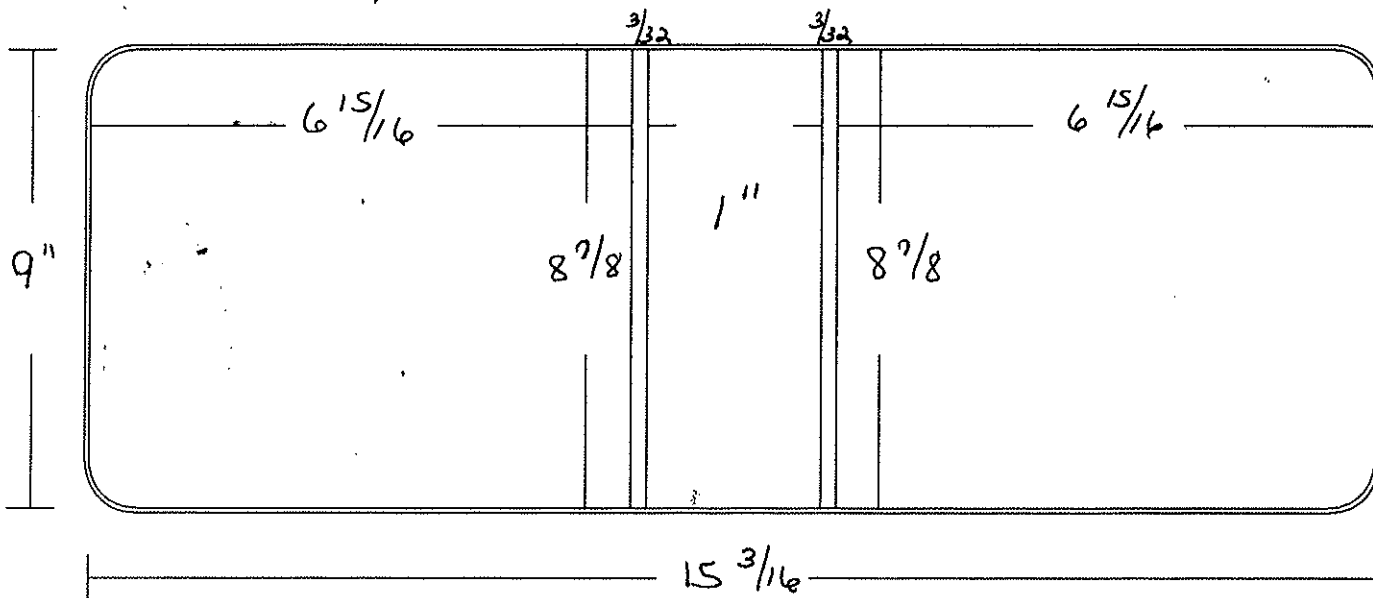

MATERIAL

	CODE	GA	PCS		CODE	GA	PCS
COVER MATL	9 3/4 X 16		1	LINING	9 3/4 X 16		1
COVER MATL	X			LINING	X		
VERT PKT	X			HORZ PKT	1-sided 4 3/8 X 7 1/2		1
VERT PKT	X			HORZ PKT	Full 4 3/8 X 16		1
CARD HOLDER	X			DIAGONAL PKT	X		
COL	9 1/8 X 16		1	LABEL HOLDER	X		
EX. COL	9 1/8 X 9 1/4		1	GUSSETT	X		
No Trim Excl	9 1/8 X 8 1/32		1	REINF.	X		
	X				X		

PRINTS

FRONT COVER	X	BACK BONE	X	BACK COVER	X
-------------	---	-----------	---	------------	---

BOARDS

	CODE	PT	PCS		CODE	PT	PCS
F.C. BOARD	Pro-cut 033990 8 13/16 X 6 7/8	100	1	F.C. BOARD	860-B Padded Bd. Dic Cutting FC Panel Only 2 up		
B.B. BOARD	8 13/16 X 29/32	100	1	B.B. BOARD	9 13/16 X 15 1/4		
B.C. BOARD	8 13/16 X 6 7/8	100	1	B.C. BOARD	X		
B. UP STRIP	X			860-C Padded FC-BB-BC			
	X				11 3/16 X 15 3/16		

DIE #	862	METAL		RADIUS	1/4"
ORDER #		CUSTOMER	CAROLINA STEEL	TEAR SEAL	.012
SHEET SIZE	8 1/2 X 6 1/2	STYLE CASE	VINYL RING BINDER	BAR SEAL	178
CAP.	1"	DUE DATE		COMPLETED	
LOCATION	H-11-8	QUANTITY		DATE	9-23-96

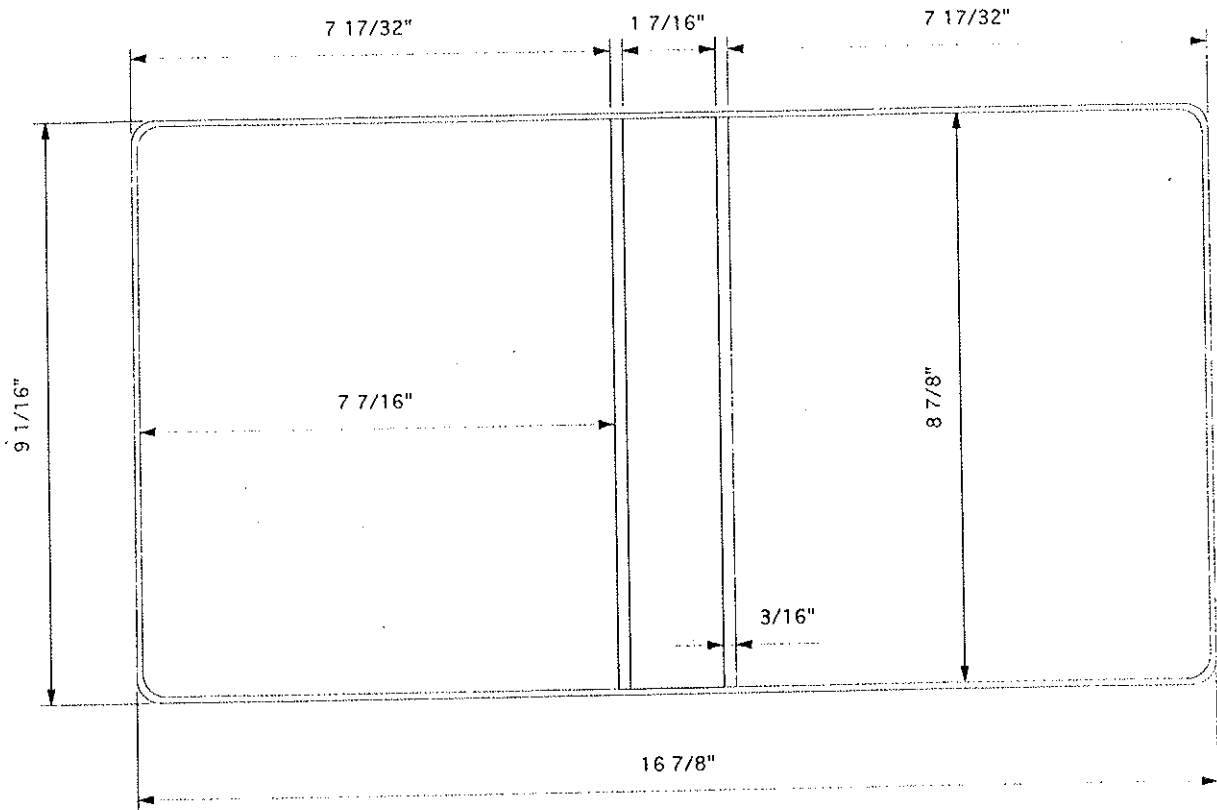

MATERIAL SPECS		GAUGE		PCS.		MATERIAL SPECS		GAUGE	
COVER MAT.	9 13/16 X 17 5/8			1		LINING MAT.	9 13/16 X 17 5/8		
COVER MAT.						LINING MAT.			
DIE CUT						HORZ. PKT.			
COL						VERT. PKT.			
LABEL HOLDER						DIE CUT			
GUSSET						REINF.			
BOARD SPECS		GAUGE		PCS.		BOARD SPECS		GAUGE	
F.C. BOARD	8 13/16 X 7 3/8	100	1			F.C. BOARD	8 25/32 X 7 11/32	120	
B.B. BOARD	8 13/16 X 1 11/32	100	1			B.B. BOARD	8 25/32 X 1 11/32	120	
B.C. BOARD	8 13/16 X 7 3/8	100	1			B.C. BOARD	8 25/32 X 7 11/32	120	
FLAP BD.						DIE CUT			
BOARD						DIE CUT			

Stoch

DIE #	947-R	METAL		RADIUS	3/8
ORDER #		CUSTOMER		TEAR SEAL	
SHEET SIZE	8 1/2 X 6	STYLE CASE	VINYL RING BINDER	BAR SEAL	48-4
CAP.	3/4"	DUE DATE		COMPLETED	
LOCATION	21 G3 1007	QUANTITY		DATE	4-12-96

REVISION - 4-12-96 - SPINE WAS INCREASED FROM 1 1/16" TO 1 1/8". ALSO 3/32" BARS WERE CHANGED TO 5/32".

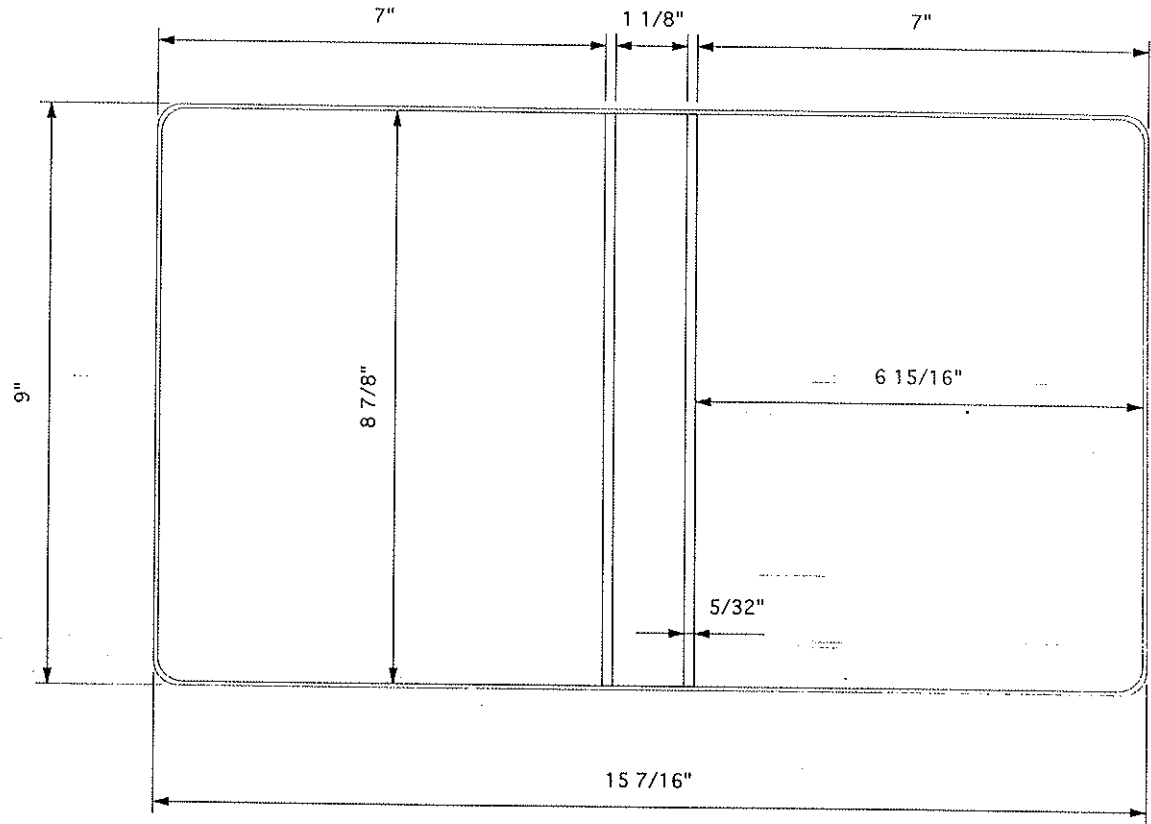

MATERIAL SPECS		GAUGE		PCS.		MATERIAL SPECS		GAUGE		PCS.	
COVER MAT.	9 3/4 X 16 1/4			1		LINING MAT.	9 3/4 X 16 1/4			1	
COVER MAT.						LINING MAT.					
DIE CUT						HORZ. PKT.	4 3/8 X 7 1/2	ONE SIDE			1
COL	9 1/8 X 16 1/4			1		HORZ. PKT.	4 3/8 X 16 1/4	FULL			1
EX COL	9 1/8 X 9 1/2			1		DIE CUT					
NO TRIM EX COL	9 1/8 X 9 1/16			1		REINF.					
BOARD SPECS		GAUGE		PCS.		BOARD SPECS		GAUGE		PCS.	
F.C. BOARD	8 13/16 X 6 7/8	100		1		F.C. BOARD					
B.B. BOARD	8 13/16 X 1 1/32	100		1		B.B. BOARD					
B.C. BOARD	8 13/16 X 6 7/8	100		1		B.C. BOARD					
FLAP BD.						DIE CUT	11 5/16 X 15 1/4				1
BOARD						DIE CUT					

Stuck LOC & STD NB

DIE # 1037	STYLE CASE VRB	LOCATION
SHEET SIZE 8 1/2 X 6 +	CAP. 1"	ORDER NO.
CUSTOMER	DUE DATE	

QUANTITY	RADIUS 3/8"	TEAR SEAL
DATE	COMPLETED	BAR SEAL

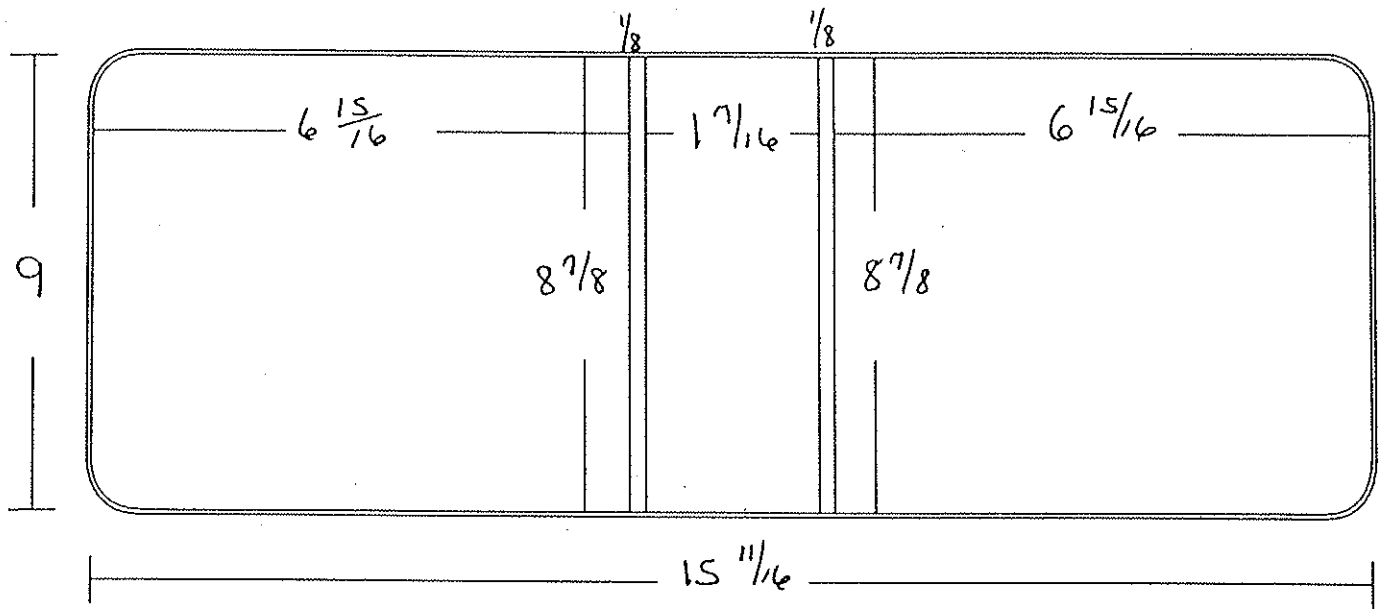

MATERIAL

	CODE	GA	PCS		CODE	GA	PCS
COVER MATL		9 3/4 X 16 1/2	1	LINING		9 3/4 X 16 1/2	1
COVER MATL	Padded	10 X 16 3/4	1	LINING		X	
VERT PKT		X		HORZ PKT	1-sided	4 3/8 X 7 1/2	1
VERT PKT		X		HORZ PKT	Full	4 3/8 X 16 1/2	1
CARD HOLDER		X		DIAGONAL PKT		X	
COL		9 1/8 X 16 1/2	1	LABEL HOLDER		X	
EX. COL		9 1/8 X 9 3/4	1	GUSSETT		X	
No Trim F. Col		9 1/8 X 9 1/4		REINF.		X	
		X				X	

PRINTS

FRONT COVER	X	BACK BONE	X	BACK COVER	X
-------------	---	-----------	---	------------	---

BOARDS

	CODE	PT	PCS		CODE	PT	PCS
F.C. BOARD	Pre-cut 033390	8 13/16 X 6 7/8	100	1	F.C. BOARD	FC BB	
B.B. BOARD	Pre-cut 035992	8 13/16 X 1 1/32	100	1	B.B. BOARD	B.C.	
B.C. BOARD		8 13/16 X 6 7/8	100	1	B.C. BOARD		X
B. UP STRIP		X				X	
		X		1		X	

Product Code E.O.

Style Case Ring Binder

Sheet Size 8 1/2 X 6 3/8 Cap. 1 1/2 Die No. 3319 Order No. 948150 Plate

Customer

Computone systems

4-2-85

Metal
Total Vinyl <u>.024</u>
Quantity <u>1000</u>
Date
Type Corners <u>RD</u>
Radius <u>1/4</u>
Completed

	Gauge	Thick
Tear Seal	<u>.012</u>	<u>3/32</u>
Bar Seal	<u>178</u>	<u>3/16</u>
Bar Seal		

	No. of Feet
Tear Seal	
Bar Seal	
Bar Seal	

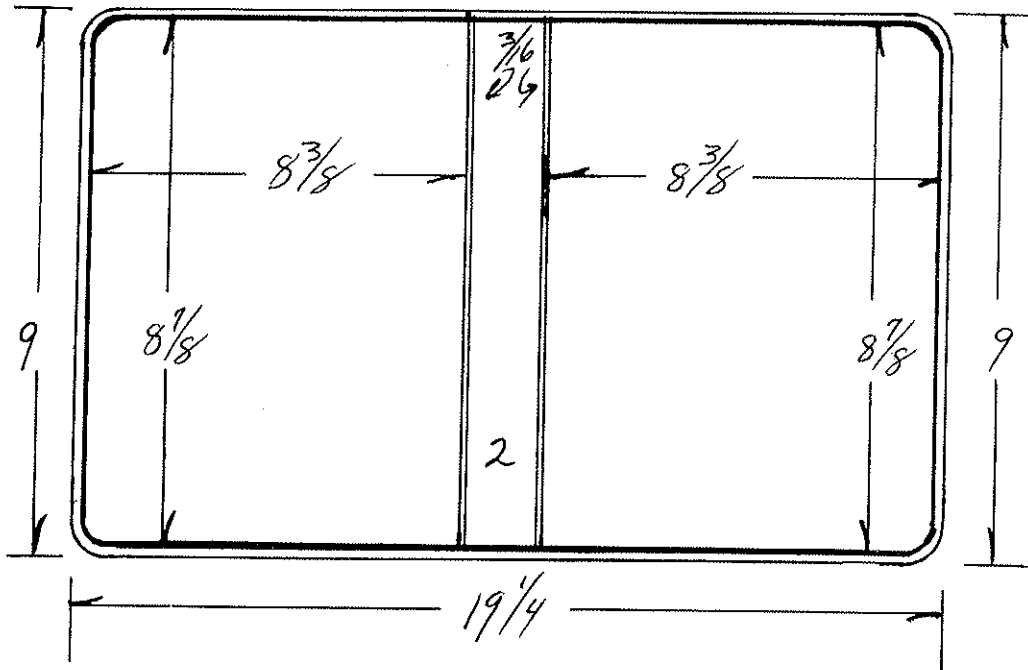

Code	Ga.	#	Cutting Specs		Code	Ga.	#	Cutting Specs	
			Size	Out				Size	Out
Cover Mat.			<u>9 5/8 X</u>	<u>20</u>	Lining Mat.			<u>9 5/8 X</u>	<u>20</u>
Cover Mat.			X		Lining Mat.			X	
Vert. Pckt.			X		Horz. Pckt.			X	
Vert. Pckt.			X		Horz. Pckt.			X	
Pocket			X		Pocket			X	
Label Holder			<u>4 13/16 X</u>	<u>2 3/8</u>	Card Holder			X	
Material			X		Material			X	
Material			X		Material			X	
Material			X		Material			X	
F.C. Board			<u>8 25/32 X</u>	<u>8 9/32</u>	B.C. Board			<u>8 25/32 X</u>	<u>8 9/32</u>
B.C. Board			<u>8 13/16 X</u>	<u>8 5/16</u>	B.B. Board			<u>8 25/32 X</u>	<u>1 23/32</u>
Center Board	FC		<u>8 13/16 X</u>	<u>8 5/16</u>	Board	BB		<u>8 13/16 X</u>	<u>1 29/32</u>
Board			X		Strip			X	
Cover Pad			X		Strip			X	
					B.B. Pad			X	

Product Code

Style Case Ring Binder 1/2" Loc

Sheet Size 8 1/2 X 6 5/8 Cap. 1/2

Die No. 3707

Order No. 954025 Plate

Customer

Pie Nationwide

Metal
Total Vinyl
Quantity
Date
Type Corners
Radius
Completed

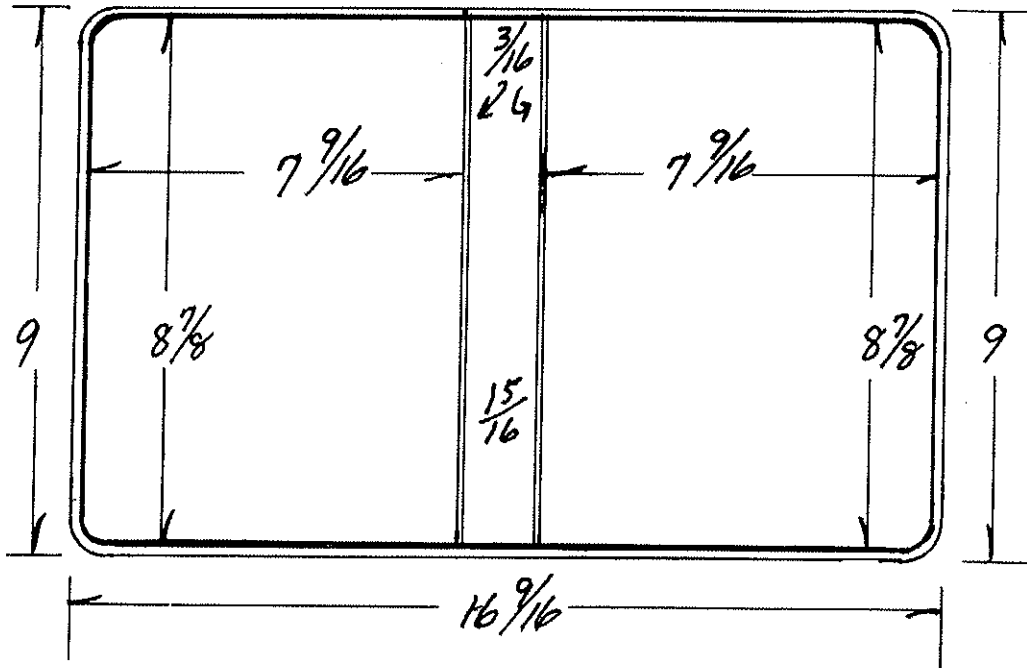

	Gauge	Thick
Tear Seal	.016	3/32
Bar Seal	.178	3/16
Bar Seal		

	No. of Feet
Tear Seal	
Bar Seal	
Bar Seal	

Code	Ga.	Pcs	Cutting Specs		Code	Ga.	Pcs	Cutting Specs	
			Size	Out				Size	Out
Cover Mat.			9 5/8 X 17 5/16	1	Lining Mat.			9 5/8 X 17 5/16	1
Cover Mat			X		Lining Mat.			X	
Vert. Pckt.			X		Horz. Pckt.			X	
Vert. Pckt.			X		Horz. Pckt.			X	
Pocket			X		Pocket			X	
Label Holder			X		Card Holder			X	
Material			X		Material			X	
Material			X		Material			X	
Material			X		Material			X	
F.C. Board			8 25/32 X 7 15/32	1	B.C. Board			8 25/32 X 7 15/32	1
B.C. Board			X		B.B. Board			8 25/32 X 7 27/32	1
Center Board			X		Board			X	
Board			X		Strip			X	
Cover Pad			X		Strip			X	
					B.B. Pad			X	

Product Code

Style Case *CVRB W/ slip case*

Sheet Size $8\frac{1}{2} \times 6\frac{5}{8}$ Cap. $1\frac{1}{2}$ Die No. 3760 Order No. 954737 Plate # 32

Customer *Harris Corp*

Metal
Total Vinyl
Quantity <i>400</i>
Date
Type Corners <i>Rd.</i>
Radius $\frac{1}{4}$
Completed

	Gauge	Thick
Tear Seal	<i>16</i>	<i>3/32</i>
Bar Seal	<i>1/8</i>	<i>72</i>
Bar Seal		

	No. of Feet
Tear Seal	
Bar Seal	
Bar Seal	

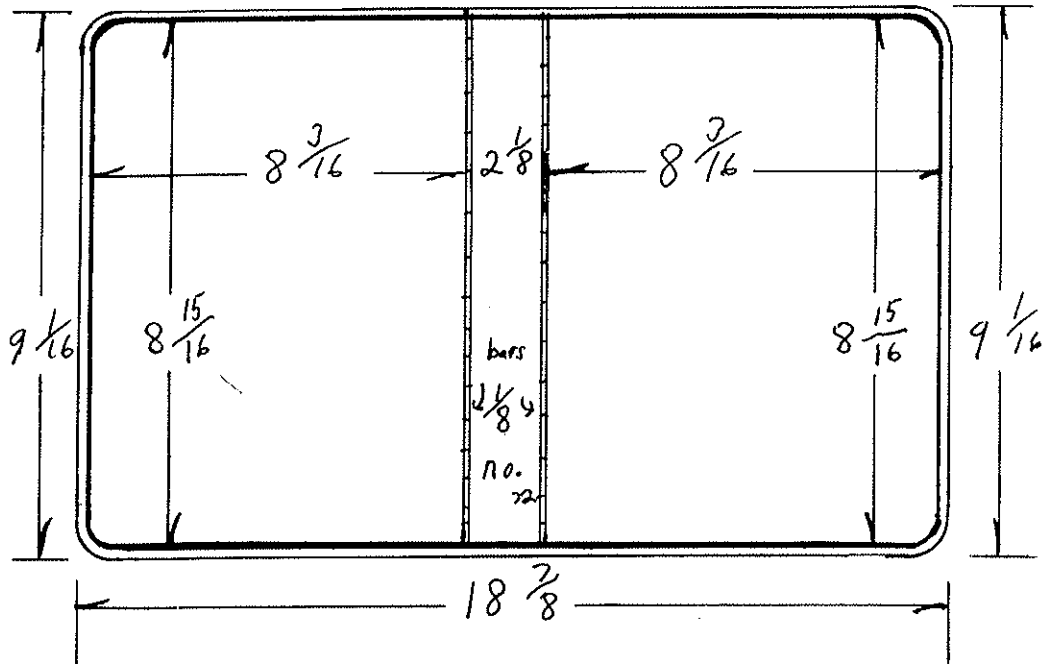

To be use with
Die no. 3759

Code		Cutting Specs				Code		Cutting Specs			
		Ga.	# PCS	Size	Out			Ga.	Pcs.	Size	Out
Cover Mat.	$9\frac{1}{16} \times 19\frac{1}{2}$		1			Lining Mat.	$9\frac{1}{16} \times 19\frac{1}{2}$		1		
Cover Mat.	X					Lining Mat.	X				
Vert. Pckt.	X					Horz. Pckt.	$6\frac{1}{8} \times 10\frac{3}{8}$				
Vert. Pckt.	X					Horz. Pckt.	X				
Pocket	X					Pocket	X				
Label Holder	X					Card Holder	<i>FULL</i> X				
Material	X					Material	<i>C.O.L.</i> $9\frac{3}{16} \times 19\frac{5}{8}$	8	1		
Material	X					Material	X				
Material	X					Material	X				
F.C. Board	$8\frac{27}{32} \times 8\frac{3}{32}$	120	1			B.C. Board	$8\frac{27}{32} \times 8\frac{3}{32}$	120	1		
B.C. Board	$8\frac{7}{8} \times 8\frac{1}{8}$	100	2			B.B. Board	$8\frac{27}{32} \times 2\frac{1}{32}$	120	1		
Center Board	$8\frac{7}{8} \times 2\frac{1}{32}$	100	1			Board	X				
Board	X					Strip	X				
<i>Padded Bd.</i>	<i>Die #3760A</i>					Strip	X				
<i>FC-BB-BC</i>	$12\frac{3}{8} \times 17\frac{3}{4}$					B.B. Pad	X				

Product Code AS Sample

Style Case Ring Binder

Sheet Size 8 1/2 X 6 Cap. 2 Die No. 3777 Order No. 954938 Plate

Customer

Zone VI Studio, Inc.

Metal
Total Vinyl .030
Quantity 1,000
Date 4-10-87
Type Corners RD
Radius 1/4
Completed

	Gauge	Thick
Tear Seal	.016	3/32
Bar Seal	102	3/32
Bar Seal		

	No. of Feet
Tear Seal	
Bar Seal	
Bar Seal	

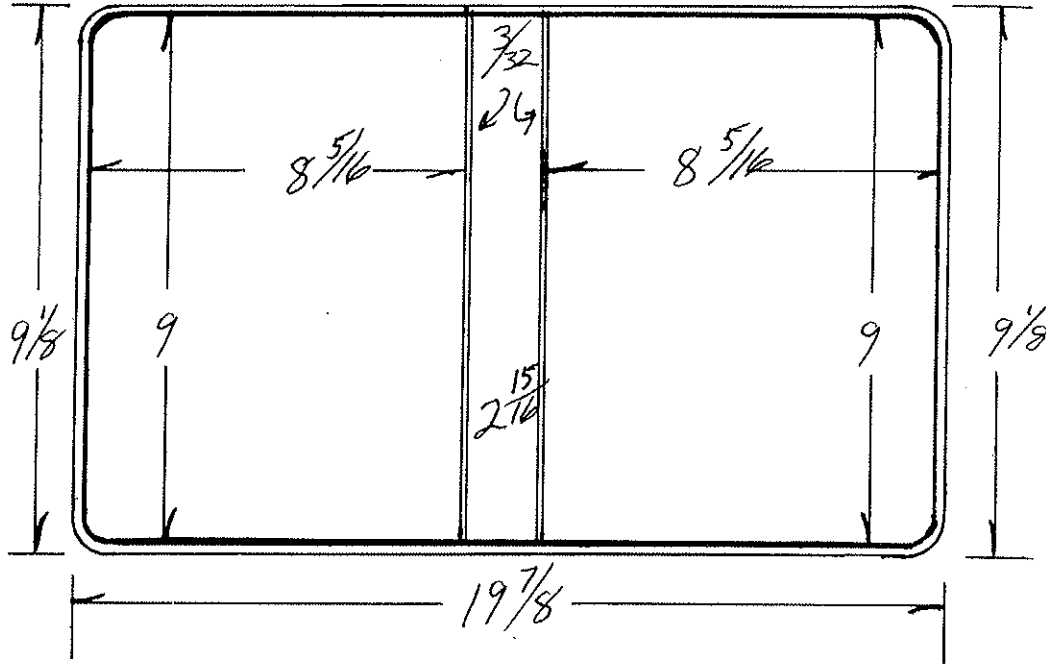

Code	Ga.	# PCS	Cutting Specs		Code	Ga.	# Pcs.	Cutting Specs	
			Size	Out				Size	Out
Cover Mat.		1	9 3/4 X 20 5/8		Lining Mat.		1	9 3/4 X 20 5/8	
Cover Mat			X		Lining Mat.			X	
Vert. Pckt.			X		Horz. Pckt.			X	
Vert. Pckt.			X		Horz. Pckt.			X	
Pocket			X		Pocket			X	
Label Holder			X		Card Hlder			X	
Material			X		Material			X	
Material			X		Material			X	
Material			X		Material			X	
F.C. Board		120	1	8 29/32 X 8 7/32	B.C. Board		120	1	8 29/32 X 8 7/32
B.C. Board		100	2	8 15/16 X 8 1/4	B.B. Board		120	1	8 29/32 X 2 7/32
Center Board		100	1	8 15/16 X 2 27/32	Board			X	
Board				X	Strip			X	
Cover Pad				X	Strip			X	
					B.B. Pad			X	

D Ring

DIE # 3784	STYLE CASE VRB w/ slipcase Die # 4018	LOCATION
SHEET SIZE 8 1/2 x 6 5/8 +	CAP. 1	ORDER NO.
CUSTOMER		DUE DATE

QUANTITY	
DATE	

RADIUS	1/4
COMPLETED	

TEAR SEAL	
BAR SEAL	

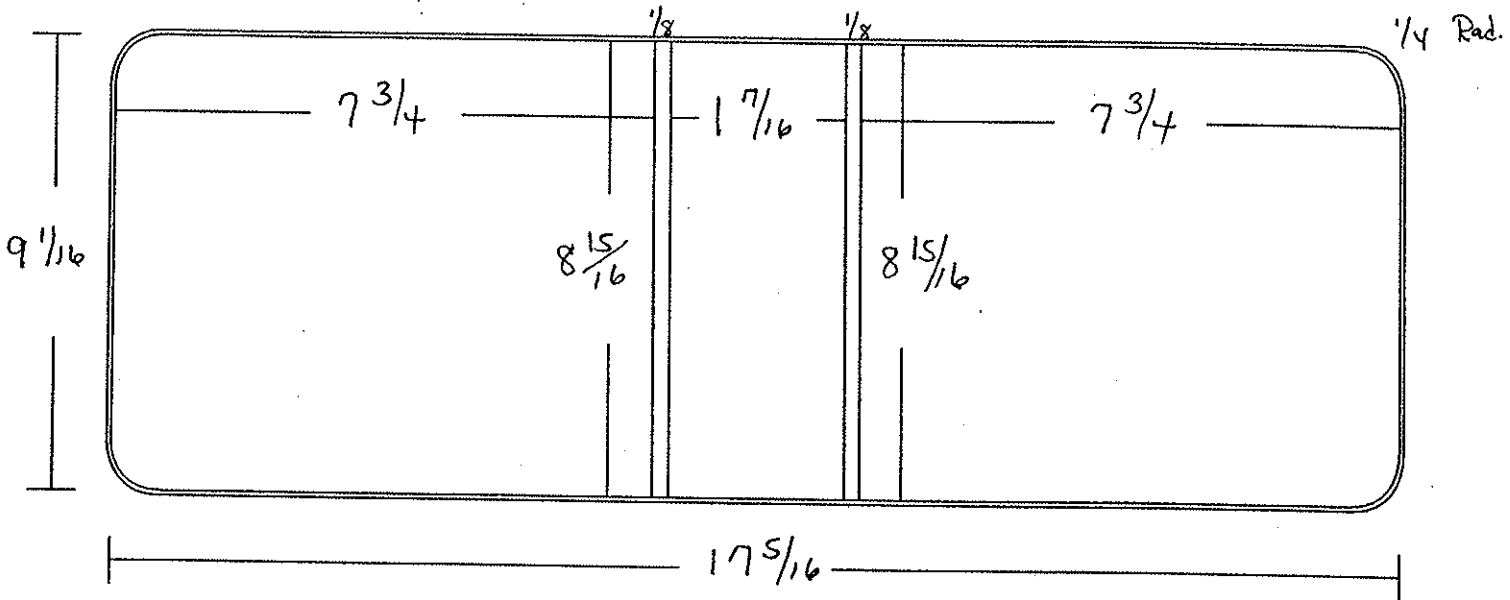

MATERIAL

	CODE		GA	PCS		CODE		GA	PCS
COVER MATL		9 3/4 X 18 1/16		1	LINING		9 3/4 X 18 1/16		1
COVER MATL		X			LINING		X		
VERT PKT		X			HORZ PKT		5 3/8 X 8 1/4		1
VERT PKT		X			HORZ PKT		5 3/8 X 18 1/16		1
CARD HOLDER		X			DIAGONAL PKT		4 3/8 X 8 1/4		1
COL		9 3/16 X 18 1/16		1	LABEL HOLDER	PKT.	4 3/8 X 18 1/16		1
EX. COL		D-Ring Only			GUSSETT		X		
Cutting Die	COL	10 1/4 X 19 1/8			REINF.		X		
3784-B Die Cut		X					X		

PRINTS

FRONT COVER	X	BACK BONE	X	BACK COVER	X
-------------	---	-----------	---	------------	---

BOARDS

	CODE		PT	PCS		CODE		PT	PCS
033998		8 7/8 X 7 11/16		1	F.C. BOARD		X		
035991		8 7/8 X 1 3/8		1	B.B. BOARD		X		
B.C. BOARD		8 7/8 X 7 11/16		1	B.C. BOARD		X		
B. UP STRIP		X					X		
XX		X					X		

Product Code ERSCO Media

Style Case Ring Binder

Sheet Size X

Cap.

Die No. 3812

Order No. 58613

Plate

Customer Sample

Metal	NONE
Total Vinyl	.030
Quantity	1
Date	5/25/87
Type Corners	R/O
Radius	94
Completed	

	Gauge	Thick
Tear Seal	1/6	
Bar Seal	1/8	
Bar Seal		

	No. of Feet
Tear Seal	
Bar Seal	
Bar Seal	

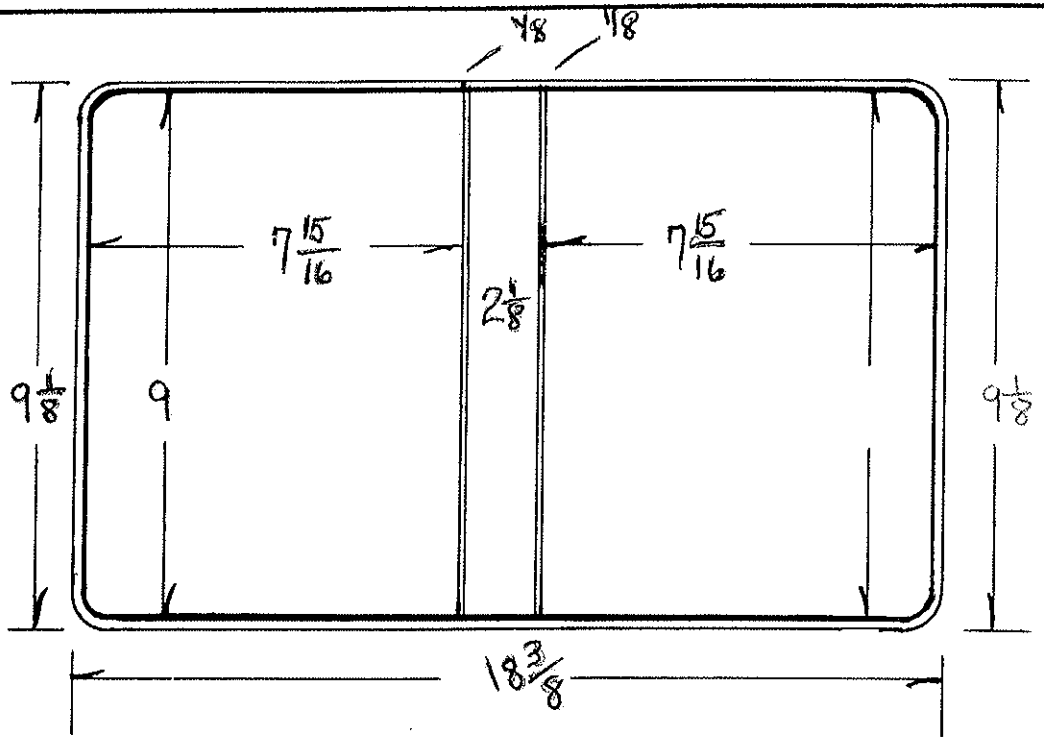

Code	Ga.	# PCS	Cutting Specs.		Code	Ga.	# Pcs.	Cutting Specs.	
			Size	Out				Size	Out
Cover Mat.		1	9 3/4 X	19 1/8	Lining Mat.		1	9 3/4 X	19 1/8
Cover Mat			X		Lining Mat.			X	
Vert. Pckt.			X		Horz. Pckt.			X	
Vert. Pckt.			X		Horz. Pckt.			X	
Pocket			X		Pocket			X	
Label Holder			X		Card Holder			X	
Material			X		Material			X	
Material			X		Material			X	
Material			X		Material			X	
F.C. Board		1	8 29/32 X	7 27/32	B.C. Board			X	
B.C. Board		1	8 29/32 X	7 27/32	B.B. Board			8 29/32 X	7 27/32
Center Board			X		Board			X	
Board			X		Strip			X	
Cover Pad			X		Strip			X	
					B.B. Pad			X	

Stock

DIE # 3911	STYLE CASE V R B	LOCATION
SHEET SIZE 8 1/2 x 6 +	CAP. 1 1/4	ORDER NO.
CUSTOMER	DUE DATE	

QUANTITY		RADIUS	1/4"	TEAR SEAL	
DATE		COMPLETED		BAR SEAL	

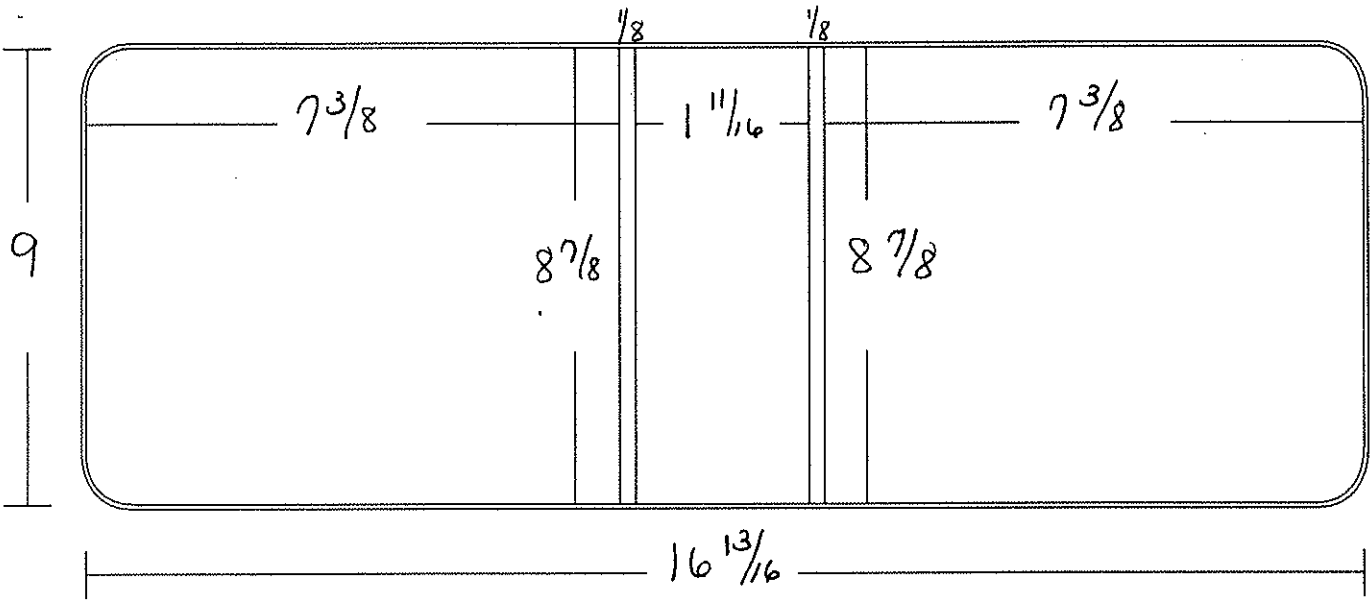

MATERIAL

	CODE	GA	PCS		CODE	GA	PCS
COVER MATL	9 3/4 X 17 5/8		1	LINING	9 3/4 X 17 5/8		1
COVER MATL	X			LINING	X		
VERT PKT	X			HORZ PKT	1-sided 4 3/8 X 7 7/8		1
VERT PKT	X			HORZ PKT	Full 4 3/8 X 17 5/8		1
CARD HOLDER	X			DIAGONAL PKT	X		
COL	9 1/8 X 17 5/8		1	LABEL HOLDER	X		
EX. COL	9 1/8 X 10 3/8		1	GUSSETT	X		
	X			REINF.	X		
	X				X		

PRINTS

FRONT COVER	X	BACK BONE	X	BACK COVER	X
-------------	---	-----------	---	------------	---

BOARDS

	CODE	PT	PCS		CODE	PT	PCS
F.C. BOARD	8 13/16 X 7 5/16	100	1	F.C. BOARD	X		
B.B. BOARD	8 13/16 X 1 19/32	100	1	B.B. BOARD	X		
B.C. BOARD	8 13/16 X 7 5/16	100	1	B.C. BOARD	X		
B. UP STRIP	X				X		
	X				X		

Product Code Special Die, Old Die 1390 NO PER USE FOR COMPANY - U.S. KING Style Case Ring Binder then HOC

Sheet Size 8 1/2 x 6 Cap. 2 1/2 Die No. 3965 Order No. 958142 2 1/4" metal Plate

Customer

Henson - Piedmont Airlines

Metal
Total Vinyl <u>.038</u>
Quantity <u>25</u>
Date <u>2-11-88</u>
Type Corners <u>RO</u>
Radius <u>1/4</u>
Completed

	Gauge	Thick
Tear Seal	<u>.016</u>	<u>3/32</u>
Bar Seal	<u>102</u>	<u>3/32</u>
Bar Seal		

	No. of Feet
Tear Seal	
Bar Seal	
Bar Seal	

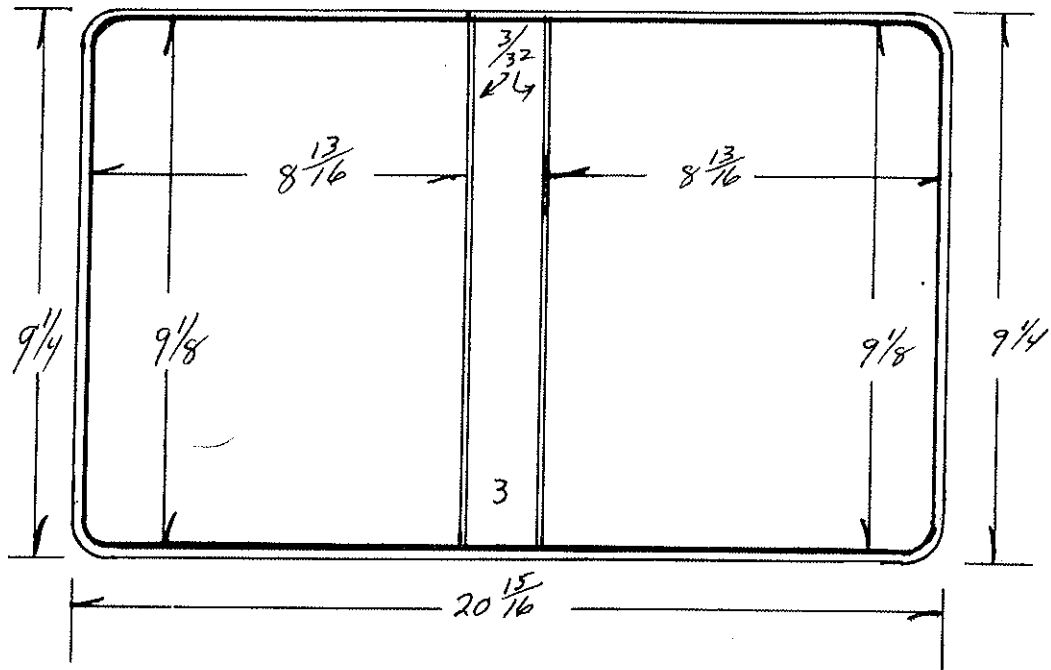

Code	Ga.	PCS	Cutting Specs.		Code	Ga.	Pcs.	Cutting Specs.	
			Size	Out				Size	Out
Cover Mat.			<u>9 1/8</u>	<u>X 21 1/16</u>	Lining Mat.			<u>9 1/8</u>	<u>X 21 1/16</u>
Cover Mat.				X	Lining Mat.				X
Vert. Pckt.				X	Horz. Pckt.	<u>C.O.</u>		<u>9 3/16</u>	<u>X 21 9/16</u>
Vert. Pckt.				X	Horz. Pckt.				X
Pocket				X	Pocket				X
Label Holder				X	Card Holder				X
Material				X	Material				X
Material				X	Material				X
Material				X	Material				X
F.C. Board			<u>9 1/32</u>	<u>X 8 23/32</u>	B.C. Board			<u>9 1/32</u>	<u>X 8 23/32</u>
B.C. Board				X	B.B. Board			<u>9 1/32</u>	<u>X 2 29/32</u>
Center Board				X	Board				X
Board				X	Strip				X
Cover Pad				X	Strip				X
					B.B. Pad				X

Stock

DIE # 3966	STYLE CASE VRB	LOCATION
SHEET SIZE 8 1/2 x 6 +	CAP. 2	ORDER NO.
CUSTOMER		DUE DATE

QUANTITY	
DATE	

RADIUS	1/4
COMPLETED	

TEAR SEAL	
BAR SEAL	

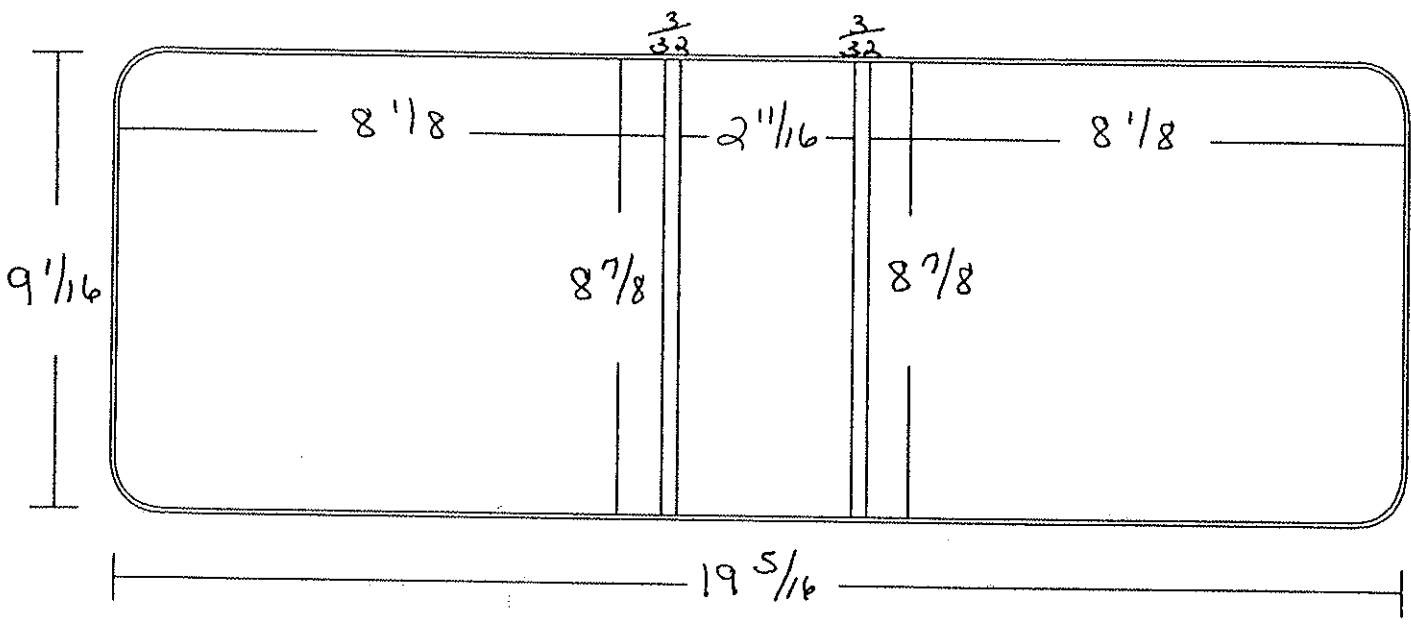

MATERIAL

	CODE	GA	PCS		CODE	GA	PCS
COVER MATL	9 3/4 X 20 1/16		1	LINING	9 3/4 X 20 1/16		1
COVER MATL	X			LINING	X		
VERT PKT	X			HORZ PKT	1-side 4 3/8 X 8 5/8		1
VERT PKT	X			HORZ PKT	Full 4 3/8 X 20 1/16		1
CARD HOLDER	X			DIAGONAL PKT	X		
COL	9 3/16 X 20 1/16			LABEL HOLDER	X		
EX. COL	9 3/16 X 12 1/16		1	GUSSETT	X		
Not in Ex. Col	9 3/16 X 11 5/8		1	REINF.	X		
	X				X		

PRINTS

FRONT COVER	X	BACK BONE	X	BACK COVER	X
-------------	---	-----------	---	------------	---

BOARDS

	CODE	PT	PCS		CODE	PT	PCS
F.C. BOARD	8 25/32 X 8 1/32	120	1	F.C. BOARD	X		
B.B. BOARD	8 25/32 X 2 19/32	120	1	B.B. BOARD	X		
B.C. BOARD	8 25/32 X 8 1/32	120	1	B.C. BOARD	X		
B. UP STRIP	X				X		
	X				X		

Product Code

Style Case V R B

Sheet Size 8 1/2 x 6 1/2 Cap. 1 1/2 Die No. 3968 Order No. 957959 Plate

Customer Shepard's Millbrae

Metal
Total Vinyl
Quantity
Date
Type Corners <u>RD</u>
Radius <u>1/8</u>
Completed

	Gauge	Thick
Tear Seal	<u>16</u>	<u>872</u>
Bar Seal	<u>16</u>	<u>872</u>
Bar Seal		

	No. of Feet
Tear Seal	
Bar Seal	
Bar Seal	

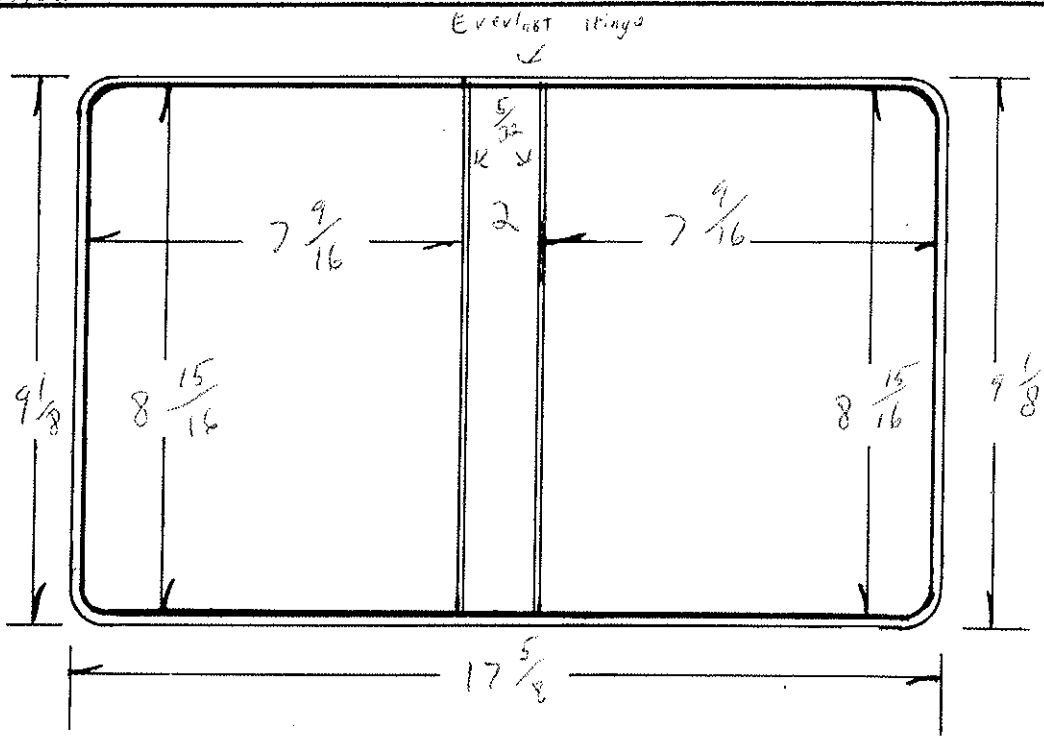

Code		Cutting Specs.		Code		Cutting Specs.			
		Ga.	# PCS	Size	Out	Ga.	# PCS	Size	Out
Cover Mat.	<u>9 3/4 X 18 3/8</u>		<u>1</u>			Lining Mat.	<u>9 3/4 X 18 3/8</u>		<u>1</u>
Cover Mat.	<u>X</u>					Lining Mat.	<u>X</u>		
Vert. Pckt.	<u>X</u>					Horz. Pckt.	<u>5 3/8 X 8 3/16</u>		
Vert. Rckt.	<u>X</u>					Horz. Pckt.	<u>X</u>		
Pocket	<u>X</u>					Pocket	<u>X</u>		
Label Holder	<u>X</u>					Card Holder	<u>X</u>		
Material	<u>X</u>					Material	<u>X</u>		
Material	<u>X</u>					Material	<u>X</u>		
Material	<u>X</u>					Material	<u>X</u>		
F.C. Board	<u>8 27/32 X 7 15/32</u>	<u>120</u>	<u>1</u>			B.C. Board	<u>8 27/32 X 7 15/32</u>	<u>120</u>	<u>1</u>
B.C. Board	<u>X</u>					B.B. Board	<u>8 27/32 X 1 29/32</u>	<u>120</u>	<u>1</u>
Center Board	<u>8 7/8 X 7 1/2</u>	<u>100</u>	<u>2</u>			Board	<u>X</u>		
Board	<u>8 7/8 X 1 29/32</u>	<u>100</u>	<u>1</u>			Strip	<u>X</u>		
Cover Pad	<u>X</u>					Strip	<u>X</u>		
						B.B. Pad	<u>X</u>		

OLD DIE # 3285

Style Case VRB

Product Code

Sheet Size $8\frac{1}{2} \times 6\frac{5}{8}$ Cap. 2" Die No. 4125 Order No. 961547.1 Plate

Customer SOFTWARE OF THE FUTURE

Metal
Total Vinyl
Quantity
Date
Type Corners
Radius
Completed

	Gauge	Thick
Tear Seal	016	3/32
Bar Seal	016	3/32
Bar Seal		

	No. of Feet
Tear Seal	
Bar Seal	
Bar Seal	

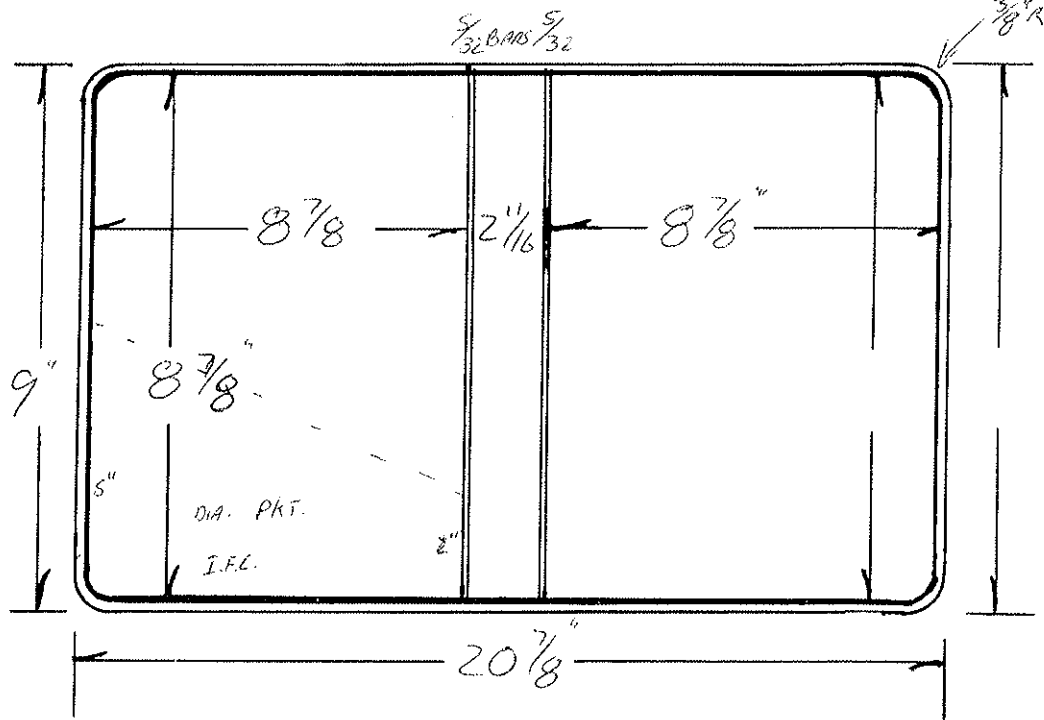

Code	Ga.	# PCS	Cutting Specs		Code	Ga.	# Pcs.	Cutting Specs	
			Size	Out				Size	Out
Cover Mat.		15	$9\frac{3}{4} \times 21\frac{5}{8}$	1	Lining Mat.		15	$9\frac{3}{4} \times 21\frac{5}{8}$	1
Cover Mat			X		Lining Mat.			X	
Vert. Pckt.			X		Horz. Pckt.			X	
Vert. Pckt.			X		Horz. Pckt.			X	
Pocket			X		Pocket		15	$7\frac{3}{4} \times 9\frac{3}{8}$	1
Label Holder			X		Card Holder			X	
Material			X		Material			X	
Material			X		Material			X	
Material			X		Material			X	
F.C. Board		85	$8\frac{25}{32} \times 8\frac{25}{32}$	1	B.C. Board			X	
B.C. Board		85	$8\frac{25}{32} \times 8\frac{25}{32}$	1	B.B. Board		85	$8\frac{25}{32} \times 21\frac{9}{32}$	1
Center Board			$8\frac{13}{16} \times 8\frac{13}{16}$	2	Board			X	
Board			$8\frac{13}{16} \times 2\frac{5}{8}$	1	Strip			X	
Cover Pad			X		Strip			X	
					B.B. Pad			X	

STOCK STR 0 metals will not work in this case. Use Die # 4100 for STR 0 metals

DIE # 4128	STYLE CASE VRB	Angle 2 LDC	LOCATION
SHEET SIZE 8'1/2 x 6	+ CAP. 1'1/2"	ORDER NO.	
CUSTOMER			DUE DATE

QUANTITY	
DATE	

RADIUS	3/8"
COMPLETED	

TEAR SEAL	
BAR SEAL	

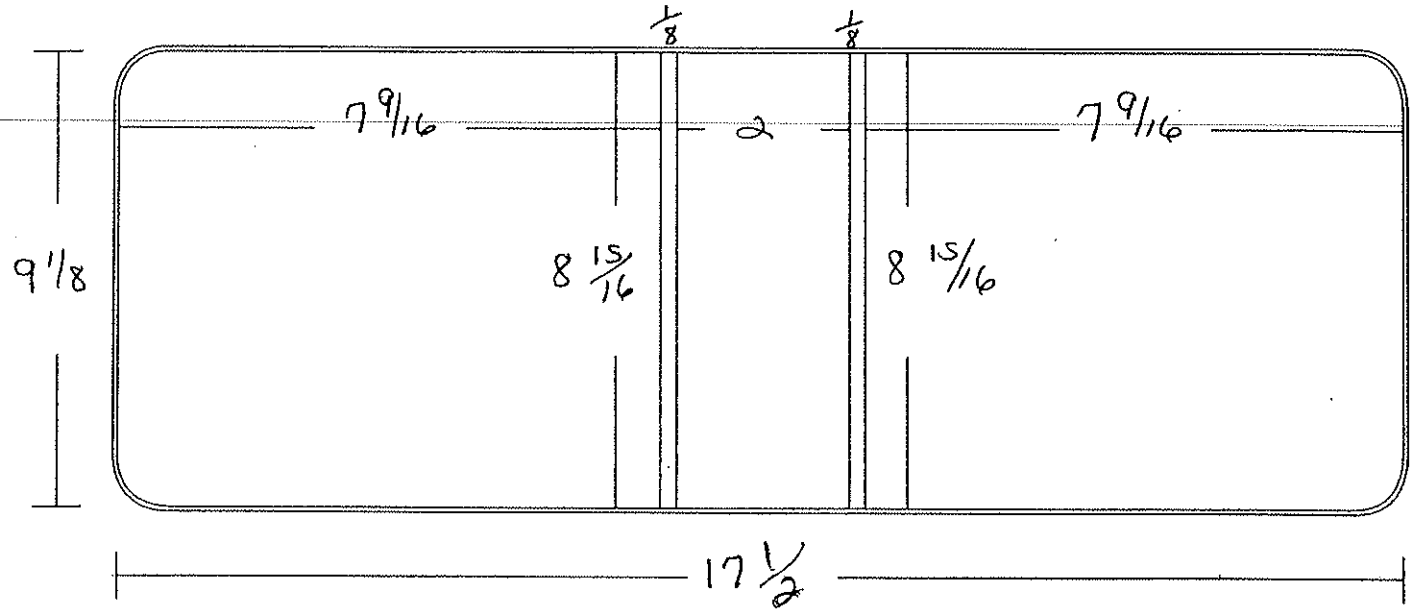

MATERIAL

	CODE	GA	PCS		CODE	GA	PCS
COVER MATL	9 3/4 X 18 3/8		1	LINING	9 3/4 X 18 3/8		1
COVER MATL	X			LINING	X		
VERT PKT	X			HORZ PKT	1-sided 4 3/8 X 8 1/16		1
VERT PKT	X			HORZ PKT	Full 4 3/8 X 18 3/8		
CARD HOLDER	X			DIAGONAL PKT	X		
COL	9 1/4 X 18 3/8		1	LABEL HOLDER	X		
EX. COL	9 1/4 X 10 7/8		1	GUSSETT	X		
No Trim For Col	9 1/4 X 10 7/16		1	REINF.	X		
	X				X		

PRINTS

FRONT COVER	X	BACK BONE	X	BACK COVER	X
-------------	---	-----------	---	------------	---

BOARDS

	CODE	PT	PCS		CODE	PT	PCS
F.C. BOARD	8 7/8 X 7 1/2	100	1	F.C. BOARD	8 27/32 X 7 15/32	120	1
B.B. BOARD	8 7/8 X 1 29/32	100	1	B.B. BOARD	8 27/32 X 1 29/32	120	1
B.C. BOARD	8 7/8 X 7 1/2	100	1	B.C. BOARD	8 27/32 X 7 15/32	120	1
B. UP STRIP	FC-BA BC X				X		
PODDED BD. DIE CUT	4128-B 12 1/4 X 16 1/2	100	1	PODDED AT FC-BB	12 1/4 X 19 3/16	2-40	

Product Code

Style Case **VRB**

Sheet Size **8 1/2 x 6** Cap. **1** Die No. **4201** Order No. **59025** Plate

Customer **EBSCO MEDIA ADV.**

Metal
Total Vinyl
Quantity 3,000
Date 4-28-89
Type Corners RND
Radius 3/8"
Completed

	Gauge	Thick
Tear Seal	016	3/32
Bar Seal		5/62
Bar Seal		

	No. of Feet
Tear Seal	
Bar Seal	
Bar Seal	

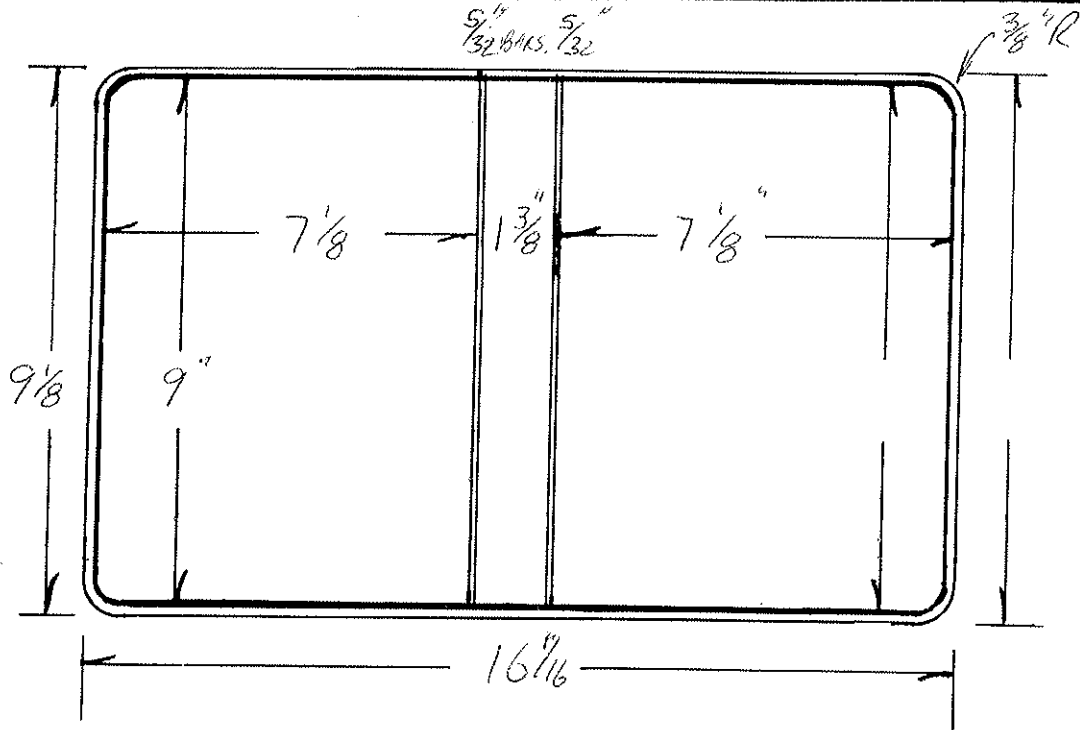

Code		Cutting Specs		Code		Cutting Specs			
		Ga.	# PCS	Size	Out	Ga.	# PCS	Size	Out
Cover Mat.	9 7/8 x 16 7/8"	15	1			Lining Mat.	9 7/8 x 16 7/8"	15	1
Cover Mat	X					Lining Mat.	X		
Vert. Pckt.	X					Horz. Pckt.	FLAT X CUT		
Vert. Pckt.	X					Horz. Pckt.	4 7/8 x 7 5/8	8	1
Pocket	X					Pocket	X		
Label Holder	X					Card Holder	X		
Material	X					Material	X		
Material	X					Material	X		
Material	X					Material	X		
F.C. Board	8 29/32 x 7 1/32	120	1			B.C. Board	X		
B.C. Board	8 29/32 x 7 1/32	120	1			B.B. Board	8 29/32 x 1 9/32	120	1
Center Board	8 15/16 x 7 1/16	100	2			Board	X		
Board	8 15/16 x 1 9/32	100	1			Strip	X		
Cover Pad	X					Strip	X		
						B.B. Pad	X		

DIE # 4202		STYLE CASE VINYL RING BINDER		LOCATION	
SHEET SIZE 8 1/2 X 6		CAP. 1 1/2		ORDER #	
CUSTOMER				DUE DATE	
QUANTITY		RADIUS	3/8	TEAR SEAL	.016
DATE		COMPLETED		BAR SEAL	484

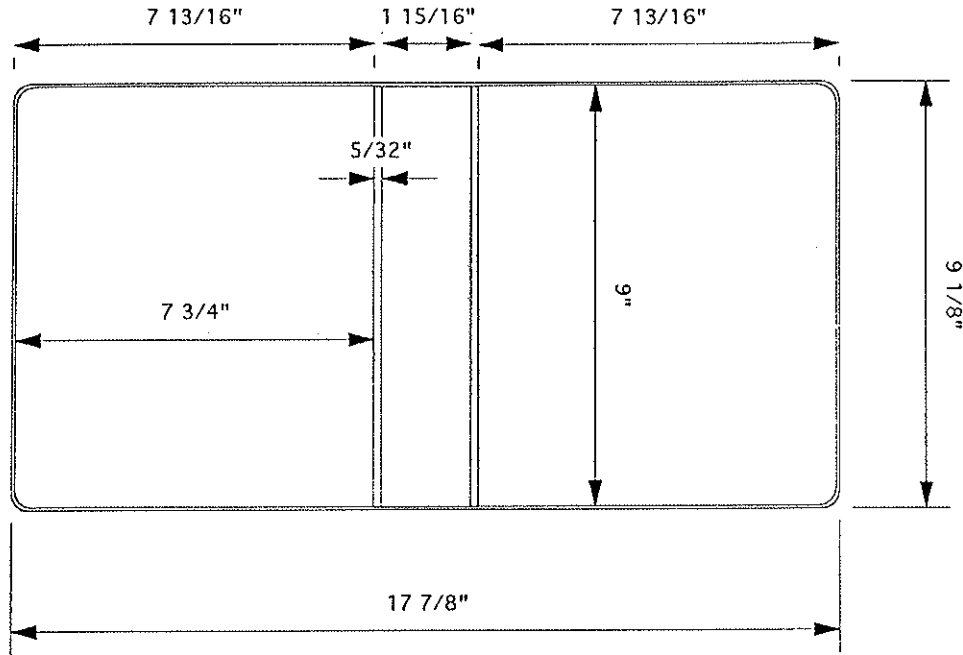

MATERIAL SPECS		GA	PCS			GA	PCS
COVER MATL	9 7/8 X 18 5/8		1	LINING	9 7/8 X 18 5/8		1
COVER MATL				LINING			
VERT PKT				HORZ PKT			
VERT PKT				HORZPKT	4 7/8 X 8 1/4		1
CARD HOLDER				DIAGONAL PKT			
COL				LABEL HOLDER			
EX COL				GUSSETT			
				REINF			

BOARD SPECS							
F.C. BOARD	8 15/16 X 7 11/16	100	1	F.C. BOARD	8 29/32 x 7 21/32	120	1
B.B. BOARD	8 15/16 X 1 27/32	100	1	B.B. BOARD	8 29/32 x 1 27/32	120	1
B.C. BOARD	8 15/16 X 7 11/16	100	1	B.C. BOARD	8 29/32 x 7 21/32		
BU STRIP							

Product Code

Style Case *VRB* *15RING GBC METAL*

Sheet Size *8 1/2* X *6*

Cap. *1/2*

Die No. *4705*

Order No. *968176*

Plate *C-13-*

Customer

COLAD GROUP INC.

Metal
Total Vinyl
Quantity <i>1,500</i>
Date <i>4-4-91</i>
Type Corners
Radius <i>3/8</i>
Completed

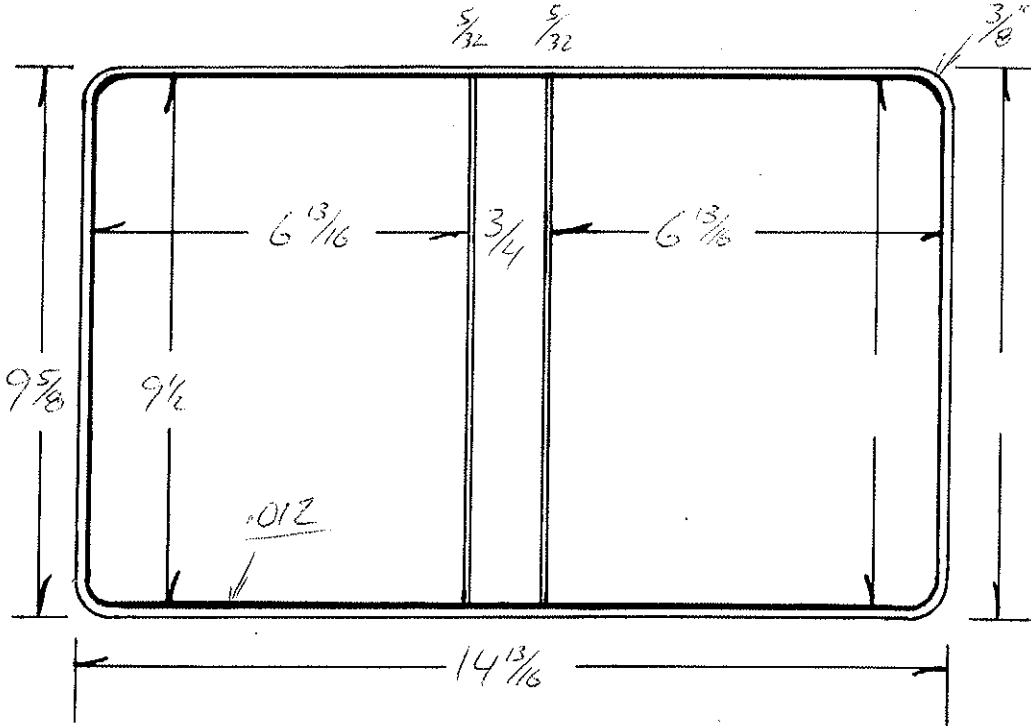

	Gauge	Thick
Tear Seal	<i>.012</i>	<i>1/16</i>
Bar Seal	<i>#254</i>	<i>5/32</i>
Bar Seal		

	No. of Feet
Tear Seal	
Bar Seal	
Bar Seal	

SIZE - B.PAC
CHECK *RPV*

Code		Cutting Specs				Code		Cutting Specs			
		Ga.	PCS	Size	Out			Ga.	PCS	Size	Out
Cover Mat.	<i>10 3/8 X 15 5/8</i>					Lining Mat.	<i>10 3/8 X 15 5/8</i>				
Cover Mat	X					Lining Mat.	X				
Vert. Pckt.	X					Horz. Pckt.	X				
Vert. Pckt.	X					Horz. Pckt.	X				
Pocket	X					Pocket	X				
Label Holder	X					Card Holder	X				
Material	X					Material	X				
Material	X					Material	X				
Material	X					Material	X				
F.C. Board	<i>9 13/32 X 6 23/32</i>	<i>100</i>	<i>1</i>			B.C. Board	X				
B.C. Board	<i>9 13/32 X 6 23/32</i>	<i>100</i>	<i>1</i>			B.B. Board	<i>9 13/32 X 2 1/32</i>	<i>100</i>	<i>1</i>		
Center Board	X					Board	X				
Board	X					Strip	X				
Cover Pad	X					Strip	X				
						B.B. Pad	X				

Product Code

OLD # 2661

Style Case **VRB**

Sheet Size **8 1/2 x 6 1/2**

Cap. **1 1/2**

Die No. **4753**

Order No. **968446**

Plate **C-14**

Customer

SIMPRO

Metal	
Total Vinyl	
Quantity	1000
Date	5-9-91
Type Corners	
Radius	3/4
Completed	

	Gauge	Thick
Tear Seal	.014	1/16
Bar Seal	253	1/8
Bar Seal		

	No. of Feet
Tear Seal	
Bar Seal	
Bar Seal	

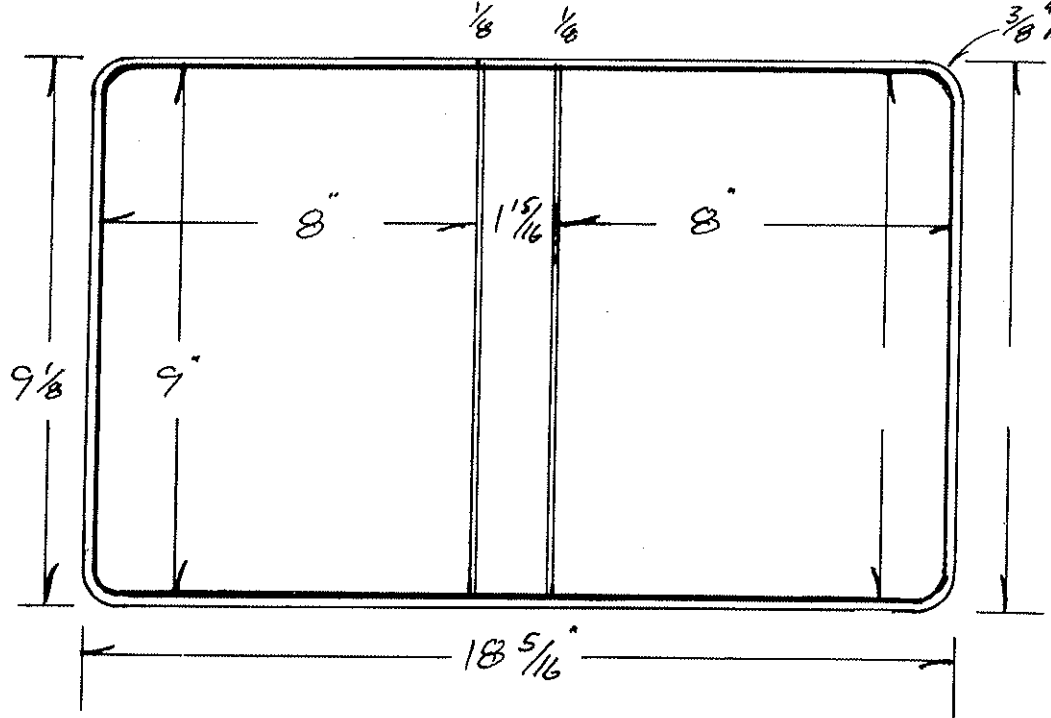

DWG. B. Pace
 Check- **PRV**

Code	Ga.	Pcs	Cutting Specs		Code	Ga.	Pcs	Cutting Specs	
			Size	Out				Size	Out
Cover Mat.			$9 \frac{3}{4}$	$19 \frac{1}{2}$	Lining Mat.			$9 \frac{3}{4}$	$19 \frac{1}{2}$
Cover Mat			X		Lining Mat.			X	
Vert. Pckt.			X		Horz. Pckt.			X	
Vert. Pckt.			X		Horz. Pckt.			X	
Pocket			X		Pocket			X	
Label Holder			X		Card Hlder			X	
Material			X		Material			X	
Material			X		Material			X	
Material			X		Material			X	
F.C. Board			$8 \frac{29}{32}$	$7 \frac{29}{32}$	B.C. Board			$8 \frac{29}{32}$	$7 \frac{29}{32}$
B.C. Board			$8 \frac{29}{32}$	$7 \frac{29}{32}$	B.B. Board			$8 \frac{29}{32}$	$1 \frac{27}{32}$
Center Board			$8 \frac{15}{16}$	$7 \frac{15}{16}$	Board			X	
Board B/B			$8 \frac{15}{16}$	$1 \frac{27}{32}$	Strip			X	
Cover Pad			X		Strip			X	
					B.B. Pad			X	

DIE #	4801	STYLE CASE	VRB	LOCATION	
SHEET SIZE	8 1/2 x 6 +	CAP.	2 1/2"	ORDER NO.	
CUSTOMER				DUE DATE	

QUANTITY	
DATE	

RADIUS	3/8
COMPLETED	

TEAR SEAL	
BAR SEAL	

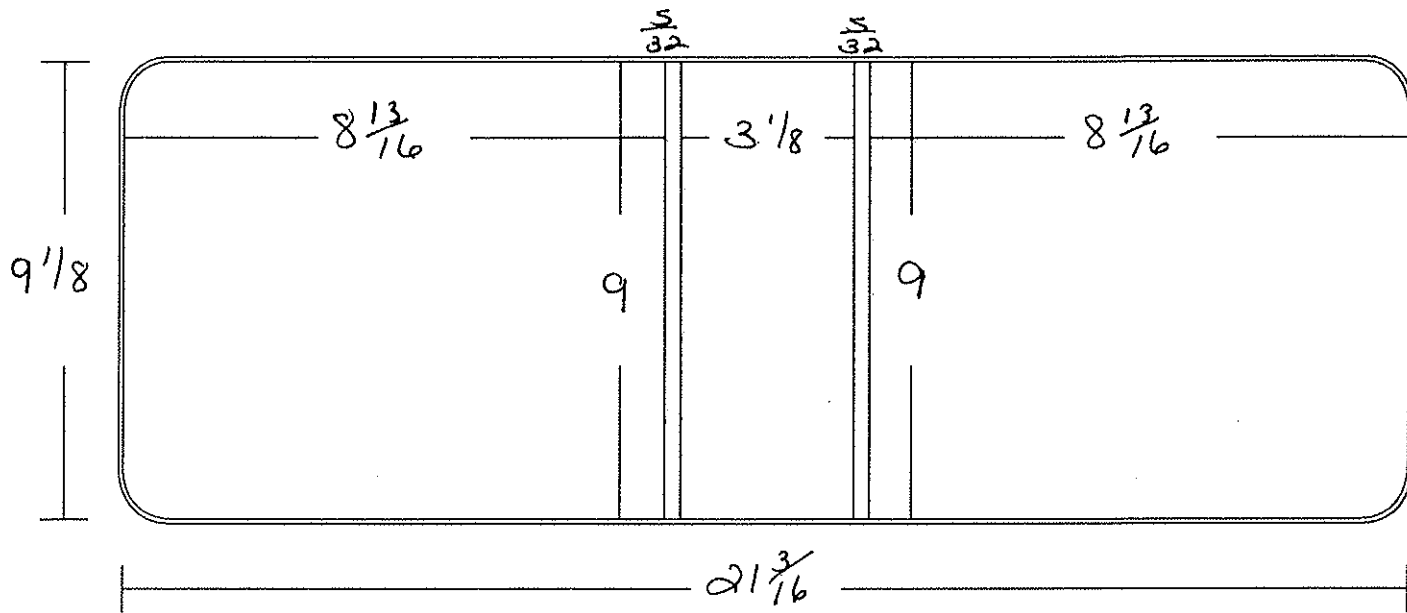

MATERIAL

	CODE	GA	PCS		CODE	GA	PCS
COVER MATL		9 3/4 X 22	1	LINING		9 3/4 X 22	1
COVER MATL		X		LINING		X	
VERT PKT		X		HORZ PKT	1-sided	4 3/8 X 9 3/8	1
VERT PKT		X		HORZ PKT	Full	4 3/8 X 22	1
CARD HOLDER		X		DIAGONAL PKT		X	
COL		9 1/4 X 22	1	LABEL HOLDER		X	
EX. COL		9 1/4 X 13 1/2	1	GUSSETT		X	
Do Trim EX. COL		9 1/4 X 12 7/8		REINF.		X	
		X				X	

PRINTS

FRONT COVER	X	BACK BONE	X	BACK COVER	X
-------------	---	-----------	---	------------	---

BOARDS

	CODE	PT	PCS		CODE	PT	PCS
F.C. BOARD		8 29/32 X 8 23/32	120	1	F.C. BOARD		X
B.B. BOARD		8 29/32 X 3 1/32	120	1	B.B. BOARD		X
B.C. BOARD		8 29/32 X 8 23/32	120	1	B.C. BOARD		X
B. UP STRIP		X					X
		X					X

Product Code

Style Case *URB* *8 1/2-17-1/2 MULTO*

Sheet Size *8 1/2 x 6*

Cap. *1/2 MULTO* Die No. *4844*

Order No. *969631*

Plate *C-17-8*

Customer

WILMONT PRINTING

8-26

Metal	
Total Vinyl	
Quantity	<i>500</i>
Date	<i>7-31-91</i>
Type Corners	
Radius	<i>3/8</i>
Completed	

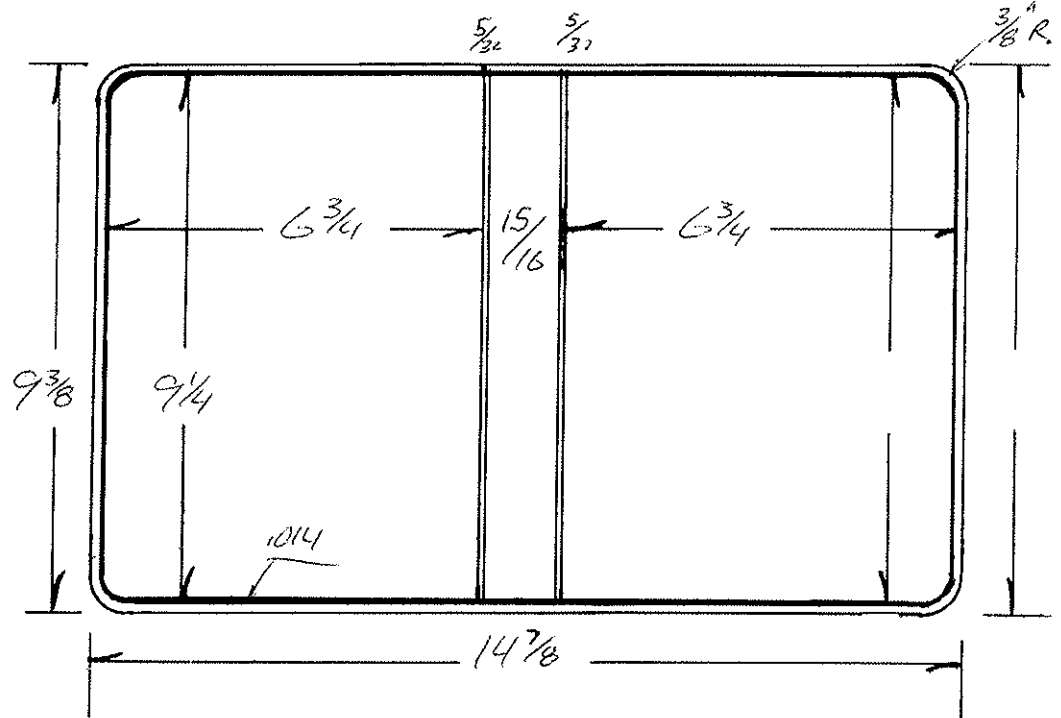

	Gauge	Thick
Tear Seal		
Bar Seal		
Bar Seal		

	No. of Feet
Tear Seal	
Bar Seal	
Bar Seal	

DWG. B. Pace
check RFD

Code	Ga.	#	PCS	Cutting Specs.		Code	Ga.	#	Pcs.	Cutting Specs.	
				Size	Out					Size	Out
Cover Mat.				<i>10 1/8</i>	<i>X 15 5/8</i>					<i>14</i>	<i>1</i>
Cover Mat					<i>X</i>	Lining Mat.				<i>10 1/8</i>	<i>X 15 5/8</i>
Vert. Pckt.					<i>X</i>	Lining Mat.				<i>X</i>	
Vert. Pckt.					<i>X</i>	Horz. Pckt.				<i>X</i>	
Pocket					<i>X</i>	Horz. Pckt.				<i>X</i>	
Label Holder					<i>X</i>	Pocket				<i>X</i>	
Material					<i>X</i>	Card Holder				<i>X</i>	
Material					<i>X</i>	Material				<i>X</i>	
Material					<i>X</i>	Material				<i>X</i>	
F.C. Board				<i>9 5/32</i>	<i>X 6 21/32</i>	Material				<i>X</i>	
B.C. Board				<i>9 5/32</i>	<i>X 6 21/32</i>	F.C. Board				<i>X</i>	
Center Board					<i>X</i>	B.C. Board				<i>9 5/32</i>	<i>X 27/32</i>
Board					<i>X</i>	B.B. Board				<i>100</i>	<i>1</i>
Cover Pad					<i>X</i>	Board				<i>X</i>	
						Strip				<i>X</i>	
						Strip				<i>X</i>	
						B.B. Pad				<i>X</i>	

Product Code

Style Case VRB

MULTO 8 1/2-17-1

Sheet Size 8 1/2 x 6

Cap. 1

Die No. 4866

Order No. 969900

Plate C-18-7

WILMOT PRINTING

9-13

Customer	
Metal	8 1/2-17-1 MULTO
Total Vinyl	
Quantity	
Date	500
Type Corners	8-27-91
Radius	
Completed	3/9

Tear Seal	Gauge	Thick
Bar Seal	.019	1/16
Bar Seal	.48-4	5/32

Tear Seal	No. of Feet
Bar Seal	
Bar Seal	

DWG-B.Pac
CHECK
KBR

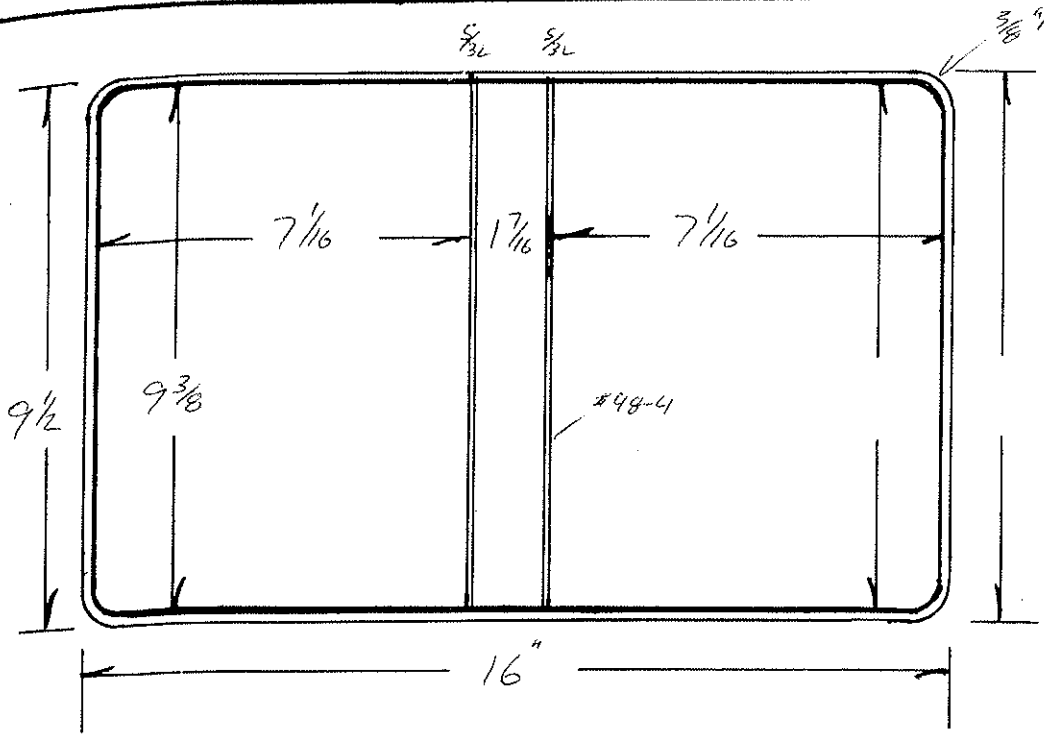

Code	Cutting Specs				Code	Cutting Specs															
	Ga.	#	PCS	Size		Out	Ga.	#	PCS	Size	Out										
Cover Mat.			10 1/4	X	16 3/4	14	1				Lining Mat.			10 1/4	X	16 3/4	14	1			
Cover Mat				X							Lining Mat.				X						
Vert. Pckt.				X							Horz. Pckt.				X						
Vert. Pckt.				X							Horz. Pckt.				X						
Pocket				X							Pocket				X						
Label Holder				X							Card Holder				X						
Material				X							Material				X						
Material				X							Material				X						
Material				X							Material				X						
F.C. Board			9 5/16	X	7"	100	1				B.C. Board				X						
B.C. Board			9 5/16	X	7"	100	1				B.B. Board			9 5/16	X	1 1/32	100	1			
Center Board				X							Board				X						
Board				X							Strip				X						
Cover Pad				X							Strip				X						
											B.B. Pad				X						

Product Code (8 1/2 x 7)

Style Case VRB

Sheet Size 8 1/2 x 6 1/2 + 1/2 Cap. 1

Die No. 4904

Order No. 970433

Plate D-1-4

Customer

BELL SOUTH COMM.

11-8

Metal
Total Vinyl
Quantity 100
Date 10-29-91
Type Corners
Radius 3/8
Completed

	Gauge	Thick
Tear Seal	.014	1/16
Bar Seal	.254	5/16
Bar Seal		

	No. of Feet
Tear Seal	
Bar Seal	
Bar Seal	

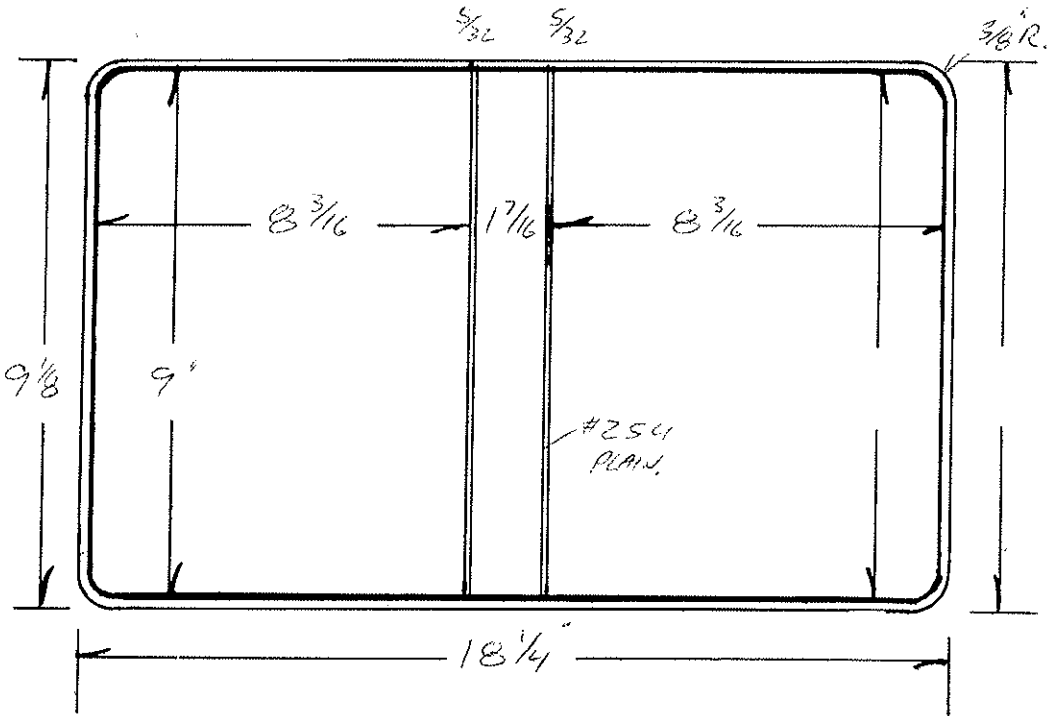

DWG. B. P. P.
CHECK *KRW*

PER SAMPLE

Code		Cutting Specs				Code		Cutting Specs			
		Ga.	# PCS	Size	Out			Ga.	# Pcs.	Size	Out
Cover Mat.	9 3/4 X 19		1			Lining Mat.	9 3/4 X 19		1		
Cover Mat	X					Lining Mat.	X				
Vert. Pckt.	X					Horz. Pckt.	X				
Vert. Rckt.	X					Horz. Pckt.	X				
Pocket	X					Pocket	X				
Label Holder	X					Card Holder	X				
Material	COL. 9 1/4 X 19	8	1			Material	X				
Material	X					Material	X				
Material	X					Material	X				
F.C. Board	8 5/16 X 8 1/8	C	1			B.C. Board	X				
B.C. Board	8 5/16 X 8 1/8	C	1			B.B. Board	8 5/16 X 1 1/32	C	1		
Center Board	X					Board	X				
Board	X					Strip	X				
Cover Pad	X					Strip	X				
						B.B. Pad	X				

Product Code

Style Case VRB

Sheet Size 8 1/2 x 5 1/2 Cap. 3"

Die No. 5164

Order No. 973360

Plate D11-5

Customer

Q911 Aircraft Modification

7-26

Metal	
Total Vinyl	
Quantity	<u>50</u>
Date	<u>9-9-92</u>
Type Corners	<u>RD</u>
Radius	<u>3/8</u>
Completed	

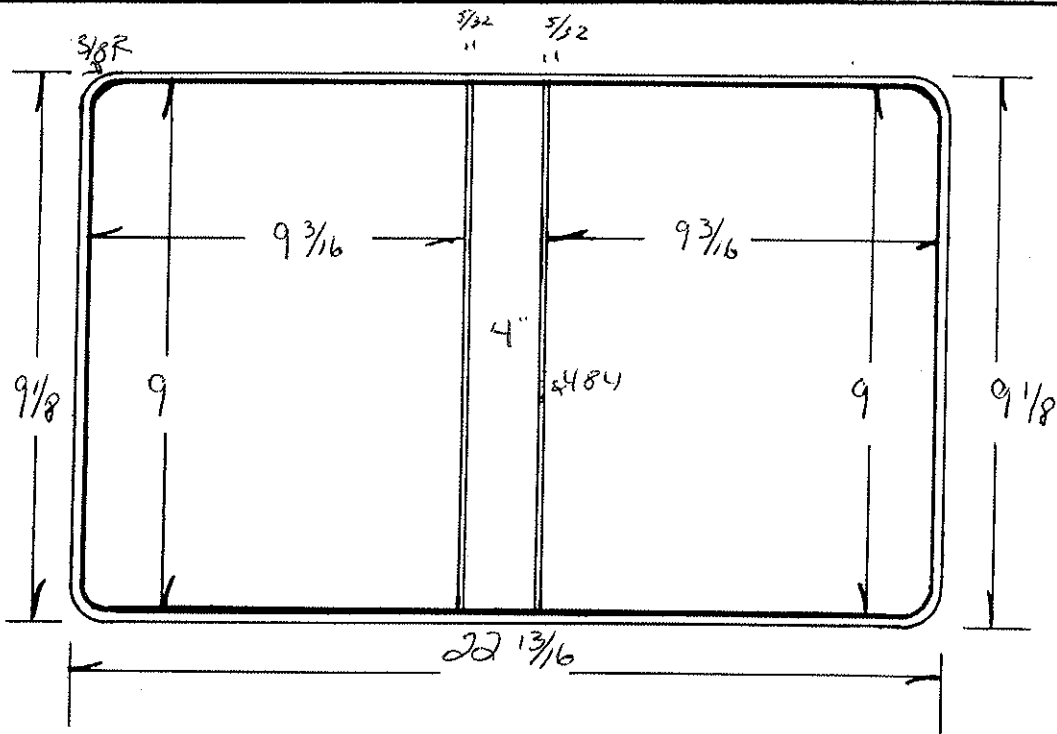

	Gauge	Thick
Tear Seal	<u>.014</u>	<u>1/16</u>
Bar Seal	<u>484</u>	<u>5/32</u>
Bar Seal		

	No. of Feet
Tear Seal	
Bar Seal	
Bar Seal	

Code	Ga.	#	Cutting Specs		Code	Ga.	#	Cutting Specs	
			Size	Out				Size	Out
Cover Mat.			<u>9 7/8 x 23 9/16</u>	<u>1</u>	Lining Mat.			<u>9 7/8 x 23 9/16</u>	<u>1</u>
Cover Mat.			X		Lining Mat.			X	
Vert. Pckt.			X		Horz. Pckt.			<u>4 3/8 x 23 9/16</u>	<u>1</u>
Vert. Pckt.			X		Horz. Pckt.			X	
Pocket			X		Pocket			X	
Label Holder			X		Card Holder			X	
Material			X		Material			X	
Material			X		Material			X	
Material			X		Material			X	
F.C. Board			<u>8 29/32 x 9 3/32</u>	<u>120</u>	B.C. Board			X	
B.C. Board			<u>8 29/32 x 9 3/32</u>	<u>120</u>	B.B. Board			X	
Center Board			<u>3 3/32 x 8 29/32</u>	<u>120</u>	Board			X	
Board size			<u>10' x 24</u>	<u>use die # 5164B</u>	Strip			X	
Cover Pad			X		Strip			X	
					B.B. Pad			X	

Product Code

Style Case

VRB

Sheet Size $8\frac{1}{2}$ x $11\frac{1}{2}$ Cap. 2

Die No. 5230

Order No. 973587

Plate D14-5

Customer

Lane Upholstery

12-23

Metal
Total Vinyl
Quantity 200
Date 12-3-92
Type Corners RND
Radius $\frac{3}{8}$
Completed

	Gauge	Thick
Tear Seal	.014	$\frac{1}{16}$
Bar Seal	48.4	$\frac{5}{32}$
Bar Seal		

	No. of Feet
Tear Seal	
Bar Seal	
Bar Seal	

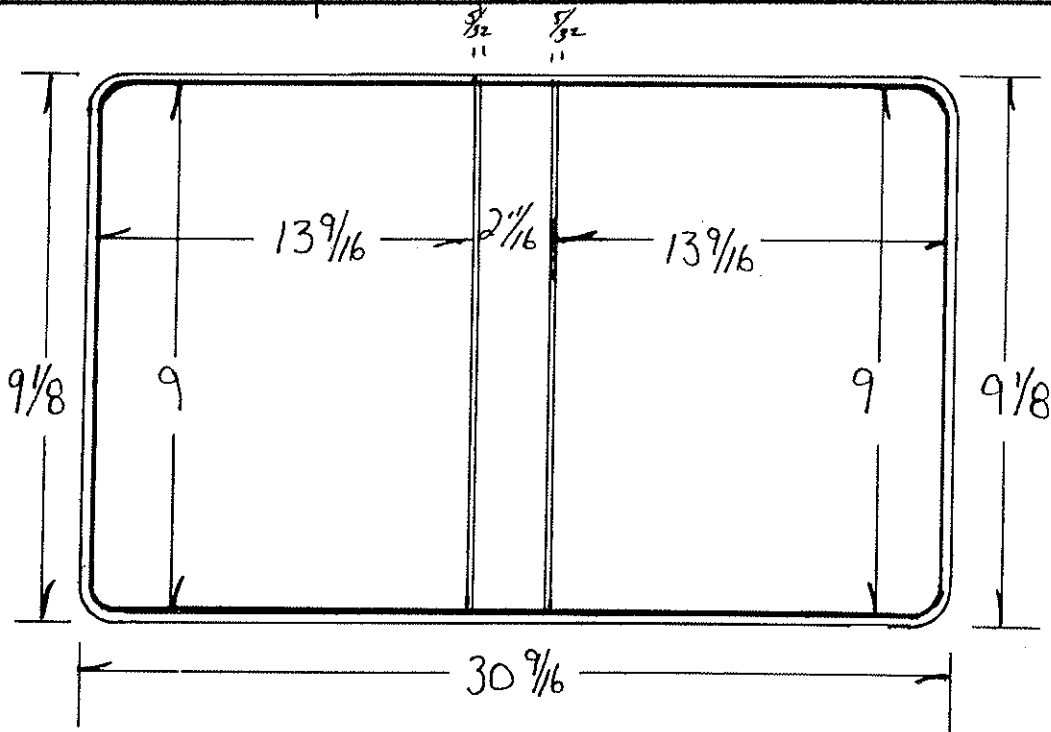

Tim

Code	Ga.	#	PCS	Cutting Specs		Code	Ga.	#	Pcs.	Cutting Specs	
				Size	Out					Size	Out
Cover Mat.						Lining Mat.					
	$9\frac{7}{8}$		1				$9\frac{7}{8}$		1		
Cover Mat.						Lining Mat.					
	X						X				
Vert. Pckt.						Horz. Pckt.					
	X						X				
Vert. Pckt.						Horz. Pckt.					
	X						X				
Pocket						Pocket					
	X						X				
Label Holder						Card Holder					
	X						X				
Material						Material					
	X						X				
Material						Material					
	X						X				
F.C. Board						B.C. Board					
	$8\frac{29}{32}$ X $13\frac{15}{32}$	120	1				$8\frac{17}{16}$ X $13\frac{1}{2}$	100	1		
B.C. Board						B.B. Board					
	$8\frac{29}{32}$ X $13\frac{15}{32}$	120	1				$8\frac{17}{16}$ X $2\frac{19}{32}$	100	1		
Center Board						Board					
	$8\frac{29}{32}$ X $2\frac{19}{32}$	120	1				$8\frac{17}{16}$ X $13\frac{1}{2}$	100	1		
Board						Strip					
	X						X				
Cover Pad						Strip					
	X						X				
						B.B. Pad					
							X				

" Same as Sample "

DIE #	5302	STYLE CASE	VRB	LOCATION	D17-8
SHEET SIZE	8 1/2 x 5 1/2 + 1/2	CAP.	1/2	ORDER NO.	974686.2
CUSTOMER	Concord Community Schools			DUE DATE	

QUANTITY	400
DATE	3-17-93

RADIUS	3/8
COMPLETED	

TEAR SEAL	.014
BAR SEAL	483

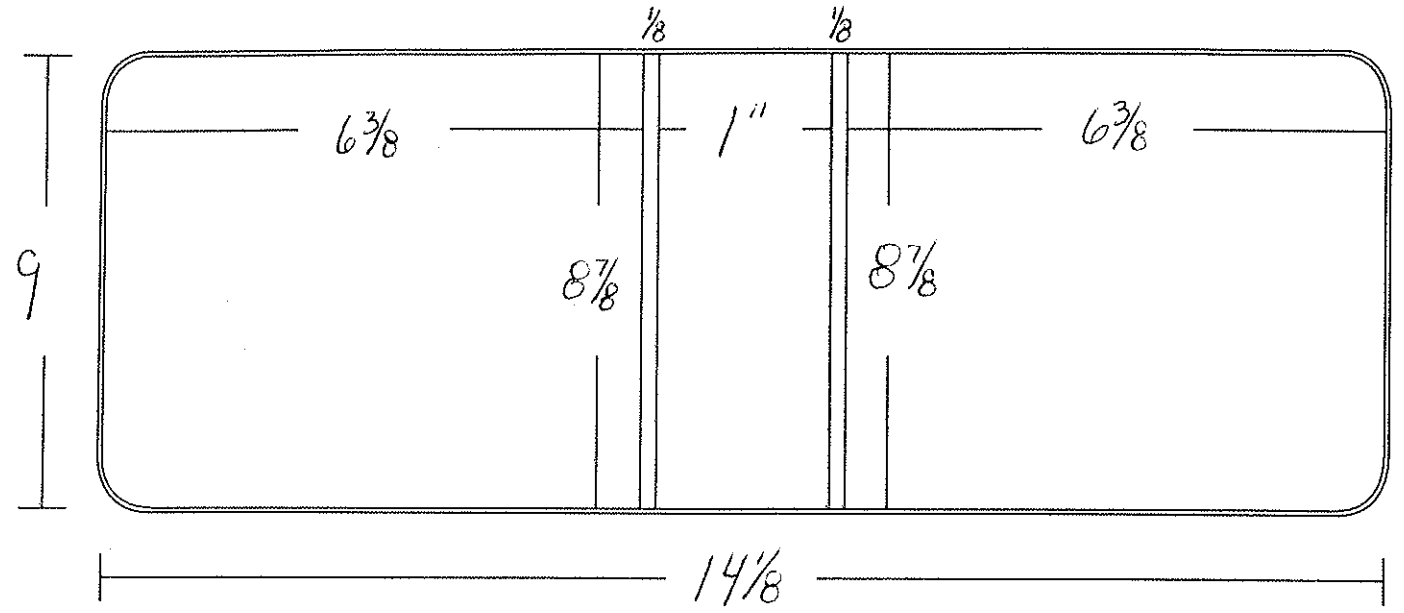

t.m

MATERIAL

	CODE		GA	PCS		CODE		GA	PCS
COVER MATL		9 3/4 X 14 7/8		1	LINING		9 3/4 X 14 7/8		1
COVER MATL		X			LINING		X		
VERT PKT		X			HORZ PKT		4 3/8 X 14 7/8		
VERT PKT		X			HORZ PKT		X		
CARD HOLDER		X			DIAGONAL PKT		X		
COL		X			LABEL HOLDER		X		
EX. COL		9 7/8 X 8 1/16		1	GUSSETT		X		
		X			REINF.		X		
		X					X		

PRINTS

FRONT COVER	X	BACK BONE	X	BACK COVER	X
-------------	---	-----------	---	------------	---

BOARDS

	CODE		PT	PCS		CODE		PT	PCS
F.C. BOARD		8 13/16 X 6 5/16	100	1	F.C. BOARD		8 27/32 X 6 9/32	120	1
B.B. BOARD		8 13/16 X 2 9/32	100	1	B.B. BOARD		8 27/32 X 2 9/32	120	1
B.C. BOARD		8 13/16 X 6 5/16	100	1	B.C. BOARD		8 27/32 X 6 9/32	120	1
B. UP STRIP		X					X		
		X					X		

DIE #	5686	CAP.	1 1/2	METAL	LOC ROUND RING
STYLE CASE	VINYL RING BINDER			LOCATION	E-16-1
SHEET SIZE	8 1/2 X 6	<i>(Matched Sample)</i>		ORDER #	979616
CUSTOMER	COLAD			DUE DATE	10-17-94
QUANTITY	1	RADIUS	3/8	TEAR SEAL	.012
DATE	10-12-94	COMPLETED		BAR SEAL	48-4

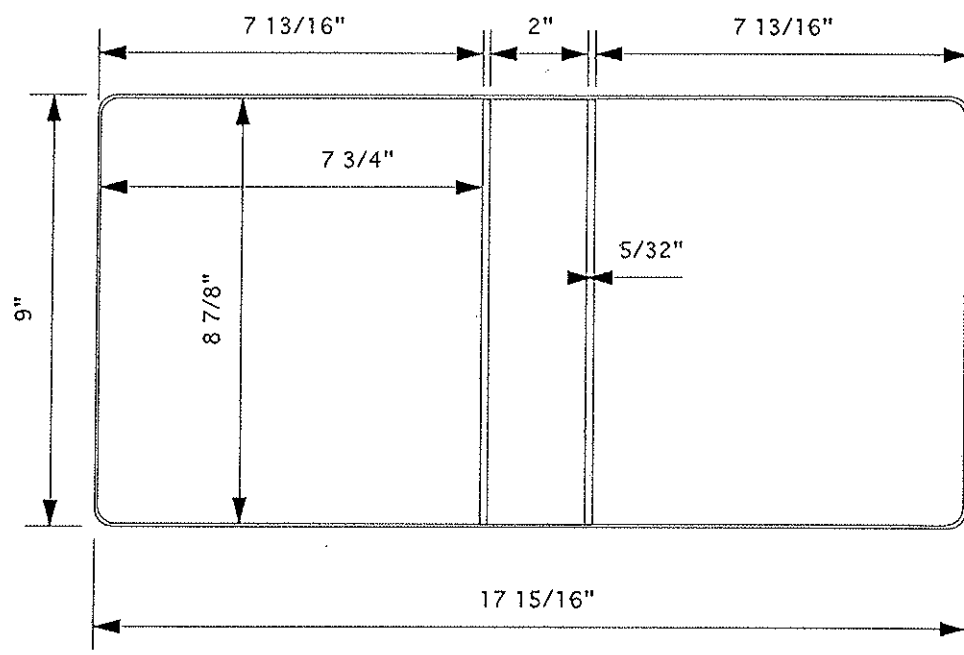

MATERIAL SPECS		GA	PCS	MATERIAL SPECS		GA	PCS
COVER MAT.	9 3/4 X 18 11/16	1		LINING MAT	9 3/4 X 18 11/16	1	
COVER MAT.				LINING MAT			
VERT PKT				HORZ PKT			
CARD HOLDER				GUSSET			
COL				DIAGONAL PKT			
LABEL HOLDER				REINF			
BOARD SPECS		GA	PCS	BOARD SPECS		GA	PCS
F.C. BOARD	8 13/16 X 7 11/16	100	1	F.C. BOARD			
B.B. BOARD	8 13/16 X 1 29/32	100	1	B.B. BOARD			
B.C. BOARD	8 13/16 X 7 11/16	100	1	B.C. BOARD			
B.U. STRIP							

DIE #	5720	CAP.	1"	METAL	7 RING 1"
STYLE CASE	1" VRB PADDED			LOCATION	E-17-5
SHEET SIZE	8 1/2 X 6		ORDER #	979993	
CUSTOMER	CONTINENTAL AIRLINES			DUE DATE	12-15-94
QUANTITY	750	RADIUS	3/8	TEAR SEAL	.014
DATE	11-30-94	COMPLETED		BAR SEAL	48-4

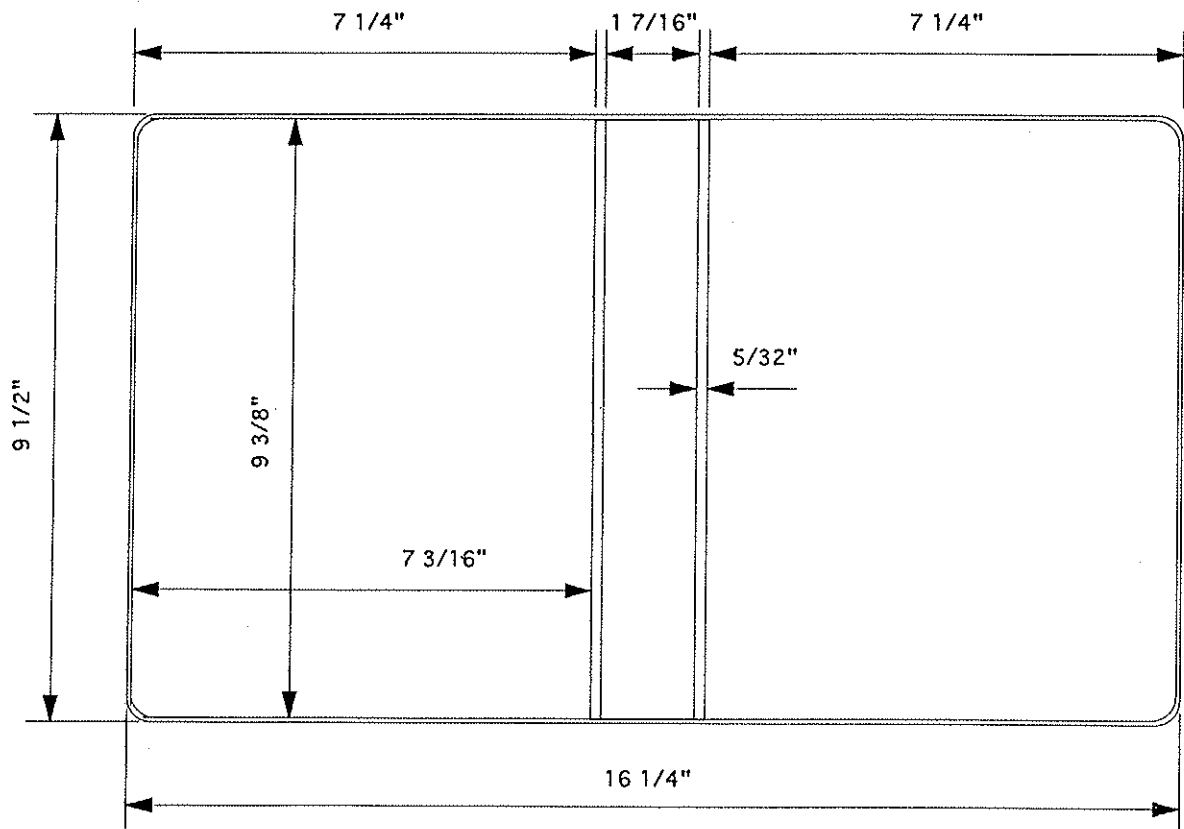

MATERIAL SPECS		GA	PCS			GA	PCS
COVER MAT.	10 1/2 X 17 1/4		1	LINING MAT	11 1/4 X 18	V223	1
COVER MAT.	(CASTILLIAN)			LINING MAT	(TO BE DIE CUT 5720-B)		
VERT PKT				HORZ PKT			
PEN LOOP	1 X 2 1/2	V223	1	GUSSET			
COL				R STYLE PKT	8 3/4 X 7 1/4	V223	1
LABEL HOLDER				REINF	(DIE 5720-C)		

BOARD SPECS		GA	PCS			GA	PCS
DIE CUT BD.	12 1/8 X 15 11/16	100	1	F.C. BOARD			
B.B. BOARD	(TO BE DIE CUT 5720-D)	PADDED		B.B. BOARD			
B.C. BOARD				B.C. BOARD			
B.U. STRIP							

DIE #	5754	CAP.	3"	METAL	3" SLANT D W/BOOSTERS	
STYLE CASE	VINYL RING BINDER			LOCATION	E-18-9	
SHEET SIZE	8 1/2 X 15 3/8		ORDER #	980305		
CUSTOMER	MISTER NEAT'S FORMAL WEAR			DUE DATE	1-27-95	
QUANTITY	100	RADIUS	3/8	TEAR SEAL	.014	
DATE	1-17-95	COMPLETED		BAR SEAL	48-4	

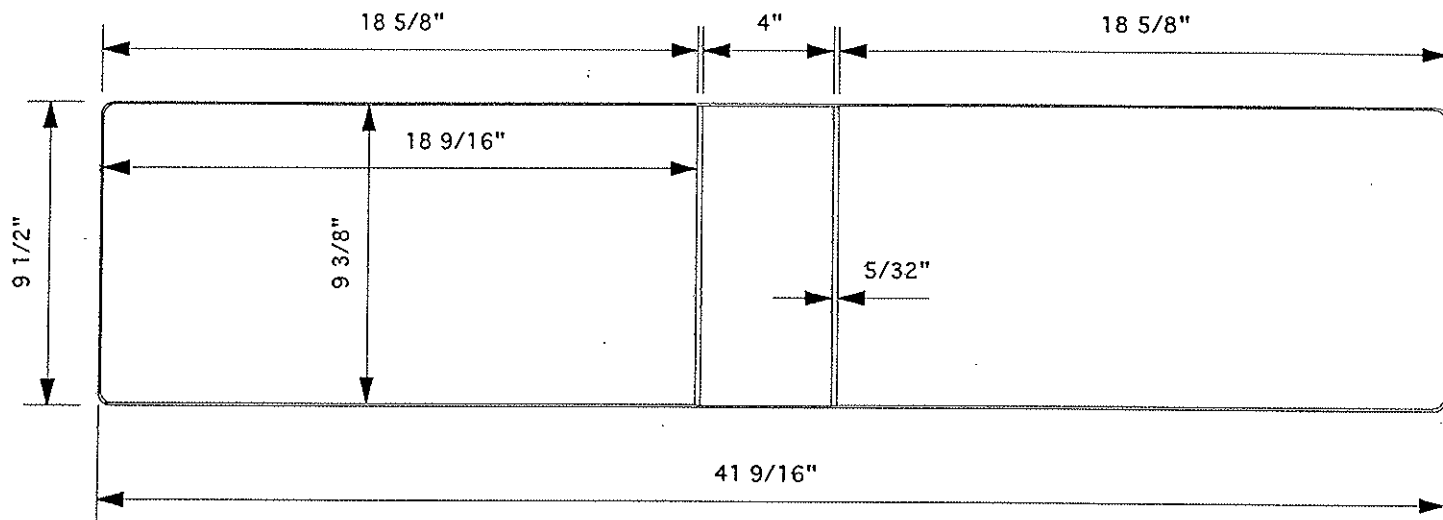

MATERIAL SPECS		GA	PCS	MATERIAL SPECS		GA	PCS
COVER MAT.	10 1/4 X 42 3/8	1		LINING MAT	10 1/4 X 42 3/8	1	
COVER MAT.				LINING MAT			
VERT PKT				HORZ PKT			
CARD HOLDER				GUSSET			
COL				DIAGONAL PKT			
LABEL HOLDER				REINF			
BOARD SPECS		GA	PCS	BOARD SPECS		GA	PCS
F.C. BOARD	9 9/32 X 18 15/32	120	1	F.C. BOARD			
B.B. BOARD	9 9/32 X 3 29/32	120	1	B.B. BOARD			
B.C. BOARD	9 9/32 X 18 15/32	120	1	B.C. BOARD			
B.U. STRIP							

DIE #	5859	METAL	NB ANGLE D	RADIUS	1/4
ORDER #	71062	CUSTOMER	CLAYTON QUORUM INC.	TEAR SEAL	.014
SHEET SIZE	8 1/2 X 5 3/4	STYLE CASE	VINYL RING BINDER	BAR SEAL	48-4
CAP.	1"	DUE DATE	6-29-95	COMPLETED	
LOCATION	F-8-2	QUANTITY	5000	DATE	6-21-95

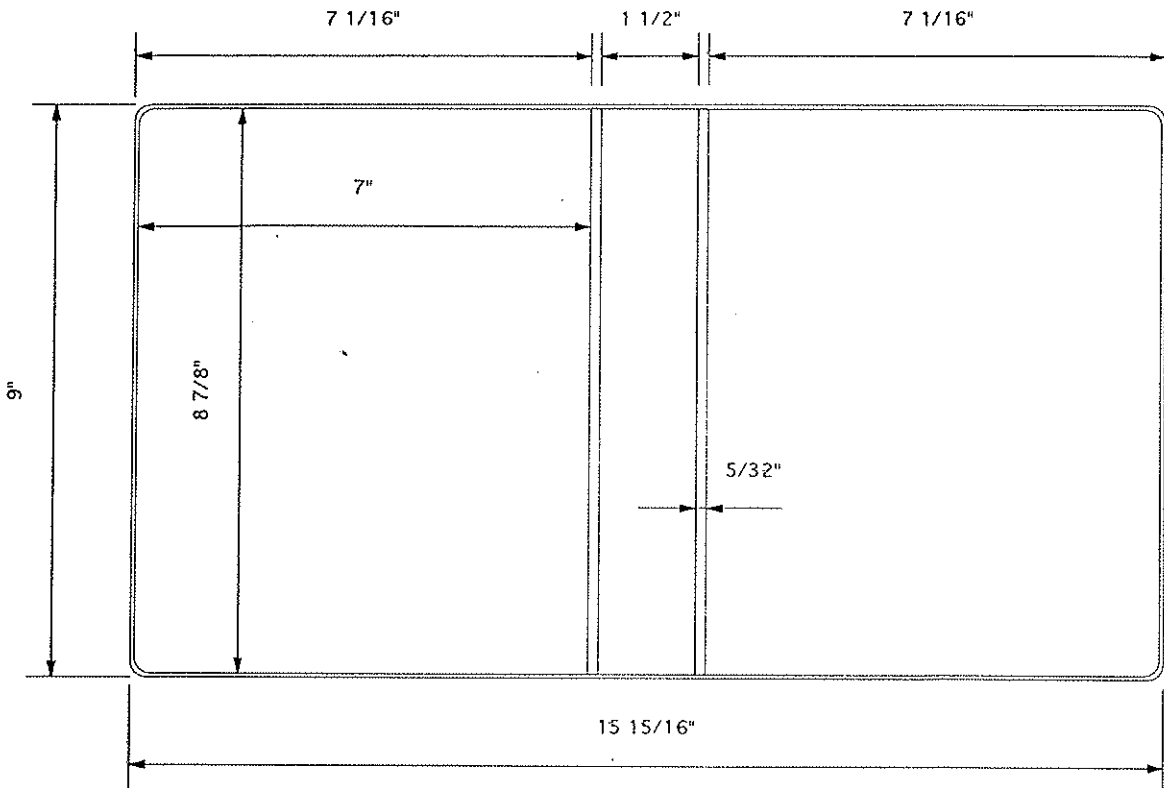

MATERIAL SPECS		GAUGE PCS.		MATERIAL SPECS		GAUGE P	
COVER MAT.	9 3/4 X 16 3/4		1	LINING MAT.	9 3/4 X 16 3/4		
COVER MAT.				LINING MAT.			
DIE CUT				HORZ. PKT.			
COL	9 3/16 X 9 1/4		1	VERT. PKT.			
LABEL HOLDER				DIE CUT			
GUSSET				REINF.			

BOARD SPECS		GAUGE PCS.		BOARD SPECS		GAUGE P	
F.C. BOARD	8 13/16 X 6 15/16	100	1	F.C. BOARD			
B.B. BOARD	8 13/16 X 1 13/32	100	1	B.B. BOARD			
B.C. BOARD	8 13/16 X 6 15/16	100	1	B.C. BOARD			
B.U. STRIP				DIE CUT			
DIE CUT				DIE CUT			

1' latched sample

DIE #	5872	METAL	LOC	RADIUS	
ORDER #	71240	CUSTOMER	LABOR RELATIONS INSTITUTE	TEAR SEAL	.012
SHEET SIZE	8 1/2 X 5 1/2	STYLE CASE	VINYL RING BINDER	BAR SEAL	102
CAP.	1/2"	DUE DATE	7-25-95	COMPLETED	
LOCATION	F-8-9	QUANTITY	1	DATE	7-20-95

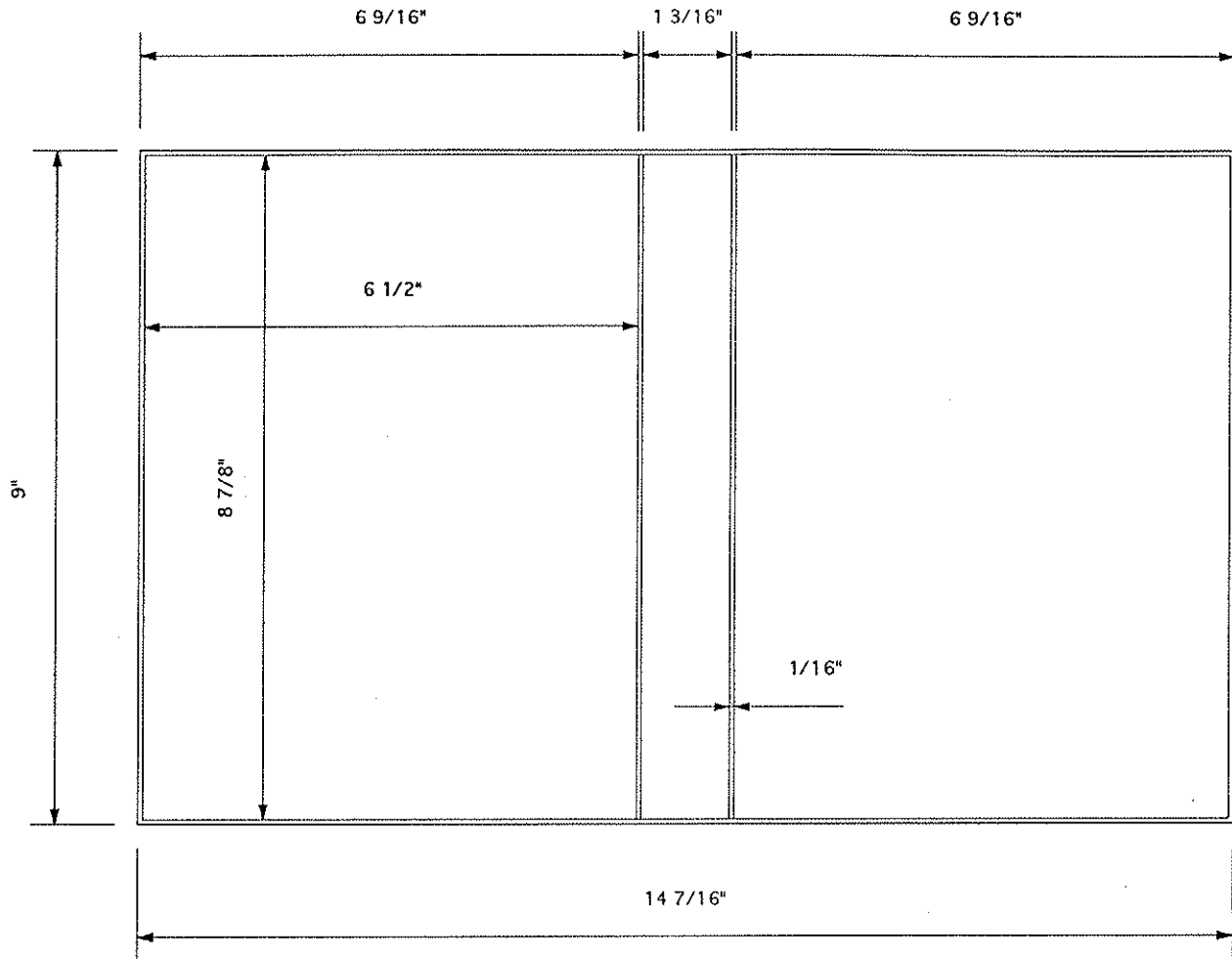

MATERIAL SPECS		GAUGE		PCS.		MATERIAL SPECS		GAUGE		PCS.	
COVER MAT.	9 3/4 X 15 1/4			1		LINING MAT.	9 3/4 X 15 1/4			1	
COVER MAT.						LINING MAT.					
DIE CUT	6 3/4 X 9 3/4 5872-B	2 OUT		1		HORZ. PKT.					
COL						VERT. PKT.					
LABEL HOLDER						DIE CUT					
GUSSET						REINF.					

BOARD SPECS		GAUGE		PCS.		BOARD SPECS		GAUGE		PCS.	
F.C. BOARD	8 13/16 X 6 7/16	100		1		F.C. BOARD					
B.B. BOARD	8 13/16 X 1 3/32	100		1		B.B. BOARD					
B.C. BOARD	8 13/16 X 6 7/16	100		1		B.C. BOARD					
B.U. STRIP						DIE CUT					
DIE CUT						DIE CUT					

Matched Sample

DIE #	5864	METAL	LOC	RADIUS	3/8
ORDER #	981880	CUSTOMER	L I D GROUP	TEAR SEAL	.014
SHEET SIZE	8 1/2 X 6	STYLE CASE	VINYL RING BINDER	BAR SEAL	253
CAP.	1/2"	DUE DATE	7-14-95	COMPLETED	
LOCATION	F-8-5	QUANTITY	200	DATE	7-5-95

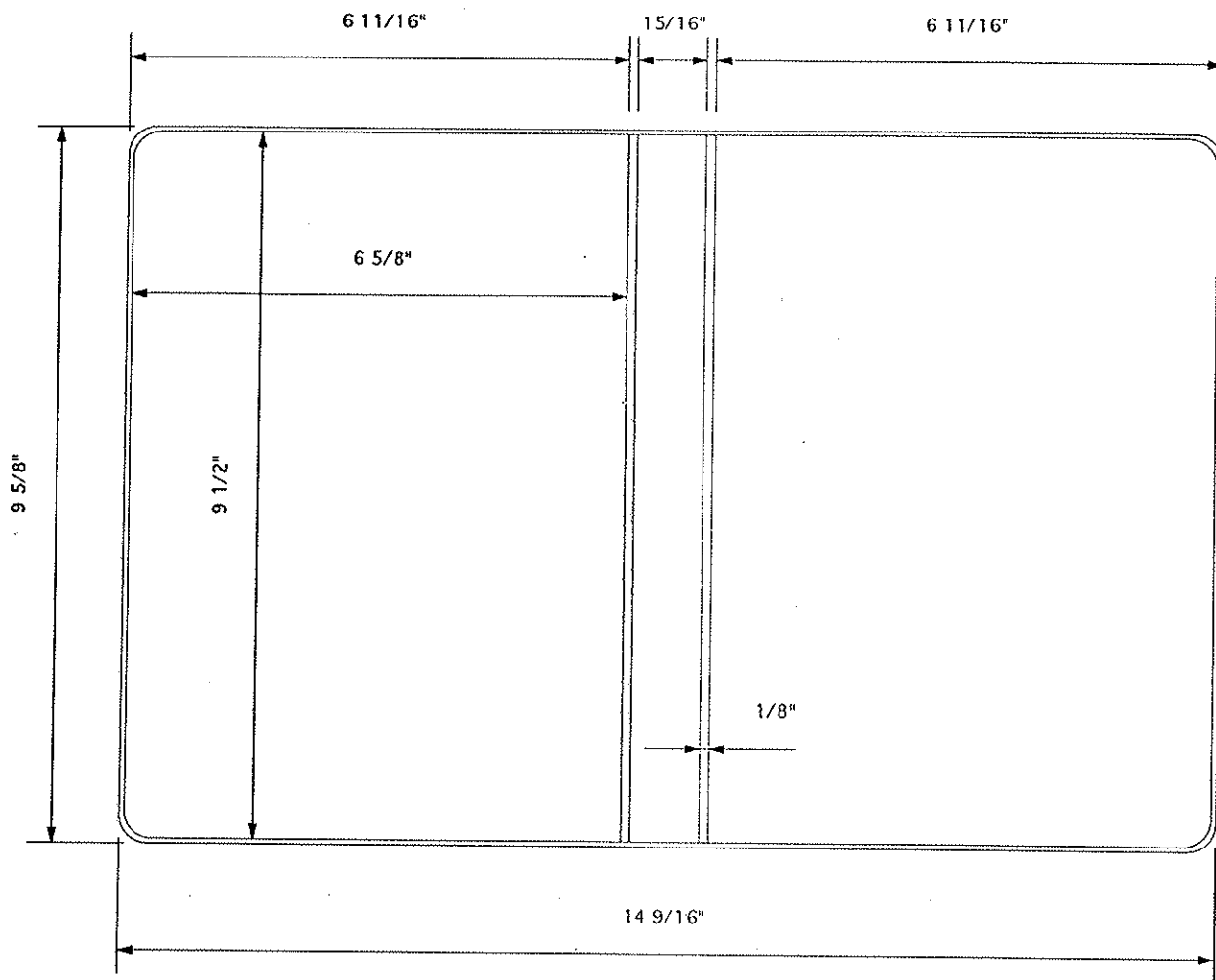

MATERIAL SPECS		GAUGE PCS.		MATERIAL SPECS		GAUGE PCS.	
COVER MAT.	10 3/8 X 15 1/4		1	LINING MAT.	10 3/8 X 15 1/4		1
COVER MAT.				LINING MAT.			
DIE CUT				HORZ. PKT.			
COL	9 3/4 X 8 1/2		1	VERT. PKT.			
LABEL HOLDER				DIE CUT			
GUSSET				REINF.			

BOARD SPECS		GAUGE PCS.		BOARD SPECS		GAUGE PCS.	
F.C. BOARD	9 7/16 X 6 9/16	100	1	F.C. BOARD			
B.B. BOARD	9 7/16 X 7/8	100	1	B.B. BOARD			
B.C. BOARD	9 7/16 X 6 9/16	100	1	B.C. BOARD			
B.U. STRIP				DIE CUT			
DIE CUT				DIE CUT			

DIE #	5958	METAL	1" LOC	RADIUS	12"
ORDER #	983130	CUSTOMER	PHILIP CRANE	TEAR SEAL	.014
SHEET SIZE	8 1/2 X 6	STYLE CASE	VINYL BASEBALL BINDER	BAR SEAL	253
CAP.	1"	DUE DATE	11-27-95	COMPLETED	
LOCATION	L-7-6	QUANTITY	20	DATE	11-16-9

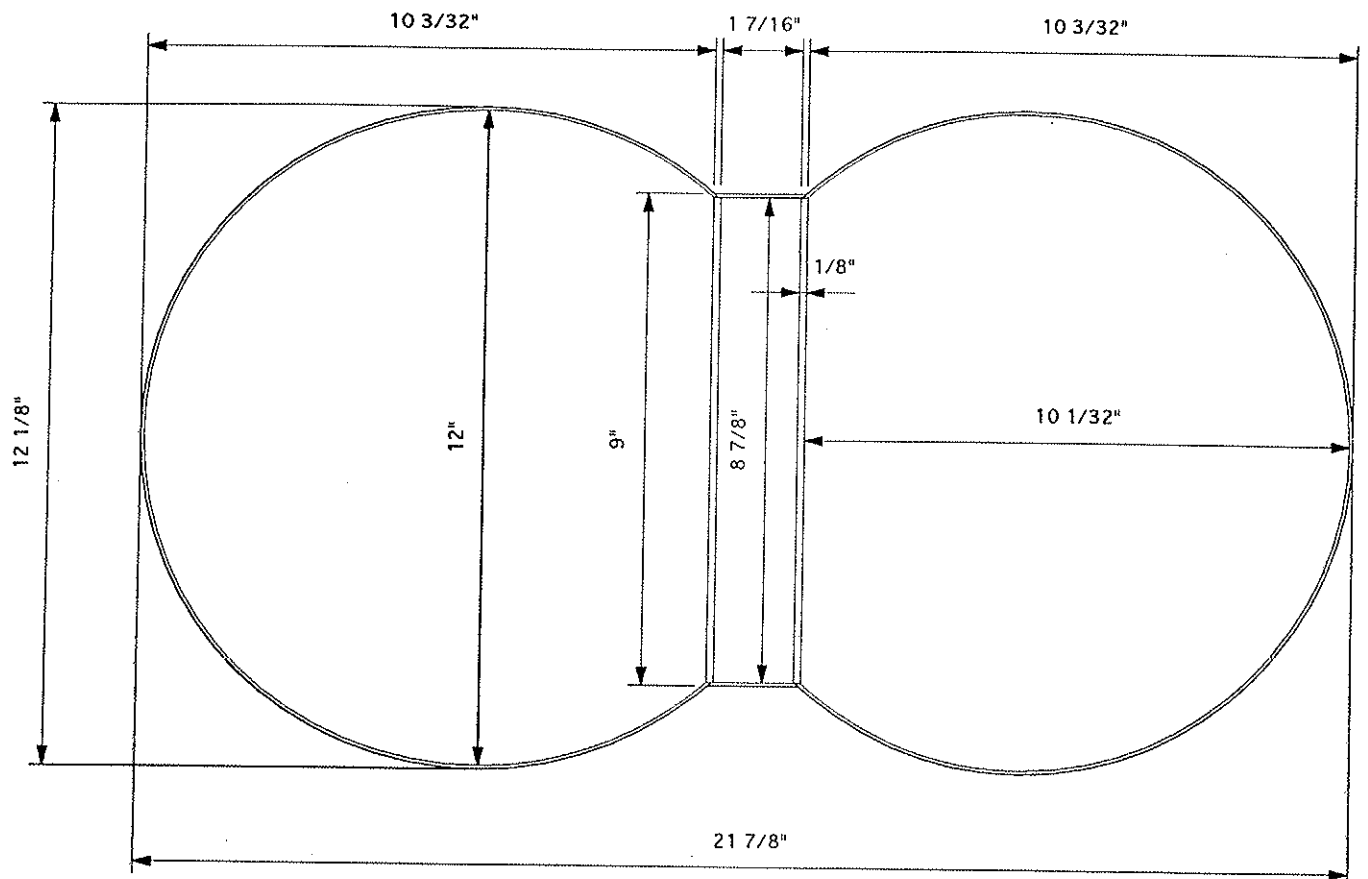

MATERIAL SPECS		GAUGE		MATERIAL SPECS		GAUGE	
COVER MAT.	12 7/8 X 22 5/8		1	LINING MAT.	12 7/8 X 22 5/8		
COVER MAT.				LINING MAT.			
DIE CUT				HORZ. PKT.			
COL				VERT. PKT.			
LABEL HOLDER				DIE CUT			
GUSSET				REINF.			
BOARD SPECS		GAUGE		BOARD SPECS		GAUGE	
F.C. BOARD				F.C. BOARD			
B.B. BOARD	8 25/32 X 1 11/32	100	1	B.B. BOARD			
B.C. BOARD				B.C. BOARD			
B.U. STRIP				DIE CUT			
DIE CUT	13 X 11	DIE 5958-A (1 OUT)	100	2	DIE CUT		

DIE #	6018	METAL	7 RING W/ BOOSTER	RADIUS	3/8
ORDER #	984071	CUSTOMER	CONTINENTAL AIRLINES	TEAR SEAL	.014
SHEET SIZE	8 1/2 X 6	STYLE CASE	VINYL RING BINDER	BAR SEAL	48-4
CAP.	1"	DUE DATE	4-3-96	COMPLETED	
LOCATION	G-9-4	QUANTITY	175	DATE	3-13-96

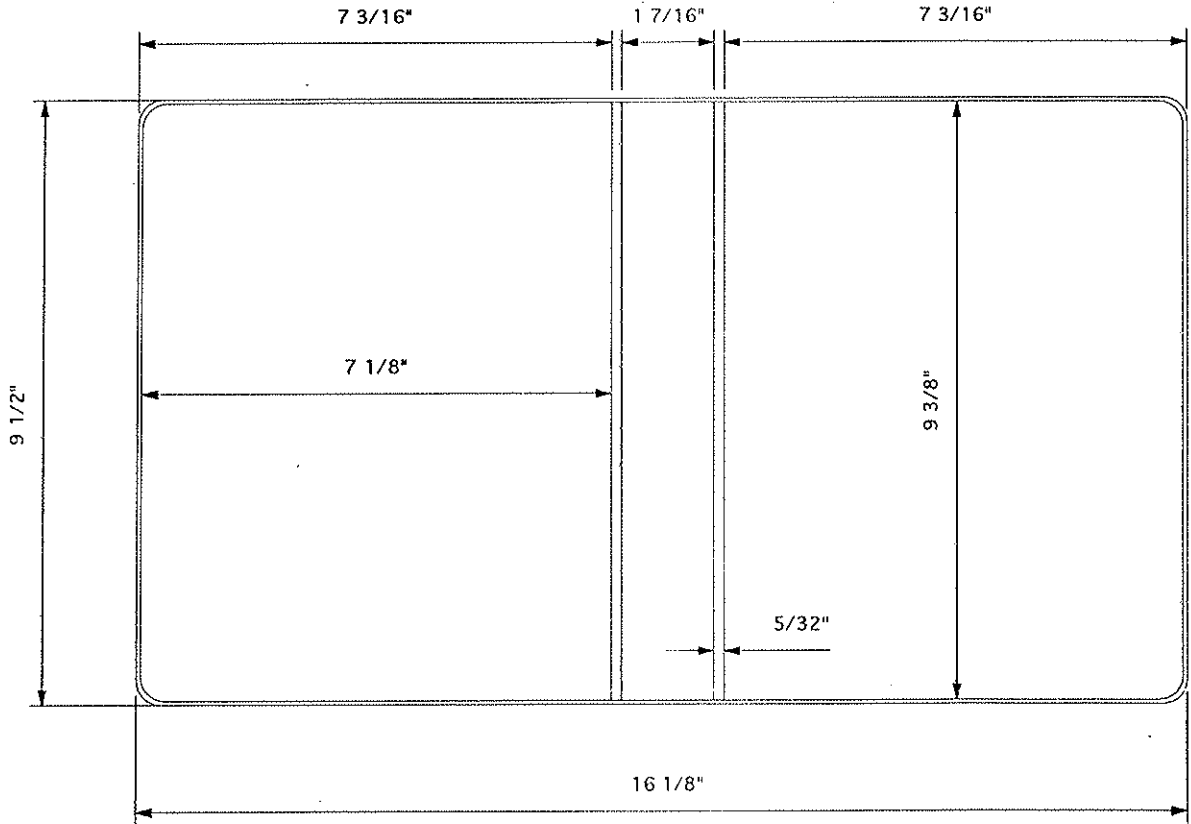

MATERIAL SPECS		GAUGE		PCS.		MATERIAL SPECS		GAUGE	
COVER MAT.	10 1/2 X 17 1/8			1		LINING MAT.			
COVER MAT.						PEN LOOP	1 X 2 1/2		
DIE CUT	11 1/4 X 24 3/4	DIE CUT 6018-B		1		HORZ. PKT.			
COL	PKT. + LINING					VERT. PKT.			
LABEL HOLDER						DIE CUT			
GUSSET						REINF.			

BOARD SPECS		GAUGE		PCS.		BOARD SPECS		GAUGE	
F.C. BOARD						F.C. BOARD			
B.B. BOARD						B.B. BOARD			
B.C. BOARD						B.C. BOARD			
B.U. STRIP						DIE CUT	12 1/8 X 15 9/16	DIE CUT 6018-A	100
DIE CUT						DIE CUT			

DIE #	6142-A	METAL	LOC W/B	RADIUS	3/8"
ORDER #	985745	CUSTOMER	IHI PRINTING	TEAR SEAL	NA
SHEET SIZE		STYLE CASE	VRB	BAR SEAL	178
CAP.	1 1/4"	DUE DATE	11-15-96	COMPLETED	
LOCATION	G-3-3	QUANTITY	10,000	DATE	10-29-96

*Changed to Beaded
Per G.W.M.*

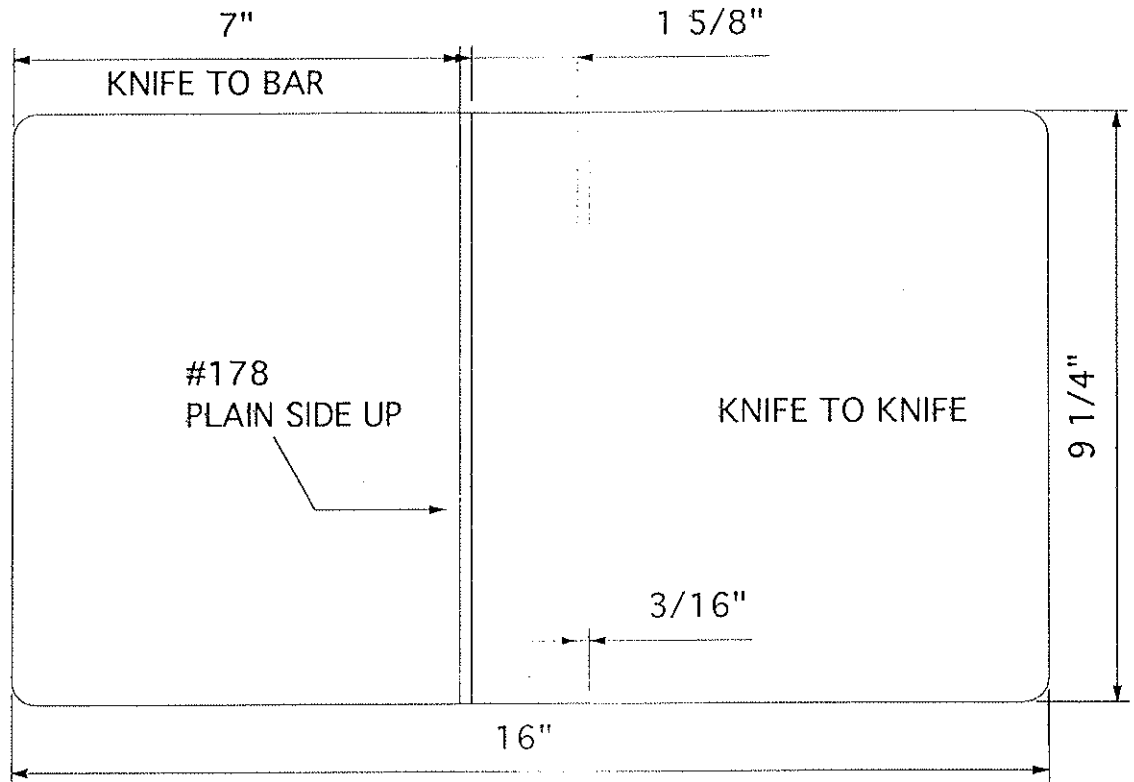

MATERIAL SPECS		GAUGE		PCS.		MATERIAL SPECS		GAUGE	
COVER MAT.	10 1/4 X 17			1	LINING MAT.	10 X 16 3/4			
COVER MAT.					LINING MAT.				
DIE CUT					HORZ. PKT.				
COL					VERT. PKT.				
LABEL HOLDER					DIE CUT				
GUSSET					REINF.				
BOARD SPECS		GAUGE		PCS.		BOARD SPECS		GAUGE	
F.C. BOARD	9 1/8 X 6 7/8	PADDED BD	100	1	F.C. BOARD				
B.B. BOARD	9 1/8 X 1 17/32		100	1	B.B. BOARD	PADDED BD			
B.C. BOARD	9 1/8 X 6 7/8	PADDED BD	100	1	B.C. BOARD				
FLAP BD.					DIE CUT	10 1/8 X 15 1/4	2 OUT		DIECUT 6142-C
BOARD					DIE CUT				

DIE #	6459	METAL	LOC RR	RADIUS	3/8"
ORDER #	989533	CUSTOMER	TYPE A MKTG	TEAR SEAL	NAT EDGE
SHEET SIZE	8 1/2 X 6	STYLE CASE	VINYL BINDER	BAR SEAL	253
CAP.	1 1/2"	DUE DATE	4-1-98	COMPLETED	
LOCATION		QUANTITY	750	DATE	3-19-98

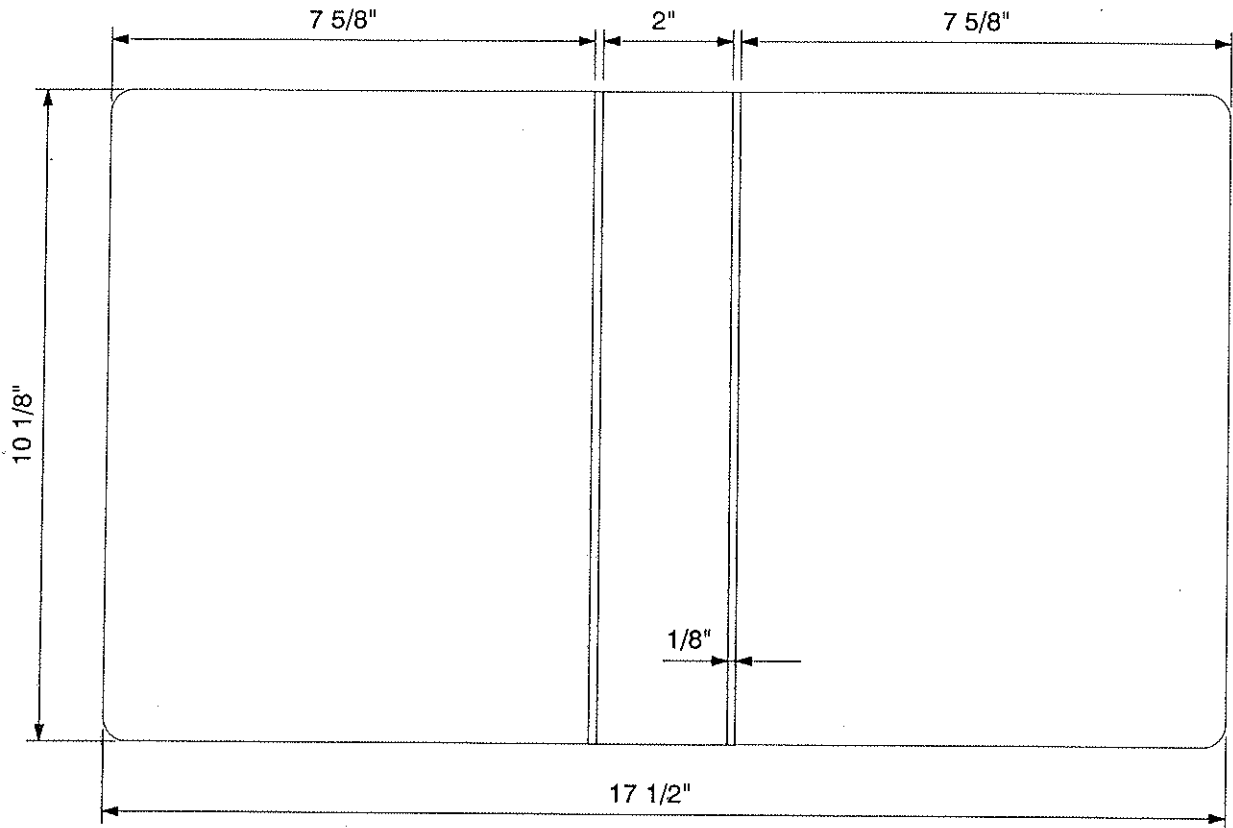

MATERIAL SPECS		GAUGE		PCS.		MATERIAL SPECS		GAUGE		PCS.	
COVER MAT.	10 7/8 X 18 1/4			1		LINING MAT.	10 7/8 X 18 1/4			1	
COVER MAT.						LINING MAT.					
DIE CUT						HORZ. PKT.	4 3/8 X 18 1/4			1	
COL						VERT. PKT.					
LABEL HOLDER						DIE CUT					
GUSSET						REINF.					

BOARD SPECS		GAUGE		PCS.		BOARD SPECS		GAUGE		PCS.	
F.C. BOARD	10 X 7 1/2	100	1	F.C. BOARD							
B.B. BOARD	10 X 1 29/32	100	1	B.B. BOARD							
B.C. BOARD	10 X 7 1/2	100	1	B.C. BOARD							
FLAP BD.				DIE CUT							
BOARD				DIE CUT							

DIE #	6785 1up	METAL	LOC PRONG METAL	RADIUS	3/8"
ORDER #	280891	CUSTOMER	AT-A-GLANCE GROUP	TEAR SEAL	.010
SHEET SIZE	8.25 X 6.25	STYLE CASE	VINYL RING BINDER	BAR SEAL	FLAT
CAP.	1"	DUE DATE	3-20-99	COMPLETED	
LOCATION		QUANTITY	1	DATE	10-20-99

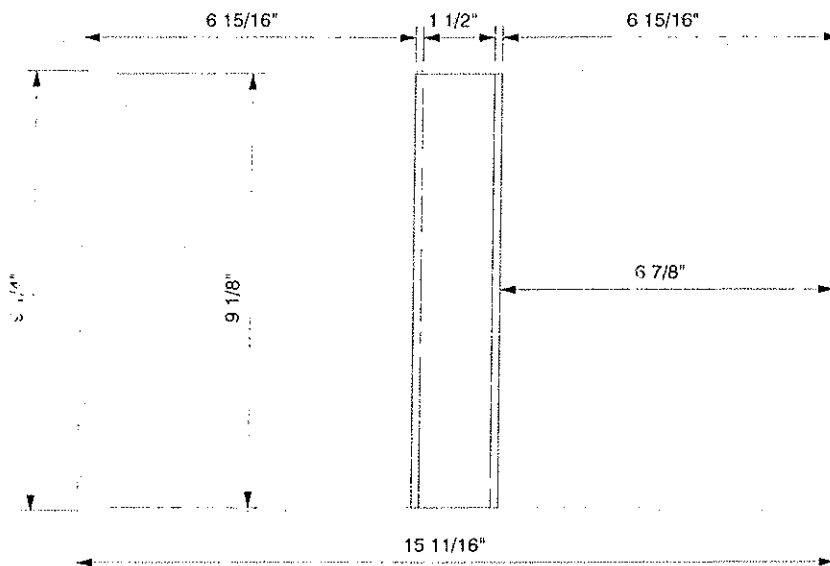

MATERIAL SPECS		GAUGE	PCS.	MATERIAL SPECS		GAUGE	PCS.
COVER MAT.	10 X 16 11/16		1	LINING MAT.	10 X 16 11/16		1
PICTORIAL				LINING MAT.			
LABEL HOLDER				HORZ. PKT.			
COL				HORZ. PKT.			
EX COL NO TRIM				ONE SIDED			
EX COL				ONE SIDED			

NORMAL 1/16" TOL.		5/16" R. CORNERS	PCS.	BOARD TOL. (3/32")	5/16" R. CORNERS	PCS.
F.C. BOARD	9 1/16 X 6 13/16		1	F.C. BOARD		
B.B. BOARD	9 1/16 X 1 13/32		1	B.B. BOARD		
B.C. BOARD	9 1/16 X 6 13/16		1	B.C. BOARD		
FLAP BD.				DIE CUT		

7214	METAL	LOC	RADIUS	3/8"
ER # 477108	CUSTOMER	EBSCO MEDIA	TEAR SEAL	.012
ET SIZE 8 1/2 X 6	STYLE CASE	VRB MATCHED CUST SAMPLE	BAR SEAL	48-3
1 1/2"	DUE DATE	2-4-02	COMPLETED	
ATION	QUANTITY	1	DATE	1-31-02

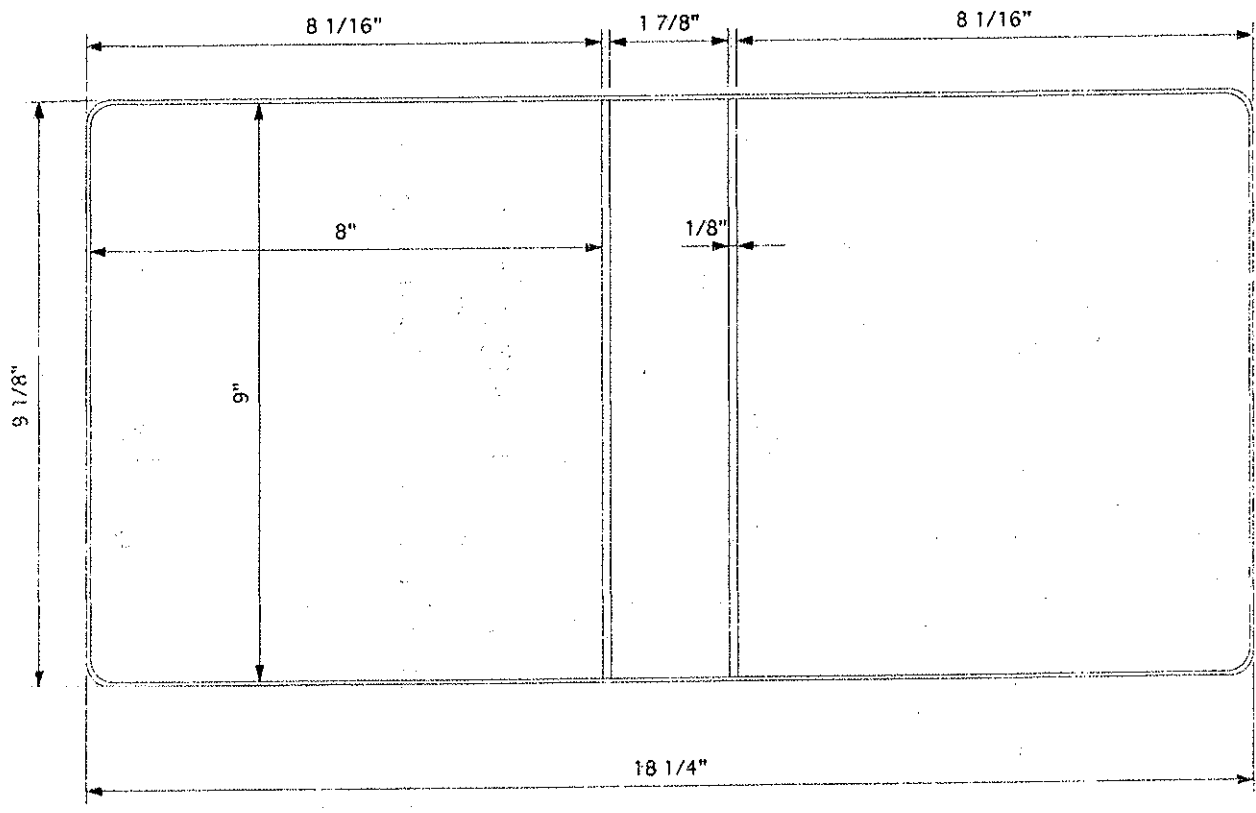

MATERIAL SPECS	GAUGE	PCS.	MATERIAL SPECS	GAUGE	PCS.		
COVER MAT.	9 7/8 X 19	1	LINING MAT.	9 7/8 X 19	1		
COVER MAT.			LINING MAT.				
CUT			HORZ. PKT.	4 3/8 X 8 9/16	1		
			VERT. PKT.				
REL HOLDER			DIE CUT				
ASSET			REINF.				
BOARD SPECS	5/16" R. CORNERS	GAUGE	PCS.	BOARD SPECS	5/16" R. CORNERS	GAUGE	PCS.
F.C. BOARD	8 15/16 X 7 15/16	100	1	F.C. BOARD			
B.B. BOARD	8 15/16 X 1 25/32	100	1	B.B. BOARD			
B.C. BOARD	8 15/16 X 7 15/16	100	1	B.C. BOARD			
IP BD.				DIE CUT			
ARD				DIE CUT			

DIE #	7281	METAL	ROUND RING	RADIUS	1/4"
ORDER #	505236	CUSTOMER	EBSCO MEDIA	TEAR SEAL	.012
SHEET SIZE	8 1/2 X 6 1/2	STYLE CASE	VINYL BINDER	BAR SEAL	48-4
CAP.	1"	DUE DATE	8-12-02	COMPLETED	
LOCATION		QUANTITY	500	DATE	7-22-02

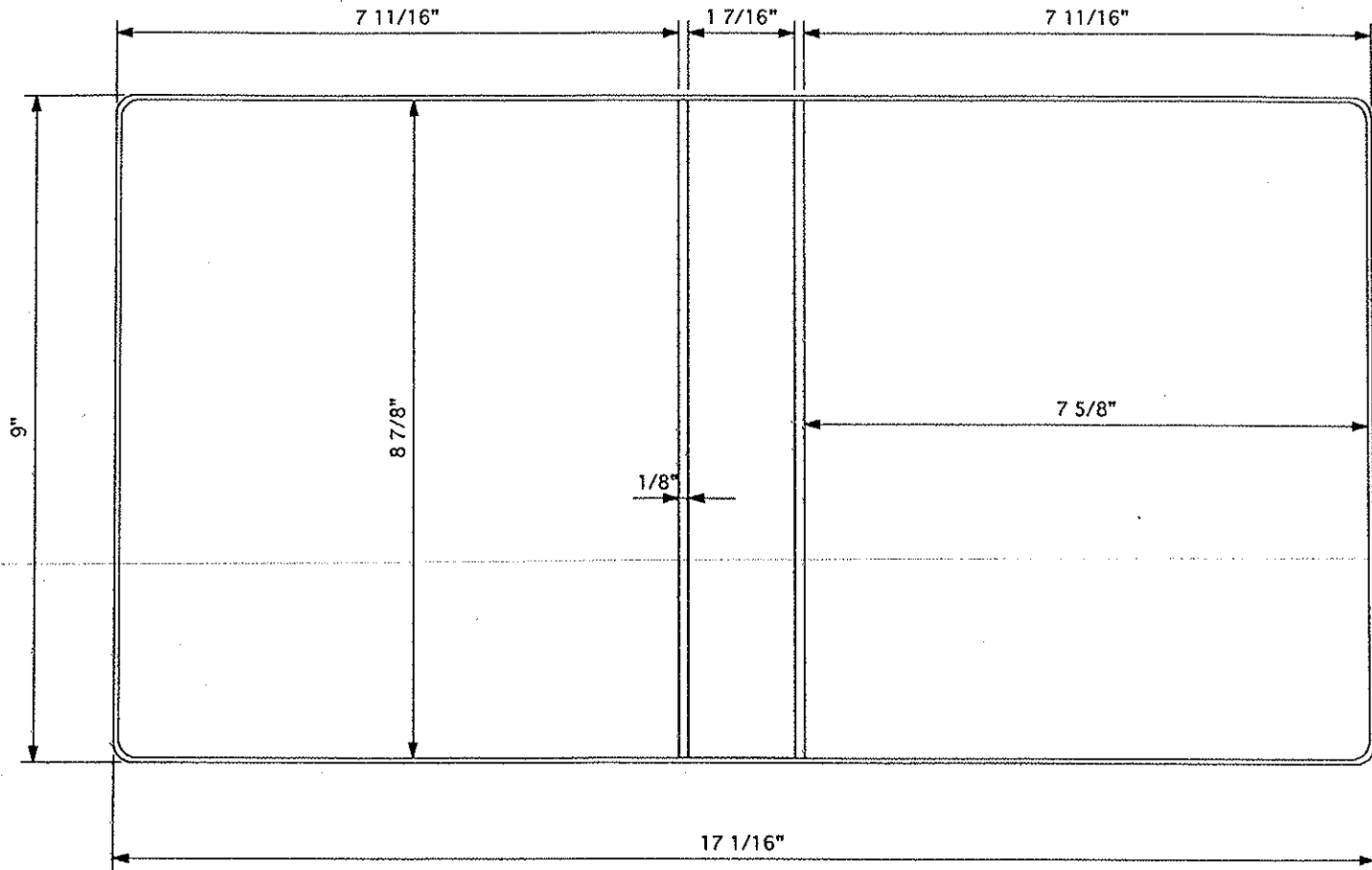

MATERIAL SPECS		GAUGE	PCS.	MATERIAL SPECS		GAUGE	PCS.				
COVER MAT.	9 3/4 X 17 13/16		1	LINING MAT.	9 3/4 X 17 13/16		1				
COVER MAT.	9 3/4 X 17 13/16		1	LINING MAT.							
DIE CUT				HORZ. PKT.	4 3/8 X 17 13/16		1				
COL				VERT. PKT.							
LABEL HOLDER				DIE CUT							
GUSSET				REINF.							
BOARD SPECS		5/16" R. CORNERS		GAUGE	PCS.	BOARD SPECS		5/16" R. CORNERS		GAUGE	PCS.
F.C. BOARD	8 13/16 X 7 9/16	100	1	F.C. BOARD							
B.B. BOARD	8 13/16 X 1 11/32	100	1	B.B. BOARD							
B.C. BOARD	8 13/16 X 7 9/16	100	1	B.C. BOARD							
FLAP BD.				DIE CUT							
BOARD	8 25/32 X 1 5/16	22	1	DIE CUT							

DIE #	7282	METAL	HOC	RADIUS	3/8"
ORDER #	504831	CUSTOMER	NSC	TEAR SEAL	.014
SHEET SIZE	8 1/2 X 6	STYLE CASE	VINYL BINDER	BAR SEAL	48-4
CAP.	2"	DUE DATE	7-30-02	COMPLETED	
LOCATION		QUANTITY	9306	DATE	7-22-02

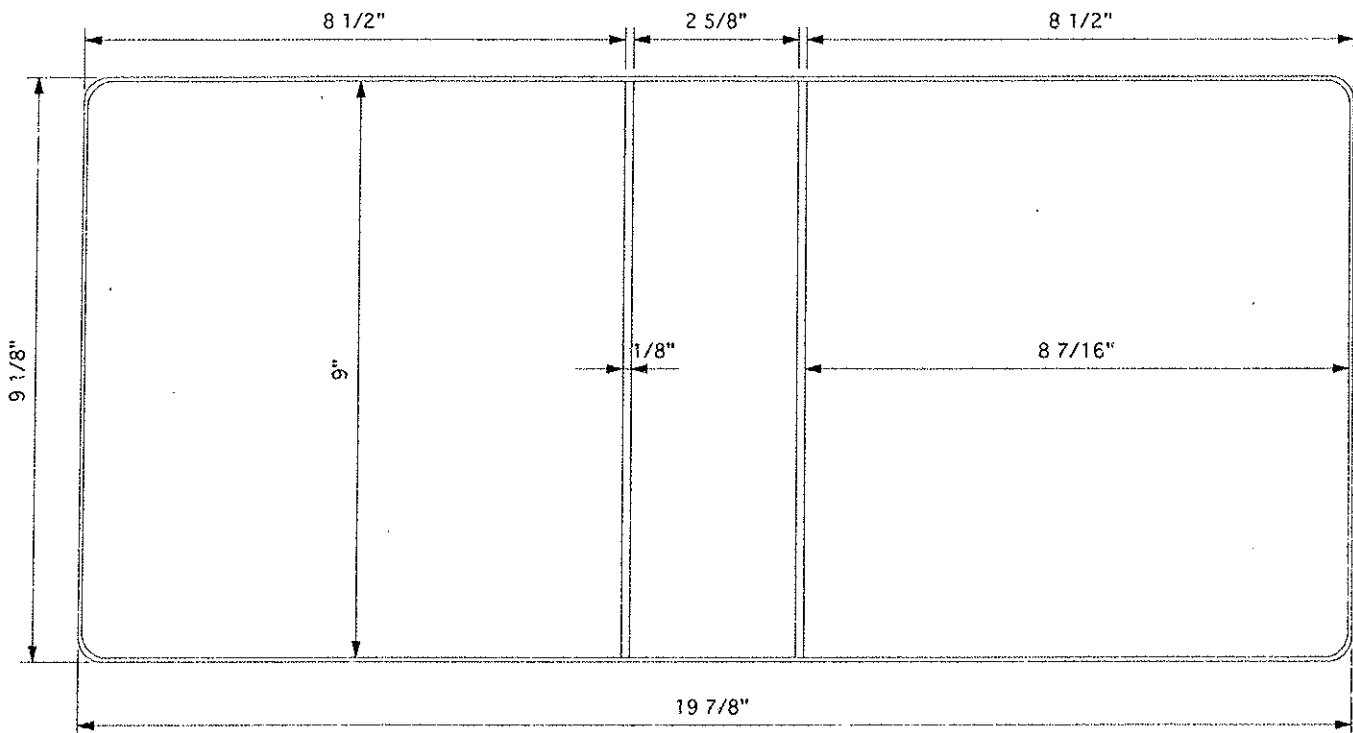

MATERIAL SPECS		GAUGE	PCS.	MATERIAL SPECS		GAUGE	PCS.		
COVER MAT.	9 7/8 X 20 5/8		1	LINING MAT.	9 7/8 X 20 5/8		1		
COVER MAT.	9 7/8 X 20 5/8		1	LINING MAT.					
DIE CUT				HORZ. PKT.	4 3/8 X 20 5/8		1		
COL				VERT. PKT.					
LABEL HOLDER				DIE CUT					
GUSSET				REINF.					
BOARD SPECS		5/16" R. CORNERS	GAUGE	PCS.	BOARD SPECS		5/16" R. CORNERS	GAUGE	PCS.
F.C. BOARD	8 15/16 X 8 3/8		120	1	F.C. BOARD				
B.B. BOARD	8 15/16 X 2 17/32		120	1	B.B. BOARD				
B.C. BOARD	8 15/16 X 8 3/8		120	1	B.C. BOARD				
FLAP BD.					DIE CUT				
BOARD					DIE CUT				

DIE #	7459-R	METAL	LOC RR	RADIUS	3/8"
ORDER #	558813	CUSTOMER	MICRO IMAGES INC	TEAR SEAL	
SHEET SIZE	8 1/2 X 6	STYLE CASE	VINYL BINDER (NELL)	BAR SEAL	
CAP.	1 1/2"	DUE DATE	6-17-03	COMPLETED	
LOCATION		QUANTITY	500	DATE	6-3-03

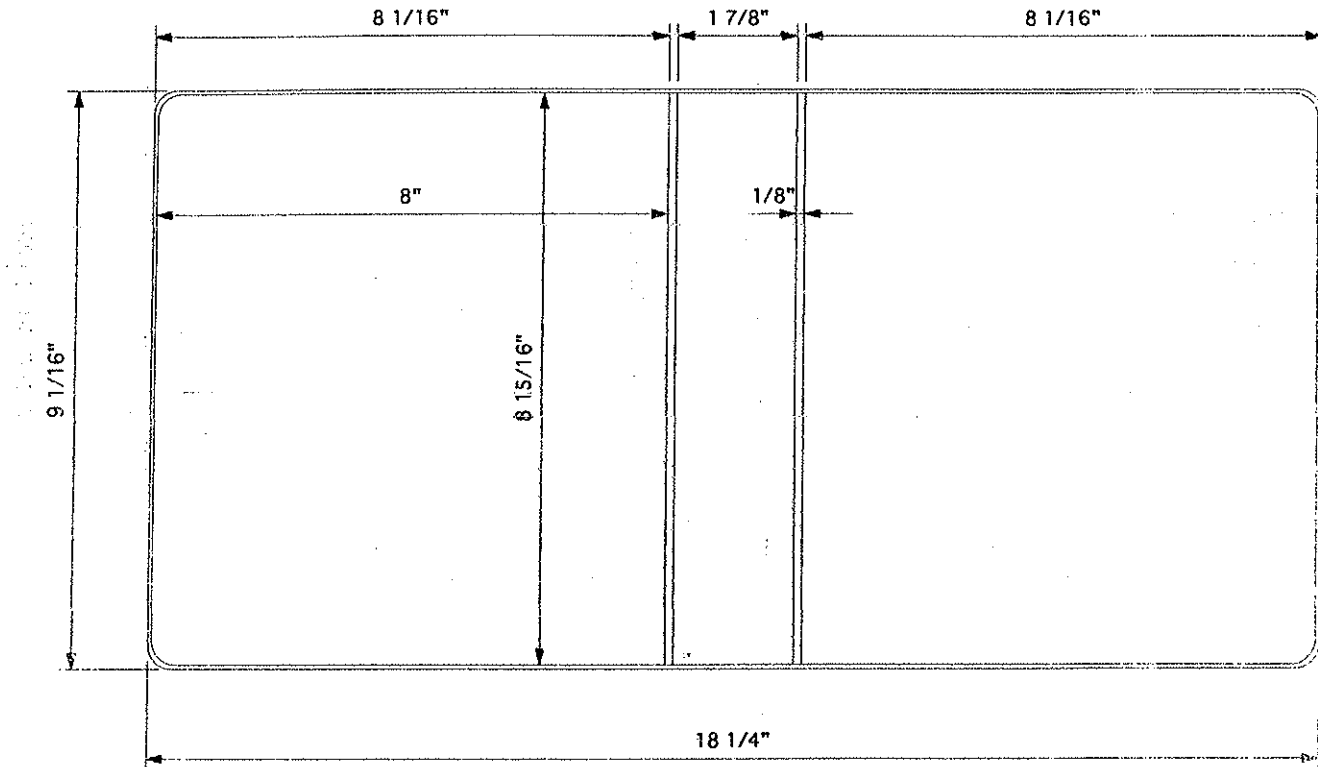

MATERIAL SPECS		GAUGE	PCS.	MATERIAL SPECS		GAUGE	PCS.		
COVER MAT.	9 13/16 X 19		1	LINING MAT.	9 13/16 X 19		1		
COVER MAT.				LINING MAT.					
DIE CUT				HORZ. PKT.					
COL	9 3/16 X 19		1	VERT. PKT.					
LABEL HOLDER				DIE CUT					
GUSSET				REINF.					
BOARD SPECS		5/16" B. CORNERS	GAUGE	PCS.	BOARD SPECS		5/16" B. CORNERS	GAUGE	PCS.
F.C. BOARD	8 7/8 X 7 15/16		100	1	F.C. BOARD				
B.B. BOARD	8 7/8 X 1 25/32		100	1	B.B. BOARD				
B.C. BOARD	8 7/8 X 7 15/16		100	1	B.C. BOARD				
FLAP BD.					DIE CUT				
BOARD	8 27/32 X 1 25/32		35	1	DIE CUT				

DIE #	7512	METAL	LOC	RADIUS	1/4"
ORDER #	568472	CUSTOMER	RADIUS GROUP SHIPMATES		TEAR SEAL
SHEET SIZE	8 1/2 X 6	STYLE CASE	VINYL RING BINDER (NELL)		BAR SEAL
CAP.	3/4"	DUE DATE	8-22-03	COMPLETED	
LOCATION		QUANTITY	120	DATE	8-14-03

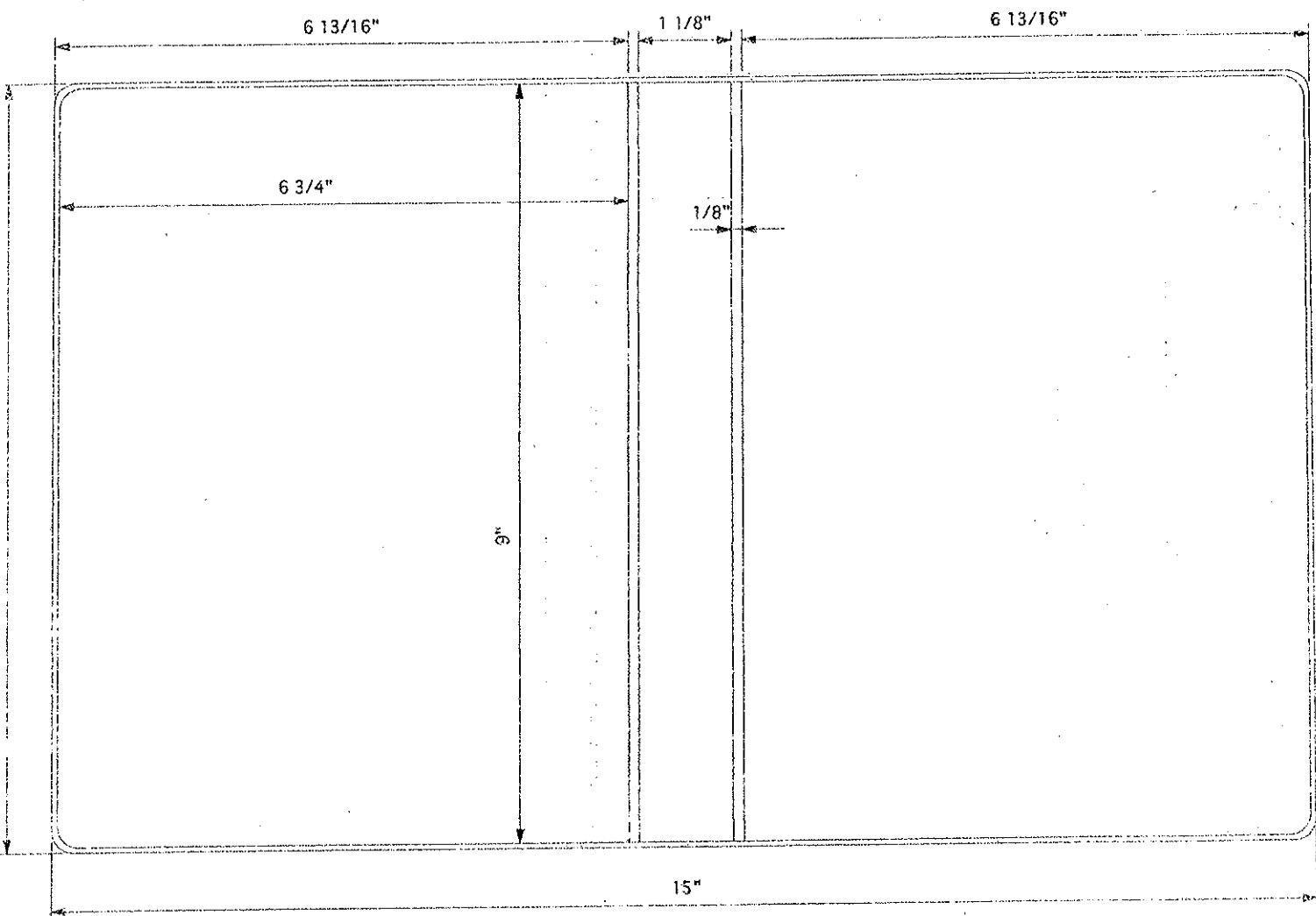

MATERIAL SPECS		GAUGE	PCS.	MATERIAL SPECS	GAUGE	PCS.
COVER MAT.	9 7/8 X 15 3/4		1	LINING MAT.	9 7/8 X 15 3/4	1
COVER MAT.				LINING MAT.		
DIE CUT				HORZ. PKT.		
COL				VERT. PKT.		
LABEL HOLDER				DIE CUT		
GUSSET				REINF.		
BOARD SPECS		GAUGE	PCS.	BOARD SPECS	GAUGE	PCS.
F.C. BOARD	8 29/32 X 6 21/32	100	1	F.C. BOARD	5/16" R. CORNERS	
B.B. BOARD	8 29/32 X 1	100	1	B.B. BOARD		
B.C. BOARD	8 29/32 X 6 21/32	100	1	B.C. BOARD		
FLAP BD.				DIE CUT		
BOARD				DIE CUT		

DIE #	7641	METAL	LOC	RADIUS	3/8"
ORDER #	604277	CUSTOMER	AIRBORNE EXPRESS	TEAR SEAL	.014
SHEET SIZE	8 1/2 X 6	STYLE CASE	VINYL BINDER	BAR SEAL	48-4
CAP.	1/2"	DUE DATE	2-28-04	COMPLETED	
LOCATION		QUANTITY	50	DATE	4-24-04

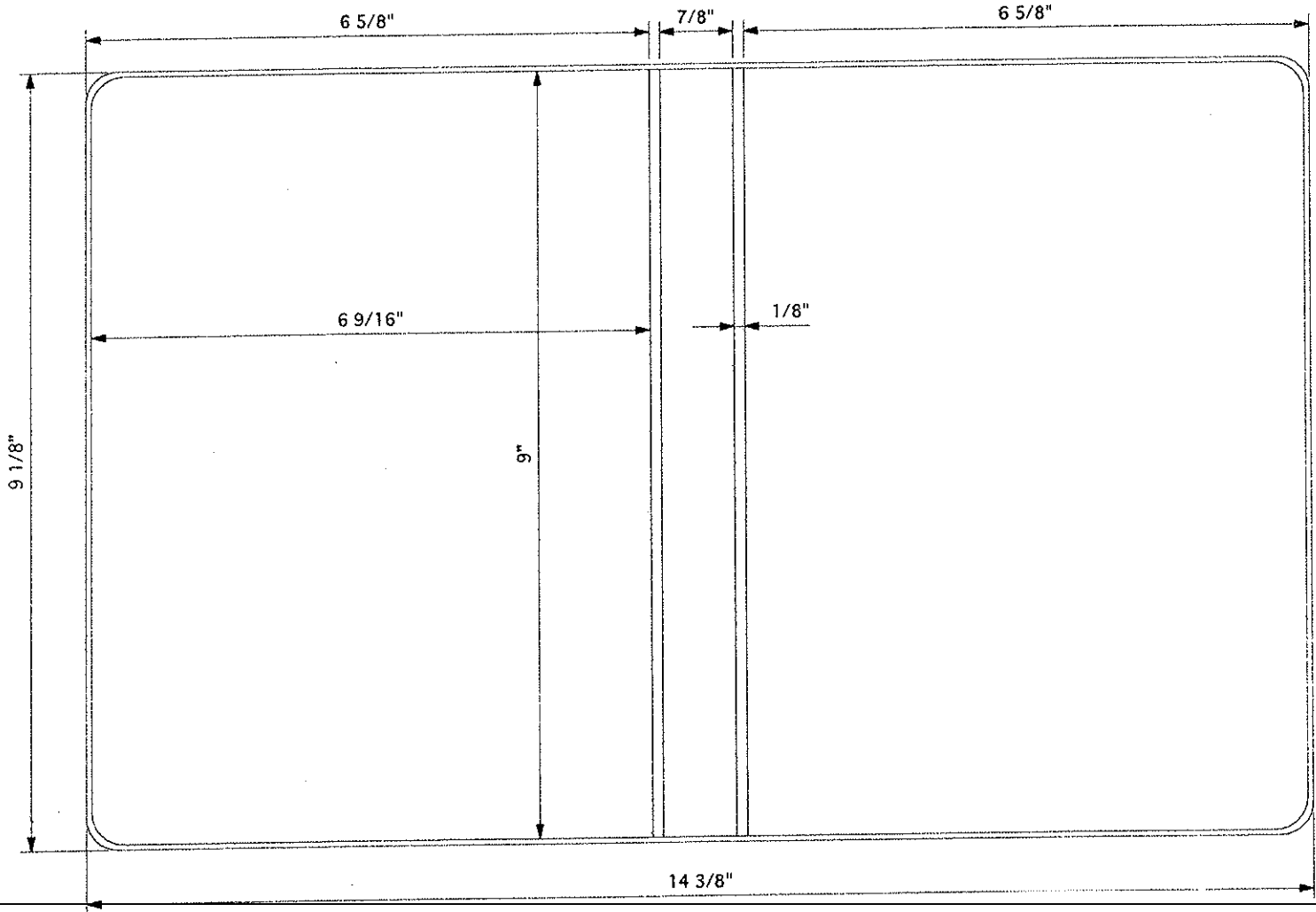

MATERIAL SPECS		GAUGE	PCS.	MATERIAL SPECS		GAUGE	PCS.
COVER MAT.	9 7/8 X 15 1/8	1		LINING MAT.	9 7/8 X 15 1/8	1	
COVER MAT.				LINING MAT.			
DIE CUT				HORZ. PKT.			
COL	9 1/4 X 8 1/2	1		VERT. PKT.			
LABEL HOLDER				DIE CUT			
GUSSET				REINF.			

BOARD SPECS	5/16" R. CORNERS	GAUGE	PCS.	BOARD SPECS	5/16" R. CORNERS	GAUGE	PCS.
F.C. BOARD	8 29/32 X 6 15/32	100	1	F.C. BOARD			
B.B. BOARD	8 29/32 X 25/32	100	1	B.B. BOARD			
B.C. BOARD	8 29/32 X 6 15/32	100	1	B.C. BOARD			
FLAP BD.				DIE CUT			
BOARD	8 7/8 X 3/4	35	1	DIE CUT			

DIE #	8337	METAL	ROUND RING	RADIUS	3/8"
ORDER #	792722	CUSTOMER	ADVANCED PRINTING	TEAR SEAL	.014
SHEET SIZE	8 1/2 X 6 5/8	STYLE CASE	VINYL BINDER	BAR SEAL	48-3
CAP.	1/2"	DUE DATE	6-29-07	COMPLETED	
LOCATION		QUANTITY	1000	DATE	6-11-07

*** WARNING DRAWING NOT ACTUAL SIZE ***

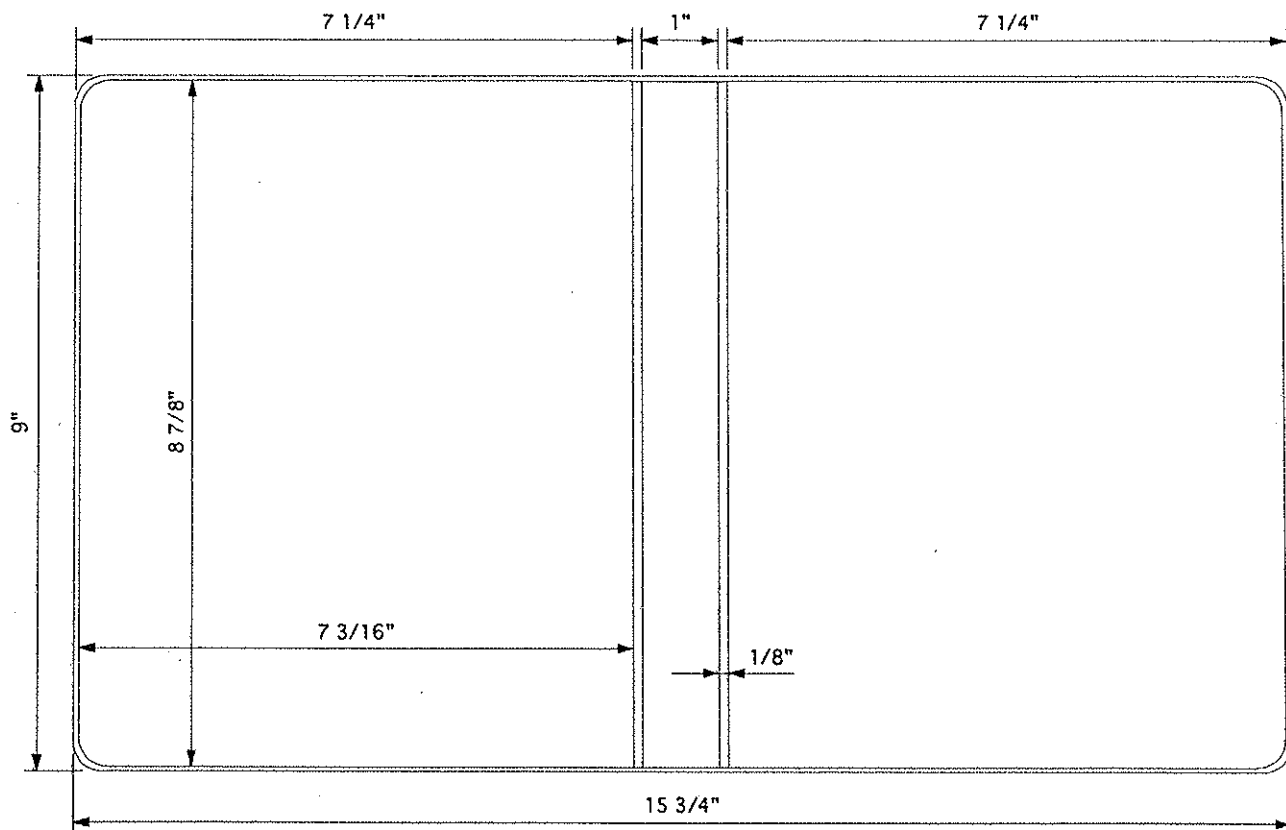

MATERIAL SPECS		GAUGE	PCS.	MATERIAL SPECS		GAUGE	PCS.
COVER MAT.	9 3/4 X 16 1/2		1	LINING MAT.	9 3/4 X 16 1/2		1
COVER MAT.				LINING MAT.			
DIE CUT				HORZ. PKT.	4 3/8 X 7 3/4		1
COL.	9 1/8 X 16 1/2		1	VERT. PKT.			
LABEL HOLDER				DIE CUT			
GUSSET				REINF.			

BOARD SPECS		GAUGE	PCS.	BOARD SPECS		GAUGE	PCS.
5/16" R. CORNERS				5/16" R. CORNERS			
F.C. BOARD	8 25/32 X 7 3/32	98	1	F.C. BOARD			
B.B. BOARD	8 25/32 X 29/32	98	1	B.B. BOARD			
B.C. BOARD	8 25/32 X 7 3/32	98	1	B.C. BOARD			
FLAP BD.				DIE CUT			
BOARD				DIE CUT			