

Product Code

old 871

Style Case Ring Binder

Sheet Size  $9\frac{1}{2}$  X  $6\frac{1}{2}$  Cap.  $\frac{1}{2}$

Die No. 3551

Order No. 952049

Plate

Customer

Assessment Designs

Metal
Total Vinyl 1030
Quantity 50
Date 6-11-86
Type Corners RD
Radius $\frac{1}{4}$
Completed

	Gauge	Thick
Tear Seal	.016	$\frac{3}{32}$
Bar Seal	253	$\frac{1}{8}$
Bar Seal		

	No. of Feet
Tear Seal	
Bar Seal	
Bar Seal	

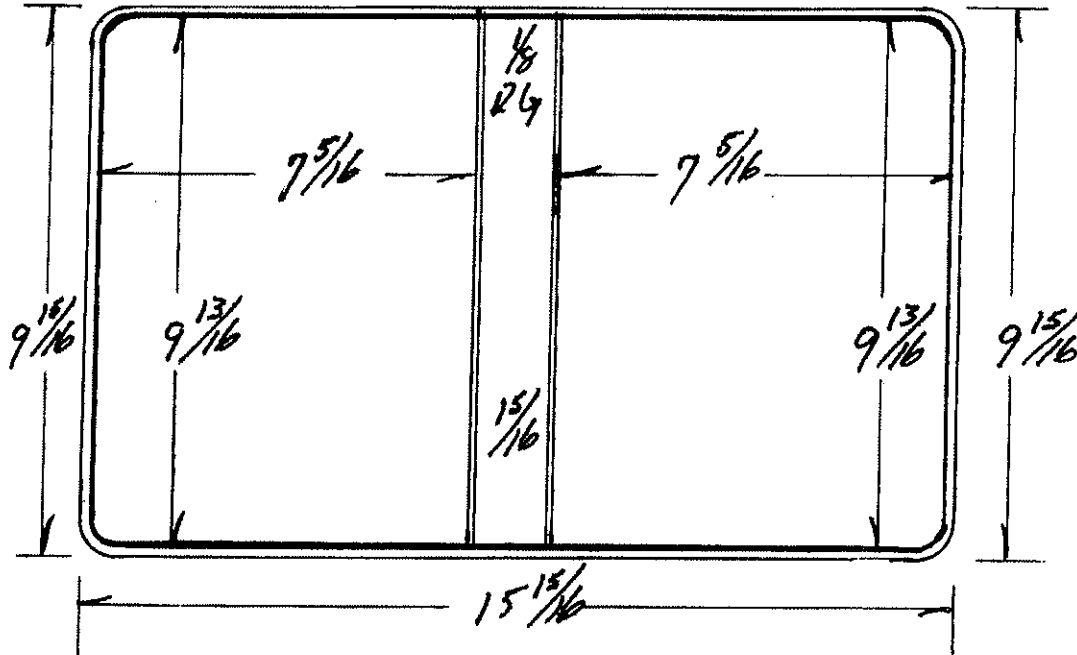

Code	Ga.	PCS	Cutting Specs		Code	Ga.	Pcs.	Cutting Specs	
			Size	Out				Size	Out
Cover Mat.			$10\frac{9}{16}$ X $16\frac{9}{16}$		Lining Mat.			$10\frac{9}{16}$ X $16\frac{9}{16}$	1
Cover Mat			X		Lining Mat.			X	
Vert. Pckt.			X		Horz. Pckt.			X	
Vert. Pckt.			X		Horz. Pckt.			$5\frac{3}{8}$ X $16\frac{9}{16}$	
Pocket			X		Pocket	1-sided		$5\frac{3}{8}$ X $7\frac{7}{8}$	
Label Holder			X		Card Holder			X	
Material			X		Material			X	
Material			X		Material			X	
Material			X		Material			X	
F.C. Board			$9\frac{11}{16}$ X $7\frac{3}{16}$	120 1	B.C. Board			$9\frac{11}{16}$ X $7\frac{3}{16}$	120 1
B.C. Board			$9\frac{3}{4}$ X $7\frac{1}{4}$	100 2	B.B. Board				
Center Board			$9\frac{3}{4}$ X $2\frac{7}{32}$	100 1	Board			$9\frac{11}{16}$ X $2\frac{7}{32}$	120 1
Board			X		Strip			$\lambda$	
Cover Pad			X		Strip			X	
					B.B. Pad			X	

OLD DIE 1391

Product Code

Style Case **VRB**

Sheet Size **9 1/2 x 6 1/2** Cap. **3/4**

Die No. **4144**

Order No. **961787**

Plate

Customer **NAPA**

Metal
Total Vinyl
Quantity
Date
Type Corners
Radius
Completed

	Gauge	Thick
Seal	16	3/32
Seal		
Seal		

	No. of Feet
Seal	
Seal	
Seal	

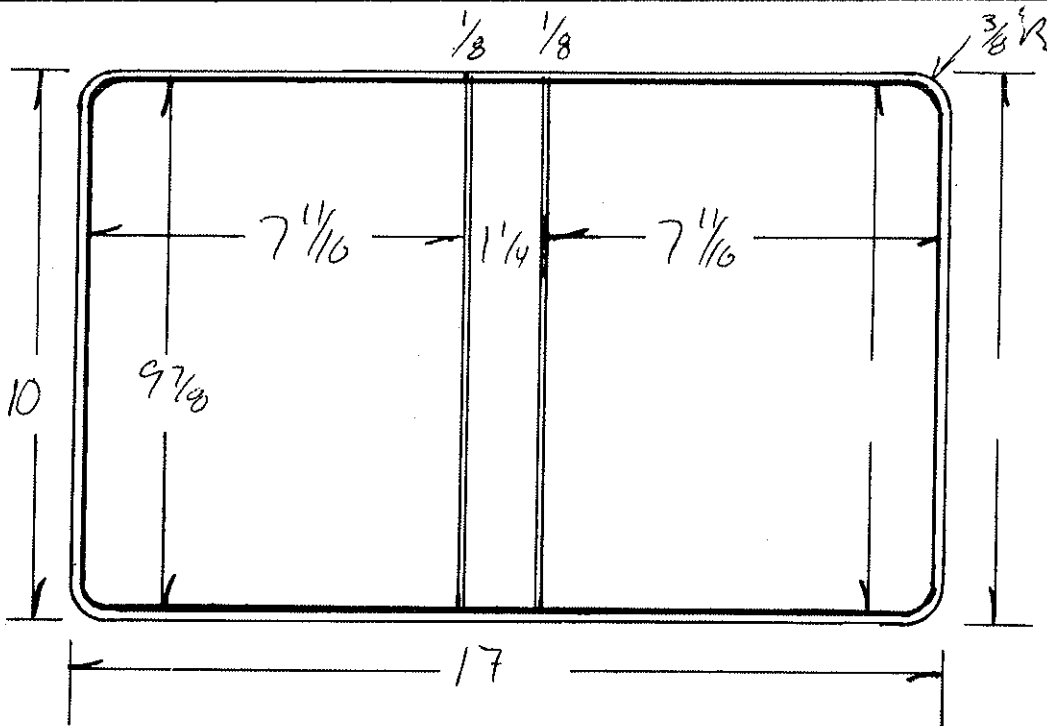

Code	Ga.	#	Cutting Specs		Code	Ga.	#	Cutting Specs	
			Size	Out				Size	Out
cover Mat.			10 3/4	17 3/4	Lining Mat.			10 3/4	17 3/4
cover Mat			X		Lining Mat.			X	
Int. Pckt.			X		Horz. Pckt.			X	
Int. Pckt.			X		Horz. Pckt.			5 3/8	17 3/4
Pocket			X		Pocket	1-sided		5 3/8	8 1/4
Label Holder			X		Card Holder			X	
Material			X		Material			X	
Material			X		Material			X	
Material			X		Material			X	
B.C. Board			9 25/32	7 1/32	B.C. Board			X	
B.C. Board			9 25/32	7 1/32	B.B. Board			9 25/32	1 5/32
Inter Board			9 13/16	7 5/8	Board			X	
Board			1 5/32	9 13/16	Strip			X	
cover Pad			X		Strip			X	
					B.B. Pad			X	

Product Code

OLC # 790

Style Case

VRB

Sheet Size

9 1/2 x 6 1/2

Cap. 1

Die No. 4309

Order No.

Plate

Customer

STOCK.

Metal
Total Vinyl
Quantity
Date
Type Corners
Radius 3/8
Completed 10-24-89 KET

	Gauge	Thick
Tear Seal	.016	1/16
Bar Seal	7-102	3/32
Bar Seal		

	No. of Feet
Tear Seal	
Bar Seal	
Bar Seal	

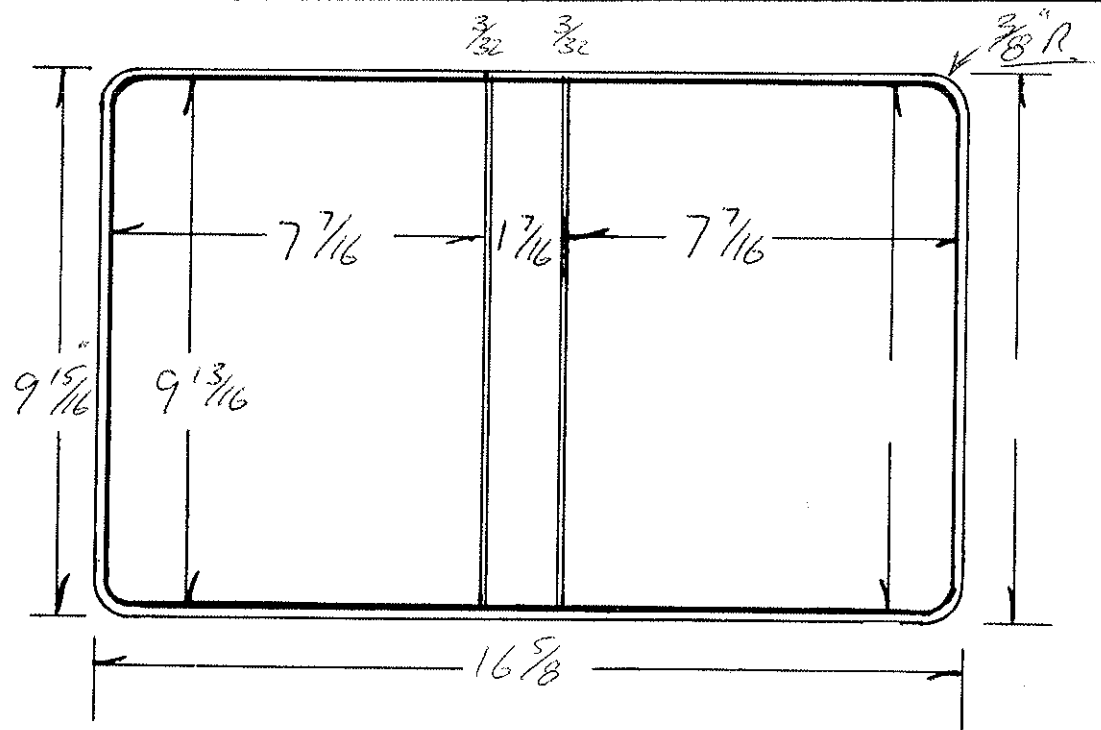

Size By: B.P.

Check By: KP

Code		Ga.	# PCS	Size	Cutting Specs	Out	Code		Ga.	# Pcs.	Size	Cutting Specs	# Out
Cover Mat.	10 3/4 x 17 3/8	15	1				Lining Mat.	10 3/4 x 17 3/8	15	1			
Cover Mat.	X						Lining Mat. 4309-A	11 3/4 x 18 3/8		1			
Vert. Pckt.	X						Horz. Pckt. 1-SID	5 3/8 x 7 15/16		1			
Vert. Pckt.	X						Horz. Pckt. FW1	5 3/8 x 17 3/8					
Pocket	X						Pocket COL	10 1/16 x 17 3/8					
Label Holder	X						Card Holder	X					
Material	X						Material	X					
Material	X						Material	X					
Material	X						Material	X					
B.C. Board	9 23/32 x 7 11/32	120	1				B.C. Board	X					
B.C. Board	9 23/32 x 7 11/32	120	1				B.B. Board	9 23/32 x 1 11/32	120	1			
Center Board	X						Board	X					
Board	9 3/4 x 7 3/8	100	2				Strip	9 3/4 x 1 11/32	100	1			
Cover Pad	X						Strip	X					
							B.B. Pad	X					

Product Code

Style Case 3 Ring

Sheet Size 9 1/2 X 6 1/2 Cap. 1/4 Die No. 2312

Order No. 37501-4

Plate

Customer

Dept. of Adm. Supply Division

Metal
Total Vinyl .030
Quantity 300
Date 4-12-78
Type Corners Rd
Radius 3/8
Completed

	Gauge	Thick
Tear Seal	.012	3/32
Bar Seal	175	3/16
Bar Seal		

	No. of Feet
Tear Seal	4 1/2
Bar Seal	2
Bar Seal	

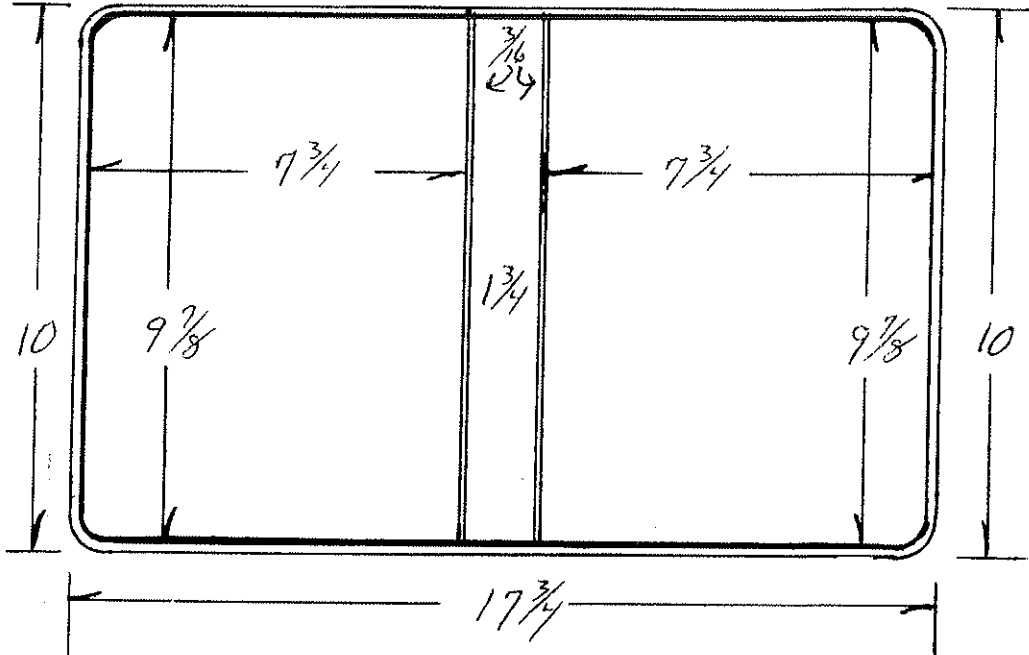

Code	Cutting Specs	Ga.	#	PCS	Size	#	Code	Cutting Specs	Ga.	#	PCS	Size	#	Specs. Min	
														Size	#
Cover Mat.	10 5/8 X 18 3/8			1			Lining Mat.	10 5/8 X 18 3/8			1				
Cover Mat	X						Lining Mat.	X							
Vert. Pckt.	X						Horz. Pckt.	5 3/8 X 18 3/8							
Vert. Pckt.	X						Horz. Pckt 1-sided	5 3/8 X 8 1/4							
Pocket	X						Pocket	X							
Label Holder	X						Card Hlder	X							
Material	X						Material	X							
Material	X						Material	X							
Material	X						Material	X							
F.C. Board	9 25/32 X 7 21/32	100	1				B.C. Board	9 13/16 X 7 11/16	100	1					
B.C. Board	9 25/32 X 7 21/32	100	1				B.B. Board	9 13/16 X 1 21/32	100	1					
Center Board	9 25/32 X 1 21/32	120	1				F.C. Board	9 13/16 X 7 11/16	100	1					
Board	X						Strip	X							
Cover Pad	X						Strip	X							
							B.B. Pad	X							



Product Code

Style Case URB

Sheet Size  $9\frac{1}{2}$  x 6  $\frac{1}{2}$  Cap. 2"

Die No. 853

Order No.

Plate C14-2

Customer
Material
Total Vinyl
Quantity
Date 10-29-92
Type Corners PND
Radius $\frac{3}{8}$
Completed

Gauge	Thick
ear Seal	
ar Seal	
ar Seal	

No. of Feet	
ear Seal	
ar Seal	
ar Seal	

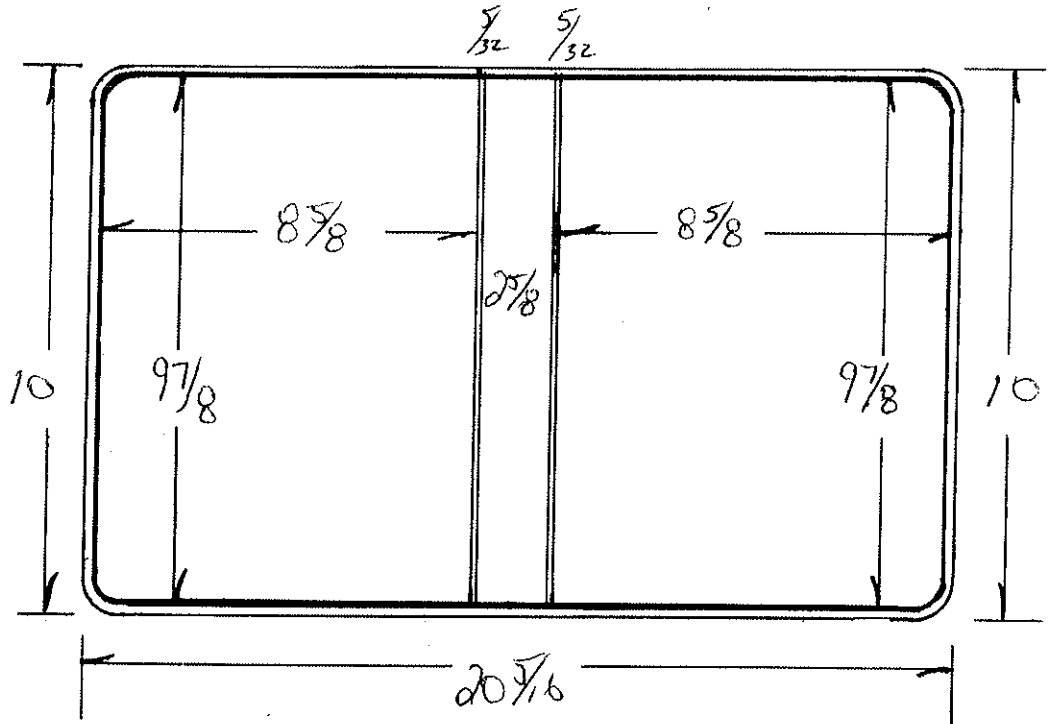

Code	Ga.	# PCS	Cutting Specs		Code	Ga.	# Pcs.	Cutting Specs	
			Size	Out				Size	Out
Over Mat.		1	$10\frac{3}{4}$ X $21\frac{1}{16}$		Lining Mat.		1	$10\frac{3}{4}$ X $21\frac{1}{16}$	
Over Mat.			X		Lining Mat.			X	
Int. Pckt.			X		Horz. Pckt.			$5\frac{3}{8}$ X $21\frac{1}{16}$	
Int. Pckt.			X		Horz. Pckt. 1-sided			$5\frac{3}{8}$ X $9\frac{1}{8}$	
Pocket			X		Pocket			X	
Label Holder			$2\frac{3}{4}$ X 3		Card Holder			X	
Material			X		Material			X	
Material			X		Material			X	
Material			X		Material			X	
C. Board		120	$9\frac{25}{32}$ X $8\frac{17}{32}$	1	B.C. Board	100	1	$9\frac{13}{16}$ X $8\frac{9}{16}$	
C. Board		120	$9\frac{25}{32}$ X $8\frac{17}{32}$	1	B.B. Board	100	1	$9\frac{13}{16}$ X $8\frac{9}{16}$	
Inter Board		120	$9\frac{25}{32}$ X $2\frac{1}{32}$	1	Board	100	1	$9\frac{25}{16}$ X $2\frac{1}{32}$	
Card			X		Strip			X	
Over Pad			X		Strip			X	
					B.B. Pad			X	

Advoc. Advocate D

DIE # 5677		STYLE CASE VINYL RING BINDER		LOCATION ONE-15-4	
SHEET SIZE 9 1/2 X 6 1/2		CAP. 3"		ORDER # 979503	
CUSTOMER INDIANA ADVOCATES				DUE DATE 10-21-94	
QUANTITY	200	RADIUS	3/8	TEAR SEAL	.014
DATE	10-5-94	COMPLETED		BAR SEAL	48-4

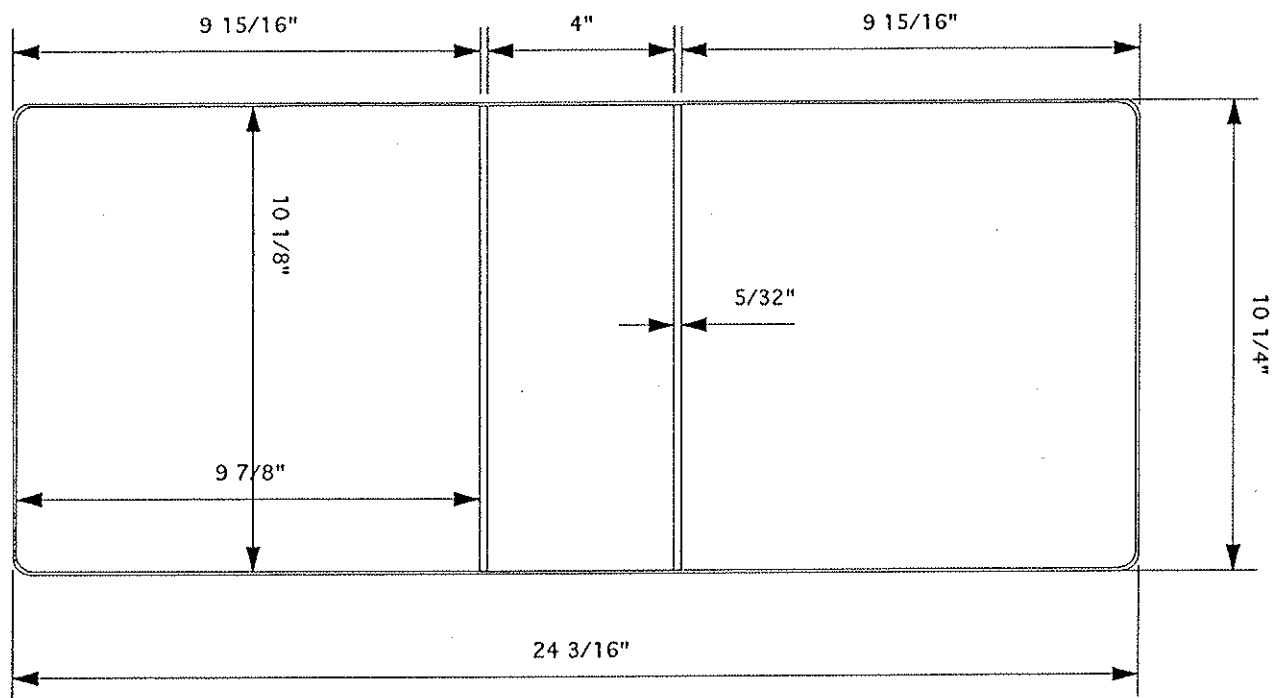

MATERIAL SPECS		GA		PCS	
COVER MATL	11 X 24 15/16	1	LINING	11 X 24 15/16	1
COVER MATL			LINING		
VERT PKT			HORZ PKT		
VERT PKT			HORZPKT		
CARD HOLDER			DIAGONAL PKT		
COL			LABEL HOLDER		
EX COL			GUSSET		
			REINF		

BOARD SPECS					
F.C. BOARD	10 1/32 X 9 25/32	120	1	F.C. BOARD	
B.B. BOARD	10 1/32 X 3 29/32	120	1	B.B. BOARD	
B.C. BOARD	10 1/32 X 9 25/32	120	1	B.C. BOARD	
BU STRIP					