

Product Code

old 1169

Style Case

Easel

Sheet Size 11 X 9

Cap. 1 1/4

Die No. 3647

Order No.

Plate

Customer

Metal
Total Vinyl .030
Quantity
Date
Type Corners R2
Radius 1/4
Completed

	Gauge	Thick
Tear Seal	.016	3/32
Bar Seal	178	3/16
Bar Seal		

	No. of Feet
Tear Seal	
Bar Seal	
Bar Seal	

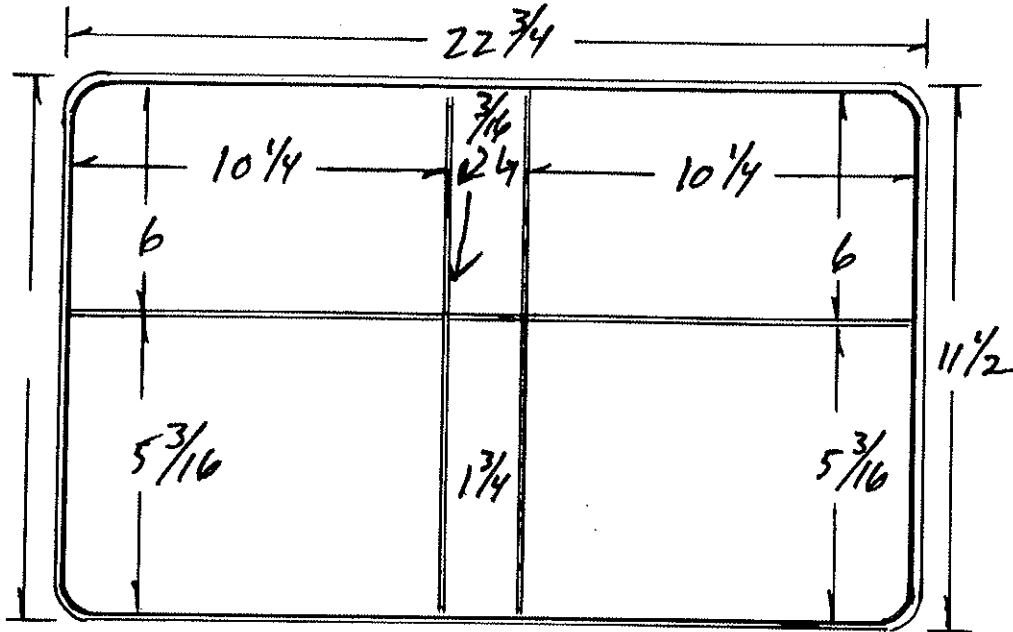

Code		Cutting Specs		Code		Cutting Specs			
		Ga.	# PCS	Size	Out	Ga.	# Pcs.	Size	Out
Cover Mat.	12 1/8 X 23 1/2		1			Lining Mat.	12 1/8 X 23 1/2		1
Cover Mat	X					Lining Mat.	X		
Vert. Pckt.	X					Horz. Pckt. <i>Strap</i>	9 X 2 1/2		
Vert. Pckt.	X					Horz. Pckt.	X		
Pocket	X					Pocket	X		
Label Holder	X					Card Hlder	X		
Material	X					Material	X		
Material	X					Material	X		
Material	X					Material	X		
F.C. Board	5 3/8 X 10 7/32	100	2			B.C. Board	X		
B.C. Board	5 3/8 X 10 7/32	100	2			B.B. Board	5 3/8 X 1 1/2	100	1
Center Board	FC 5 7/8 X 10 1/8	120	2			Board	5 3/8 X 1 7/32	100	1
Board	BC 5 1/16 X 10 1/8	120	2			Strip	BB 5 7/8 X 1 5/8	120	1
Cover Pad	X					Strip	BB 5 1/16 X 1 5/8	120	1
						B.B. Pad	X		

Product Code _____

Style Case Split Back Easel

Sheet Size 8 1/2 X 6 5/8 Cap. 1

Die No. 3749

Order No. 954575 Plate _____

Customer

Inst. of Industrial Engineers

Metal
Total Vinyl <u>.030</u>
Quantity <u>300</u>
Date <u>2-20-87</u>
Type Corners <u>RD</u>
Radius <u>1/4</u>
Completed

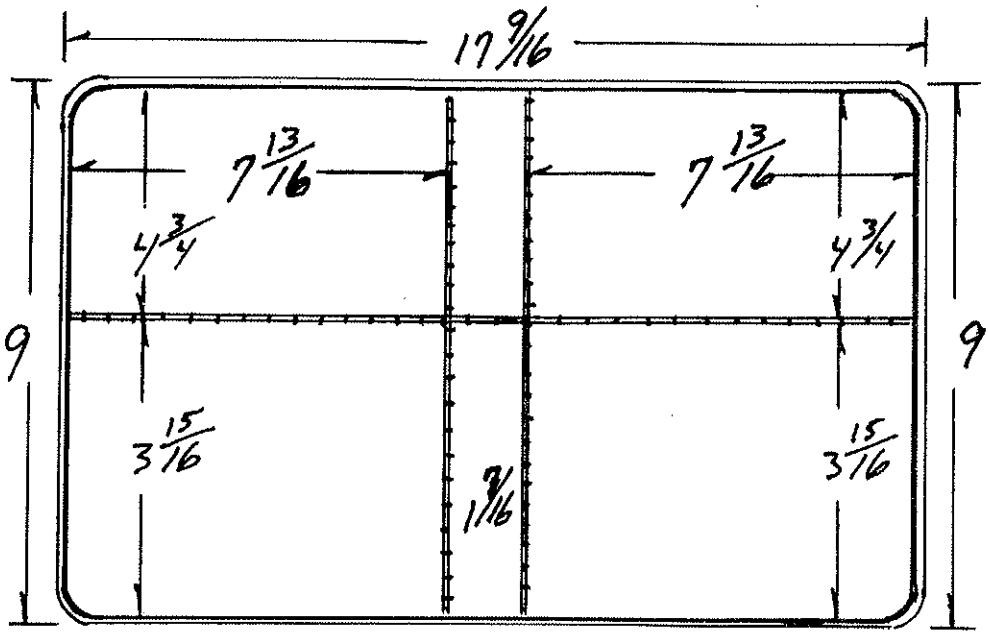

	Gauge	Thick
Tear Seal	<u>.016</u>	<u>3/32</u>
Bar Seal	<u>89 D.5</u>	<u>4.000</u>
Bar Seal		

	No. of Feet
Tear Seal	
Bar Seal	
Bar Seal	

Mill Brass
Down .010

Code	Ga.	PCS	Cutting Specs		Code	Ga.	Pcs.	Cutting Specs	
			Size	Out				Size	Out
Cover Mat.		<u>1</u>	<u>9 5/8 X 18 5/16</u>		Lining Mat.		<u>1</u>	<u>9 5/8 X 18 5/16</u>	
Cover Mat.			X		Lining Mat.			X	
Vert. Pckt.	<u>Strap</u>		<u>9 X 2 1/2</u>		Horz. Pckt.			X	
Vert. Pckt.			X		Horz. Pckt.			X	
Pocket			X		Pocket			X	
Label Holder		<u>1</u>	<u>4 11/16 X 1 13/16</u>		Card Holder			X	
Material			X		Material			X	
Material			X		Material			X	
Material			X		Material			X	
F.C. Board		<u>2</u>	<u>4 1/2 X 7 1/2</u>	<u>100</u>	B.C. Board	<u>FC</u>	<u>2</u>	<u>4 5/8 X 7 11/16</u>	<u>100</u>
B.C. Board		<u>2</u>	<u>3 1/2 X 7 1/2</u>	<u>100</u>	B.B. Board	<u>BC</u>	<u>2</u>	<u>3 13/16 X 7 11/16</u>	<u>100</u>
Center Board		<u>1</u>	<u>4 1/2 X 1 1/2</u>	<u>100</u>	Board	<u>BB</u>	<u>1</u>	<u>4 5/8 X 1 5/16</u>	<u>120</u>
Board		<u>1</u>	<u>3 1/2 X 1 1/2</u>	<u>100</u>	Strip	<u>BB</u>	<u>120</u>	<u>3 13/16 X 1 5/16</u>	<u>120</u>
Cover Pad			X		Strip			X	
					B.B. Pad			X	

Product Code

Style Case *Split back Ensel*

Sheet Size $8\frac{1}{2}$ X 6

Cap. 1

Die No. 3842

Order No. 955959

Plate

Customer

Inter leaf

Metal
Total Vinyl <i>030</i>
Quantity <i>1000</i>
Date
Type Corners <i>Rd</i>
Radius <i>1/4</i>
Completed

	Gauge	Thick
Tear Seal	<i>Blind</i>	<i>edge 8/16</i>
Bar Seal	<i>77</i>	<i>6 m.m.</i>
Bar Seal		

	No. of Feet
Tear Seal	
Bar Seal	
Bar Seal	

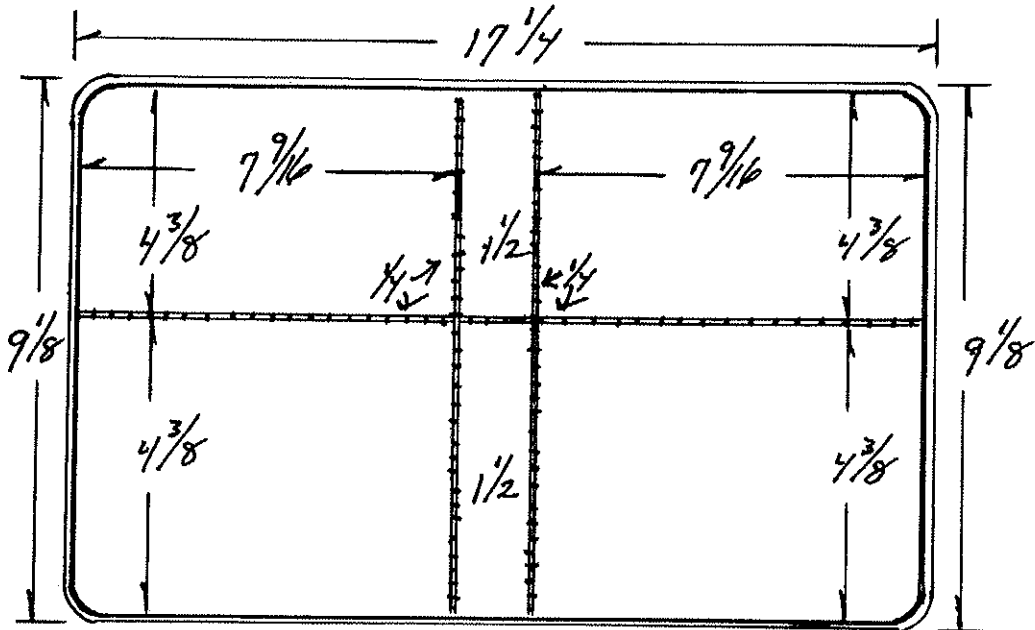

Die being made outside

Code		Ga.	PCS	Size	Out	Cutting Specs	Code		Ga.	PCS	Size	Out	Cutting Specs
Cover Mat.	$9\frac{3}{4}$ X 18		1				Lining Mat.	$9\frac{3}{4}$ X 18		1			
Cover Mat	X						Lining Mat.	X					
Vert. Pckt.	<i>Strap</i> 9 X $2\frac{1}{2}$						Horz. Pckt.	X					
Vert. Rckt.	X						Horz. Pckt.	X					
Pocket	X						Pocket	X					
Label Holder	3 X $1\frac{7}{8}$		1				Card Holder	X					
Material	X						Material	X					
Material	X						Material	X					
Material	X						Material	X					
F.C. Board	$4\frac{9}{32}$ X $7\frac{15}{32}$	100	2				B.C. Board	$4\frac{7}{16}$ X $7\frac{1}{2}$	100	2			
B.C. Board	$4\frac{9}{32}$ X $1\frac{13}{32}$	120	2				B.B. Board	$4\frac{9}{32}$ X $1\frac{13}{32}$	100	2			
Center Board	$4\frac{9}{32}$ X $7\frac{15}{32}$	120	2				Board	BB $4\frac{1}{4}$ X $1\frac{3}{8}$	120	2			
Board							Strip	X					
Cover Pad	X						Strip	X					
							B.B. Pad	X					

old vic 122

Product Code

Style Case SPLIT Back Easel

Sheet Size 11 x 9

Cap. 2

Die No. 4022

Order No. 958829

Plate

Customer

Metal
Total Vinyl
Quantity
Date
Type Corners <u>RD</u>
Radius <u>1/4</u>
Completed

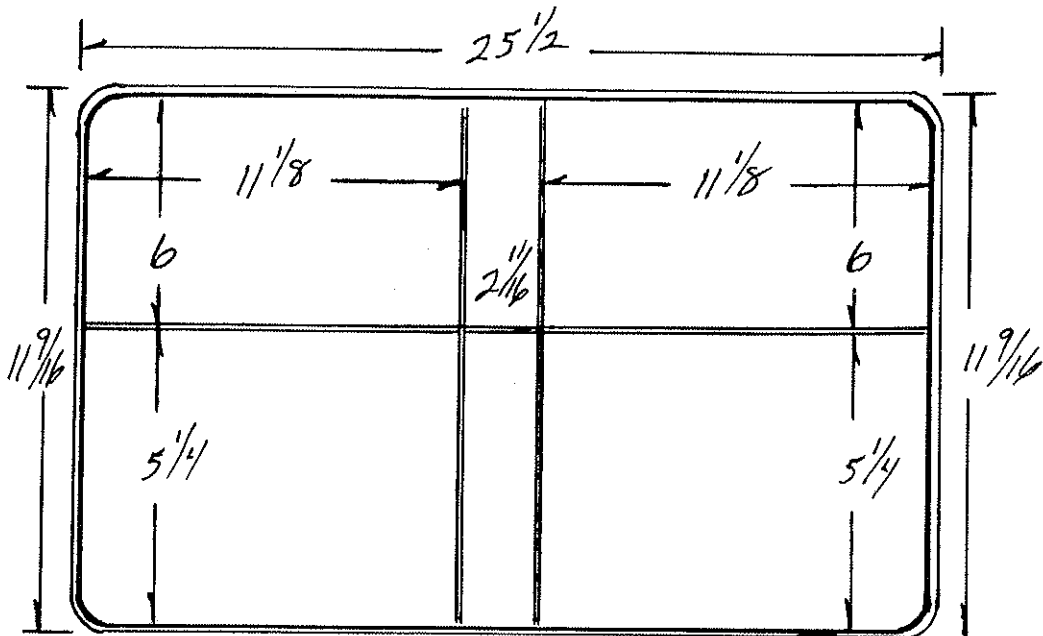

	Gauge	Thick
Tear Seal	<u>016</u>	<u>3/32</u>
Bar Seal	<u>178</u>	<u>3/16</u>
Bar Seal		

	No. of Feet
Tear Seal	
Bar Seal	
Bar Seal	

Code	Ga.	PCS	Cutting Specs		Code	K.P.D.	Ga.	Pcs.	Cutting Specs	
			Size	Out					Size	Out
Cover Mat.			<u>12 3/16 X</u>	<u>26 1/4</u>						
Cover Mat.		<u>1</u>			Lining Mat.			<u>1</u>		
Cover Mat.			X		Lining Mat.			X		
Vert. Pckt. Strap			<u>9 X</u>	<u>2 1/2</u>	Horz. Pckt.			X		
Vert. Pckt.			X		Horz. Pckt.			X		
Pocket			X		Pocket			X		
Label Holder			X		Card Holder			X		
Material			X		Material			X		
Material			X		Material			X		
Material			X		Material			X		
F.C. Board			<u>5 29/32 X</u>	<u>11 1/32</u>	B.B. Board			<u>5 29/32 X</u>	<u>2 19/32</u>	<u>100</u>
B.G. Board			<u>5 5/32 X</u>	<u>11 1/32</u>	B.B. Board			<u>5 5/32 X</u>	<u>2 19/32</u>	<u>100</u>
Center Board			<u>FC 5 7/8 X</u>	<u>11</u>	Board			<u>BB 5 7/8 X</u>	<u>2 9/16</u>	<u>100</u>
Board			<u>BC 5 7/8 X</u>	<u>11</u>	Strip			<u>BB 5 7/8 X</u>	<u>2 9/16</u>	<u>100</u>
Cover Pad			X		Strip			X		
					B.B. Pad			X		
Board			<u>5 7/8 X</u>	<u>10 5/16</u>	Spine			<u>5 7/8 X</u>	<u>2 9/16</u>	<u>1</u>
Board			<u>5 7/8 X</u>	<u>10 5/16</u>	Spine			<u>5 7/8 X</u>	<u>2 9/16</u>	<u>1</u>

Product Code

Style Case SPLIT Back Ea

Sheet Size 9 X 7 Cap. 2 Die No. 4052 Order No. 959562 Plate

Customer ZBR Publications

Metal
Total Vinyl
Quantity
Date
Type Corners <u>rd</u>
Radius <u>1/4</u>
Completed

	Gauge	Thick
Tear Seal	<u>16</u>	<u>202</u>
Bar Seal	<u>1/2</u>	<u>253</u>
Bar Seal	<u>1/2</u>	<u>72</u>

	No. of Feet
Tear Seal	
Bar Seal	
Bar Seal	

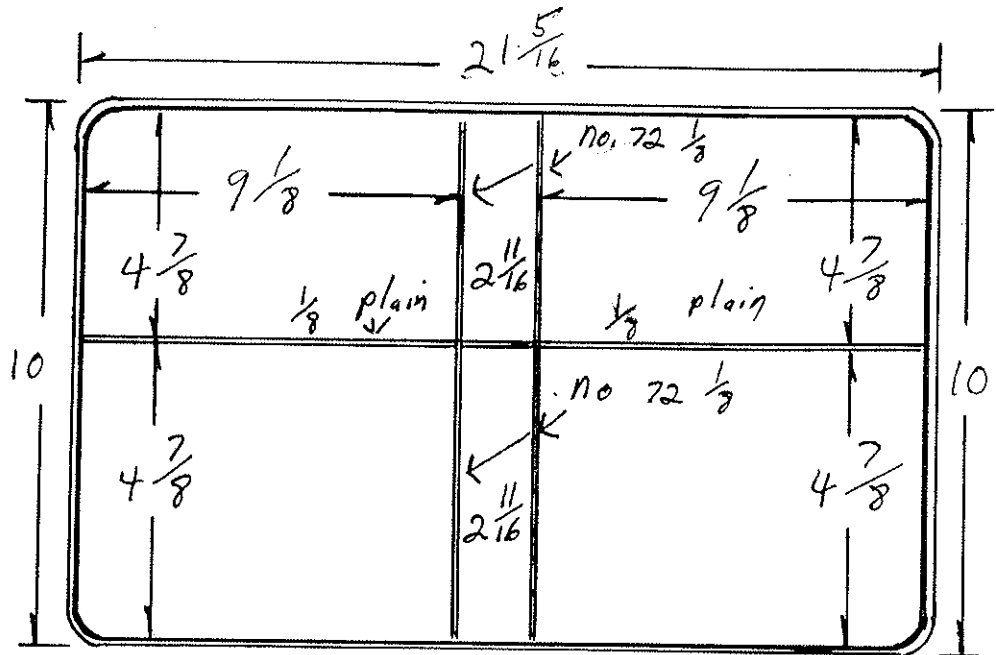

Code	Ga.	Pcs	Cutting Specs		Code	Ga.	Pcs	Cutting Specs	
			Size	Out				Size	Out
Cover Mat.			<u>10 5/8</u>	<u>22 1/16</u>	Lining Mat.			<u>10 5/8</u>	<u>22 1/16</u>
Cover Mat			X		Lining Mat.			X	
Vert. Pckt.			X		Horz. Pckt.			<u>4 7/8</u>	<u>9 3/4</u>
Vert. Pckt.			X		Horz. Pckt.			X	
Pocket			X		Pocket			X	
Label Holder			<u>4 3/4</u>	<u>2 5/16</u>	Card Holder			X	
Material			X		Material			X	
Material			X		Material			X	
Material			X		Material			X	
F.C. Board			<u>4 35/32</u>	<u>9 1/32</u>	B.C. Board			<u>4 35/32</u>	<u>9 1/32</u>
B.G. Board	<u>FG</u>		<u>4 3/4</u>	<u>9</u>	B.B. Board			<u>2 17/32</u>	<u>4 25/32</u>
Center Board	<u>BC</u>		<u>4 3/4</u>	<u>9</u>	Board	<u>BB</u>		<u>4 3/4</u>	<u>2 9/16</u>
Board			X		Strip			X	
Cover Pad			X		Strip			X	
					B.B. Pad			X	
Strap			<u>2</u>	<u>7 1/2</u>					
strap			<u>2</u>	<u>1 3/8</u>					

Product Code *Same As Sample*

Style Case *EASE!*

Sheet Size *9 x 7 1/2* Cap. *1 1/2* Die No. *4055*

Order No. *959724* Plate

Customer *Digital Equipment Corp*

Metal
Total Vinyl
Quantity
Date
Type Corners <i>Ad</i>
Radius <i>1/4</i>
Completed

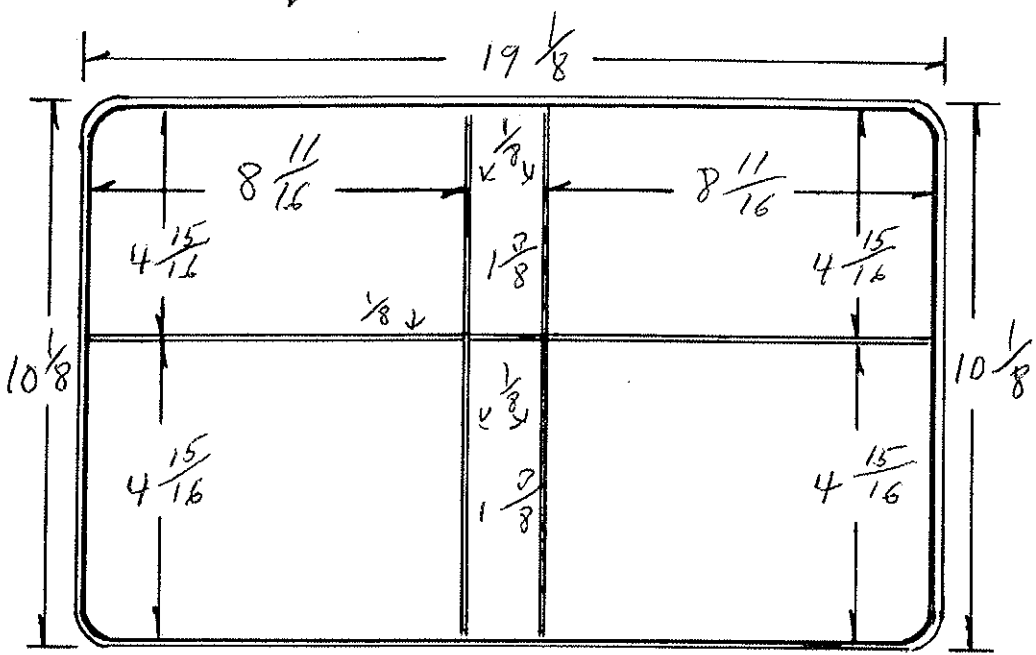

	Gauge	Thick
Tear Seal	<i>16</i>	<i>1/2</i>
Bar Seal	<i>253</i>	<i>1/8</i>
Bar Seal		

	No. of Feet
Tear Seal	
Bar Seal	
Bar Seal	

Code	Ga.	#	Cutting Specs		Code	Ga.	#	Cutting Specs	
			Size	Out				Size	Out
Cover Mat.			<i>10 3/4</i>	<i>19 7/8</i>	Lining Mat.			<i>10 3/4</i>	<i>19 7/8</i>
Cover Mat.			X		Lining Mat.			X	
Vert. Pckt.			X		Horz. Pckt.			<i>4 7/8</i>	<i>10 5/8</i>
Vert. Pckt.			X		Horz. Pckt.			X	
Pocket			X		Pocket			X	
Label Holder			X		Card Holder			X	
Material			X		Material			X	
Material			X		Material			X	
Material			X		Material			X	
F.C. Board			<i>4 27/32</i>	<i>8 19/32</i>	B.C. Board			<i>4 27/32</i>	<i>8 19/32</i>
B.C. Board	<i>FC</i>		<i>4 13/16</i>	<i>8 9/16</i>	B.B. Board			<i>4 27/32</i>	<i>1 3/32</i>
Center Board	<i>BC</i>		<i>4 13/16</i>	<i>8 9/16</i>	Board	<i>BB</i>		<i>4 13/16</i>	<i>1 1/4</i>
Board			X		Strip			X	
Cover Pad			X		Strip			X	
					B.B. Pad			X	

Product Code

Style Case *SPLIT BACK CASE*

Sheet Size $8\frac{1}{2}$ x $6\frac{1}{2}$ Cap. $1\frac{1}{2}$ Die No. 4106

Order No. 961091 Plate

Customer *DIGITAL EQUIPMENT CORP.*

Metal
Total Vinyl
Quantity 7 ?
Date 12-12-88
Type Corners <i>ACTUAL 3/8 SIZE</i>
Radius $\frac{3}{8}$
Completed

Gauge	Thick
Tear Seal 316	$\frac{3}{32}$
Bar Seal 1/8	253
Bar Seal	

No. of Feet	
Tear Seal	
Bar Seal	
Bar Seal	

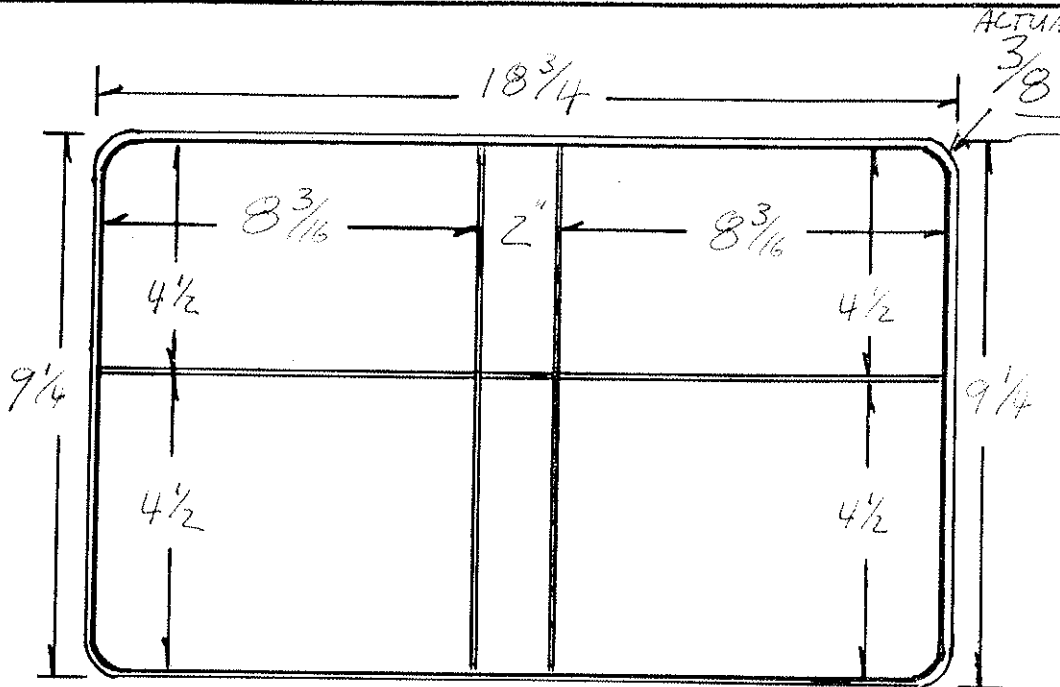

* ALL BARS = $\frac{1}{8}$ " PLAIN

Code		Ga.	# PCS	Size	Out	Code		Ga.	# Pcs.	Size	Out
Cover Mat.	$19\frac{1}{2}$ X 10	15	1			Lining Mat.	$19\frac{1}{2}$ X 10	15	1		
Cover Mat.	X					Lining Mat.	X				
Vert. Pckt.	X					Horz. Pckt.	$8\frac{3}{4}$ X $4\frac{5}{16}$	15	1		
Vert. Rckt.	X					Horz. Pckt.	X				
Pocket	X					Pocket	X				
Label Holder	$4\frac{3}{8}$ X 3	10	1			Card Holder	X				
Material	X <i>NOTE:</i>					Material	<i>** NOTE!</i>				
Material	X <i>GRAIN</i>					Material	X <i>GRAIN</i>				
Material	X <i>DIRECTION</i>					Material	X <i>DIRECTION</i>				
F.C. Board	$4\frac{13}{32}$ X $8\frac{3}{32}$	100	2			B.C. Board	X				
B.G. Board	$4\frac{13}{32}$ X $8\frac{3}{32}$	100	2			B.B. Board	$1\frac{29}{32}$ X $4\frac{13}{32}$	100	2		
Center Board	<i>FC</i> $4\frac{3}{8}$ X $8\frac{1}{16}$	100	2			Board	<i>BB</i> $4\frac{3}{8}$ X $1\frac{7}{8}$	100	2		
Board	<i>BC</i> $4\frac{3}{8}$ X $8\frac{1}{16}$	100	2			Strip	X				
Cover Pad	X					Strip	X				
						B.B. Pad	X				
<i>CASEY:</i>											
<i>NOTE * WE WILL USE UNITIZED BOARD FOR ORDER</i>											

Product Code

Style Case

S.B. CASE.

Sheet Size 9 X 7

Cap. 2

Die No. 4108

Order No. 961092

Plate

Customer DIGITAL

Metal
Total Vinyl
Quantity
Date 12-12-88 B.P.
Type Corners RND
Radius 70
Completed

	Gauge	Thick
Tear Seal	16	3/32
Bar Seal	16	1/2
Bar Seal		

	No. of Feet
Tear Seal	
Bar Seal	
Bar Seal	

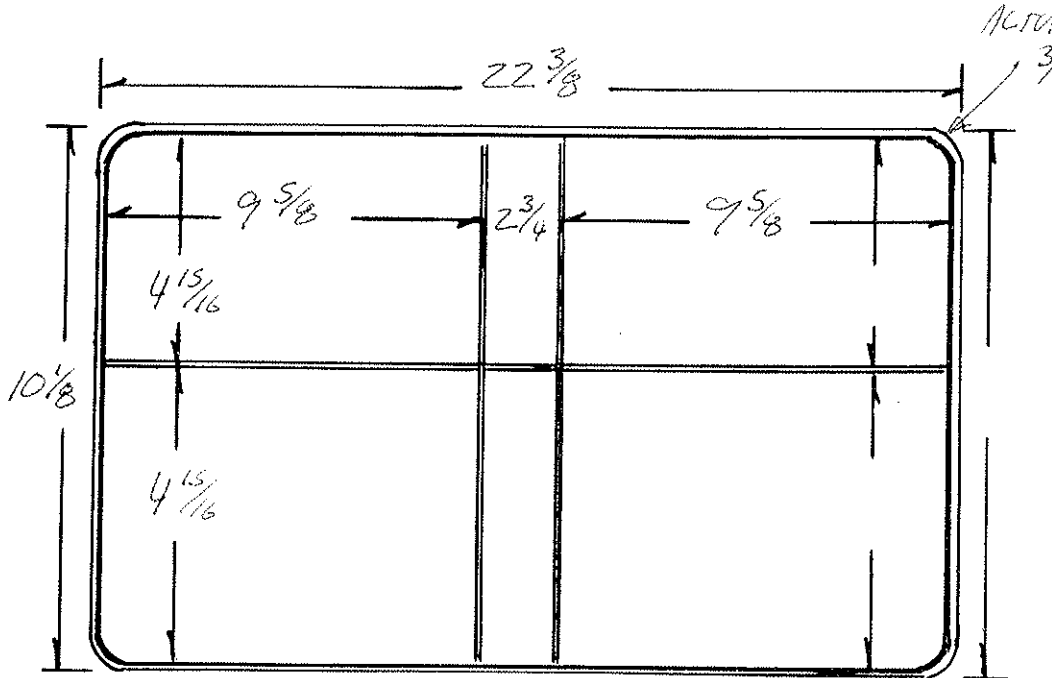

Code	Ga.	PCS	Cutting Specs		Code	Ga.	Pcs.	Cutting Specs.	
			Size	Out				Size	Out
Cover Mat.		23 1/8 X 11	15	1	Lining Mat.		23 1/8 X 11	15	1
Cover Mat.		X			Lining Mat.		X		
Vert. Pckt.		X			Horz. Pckt.		4 7/8 X 10 1/8	15	1
Vert. Pckt.		X			Horz. Pckt.		X		
Pocket		X			Pocket		X		
Label Holder		4 13/16 X 2 1/8	10	1	Card Hlder		X		
Material		X GRAW			Material		X		
Material		X Direction			Material		X GRAW		
Material		X V			Material		X Direction		
F.C. Board		4 27/32 X 9 17/32	100	2	B.C. Board		X V		
B.C. Board		4 27/32 X 9 17/32	100	2	B.B. Board		2 21/32 X 4 27/32	100	2
Center Board	FC	4 13/16 X 9 1/2	120	2	Board	BB	4 13/16 X 2 5/8	120	2
Board	BC	4 13/16 X 9 1/2	120	2	Strip		X		
Cover Pad		X			Strip		Panel Bd. Die for FC & BB		
					B.B. Pad		11 1/4 X 13 11/16		
* ORDER WILL BE CANCELLED (2020)									

Product Code

Style Case

VRB SPLIT-BACK EASEL

Sheet Size 9 1/2 x 7 1/2 Cap. 1"

Die No. 4126

Order No.

Plate

Customer DIGITAL

Metal
Total Vinyl
Quantity
Date
Type Corners
Radius
Completed

	Gauge	Thick
Tear Seal		2 RT.
Bar Seal		
Bar Seal		

	No. of Feet
Tear Seal	
Bar Seal	
Bar Seal	

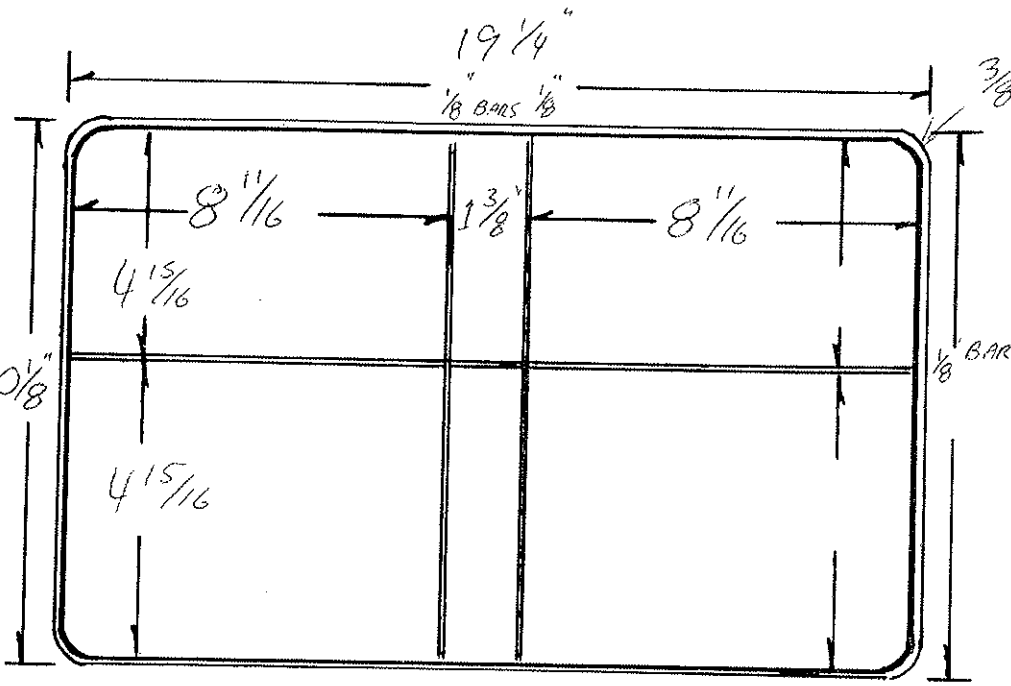

USE STRAP DIE # 4127

Code		Cutting Specs		Code		Cutting Specs			
		Ga.	PCS	Size	Out	Ga.	PCS	Size	Out
Cover Mat.	11 x 20	15	1			Lining Mat.	11 x 20	15	1
Cover Mat	X					Lining Mat.	X		
Vert. Pckt.	X					Horz. Pckt.	X		
Vert. Pckt.	X					Horz. Pckt.	5 x 11 1/4	8	1
Pocket	X					Pocket	X		
Label Holder	X					Card Holder	X		
Material	X					Material	X		
Material	X					Material	X		
Material	X					Material	X		
F.C. Board	4 27/32 x 8 19/32	100	2			B.C. Board	X		
B.C. Board	4 27/32 x 8 19/32	100	2			B.B. Board	4 27/32 x 1 9/32	100	2
Center Board	FC 4 13/16 x 8 9/16	120	2			Board	B.B. 4 13/16 x 1 1/4	120	2
Board	BC 4 13/16 x 8 9/16	120	2			Strip	X		
Cover Pad	X					Strip	X		
						B.B. Pad	X		

Product Code

Style Case *S.B. CASE*

Sheet Size *9 x 7*

Cap. *1/2*

Die No. *4107*

Order No. *961090.1*

Plate

Customer *DIGITAL*

Metal
Total Vinyl
Quantity
Date <i>17-12-88</i>
Type Corners <i>RND</i>
Radius <i>3/8</i>
Completed

	Gauge	Thick
Tear Seal	<i>16</i>	<i>3/32</i>
Bar Seal	<i>16</i>	<i>1/8</i>
Bar Seal		

	No. of Feet
Tear Seal	
Bar Seal	
Bar Seal	

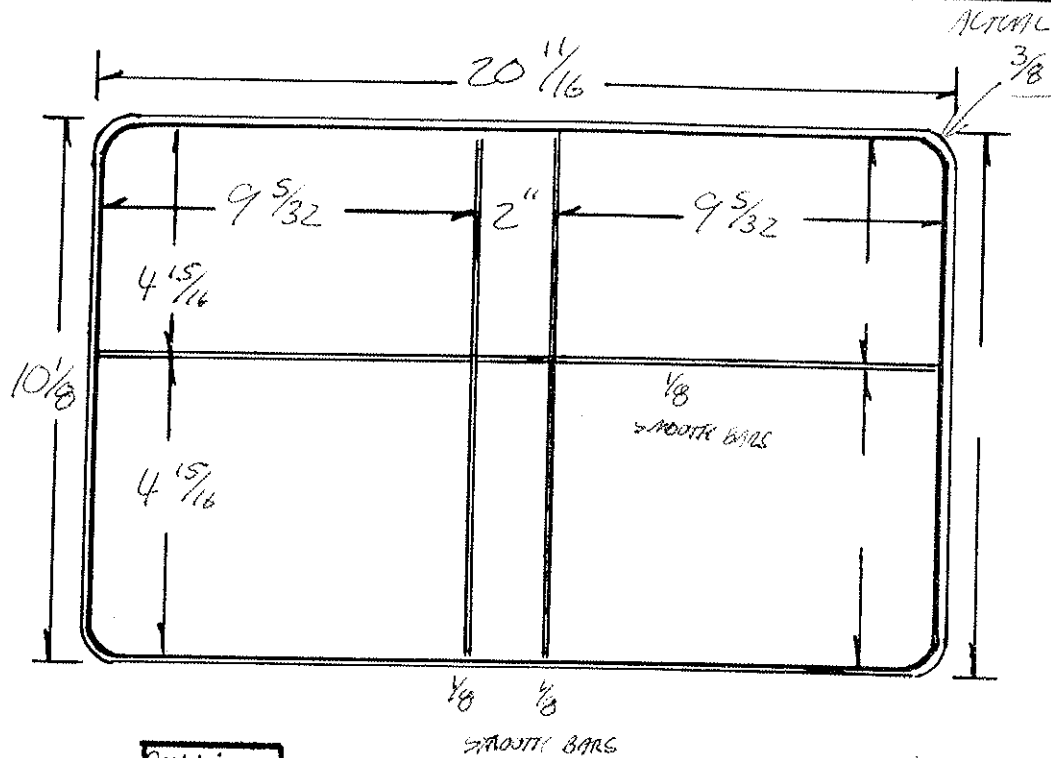

Code		Cutting Specs		Code		Cutting Specs			
		Ga.	# PCS	Size	Out	Ga.	# Pcs.	Size	Out
Cover Mat.	<i>2 1/2 x 11</i>	<i>15</i>	<i>1</i>			Lining Mat.	<i>2 1/2 x 11</i>	<i>15</i>	<i>1</i>
Cover Mat.	X					Lining Mat.	X		
Vert. Pckt.	X					Horz. Pckt.	<i>4 7/8 x 9 1/16</i>	<i>15</i>	<i>1</i>
Vert. Pckt.	X					Horz. Pckt.	X		
Pocket	X					Pocket	X		
Label Holder	<i>4 13/16 x 3</i>	<i>10</i>	<i>1</i>			Card Holder	X		
Material	X <i>GRAIN</i>					Material	X		
Material	X <i>DIRECTION</i>					Material	X <i>GRAIN</i>		
Material	X <i>↓</i>					Material	X <i>DIRECTION</i>		
F.C. Board	<i>4 27/32 x 9 1/16</i>	<i>100</i>	<i>2</i>			B.C. Board	X <i>1/16</i>		
B.C. Board	<i>4 27/32 x 9 1/16</i>	<i>100</i>	<i>2</i>			B.B. Board	<i>1 29/32 x 4 27/32</i>	<i>100</i>	<i>2</i>
Center Board	<i>FC 4 13/16 x 9 1/32</i>	<i>120</i>	<i>2</i>			Board	<i>BB 4 13/16 x 1 7/8</i>	<i>120</i>	<i>2</i>
Board	<i>BC 4 13/16 x 9 1/32</i>	<i>120</i>	<i>2</i>			Strip	X		
Cover Pad	X					Strip	X		
						B.B. Pad	X		

Product Code

OLD DIE 1294

Style Case *SPLITBACK VRS EASLE*

Sheet Size $8\frac{1}{2} \times 6$

Cap. $1\frac{1}{2}$

Die No. 4183

Order No. 59014.1

Plate

Customer *EBSCO MEDIA*

Metal
Total Vinyl
Quantity
Date <i>4-13-87</i>
Type Corners <i>RND.</i>
Radius $\frac{3}{8}$ "
Completed

	Gauge	Thick
Tear Seal	$.016$ "	$\frac{3}{32}$
Bar Seal		$\frac{1}{8}$
Bar Seal		

	No. of Feet
Tear Seal	
Bar Seal	
Bar Seal	

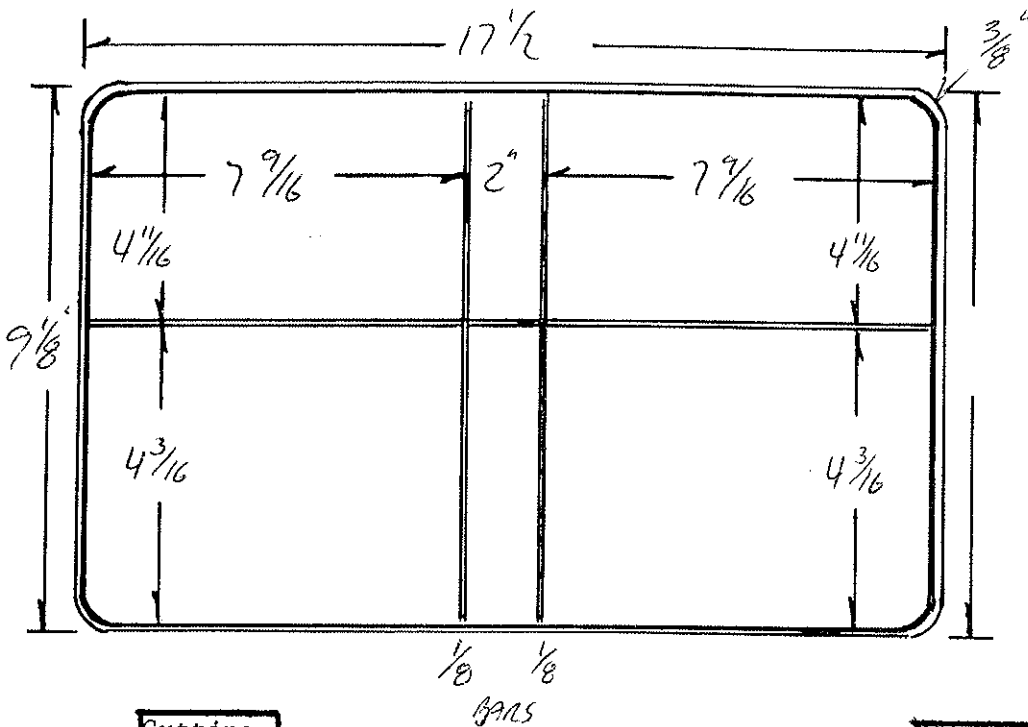

Code		Ga.	# PCS	Size	Cutting Specs	Code		Ga.	# Pcs.	Size	Cutting Specs
Cover Mat.		$9\frac{7}{8}$ "	15	$18\frac{1}{4}$		Lining Mat.		$9\frac{7}{8}$ "	15	$18\frac{1}{4}$	
Cover Mat		X				Lining Mat.		X			
Vert. Pckt.	<i>Strap</i>			$9 \times 2\frac{1}{2}$		Horz. Pckt.					
Vert. Pckt.		X				Horz. Pckt.		X			
Pocket		X				Pocket		X			
Label Holder		X				Card Holder		X			
Material		X				Material		X			
Material		X				Material		X			
Material		X				Material		X			
<i>UPPER</i> B.B. Board	<i>UPPER</i>	$4\frac{19}{32}$	100	$7\frac{15}{32}$		<i>B.B.</i> Board	<i>UPPER</i>	$4\frac{19}{32}$	100	$7\frac{29}{32}$	
<i>LOWER</i> B.B. Board	<i>LOWER</i>	$4\frac{3}{32}$	100	$7\frac{15}{32}$		B.B. Board	<i>LOWER</i>	$4\frac{3}{32}$	100	$7\frac{29}{32}$	
Center Board	<i>UPPER</i>	$4\frac{9}{16}$	120	$7\frac{7}{16}$		Board	<i>UPPER</i>	$4\frac{9}{16}$	120	$7\frac{7}{8}$	
Board	<i>LOWER</i>	$4\frac{1}{16}$	120	$7\frac{7}{16}$		Strip	<i>LOWER</i>	$4\frac{1}{16}$	120	$7\frac{7}{8}$	
Cover Pad		X				Strip		X			
						B.B. Pad		X			

OLD DIE # 1132

Product Code

Style Case SPLITBACK easle VRS

Sheet Size 8 1/2 x 6

Cap. 2

Die No. 4247

Order No. 963051.1

Plate

Customer UNITED TELEPHONE CO.

Metal
Total Vinyl
Quantity
Date <u>7-19-89</u>
Type Corners <u>AND</u>
Radius <u>3/8"</u>
Completed

	Gauge	Thick
Tear Seal	<u>016</u>	<u>3/32</u>
Bar Seal	<u>#253</u>	<u>1/8</u>
Bar Seal		

	No. of Feet
Tear Seal	
Bar Seal	
Bar Seal	

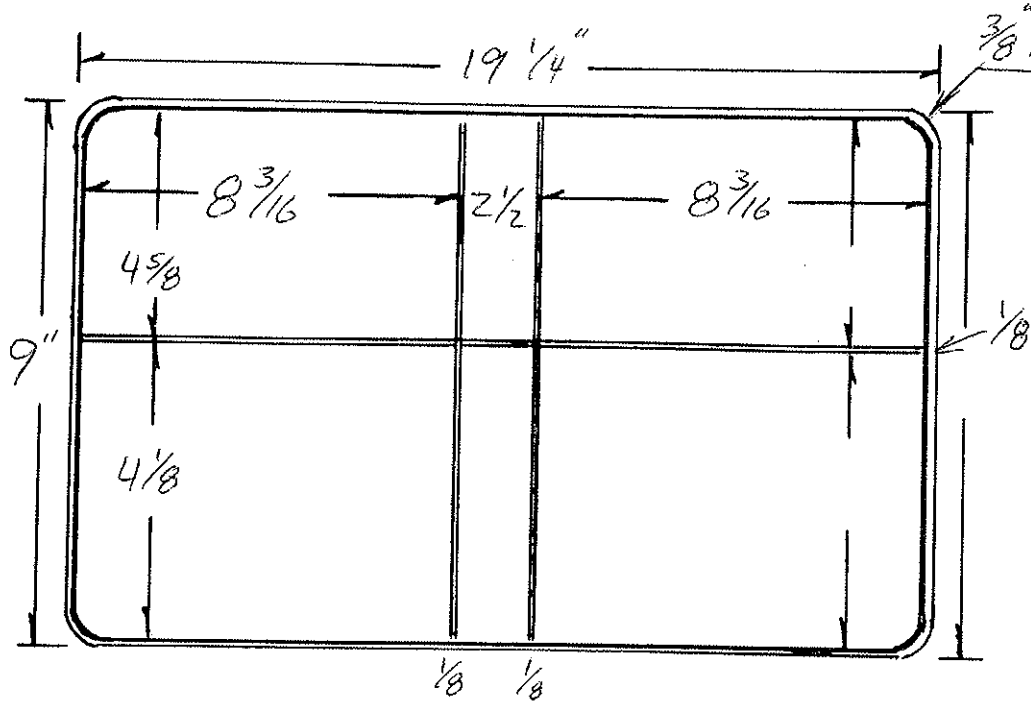

Code	Ga.	# PCS	Cutting Specs		Code	Ga.	# Pcs.	Cutting Specs			
			Size	Out				Size	Out		
Cover Mat.			9 3/4	X 20	15	1	Lining Mat.		9 3/4 X 20	15	1
Cover Mat.				X			Lining Mat.		X		
Vert. Pckt.				X			Horz. Pckt.		X		
Vert. Pckt.				X			Horz. Pckt.		X		
Pocket				X			Pocket		X		
Label Holder				X			Card Holder		X		
Material				X			Material		X		
Material				X			Material	STRAP	9' X 2 1/2	15	2
Material				X			Material		X		
UPPER Board			4 17/32	X 8 3/32	106	2	B.B. Board	UPPER	4 17/32 X 2 13/32	106	1
Lower Board			4 1/32	X 8 3/32	100	2	B.B. Board	LOWER	4 1/32 X 2 13/32	100	1
Center Board	upper		4 1/2	X 8 1/16	120	2	Board	upper	4 1/2 X 2 3/8	120	1
Board	lower		4	X 8 1/16	120	2	Strip	lower	4 X 2 3/8	120	1
Cover Pad				X			Strip		X		
							B.B. Pad		X		

Product Code

Style Case

SPLITBACK CASE VI

Sheet Size

11 x 9

Cap. 1/2

Die No. 4251

Order No. 963097

Plate

Customer

AAFC5

Metal
Total Vinyl
Quantity 400
Date 7-25-89
Type Corners RND
Radius 3/8"
Completed

	Gauge	Thick
Tear Seal		
Bar Seal	2PT	
Bar Seal		

	No. of Feet
Tear Seal	
Bar Seal	
Bar Seal	

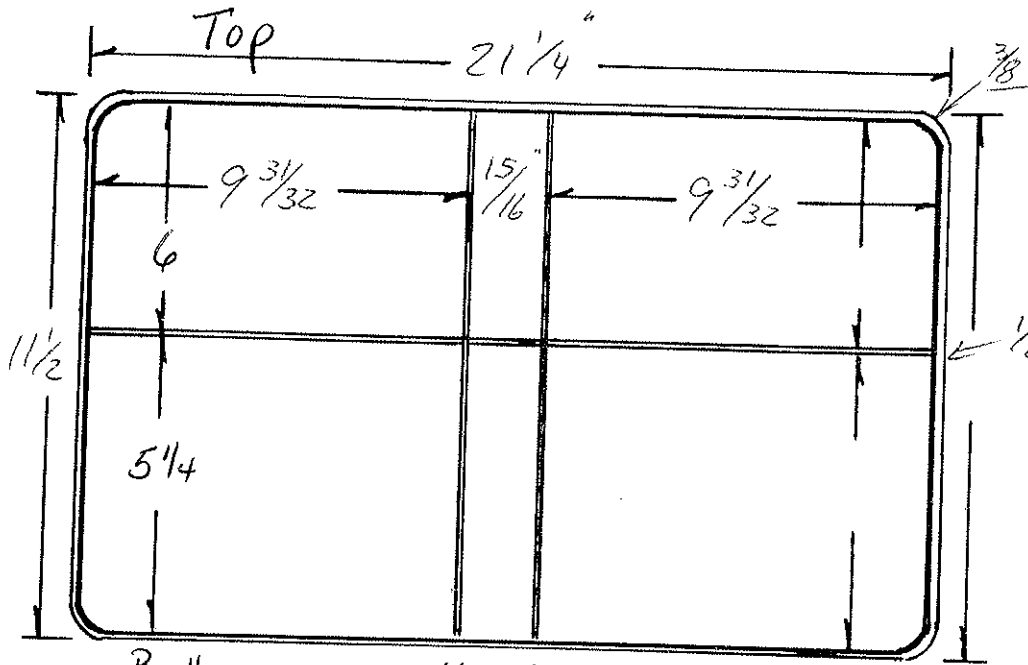

POLY STRAP

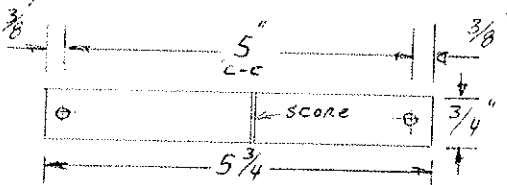

Bottom

1/8 1/8 BARS

		Cutting Specs						Cutting Specs			
Code		Ga.	# PCS	Size	Out	Code		Ga.	# Pcs.	Size	Out
Cover Mat.				12 1/4 X 22							
Cover Mat.				X		Lining Mat.				12 1/4 X 22	
Vert. Pckt.				X		Lining Mat.				X	
Vert. Pckt.				X		Horz. Pckt.				X	
Pocket				X		Horz. Pckt.				X	
Label Holder				X		Pocket				X	
Material				X		Card Holder				X	
Material				X		Material	POLY			X	
Material				X		Material	STRAP	5 3/4 X 3/4"	35	1	
Board	UPPER			5 5/32 X 9 7/8"	100	2	Material			X	
Board	LOWER			5 29/32 X 9 7/8"	100	2	B.B. Board	UPPER	5 5/32 X 27/32	100	1
Center Board	upper			5 1/8 X 9 27/32	120	2	B.B. Board	LOWER	5 29/32 X 27/32	100	1
Board	lower			5 7/8 X 9 27/32	120	2	Board	upper	5 1/8 X 13/16	120	1
Cover Pad				X			Strip	lower	5 7/8 X 13/16	120	1
							Strip			X	
							B.B. Pad			X	

NATURAL EDGE

Product Code

Style Case **SPLIT BACK EASLE**

Sheet Size **11 x 9**

Cap. **2**

Die No. **4290**

Order No. **40866**

Plate

Customer	NORTHERN TELECOM	
Metal		
Total Vinyl		
Quantity		
Date	9-27-69	
Type Corners		
Radius	3/8"	
Completed	9-29-69	RET

	Gauge	Thick
Tear Seal	.014 R	1/16
Bar Seal		
Bar Seal		

	No. of Feet
Tear Seal	
Bar Seal	
Bar Seal	

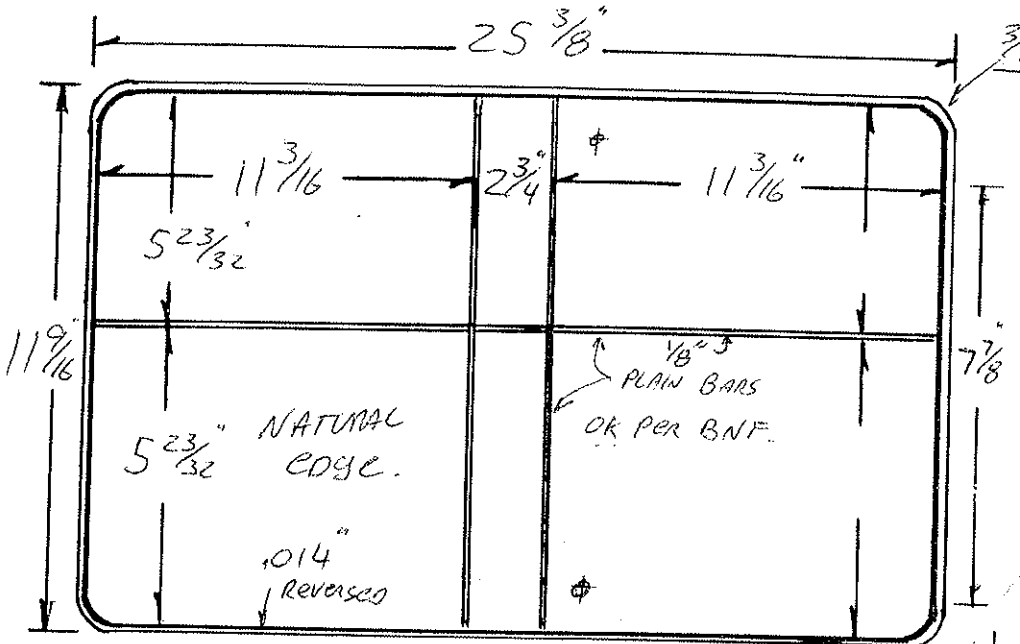

NATURAL edge

SIZE BY: B.P.

CHECK BY: DM

See 4240 B FOR NEW STRAP Code

Code		Ga.	# PCS	Size	Out	Cutting Specs.	Code		Ga.	# Pcs.	Size	Out	Cutting Specs.
Cover Mat.	12 1/4 x 26 1/8	15	1				Lining Mat.	12 1/4 x 26 1/8	15	1			
Cover Mat	X						Lining Mat.	X					
Vert. Pckt.	X						Horz. Pckt.	X					
Vert. Pckt.	X						Horz. Pckt.	X					
Pocket	X						Pocket	X					
Label Holder	X						Card Holder	Strap Die # 4290B					
Material	X						Material	STRAP 7 3/4 x 2 3/4	15	2			
Material	X						Material	BOOSTER POCKET 1 3/8" x 2 3/4	15	1			
Material	X						Material	X					
F.C. Board	5 5/8 x 11 3/32	100	2				B.C. Board	X					
B.C. Board	5 5/8 x 11 3/32	100	2				B.B. Board	5 5/8 x 2 21/32	100	2			
Center Board	FC 5 19/32 x 11 1/16	120	2				Board	BB 5 19/32 x 2 21/32	120	2			
Board	BC 5 19/32 x 11 1/16	120	2				Strip	X					
Cover Pad	X						Strip	X					
							B.B. Pad	X					

DIE # 4326		STYLE CASE VINYL SPLIT BACK EASEAL		LOCATION	
SHEET SIZE 11 X 9			CAP. 1 1/2	ORDER #	
CUSTOMER		STOCK		DUE DATE	
QUANTITY		RADIUS		TEAR SEAL	
DATE		COMPLETED		BAR SEAL	

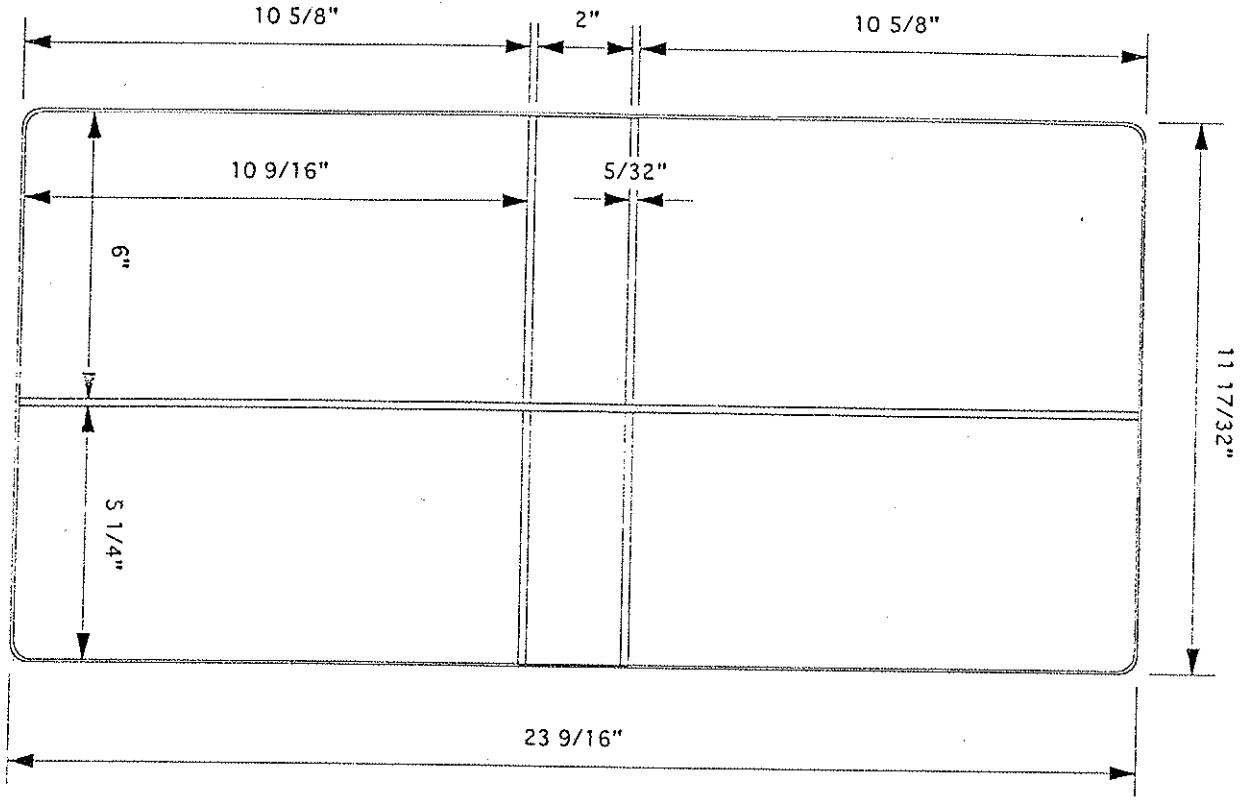

MATERIAL SPECS

GA PCS

GA PCS

COVER MATL	12 1/4 X 24 3/8	1	LINING	12 1/4 X 24 3/8	1
COVER MATL			LINING		
VERT PKT			HORZ PKT	5 3/8 X 11 1 SIDE	1
VERT PKT			HORZPKT	5 3/8 X 24 3/8 FULL	1
CARD HOLDER			DIAGONAL PKT		
COL			LABEL HOLDER		
EX COL			GUSSETT		
FC-BB-BC	Padded Bd. 4326-A		REINF		
	1.5 x 22 1/2		STRAP	9 X 2 1/2	2

BOARD SPECS

F.C. UPPER	5 X 10	100	1	F.C. LOWER	5 3/16 X 10 1/2	100	1
B.B. UPPER	5 X 1 29/32	100	1	B.B. LOWER	5 3/16 X 1 29/32	100	1
B.C. UPPER	5 X 10	100	1	B.C. LOWER	5 3/16 X 10 1/2	100	1
FC UPPER	5 29/32 X 10 15/32	120	1	FC LOWER	5 5/32 X 10 15/32	120	1
BB UPPER	5 29/32 X 1 29/32	120	1	BB LOWER	5 5/32 X 1 29/32	120	1
BC UPPER	5 29/32 X 10 15/32	120	1	B C LOWER	5 5/32 X 10 15/32	120	1

Product Code

Style Case *SPLITBACK EASEL VRB*

Sheet Size *8 1/2 X 6*

Cap. *1/2*

Die No. *4423-A*

Order No. *965409*

Plate

Customer

ARMADILLO PHOTO SUPPLY

Metal
Total Vinyl
Quantity <i>200</i>
Date <i>5-10-90</i>
Type Corners
Radius <i>3/8</i>
Completed

	Gauge	Thick
Tear Seal	<i>.014</i>	<i>1/16"</i>
Bar Seal	<i>4253</i>	<i>1/8"</i>
Bar Seal		

	No. of Feet
Tear Seal	
Bar Seal	
Bar Seal	

Size - B.P.K.E

Check -

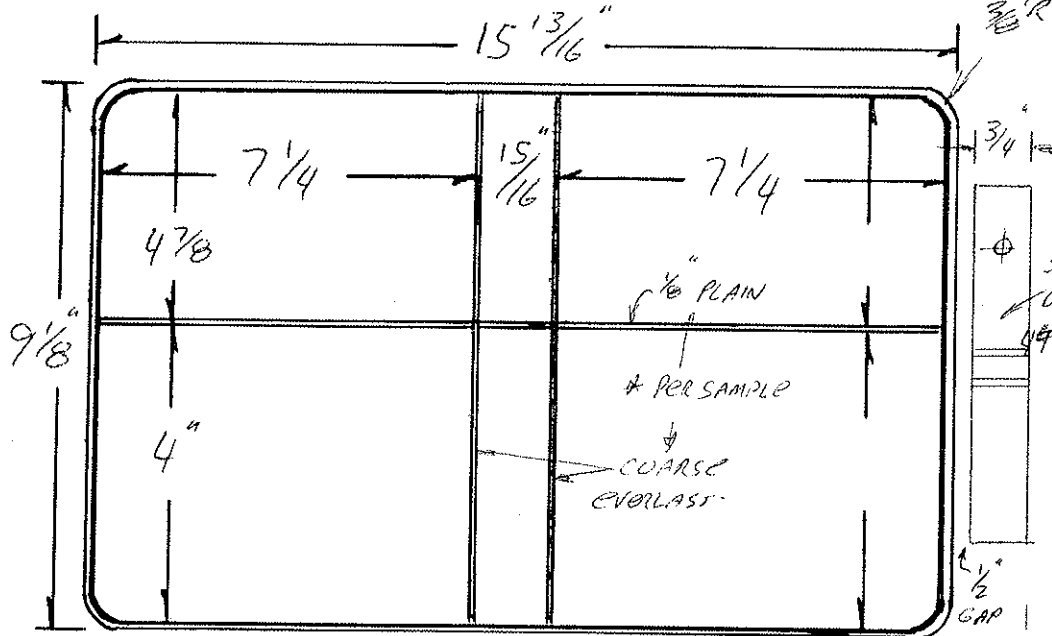

	Code	Cutting Specs				Code	Cutting Specs						
		Ga.	PCS	Size	Out		Ga.	PCS	Size	Out			
Cover Mat.				<i>9 3/4" X 18</i>				<i>9 3/4" X 18</i>					
Cover Mat.				X				X					
Vert. Pckt.				X				Horz. Pckt. <i>J.F.B.C.</i>	<i>4" X 16 1/2</i>	<i>8</i>	<i>1</i>		
Vert. Pckt.				X				Horz. Pckt. <i>O.F.C.</i>	<i>4 3/16" X 7 3/4</i>	<i>8</i>	<i>1</i>		
Pocket				X				Pocket	X				
Label Holder				X				Card Holder	X				
Material				X				Material	X				
Material				X				Material	X				
Material				X				Material	X				
UPPER Boards				<i>4 25/32" X 7 5/32</i>	<i>100</i>	<i>2</i>		UPPER B.B.	<i>4 25/32" X 27/32</i>	<i>100</i>	<i>1</i>		
LOWER Board				<i>3 29/32" X 7 5/32</i>	<i>100</i>	<i>2</i>		LOWER B.B.	<i>3 29/32" X 27/32</i>	<i>100</i>	<i>1</i>		
Center Board				X				Board	X				
Board				X				Strip	X				
Cover Pad				X				Strip	X				
								B.B. Pad	X				

Product Code _____ STRAP# 4523 Style Case SPLIT-BACK CASE
 Sheet Size 13 x 13 1/2 Cap. 1 1/2 Die No. 4522 Order No. 966498 Plate _____

Customer COLAD

Metal
Total Vinyl
Quantity <u>26,000</u>
Date <u>8-31-50</u>
Type Corners <u>Round</u>
Radius <u>3/8" R</u>
Completed

Gauge	Thick
Tear Seal <u>.014</u>	<u>1/16"</u>
Bar Seal <u>#253</u>	<u>1/16"</u>
Bar Seal	

No. of Feet	
Tear Seal	
Bar Seal	
Bar Seal	

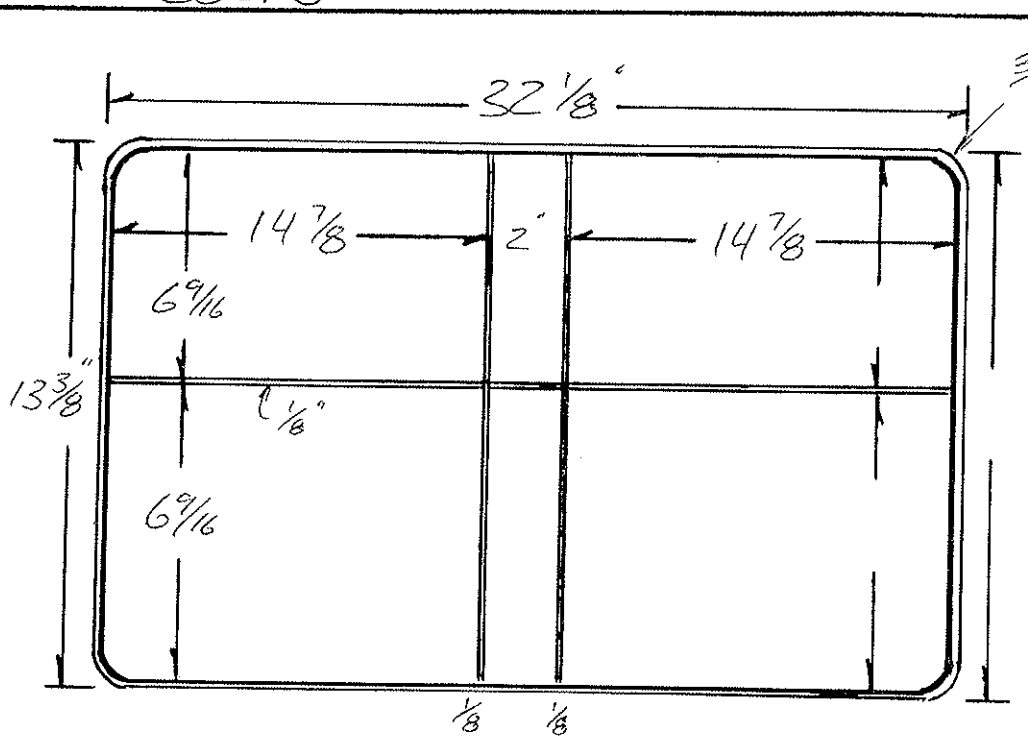

Dwg by: BP
 Spec/Check by: (Signature)

Re Spec 9/12
 KP JW Code

		Cutting Specs		Code		Cutting Specs			
		Ga.	PCS	Size	Out	Ga.	Pcs.	Size	Out
Cover Mat.	<u>14 3/8 X 33 1/8</u>		<u>1</u>			Lining Mat.		<u>14 3/8 X 33 1/8</u>	<u>1</u>
Cover Mat	X					Lining Mat.		X	
Vert. Pckt.	X <u>X</u>					Horz. Pckt.		X	
Vert. Pckt.	X					Horz. Pckt.		X	
Pocket	X					Pocket		X	
Label Holder	X					Card Holder		X	
Material	X					Material		X	
Material	X					Material		X	
Material	X					Material		X	
F.C. Board <u>Padded</u>	<u>6 7/16 X 14 3/4</u>	<u>120</u>	<u>2</u>			B.C. Board		X	
B.C. Board <u>Padded</u>	<u>6 7/16 X 14 3/4</u>	<u>120</u>	<u>2</u>			B.B. Board	<u>6 13/32 X 1 23/32</u>	<u>100</u>	<u>2</u>
Center Board	X					Board		X	
Board	X					<u>Padded Strip</u>	<u>6 7/16 X 1 7/8</u>	<u>30</u>	<u>2</u>
Cover Pad	X					Strip		X	
						B.B. Pad		X	

Product Code

Style Case *SPLIT BACK CASE VRS*

Sheet Size *8 1/2 x 6*

Cap. *2*

Die No. *4631*

Order No. *967463*

Plate

Customer

COMM. MKTG., DIST., SVCS., INC.

Metal
Total Vinyl
Quantity <i>350</i>
Date <i>1-9-91</i>
Type Corners
Radius <i>3/8</i>
Completed

	Gauge	Thick
Tear Seal	<i>.012</i>	<i>1/16</i>
Bar Seal	<i>#253</i>	<i>1/8"</i>
Bar Seal		

	No. of Feet
Tear Seal	
Bar Seal	
Bar Seal	

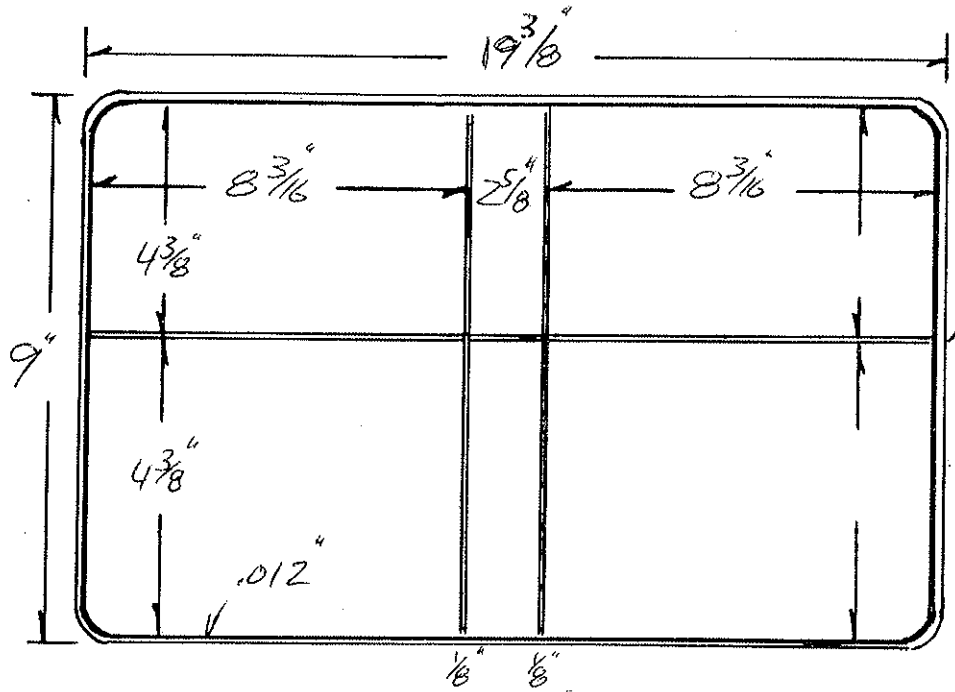

SIZE - BR
CHECK -
(Signature)

Code	Ga.	#	PCS	Cutting Specs.		Code	Ga.	#	PCS	Cutting Specs.		
				Size	Out					Size	Out	
Cover Mat.				<i>9 3/4</i>	<i>X 20</i>	Lining Mat.				<i>9 3/4</i>	<i>X 20</i>	
Cover Mat.					X	Lining Mat.					X	
Vert. Pckt.					X	Horz. Pckt.					X	
Vert. Pckt.					X	Horz. Pckt.					X	
Pocket					X	Pocket					X	
Label Holder					X	Card Holder					X	
Material					X	Material					X	
Material					X	Material					X	
Material					X	Material					X	
F.C. Board				<i>4 9/32</i>	<i>X 8 3/32</i>	B.C. Board					X	
B.C. Board				<i>4 9/32</i>	<i>X 8 3/32</i>	B.B. Board				<i>4 9/32</i>	<i>X 2 1/32</i>	<i>100 2</i>
Center Board					X	Board					X	
Board					X	Strip					X	
Cover Pad					X	Strip					X	
						B.B. Pad					X	

Product Code

Stoch Style Case SPLITBACK EISLE VRB

Sheet Size 11 x 8 1/2 Cap. Z R Die No. 4637

Order No. 967530

LOC. Plate C-10

Customer

GRAHAM KERR MARKETING

Metal
Total Vinyl
Quantity 1
Date 1-16-91
Type Corners
Radius
Completed

	Gauge	Thick
Tear Seal	.014	1/16
Bar Seal	#253	1/8"
Bar Seal		

	No. of Feet
Tear Seal	
Bar Seal	
Bar Seal	

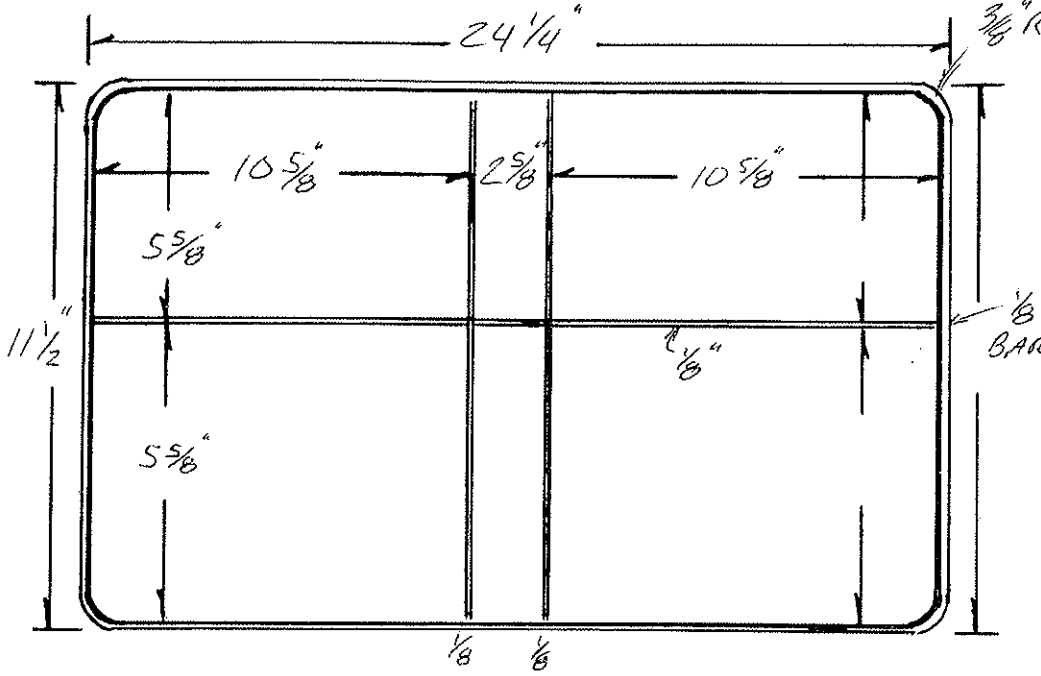

size - B.P.
 CHECK *[Signature]*

USE STRAP # 41638

Code		Cutting Specs		Code		Cutting Specs			
		Ga.	PCS	Size	Out	Ga.	Pcs.	Size	Out
Cover Mat.	12 1/4 x 25	15	1			Lining Mat.	12 1/4 x 25	15	1
Cover Mat	X					Lining Mat.	X		
Vert. Pckt.	X					Horz. Pckt. ^{UPPER 1/2} F.C.	X		
Vert. Pckt.	X					Horz. Pckt. COL.	5 3/4 x 11 1/8	8	1
Pocket	X					Pocket	X		
Label Holder	X					Card Hlder	X		
Material	X					Material	X		
Material	X					Material	X		
Material	X					Material	X		
F.C. Board	5 1/2 x 10 1/2	120	2			B.C. Board	X		
B.C. Board	5 1/2 x 10 1/2	120	2			B.B. Board	5 1/2 x 2 1/2	120	2
Center Board	X					Board	X		
Board	X					Strip	X		
Cover Pad	X					Strip	X		
						B.B. Pad	X		
FC	5 1/32 x 10 1/32		2			BB	5 1/32 x 2 1/32		2
BC	5 1/32 x 10 1/32		2						

Product Code

Style Case SPLIT-BACK CASE

Sheet Size 11 x 9 Cap. 2 1/2 Die No. 4681

Order No. 968106 Plate C-12-3

SIMPRO

Customer

Metal
Total Vinyl
Quantity <u>250</u>
Date <u>3-11-91</u>
Type Corners
Radius <u>3/8</u>
Completed

	Gauge	Thick
Tear Seal	<u>1014</u>	<u>1/16</u>
Bar Seal	<u>1783 254</u>	<u>3/16 & 5/32</u>
Bar Seal		

	No. of Feet
Tear Seal	
Bar Seal	
Bar Seal	

11 9/16

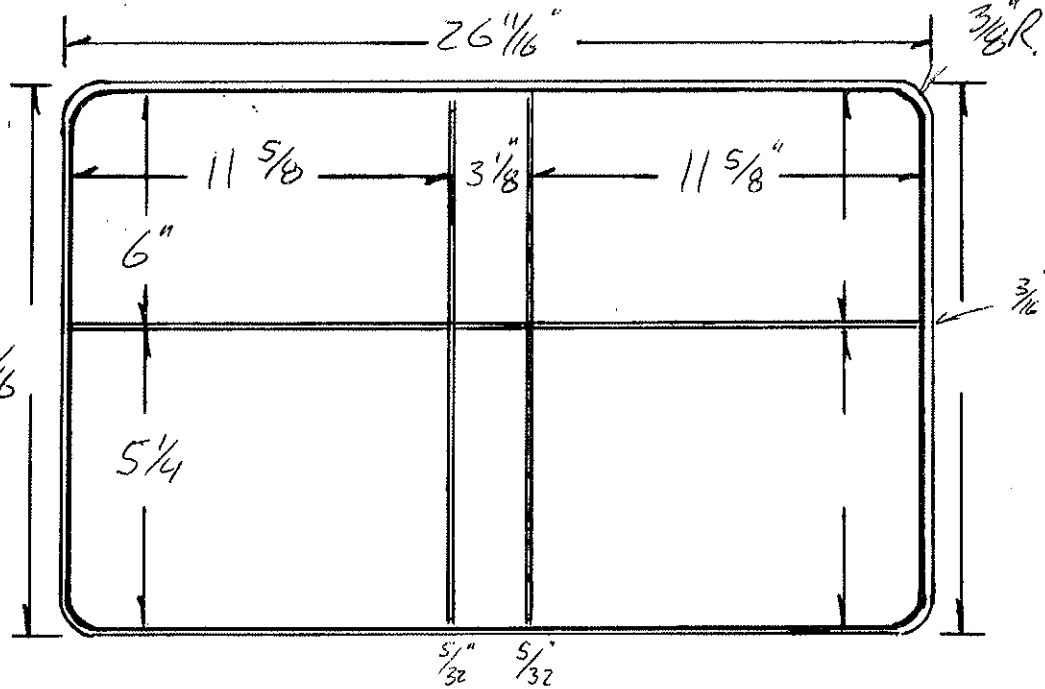

size - B. Pace
CHECK - KPV

USC STRAP DIE # 4638

Code	Ga.	# PCS	Cutting Specs		Code	Ga.	# Pcs.	Cutting Specs	
			Size	Out				Size	Out
Cover Mat.		<u>12 1/4 x 27 1/2</u>	<u>15</u>	<u>1</u>	Lining Mat.		<u>12 1/4 x 27 1/2</u>	<u>15</u>	<u>1</u>
Cover Mat.		X			Lining Mat.		X		
Vert. Pckt.		X			Horz. Pckt.		X		
Vert. Pckt.		X			Horz. Pckt.		X		
Pocket		X			Pocket		X		
Label Holder		X			Card Holder		X		
Material		X			Material		X		
Material		X			Material		X		
Material		X			Material		X		
UPPER Board		<u>5 7/8 x 11 1/2</u>	<u>120</u>	<u>2</u>	B.B. Board		<u>5 7/8 x 3"</u>	<u>120</u>	<u>1</u>
Lower Board		<u>5 7/8 x 11 1/2</u>	<u>120</u>	<u>2</u>	B.B. Board		<u>5 7/8 x 3"</u>	<u>120</u>	<u>1</u>
Center Board		X			Board		X		
Board		X			Strip		X		
Cover Pad		X			Strip		X		
					B.B. Pad		X		

Product Code

Style Case *SPLITBACK CASE C-D-I*

Sheet Size *11 x 9*

Cap. *20*

Die No. *4797A*

Order No. *9169125*

Plate *C-16*

Customer

HOLDEN LOOSLEAF

Metal
Total Vinyl
Quantity <i>1</i>
Date <i>6-6-91</i>
Type Corners
Radius <i>1/4</i>
Completed

	Gauge	Thick
Tear Seal	<i>42-016</i>	<i>1/16</i>
Bar Seal	<i>#105 HFT</i>	<i>1/8</i>
Bar Seal		

	No. of Feet
Tear Seal	
Bar Seal	
Bar Seal	

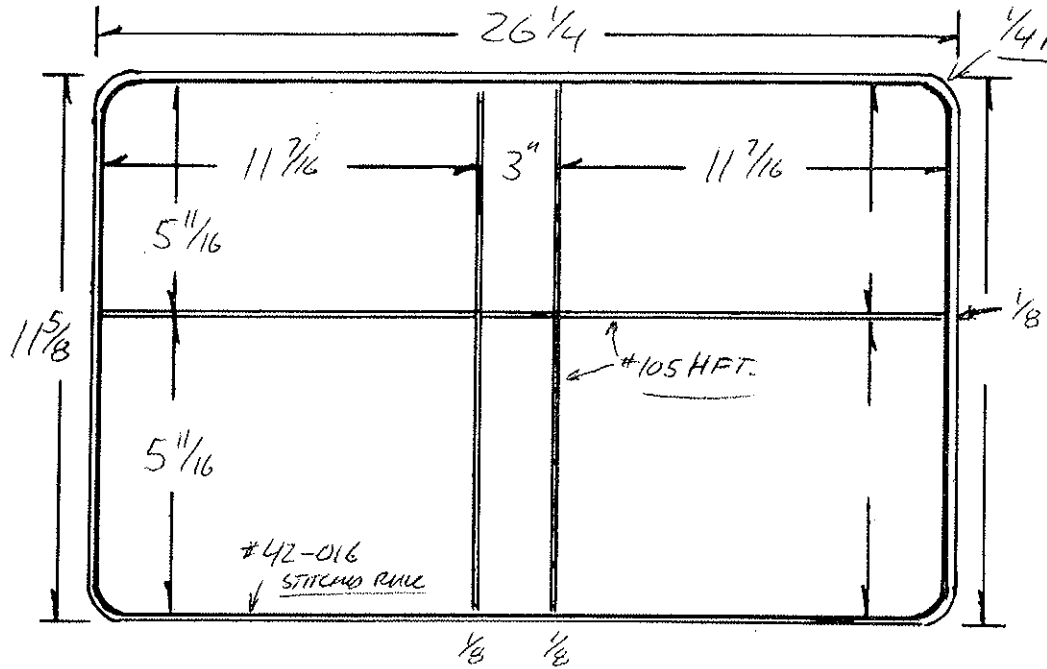

DWG - B. Price

Check [Signature]

** See STRAP 4797-B*

Code	Ga.	# PCS	Cutting Specs.		Code	Ga.	# Pcs.	Cutting Specs.	
			Size	Out				Size	Out
Cover Mat.		<i>12 1/4 X 27</i>	<i>15</i>	<i>1</i>	Lining Mat.		<i>12 1/4 X 27</i>	<i>15</i>	<i>1</i>
Cover Mat.		X			Lining Mat.		X		
Vert. Pckt.		X			Horz. Pckt. <i>JFC</i>		<i>5 3/8 X 12</i>	<i>15</i>	<i>1</i>
Vert. Pckt.		X			Horz. Pckt.		X		
Pocket		X			Pocket		X		
Label Holder		X			Card Holder <i>POLISH</i>		<i>2 7/8 X 4 3/8</i>	<i>8</i>	<i>1</i>
Material		X			Material <i>1 CORNER ROUND</i>		X		
Material		X			Material		X		
Material		X			Material		X		
F.C. Board		<i>5 19/32 X 11 1/32</i>	<i>120</i>	<i>2</i>	B.C. Board		X		
B.C. Board		<i>5 19/32 X 11 1/32</i>	<i>120</i>	<i>2</i>	B.B. Board		<i>5 19/32 X 2 29/32</i>	<i>120</i>	<i>2</i>
Center Board		X			Board		X		
Board		X			Strip		X		
Cover Pad		X			Strip		X		
					B.B. Pad		X		

Sheet Size 9 x 7

Cap. 2

Die No. 4879

Order No. 41706

Plate F.16

DIGITAL

Customer	
Metal	
Total Vinyl	
Quantity	
Date	9-17-91
Type Corners	
Radius	3/8
Completed	

See DWGS.

	Gauge	Thick
Tear Seal	.014	1/16
Bar Seal	#253	1/8"
Bar Seal		

	No. of Feet
Tear Seal	
Bar Seal	
Bar Seal	

DWG. B.Pace
 HELM

1 UP VERSION OF 4501 DIGITAL EASLE

COVER & LINING SIZE INCLUDES STRAP. (4501)

Code		Ga.	PCS	Size	Out	Cutting Specs		Code		Ga.	PCS	Size	Out	Cutting Specs	
cover Mat.	10 7/8 x 25 3/4		1			Lining Mat.	10 7/8 x 25 3/4		1						
cover Mat	X					Lining Mat.	X								
ert. Pckt.	X					Horz. Pckt.	4 3/4 x 25 3/4								
ert. Pckt.	X					Horz. Pckt.	X								
Pocket	X					Pocket	2 1/4 x 2 1/4	14	1						
Label Holder	X					Card Holder	X								
aterial	X					Material	X								
aterial	X					Material	X								
aterial	X					Material	X								
.C. Board	4 27/32 x 9 17/32		2			B.C. Board	X								
.C. Board	4 27/32 x 9 17/32		2			B.B. Board	4 37/32 x 2 21/32		2						
nterBoard	X					Board	X								
oard	X					Strip	X								
over Pad	X					Strip	X								
						B.B. Pad	X								

Product Code

Style Case *SPLIT BACK CASE VRB*

Sheet Size *11 x 9*

Cap. *Z-D* Die No. *5013B*

Order No. *971294*

Plate *D-5-*

Customer

US DATA CORP.

5-4

Metal
Total Vinyl
Quantity <i>5600</i>
Date <i>3-9-92</i>
Type Corners
Radius <i>3/8</i>
Completed

	Gauge	Thick
Tear Seal	<i>.014</i>	<i>1/16</i>
Bar Seal	<i>#253</i>	<i>1/8</i>
Bar Seal		

	No. of Feet
Tear Seal	
Bar Seal	
Bar Seal	

*+ STRAP
see
OWG.
5013-B
1/2" GAP*

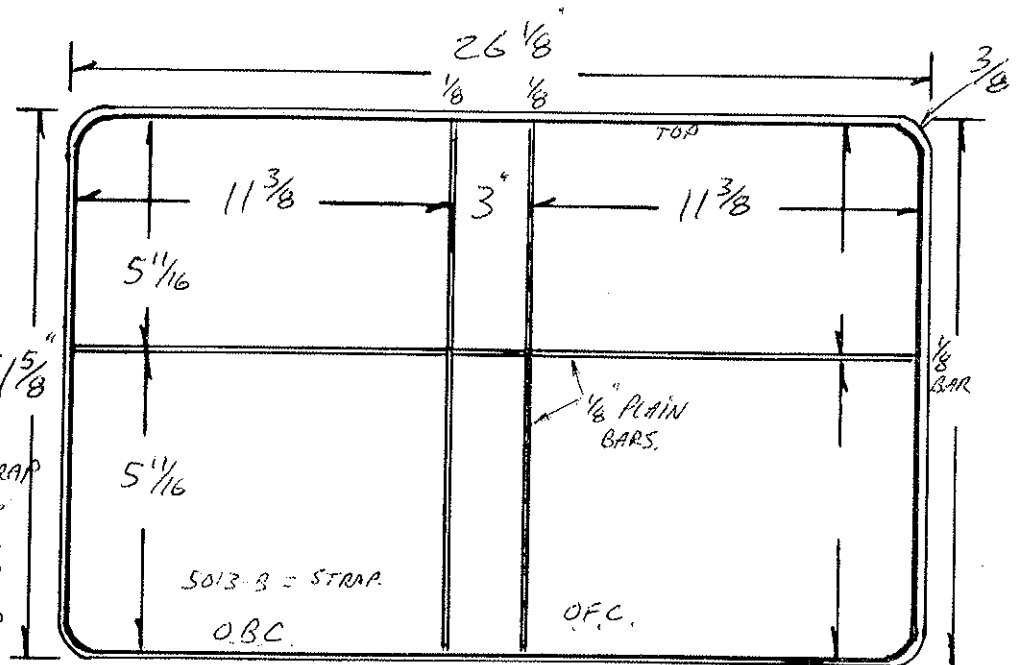

OWG. - B.Pace

Check-

PER SAMPLE

Code		Ga.	PCS	Size	Out	Cutting Specs	Code		Ga.	PCS	Size	Out	Cutting Specs
Cover Mat.	<i>A+B</i>			<i>12 1/4 x 29 3/8</i>	<i>14</i>	<i>1</i>	Lining Mat.	<i>A+B</i>			<i>12 1/4 x 29 3/8</i>	<i>14</i>	<i>1</i>
Cover Mat.	<i>7 1/2 x 3</i>			<i>15 1/2</i>			Lining Mat.				<i>X</i>		
Vert. Pckt.	<i>B</i>			<i>9 x 3</i>	<i>14</i>	<i>2</i>	Horz. Pckt.				<i>5 3/8 x 11 7/8</i>	<i>14</i>	<i>1</i>
Vert. Pckt.				<i>X</i>			Horz. Pckt.				<i>X</i>		
Pocket				<i>X</i>			Pocket				<i>X</i>		
Label Holder				<i>3 1/8 x 4</i>	<i>8</i>	<i>1</i>	Card Holder				<i>3 x 4 3/8</i>	<i>8</i>	<i>1</i>
Material				<i>X</i>			Material				<i>X</i>		
Material				<i>X</i>			Material				<i>X</i>		
Material				<i>X</i>			Material				<i>X</i>		
F.C. Board	<i>1-rc</i>			<i>5 9/16 x 11 1/4</i>	<i>120</i>	<i>2</i>	B.C. Board				<i>X</i>		
B.G. Board	<i>1-rc</i>			<i>5 9/16 x 11 1/4</i>	<i>120</i>	<i>2</i>	B.B. Board				<i>5 9/16 x 2 7/8</i>	<i>120</i>	<i>2</i>
Center Board				<i>X</i>			Board				<i>X</i>		
Board				<i>X</i>			Strip				<i>X</i>		
Cover Pad				<i>X</i>			Strip				<i>X</i>		
							B.B. Pad				<i>X</i>		
				<i>5 1/32 x 11 9/32</i>		<i>2</i>					<i>5 1/32 x 2 29/32</i>		<i>2</i>
				<i>5 1/32 x 11 9/32</i>		<i>2</i>							

Product Code

Style Case Split back Easel

Sheet Size 11 x 7 $\frac{3}{4}$

Cap. 1 $\frac{1}{2}$

Die No. 5253

Order No. 974141

Plate

Customer

B-control

Metal
Total Vinyl
Quantity 10680
Date 1-12-92
Type Corners RND
Radius 30
Completed

Gauge	Thick
Tear Seal .016	7/16
Bar Seal 253	1/8
Bar Seal	

No. of Feet	
Tear Seal	
Bar Seal	
Bar Seal	

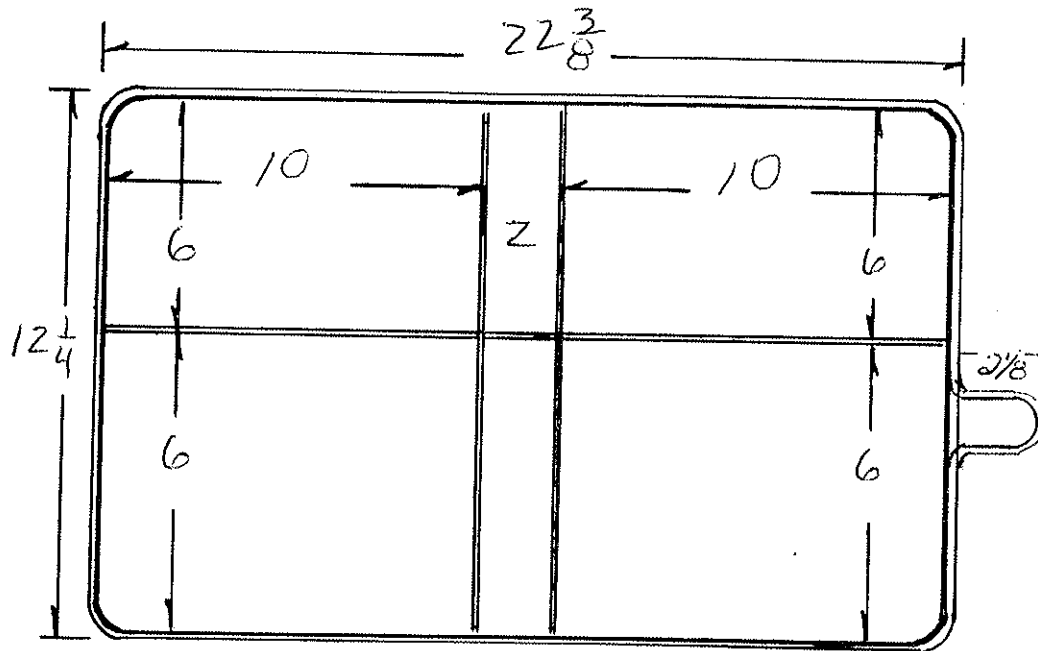

Use stock light duty strap

Code		Cutting Specs				Code		Cutting Specs			
		Ga.	#	Size	Out			Ga.	#	Size	Out
Cover Mat.	13 X 25 $\frac{1}{4}$		1			Lining Mat.	13 X 25 $\frac{1}{4}$		1		
Cover Mat	X					Lining Mat.	X				
Vert. Pckt.	X					Horz. Pckt.	X				
Vert. Pckt.	X					Horz. Pckt.	X				
Pocket	X					Pocket	Strap 2 X 9		2		
Label Holder	X					Card Holder	X				
Material	X					Material	X				
Material	X					Material	X				
Material	X					Material	X				
F.C. Board	5 $\frac{29}{32}$ X 9 $\frac{29}{32}$	120	Z			B.C. Board	X				
B.C. Board	5 $\frac{29}{32}$ X 9 $\frac{29}{32}$	120	Z			B.B. Board	X				
Center Board	5 $\frac{29}{32}$ X 1 $\frac{29}{32}$	120	Z			Board	X				
Board	X					Strip	X				
Cover Pad	X					Strip	X				
						B.B. Pad	X				

DIE #	5740 A-B	CAP.	1"	METAL	ROUND RING NB	(2 EYELET)
STYLE CASE	CM SPLITBACK EASEL			LOCATION	e-18-6	
SHEET SIZE	12 X 10 1/4			ORDER #	980263	
CUSTOMER	RSI DISTRIBUTION			DUE DATE	1-20-95	
QUANTITY	100	RADIUS	3/8		TEAR SEAL	.014
DATE	1-4-95	COMPLETED			BAR SEAL	254

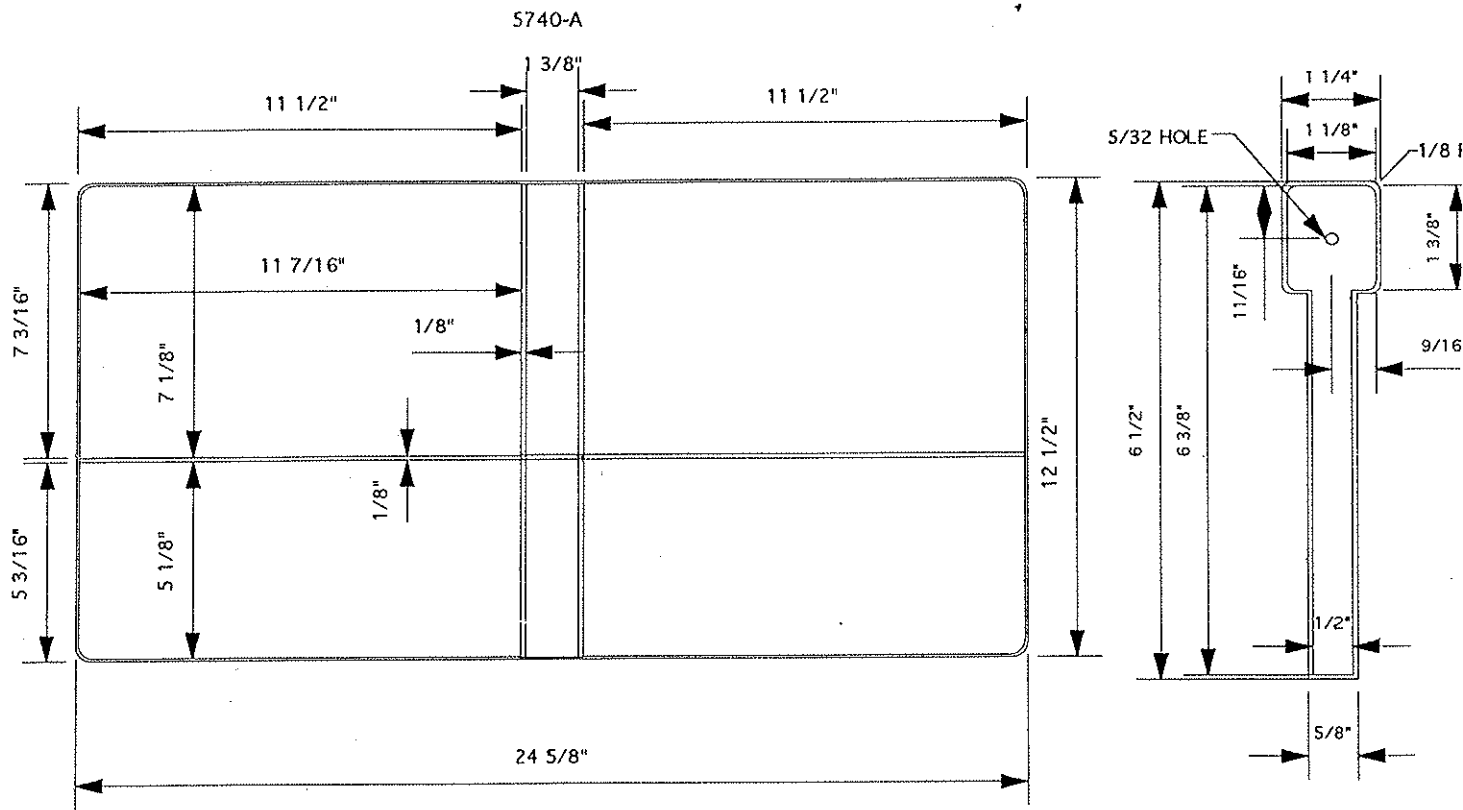

MATERIAL SPECS			GA	PCS	MATERIAL SPECS			GA	PCS
COVER MAT.	13 1/4 x 25 3/8			1	LINING MAT	13 1/4 X 25 3/8			1
COVER MAT.	7 1/4 X 2	.014 VINYL SNAKE		2	LINING MAT				
VERT PKT					HORZ PKT				
CARD HOLDER					GUSSET				
COL					DIAGONAL PKT				
LABEL HOLDER					REINF				

BOARD SPECS			GA	PCS	BOARD SPECS			GA	PCS
BOARD	7 1/32 X 11 1/32		100	2	BOARD	5 1/32 x 1 9/32	100	1	
BOARD	7 1/32 X 1 9/32		100	1	B.B. BOARD				
BOARD	5 1/32 X 11 1/32		100	2	B.C. BOARD				
POLY STRIP									
POLY STRIP	1 X 10 7/8	(TO BE FLAT CUT 55 ga.)		1					

DIE #	5763	CAP.	1"	METAL	1" ROUND RING
STYLE CASE	SPLIT BACK EASEL			LOCATION	
SHEET SIZE	11 x 9			ORDER #	
CUSTOMER	STOCK			DUE DATE	
QUANTITY		RADIUS	3/8	TEAR SEAL	.016
DATE	1-19-95	COMPLETED		BAR SEAL	178

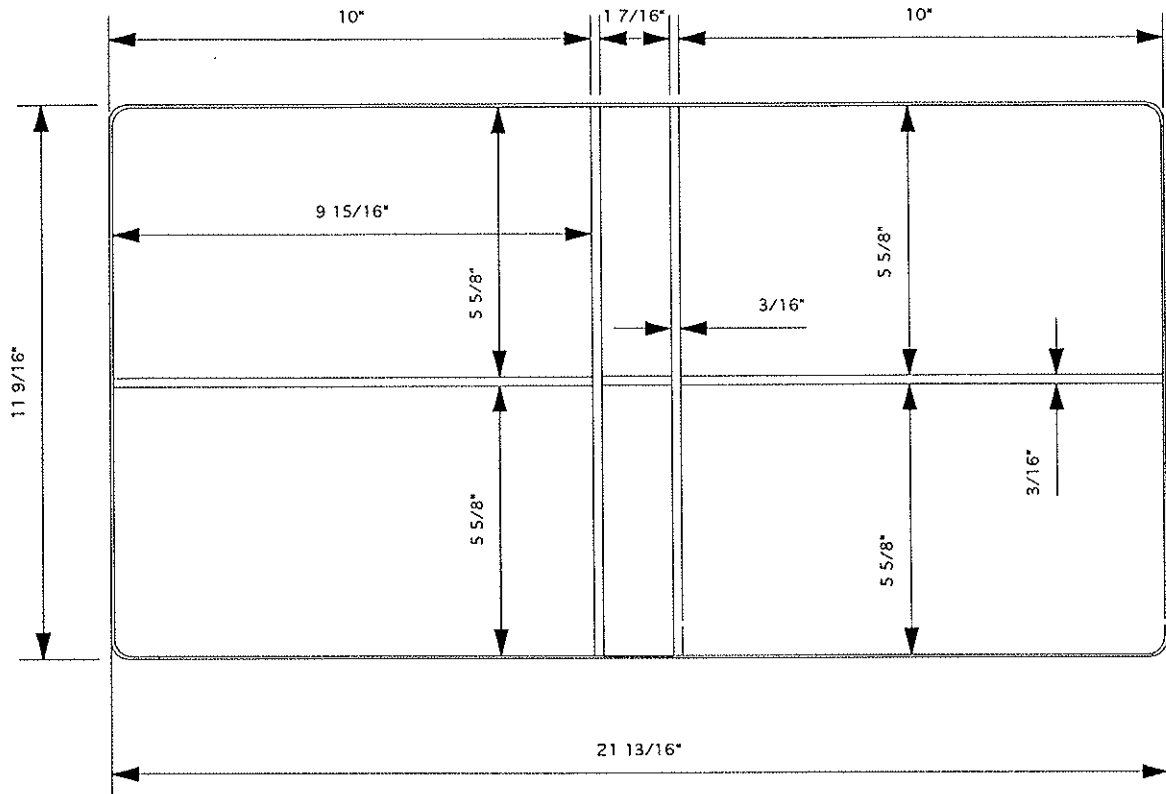

MATERIAL SPECS	GA	PCS	MATERIAL SPECS	GA	PCS
COVER MAT.	12 1/4 X 22 5/8	1	LINING MAT	12 1/4 X 22 5/8	1
COVER MAT.			LINING MAT		
STRAP	9 X 2 1/2	1	HORZ PKT		
CARD HOLDER			GUSSET		
COL			DIAGONAL PKT		
LABEL HOLDER			REINF		

BOARD SPECS					
100 PT. BOARD					
FC BOARD	5 9/16 X 9 7/8	2	FC BOARD	5 17/32 X 9 27/32	2
BB BOARD	5 9/16 X 1 11/32	2	BB BOARD	5 17/32 X 1 11/32	2
BC BOARD	5 9/16 X 9 7/8	2	BC BOARD	5 17/32 X 9 27/32	2
Padded FC-BB-BC Die 5762B					
14 3/8 x 21 3/16					

DIE #	5996	METAL	NB ROUND RING	RADIUS	3/8"
ORDER #	983699	CUSTOMER	OLAN MILLS INC	TEAR SEAL	.014
SHEET SIZE	11 1/2 X 9	STYLE CASE	SPLITBACK EASEL	BAR SEAL	253
CAP.	1"	DUE DATE	2-2-96	COMPLETED	
LOCATION	F-3-4	QUANTITY	2	DATE	1-29-9

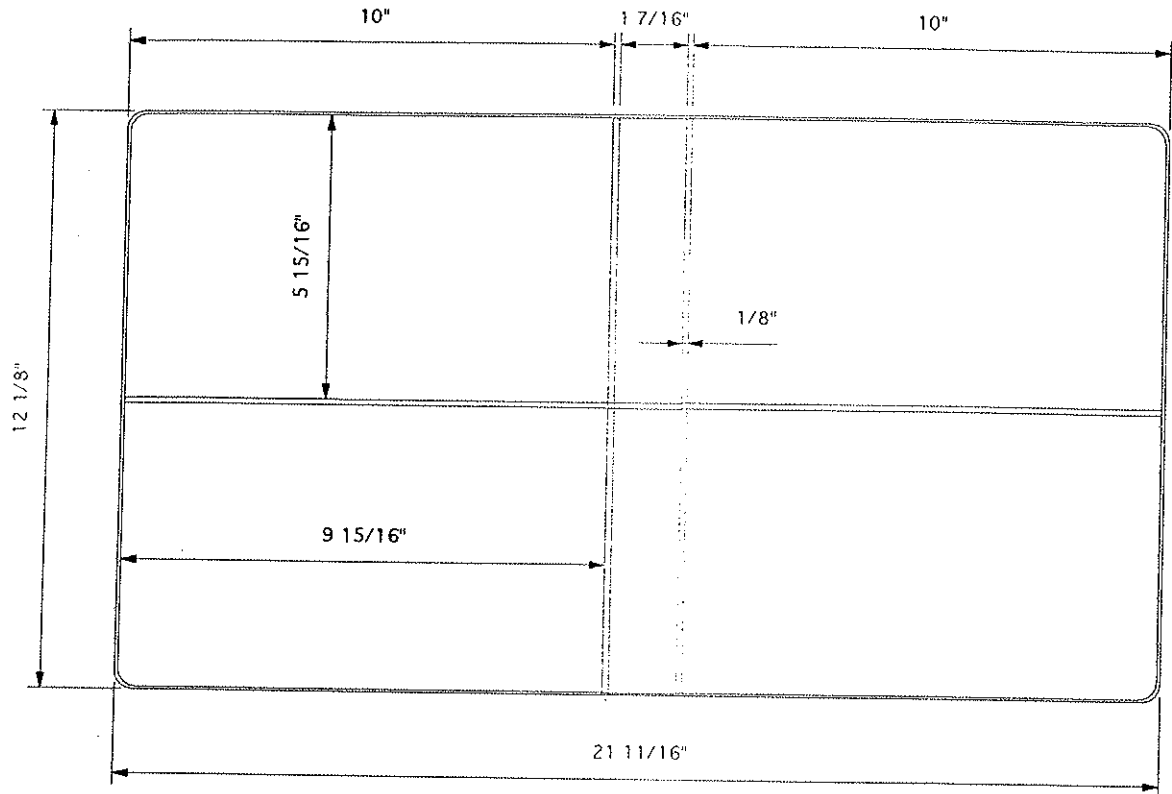

MATERIAL SPECS		GAUGE PCS.		MATERIAL SPECS		GAUGE	
COVER MAT.	13 1/8 X 22 11/16		1	LINING MAT.	12 7/8 X 22 1/2		
COVER MAT.				LINING MAT.			
DIE CUT				HORZ. PKT.			
COL				VERT. PKT.			
LABEL HOLDER				DIE CUT			
GUSSET				REINF.			

BOARD SPECS		GAUGE PCS.		BOARD SPECS		GAUGE	
POLY STRIP			1	F.C. BOARD			
POLY STRIP			1	B.B. BOARD			
B.C. BOARD				B.C. BOARD			
B.U. STRIP				DIE CUT			
DIE CUT	15 X 21 1/4	DIE 5996-A	100	DIE CUT			

DIE #	6084	METAL	3" RR	RADIUS	3/8
ORDER #	73624	CUSTOMER	MAYER ELECTRIC	TEAR SEAL	.014
SHEET SIZE	11 X 9	STYLE CASE	VINYL RING BINDER	BAR SEAL	253-254
CAP.	3"	DUE DATE	7-3-96	COMPLETED	
LOCATION		QUANTITY	50	DATE	6-27-96

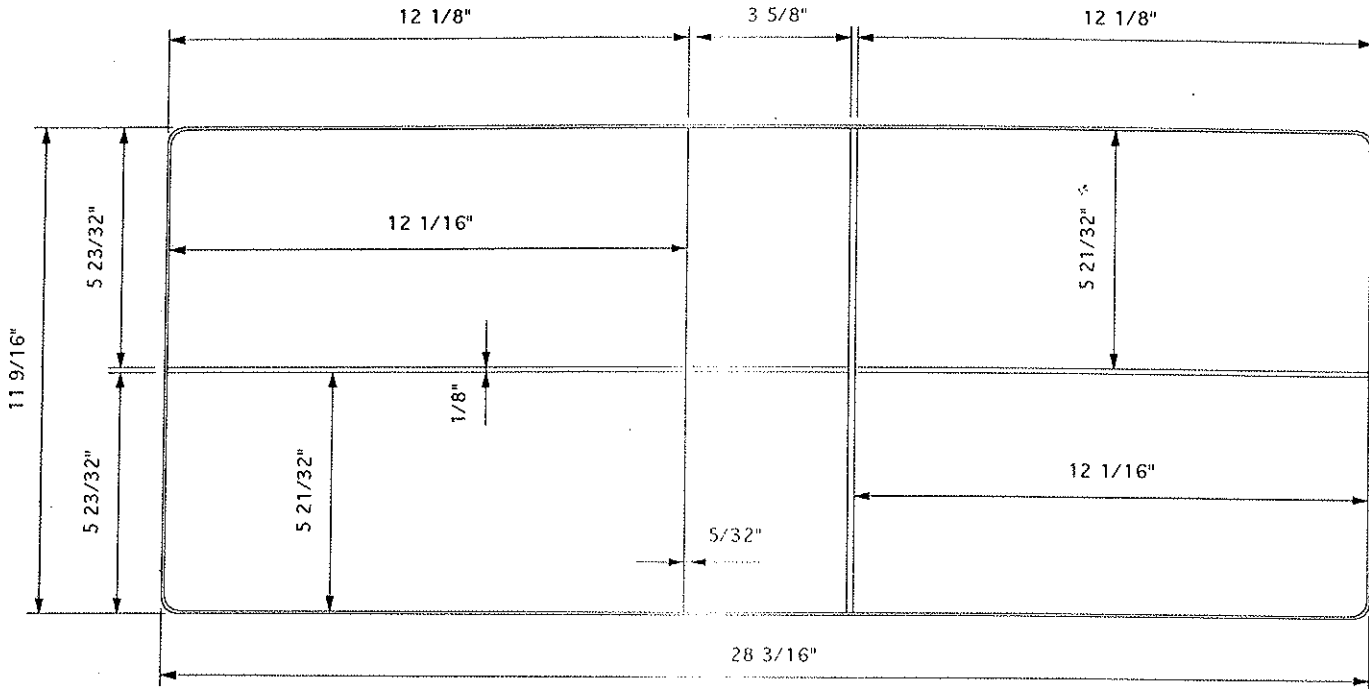

Snake Die L311

MATERIAL SPECS		GAUGE		PC.		MATERIAL SPECS		GAUGE		PC.	
COVER MAT.	12 5/16 X 29		1	LINING MAT.	12 5/16 X 29		1				
COVER MAT.				LINING MAT.							
DIE CUT				HORZ. PKT.							
COL				VERT. PKT.							
LABEL HOLDER				DIE CUT							
GUSSET				REINF.							
BOARD SPECS		GAUGE		PC.		BOARD SPECS		GAUGE		PC.	
F.C. BOARD	5 9/16 X 11 31/32	120	2	Poly	11 X 1 3/4	55ga	Poly				
B.B. BOARD	5 9/16 X 3 17/32	120	2	B.B. BOARD							
B.C. BOARD	5 9/16 X 11 31/32	120	2	B.C. BOARD							
FLAP BD.				DIE CUT							
BOARD				DIE CUT							

DIE #	6247	METAL	HOC W/EYELET RR 14"	RADIUS	3/8"
ORDER #	987218	CUSTOMER	PEPITONE BERKSHIRE	TEAR SEAL	.014
SHEET SIZE	14 X 9	STYLE CASE	VINYL SPLITBACK EASEL	BAR SEAL	253
CAP.	2 1/2"	DUE DATE	5-22-97	COMPLETED	
LOCATION	L-4-2	QUANTITY	200	DATE	5-14-97

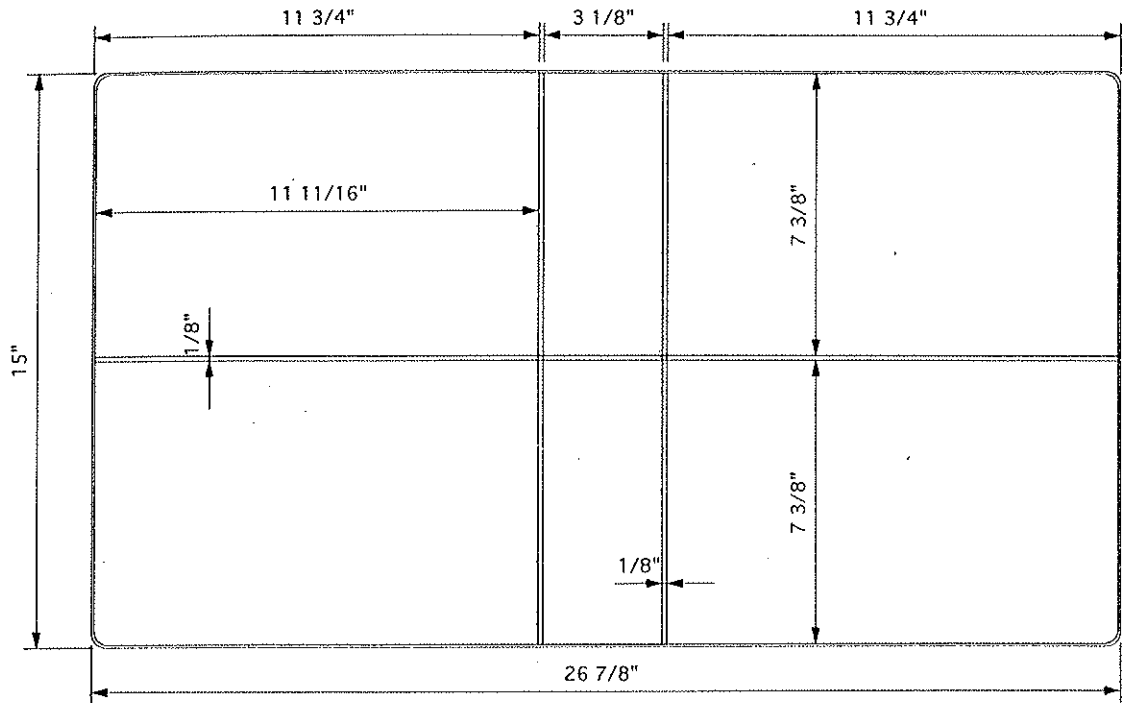

DIE 6247-A

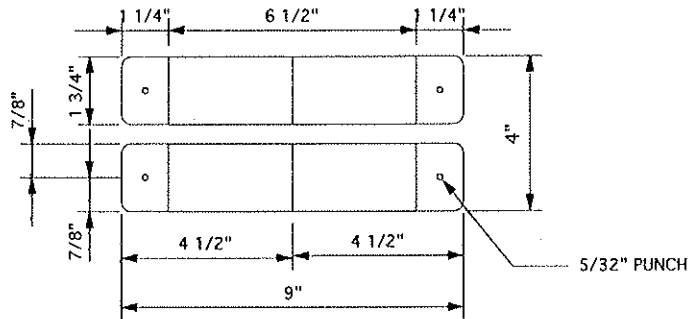

MATERIAL SPECS		GAUGE	PCS.	MATERIAL SPECS		GAUGE
COVER MAT.	16 X 27 7/8		1	LINING MAT.	15 3/4 X 27 5/8	
COVER MAT.				LINING MAT.		
DIE CUT				HORZ. PKT.		
COL				VERT. PKT.		
LABEL HOLDER				DIE CUT	5 X 10	DIECUT 6247-A (2 OUT) 23 ga. POLY
GUSSET				REINF.	14 3/8 X 1 3/4	55 ga. POLY

BOARD SPECS		GAUGE	PCS.	BOARD SPECS		GAUGE
F.C. BOARD	7 9/32 X 11 19/32	120	2	F.C. BOARD		
B.B. BOARD	7 9/32 X 3 1/32	120	2	B.B. BOARD		
B.C. BOARD	7 9/32 X 11 19/32	120	2	B.C. BOARD		
FLAP BD.				DIE CUT		
BOARD				DIE CUT		

DIE #	6278	METAL	HOC EASEL	RADIUS	3/8"
ORDER #	987595	CUSTOMER	KWIK KOPY	TEAR SEAL	.014
SHEET SIZE	8.5 X 6	STYLE CASE	VRB SPLITBACK	BAR SEAL	253
CAP.	1 1/2"	DUE DATE	7-25-97	COMPLETED	
LOCATION	H-2-6	QUANTITY	2000	DATE	7-8-97

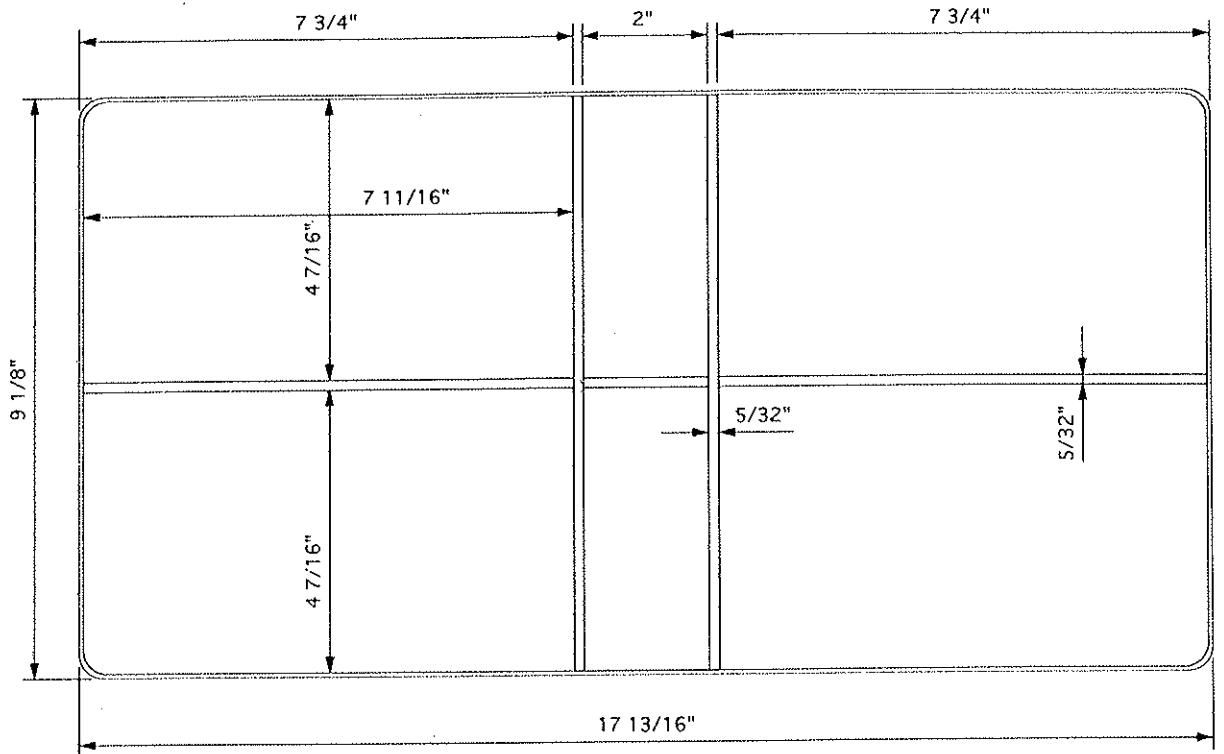

MATERIAL SPECS		GAUGE		PCS.		MATERIAL SPECS		GAUGE	
COVER MAT.	9 7/8 X 18 5/8			1		LINING MAT.	9 7/8 X 18 5/8		
COVER MAT.						LINING MAT.			
DIE CUT						HORZ. PKT.			
COL						VERT. PKT.			
LABEL HOLDER						DIE CUT			
GUSSET						STRAP	9 X 2 1/2		
BOARD SPECS		GAUGE		PCS.		BOARD SPECS		GAUGE	
F.C. BOARD	4 11/32 X 7 19/32	100	2			F.C. BOARD			
B.B. BOARD	4 11/32 X 1 29/32	100	2			B.B. BOARD			
B.C. BOARD	4 11/32 X 7 19/32	100	2			B.C. BOARD			
FLAP BD.						DIE CUT			
BOARD						DIE CUT			

DIE #	6343	METAL	8 1/2" LOC	RADIUS	1/4"
ORDER #	988296	CUSTOMER	PITNEY BOWES	TEAR SEAL	.014
SHEET SIZE	9 X 7 1/2	STYLE CASE	VINYL SPLITBACK EASEL	BAR SEAL	253
CAP.	1 1/2"	DUE DATE	10-29-97	COMPLETED	
LOCATION	1-3-4	QUANTITY	5000	DATE	10-7-97

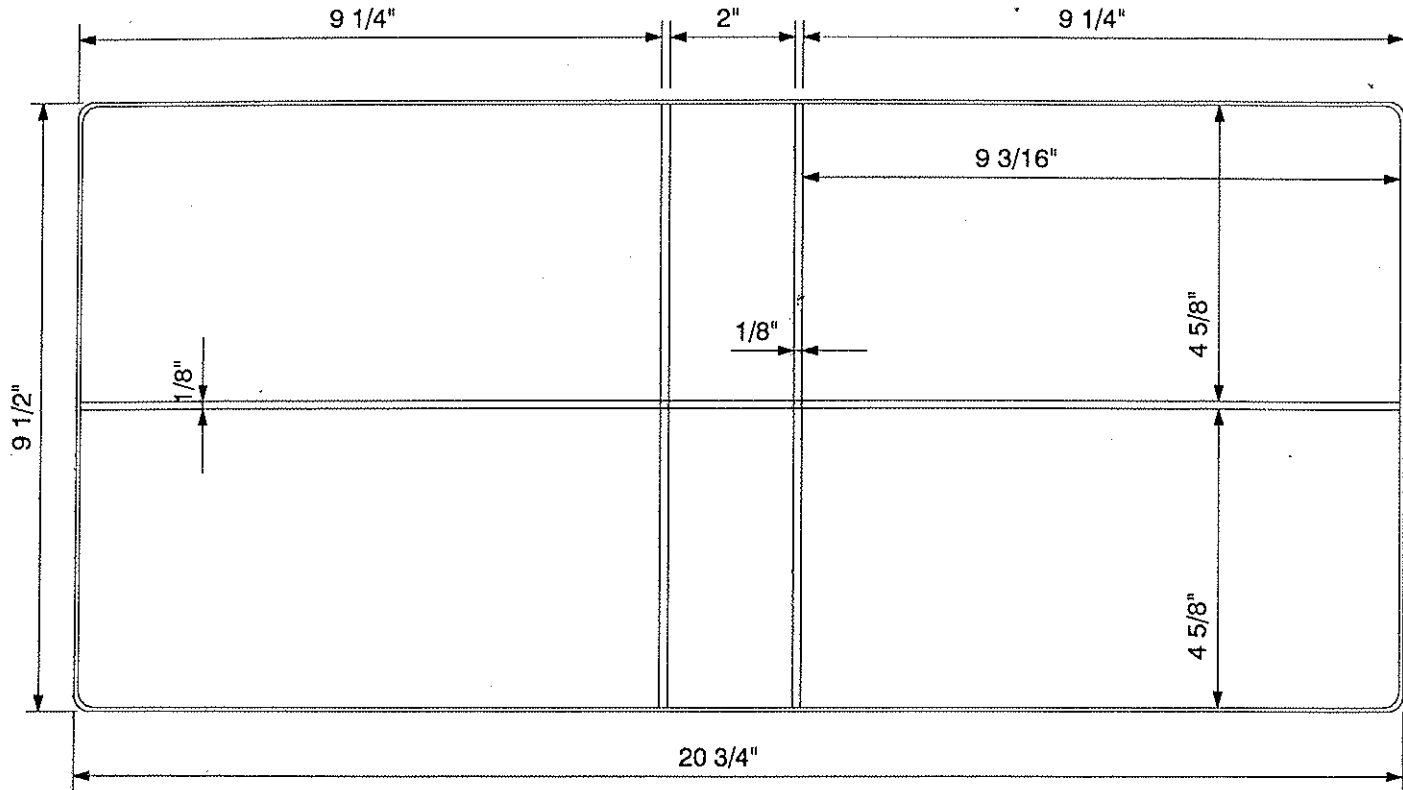

MATERIAL SPECS		GAUGE PCS.		MATERIAL SPECS		GAUGE PCS.	
COVER MAT.	10 1/4 X 21 1/2		1	LINING MAT.	10 1/4 X 21 1/2		1
COVER MAT.				LINING MAT.			
DIE CUT				HORZ. PKT.			
COL	4 11/16 X 12		1	VERT. PKT.			
LABEL HOLDER				DIE CUT			
GUSSET				REINF. STRAP	9 X 2 1/2		2

BOARD SPECS		GAUGE PCS.		BOARD SPECS		GAUGE PCS.	
F.C. BOARD	4 17/32 X 9 3/32	100	2	F.C. BOARD			
B.B. BOARD	4 17/32 X 1 29/32	100	2	B.B. BOARD			
B.C. BOARD	4 17/32 X 9 3/32	100	2	B.C. BOARD			
FLAP BD.				DIE CUT			
BOARD				DIE CUT			

DIE #	6396	METAL	LOC 3RD EYELET	RADIUS	3/8"
ORDER #	988850	CUSTOMER	PITNEY BOWES	TEAR SEAL	.010
SHEET SIZE	8.5 X 6.5	STYLE CASE	VRB SPLITBACK EASEL	BAR SEAL	178
CAP.	1 1/2-1 1/4	DUE DATE	1-12-98	COMPLETED	
LOCATION	G-12-8	QUANTITY	5000	DATE	12-17-97

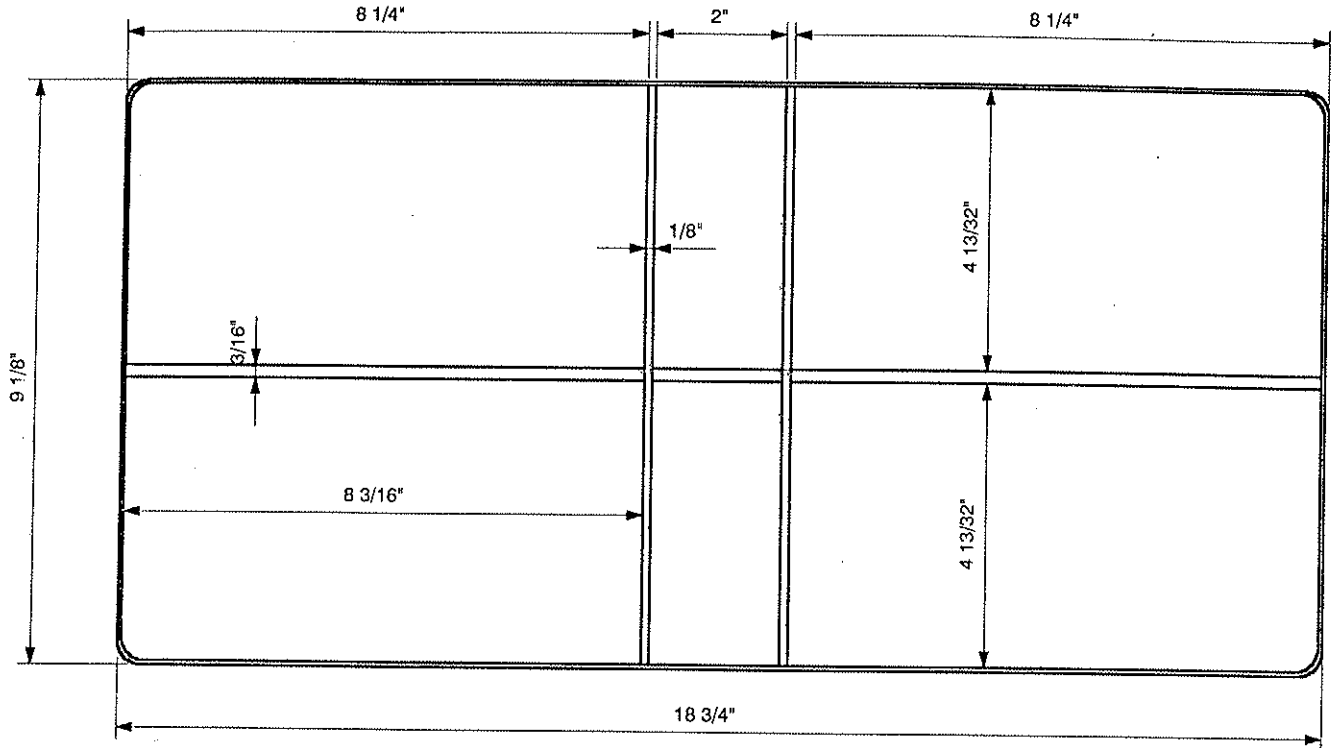

MATERIAL SPECS		GAUGE		PCS.		MATERIAL SPECS		GAUGE	
COVER MAT.	9 7/8 X 19 1/2			1		LINING MAT.	9 7/8 X 19 1/2		
COVER MAT.						LINING MAT.			
DIE CUT						HORZ. PKT.	4 1/8 X 19 1/2		
COL	4 3/8 X 10 7/8			1		VERT. PKT.			
LABEL HOLDER						DIE CUT			
GUSSET						REINF.			
BOARD SPECS		GAUGE		PCS.		BOARD SPECS		GAUGE	
F.C. BOARD	4 5/16 X 8 3/32	100	2			F.C. BOARD			
B.B. BOARD	4 5/16 X 1 29/32	100	2			B.B. BOARD			
B.C. BOARD	4 5/16 X 8 3/32	100	2			B.C. BOARD			
FLAP BD.						DIE CUT			
BOARD						DIE CUT			

DIE #	6738	METAL	EASEL LOC W/B	RADIUS	3/8"
ORDER #	261585	CUSTOMER	FOR YOUR EARS ONLY	TEAR SEAL	.012
SHEET SIZE	11 X 9 3/4	STYLE CASE	VINYL SPLITBACK EASEL	BAR SEAL	178
CAP.	1"	DUE DATE	8-24-99	COMPLETED	
LOCATION	I-13-8	QUANTITY	5000	DATE	8-4-99

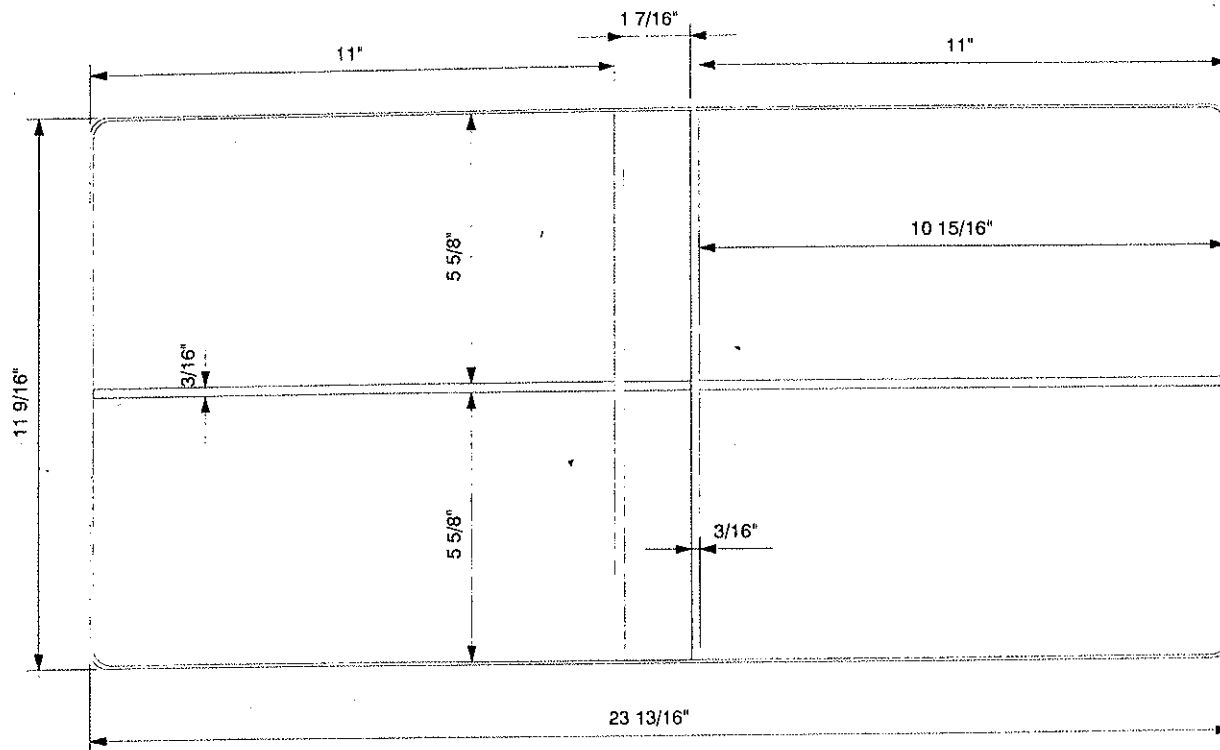

MATERIAL SPECS		GAUGE	PCS.	MATERIAL SPECS		GAUGE	PCS.
COVER MAT.	12 3/8 X 24 5/8		1	LINING MAT.	12 3/8 X 24 5/8		1
COVER MAT.				LINING MAT.			
DIE CUT				HORZ. PKT.	4 7/8 X 24 5/8		1
Strap Strap	2 x 9			VERT. PKT.			
LABEL HOLDER				DIE CUT			
GUSSET				REINF.			
BOARD SPECS		GAUGE	PCS.	BOARD SPECS		GAUGE	PCS.
F.C. BOARD	5 17/32 X 10 27/32		100	F.C. BOARD	5/16" R. CORNERS		
B.B. BOARD	5 17/32 X 1 11/32		100	B.B. BOARD			
B.C. BOARD	5 17/32 X 10 27/32		100	B.C. BOARD			
FLAP BD.				DIE CUT			
BOARD				DIE CUT			

DIE #	6625	METAL		RADIUS	3/8"
ORDER #		CUSTOMER		TEAR SEAL	.012
SHEET SIZE	11 x 9	STYLE CASE	SPLITBACK EASEL	BAR SEAL	48-3
CAP.	1"	DUE DATE		COMPLETED	
LOCATION	1-9-4	QUANTITY		DATE	1-13-99

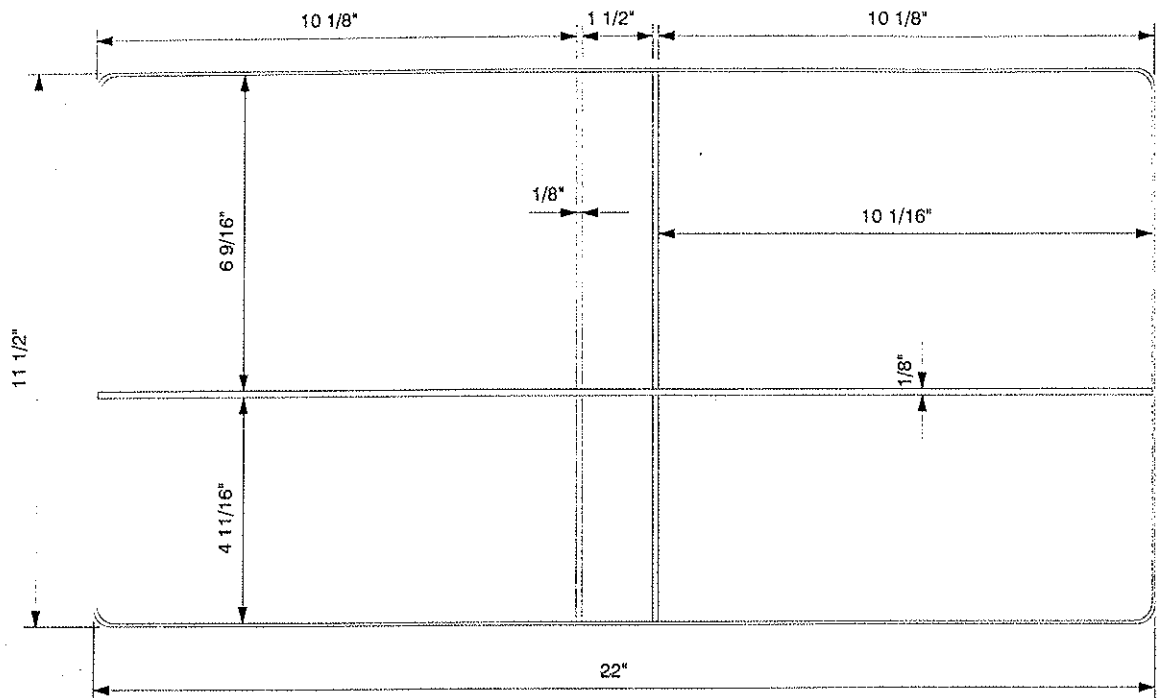

MATERIAL SPECS		GAUGE	PCS.	MATERIAL SPECS		GAUGE
COVER MAT.	12 1/4 X 22 3/4		1	LINING MAT.	12 1/4 X 22 3/4	
COVER MAT.				LINING MAT.		
DIE CUT				HORZ. PKT.		
COL				VERT. PKT.		
LABEL HOLDER				DIE CUT		
GUSSET				REINF.		
BOARD SPECS		GAUGE	PCS.	BOARD SPECS		GAUGE
	5/16" R. CORNERS				5/16" R. CORNERS	
F.C. BOARD	6 15/32 X 9 31/32		1	F.C. BOARD	4 19/32 X 9 31/32	
B.B. BOARD	6 15/32 X 9 31/32		1	B.B. BOARD	4 19/32 X 9 31/32	
B.C. BOARD	6 15/32 X 9 31/32		1	B.C. BOARD	4 19/32 X 9 31/32	
FLAP BD.				DIE CUT		
BOARD				DIE CUT		

DIE #	7351-R	METAL	RR NB	RADIUS	3/8"
ORDER #	523071	CUSTOMER	ANGIE ROBERTSON	TEAR SEAL	.014
SHEET SIZE	9 1/4 X 7 3/4	STYLE CASE	VINYL SPLITBACK EASEL	BAR SEAL	254
CAP.	1 1/2"	DUE DATE	11-29-02	COMPLETED	
LOCATION		QUANTITY	500	DATE	11-14-02

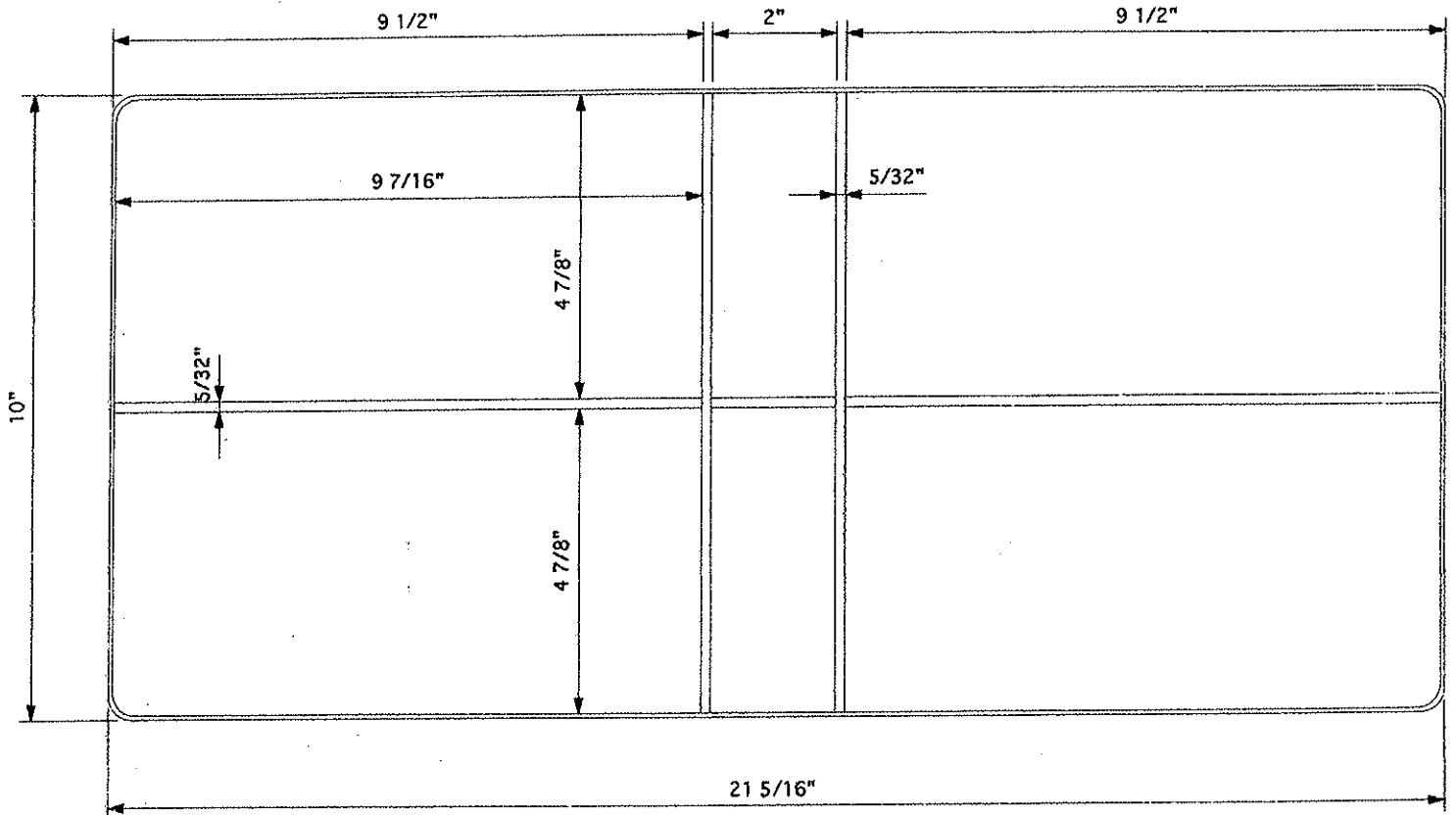

MATERIAL SPECS		GAUGE	PCS.	MATERIAL SPECS		GAUGE	PCS.
COVER MAT.	11 X 22 3/8		1	LINING MAT.	10 3/4 X 22 1/8		1
COVER MAT.				LINING MAT.			
DIE CUT				HORZ. PKT.			
COL				VERT. PKT.			
LABEL HOLDER				DIE CUT			
GUSSET				REINF.			
BOARD SPECS		GAUGE	PCS.	BOARD SPECS		GAUGE	PCS.
5/16" R. CORNERS				5/16" R. CORNERS			
F.C. BOARD	4 25/32 X 9 11/32	100	2	F.C. BOARD			
B.B. BOARD	4 25/32 X 1 29/32	100	2	B.B. BOARD			
B.C. BOARD	4 25/32 X 9 11/32	100	2	B.C. BOARD			
FLAP BD.				DIE CUT			
BOARD				DIE CUT			

DIE #	7839	METAL	LOC	RADIUS	3/8"
ORDER #	664106	CUSTOMER	FINNACLE GRAPHICS	TEAR SEAL	
SHEET SIZE	11 X 9	STYLE CASE	VINYL SPLITBACK EASEL	BAR SEAL	
CAP.	1/2"	DUE DATE	3-11-05	COMPLETED	
LOCATION		QUANTITY	100	DATE	2-17-05

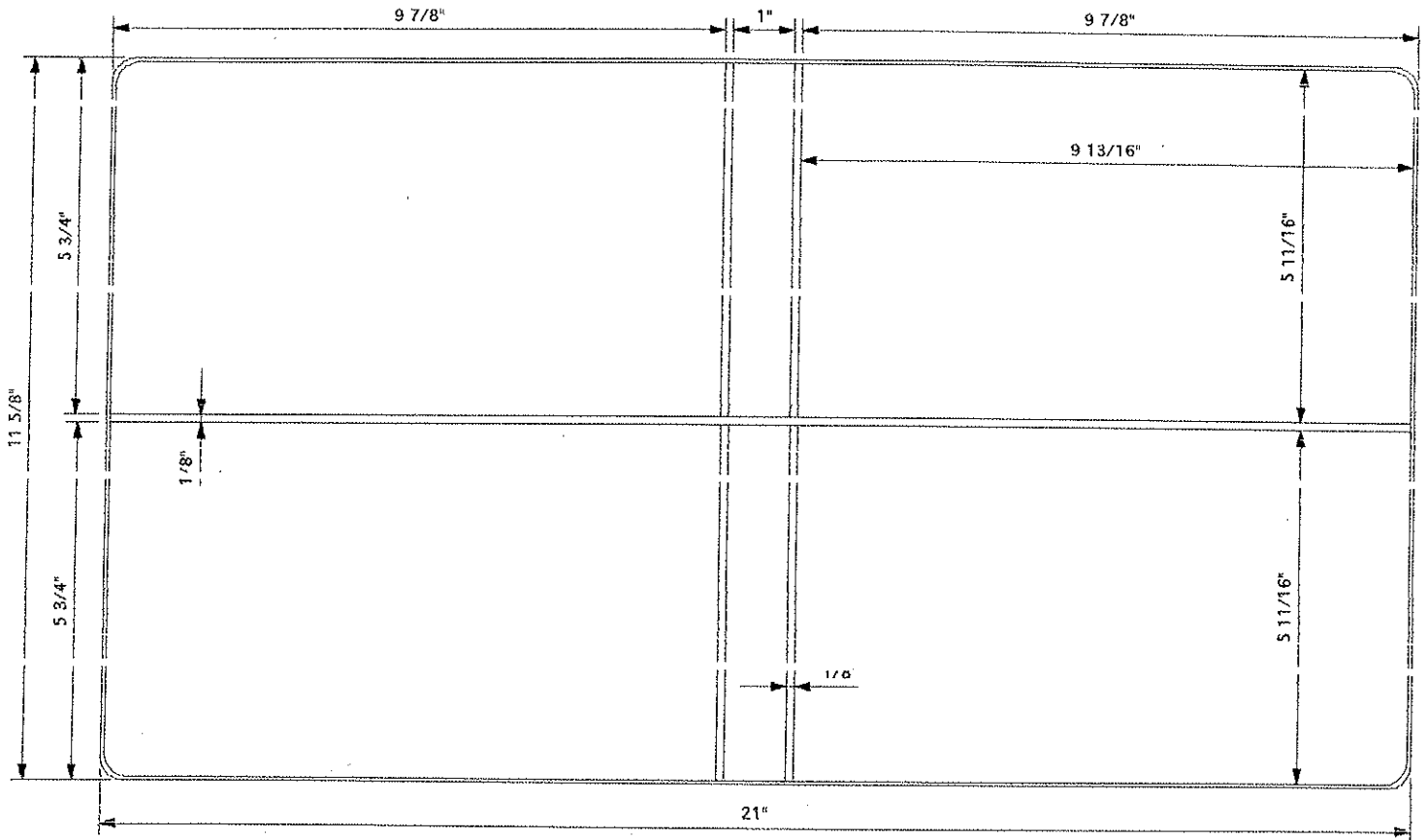

MATERIAL SPECS		GAUGE		MATERIAL SPECS		GAUGE	
COVER MAT.	12 3/8 X 21 3/4		1	LINING MAT.	12 3/8 X 21 3/4		1
COVER MAT.				LINING MAT.			
COL	5 11/16 X 21 3/4		1	HORZ. PKT.			
COL	6 X 21 3/4		1	VERT. PKT.			
LABEL HOLDER				DIE CUT			
GUSSET				REINF.			
BOARD SPECS		GAUGE		BOARD SPECS		GAUGE	
5/16" R. CORNERS				5/16" R. CORNERS			
F.C. BOARD	5 9/16 X 9 11/16	100	2	F.C. BOARD			
B.B. BOARD	5 9/16 X 7/8	100	2	B.B. BOARD			
B.C. BOARD	5 9/16 X 9 11/16	100	2	B.C. BOARD			
FLAP BD.				DIE CUT			
BOARD				DIE CUT			

DIE #	8029	METAL	NB RR	RADIUS	3/8"
ORDER #	705220	CUSTOMER	TRANSPRINT USA	TEAR SEAL	.014
SHEET SIZE	11 3/8 X 10	STYLE CASE	VINYL SPLITBACK EASEL	BAR SEAL	48-4
CAP.	1 1/2"	DUE DATE	12-13-05	COMPLETED	
LOCATION		QUANTITY	100	DATE	12-1-05

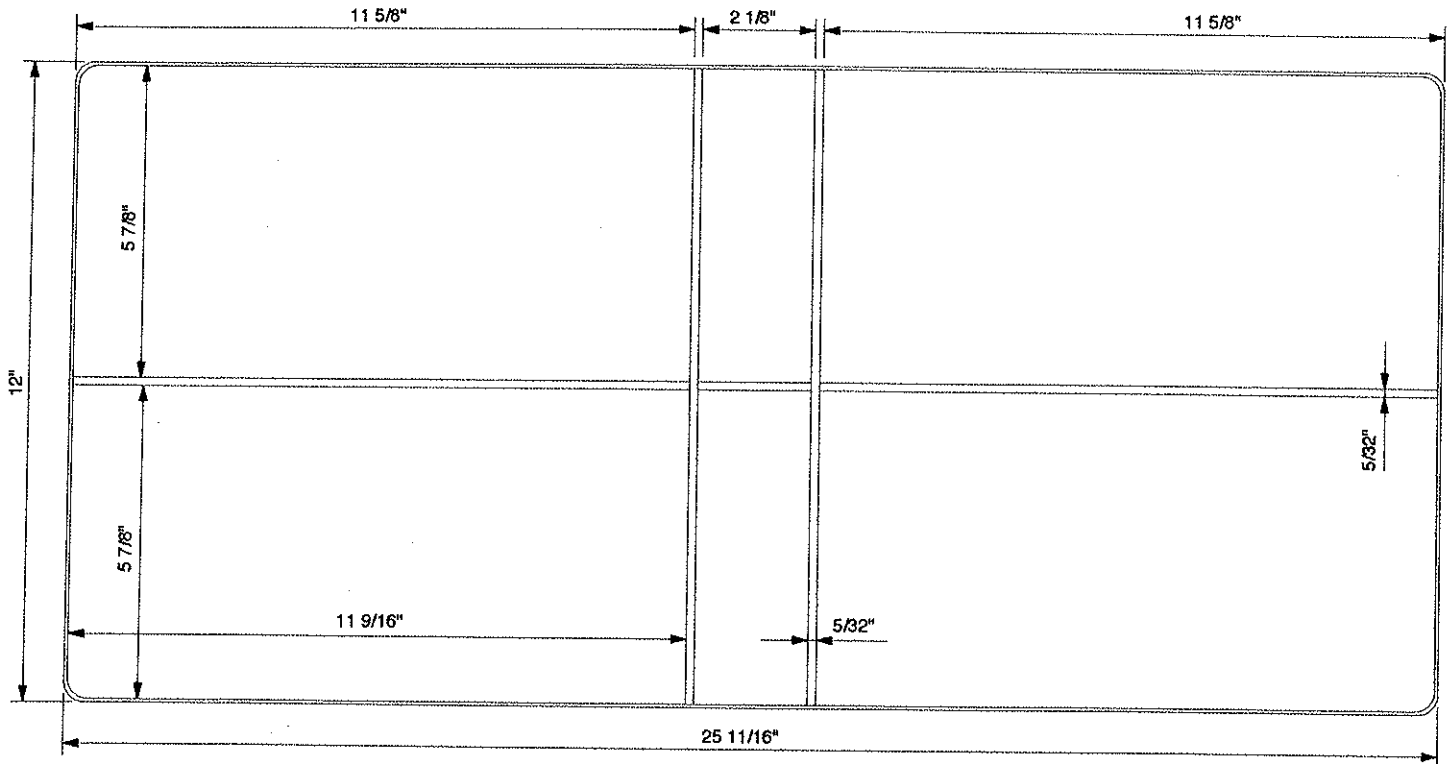

MATERIAL SPECS		GAUGE	PCS.	MATERIAL SPECS		GAUGE	PCS.
COVER MAT.	12 3/4 X 26 1/2		1	LINING MAT.	12 3/4 X 26 1/2		1
COVER MAT.				LINING MAT.			
DIE CUT				HORZ. PKT.			
COL				VERT. PKT.			
LABEL HOLDER				DIE CUT			
GUSSET				REINF.	Snake 4011		
BOARD SPECS		GAUGE	PCS.	BOARD SPECS		GAUGE	PCS.
F.C. BOARD	5 25/32 X 11 15/32	120	2	F.C. BOARD	5/16" R. CORNERS		
B.B. BOARD	5 25/32 X 2 1/32	120	2	B.B. BOARD			
B.C. BOARD	5 25/32 X 11 15/32	120	2	B.C. BOARD			
FLAP BD.				DIE CUT			
BOARD	5 3/4 X 2	22	2	DIE CUT			