

DIE #	3564	CAP.	1"	METAL	1" RND RING
STYLE CASE	VINYL BINDER W/FLAP			LOCATION	
SHEET SIZE	8 1/2 X 6			ORDER #	980587
CUSTOMER	SRS DISPLAYS			DUE DATE	2-6-95
QUANTITY		RADIUS	3/8	TEAR SEAL	.014
DATE	2-2-95	COMPLETED		BAR SEAL	102

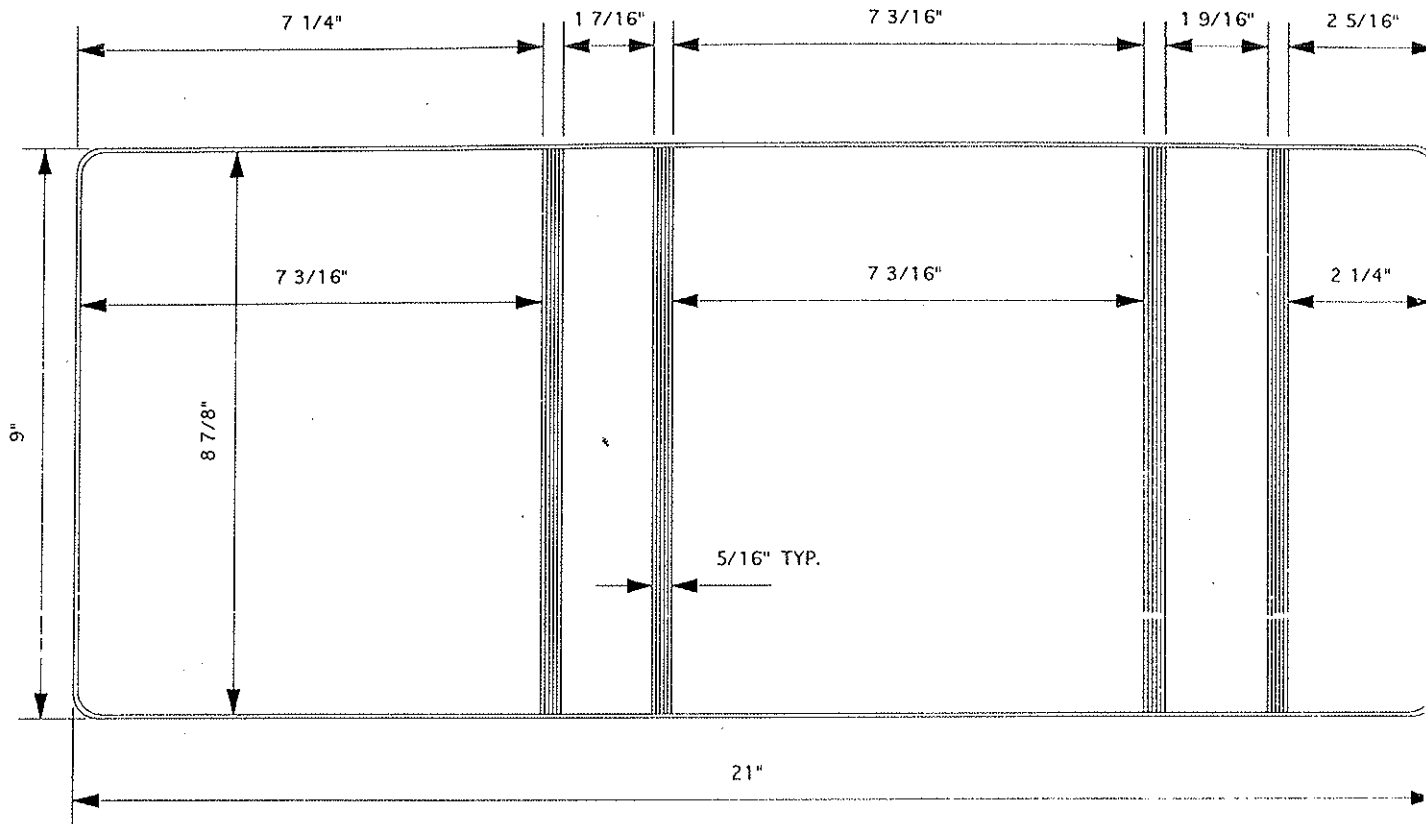

MATERIAL SPECS		GA	PCS			GA	PCS
COVER MAT.	9 3/4 X 21 3/4		1	LINING MAT	9 3/4 X 21 3/4		1
COVER MAT.				LINING MAT			
VERT PKT				HORZ PKT			
CARD HOLDER				GUSSET			
COL				DIAGONAL PKT			
LABEL HOLDER				REINF			

BOARD SPECS (PADDED BOARD)				GA	PCS			GA	PCS
F.C. BOARD	8 25/32 X 7 3/32	100	1	BB. BOARD	8 25/32 X 1 1/2	100	1		
B.B. BOARD	8 25/32 X 1 11/32	100	1	FLAP BOARD	8 25/32 X 2 3/16	100	1		
B.C. BOARD	8 25/32 X 7 3/32	100	1						
B.U. STRIP									

Product Code

Style Case *VRB w/flap 2" Hoc*

Sheet Size *11 X 9*

Cap. *2* Die No. *3993*

Order No. *958546*

Plate

Customer

Alpha Omicron PI

Metal
Total Vinyl <i>.030</i>
Quantity <i>500</i>
Date <i>5/15/88</i>
Type Corners <i>Rd.</i>
Radius <i>1/4</i>
Completed

Gauge	Thick
Tear Seal <i>.016</i>	<i>1/32</i>
Bar Seal <i>.178</i>	<i>3/16</i>
Bar Seal	

No. of Feet	
Tear Seal	
Bar Seal	
Bar Seal	

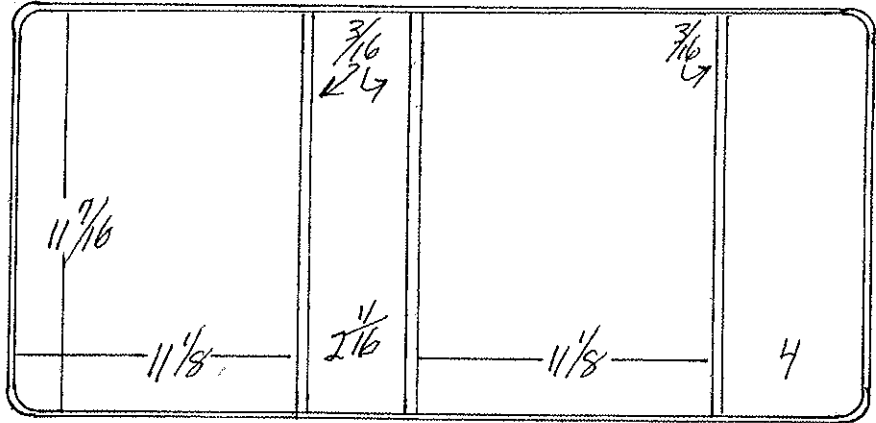

This die HAS NO CAP. FOR PAPER 1/2" STACK OF PAPER max.

29 5/8

Code		Cutting Specs				Code		Cutting Specs			
Ga.	PCS	Size	Out	Ga.	PCS	Size	Out	Ga.	PCS	Size	Out
Cover Mat.		<i>12 1/4 X 30 1/4</i>		<i>1</i>	Lining Mat.		<i>12 1/4 X 30 1/4</i>		<i>1</i>		
Cover Mat		<i>12 7/16 X 30 5/8</i>			Lining Mat.		X				
Vert. Pckt.		X			Horz. Pckt.		X				
Vert. Pckt.		X			Horz. Pckt.		<i>5 3/8 X 11 1/16</i>		<i>1</i>		
Pocket		X			Pocket		X				
Label Holder		X			Card Hlder		X				
Material		X			Material		X				
Material		X			Material		X				
Material		X			Material		X				
F.C. Board		<i>11 1/32 X 11 1/32</i>		<i>1</i>	B.C. Board		<i>11 1/32 X 11 1/32</i>		<i>1</i>		
B.G. Board		<i>11 1/32 X 3 29/32</i>			B.B. Board		<i>11 1/32 X 2 9/32</i>				
Center Board		X			Board		X				
Board		<i>Padded Bl Cutting Die 3993-B</i>			Strip		X				
Cover Pad		<i>16 3/4 X 23 9/16</i>			Strip		X				
					B.B. Pad		X				

Product Code

Style Case *Ring Binder w/flat*

Sheet Size *11 X 9* Cap. *1 1/2* Die No. *4015* Order No. *958751* Plate

Customer

Alpha Omicron Pi

Metal
Total Vinyl <i>.030</i>
Quantity <i>500</i>
Date <i>5/15/88</i>
Type Corners <i>R0</i>
Radius <i>1/4</i>
Completed

	Gauge	Thick
Tear Seal	<i>.016</i>	<i>3/32</i>
Bar Seal	<i>178</i>	<i>3/16</i>
Bar Seal		

	No. of Feet
Tear Seal	
Bar Seal	
Bar Seal	

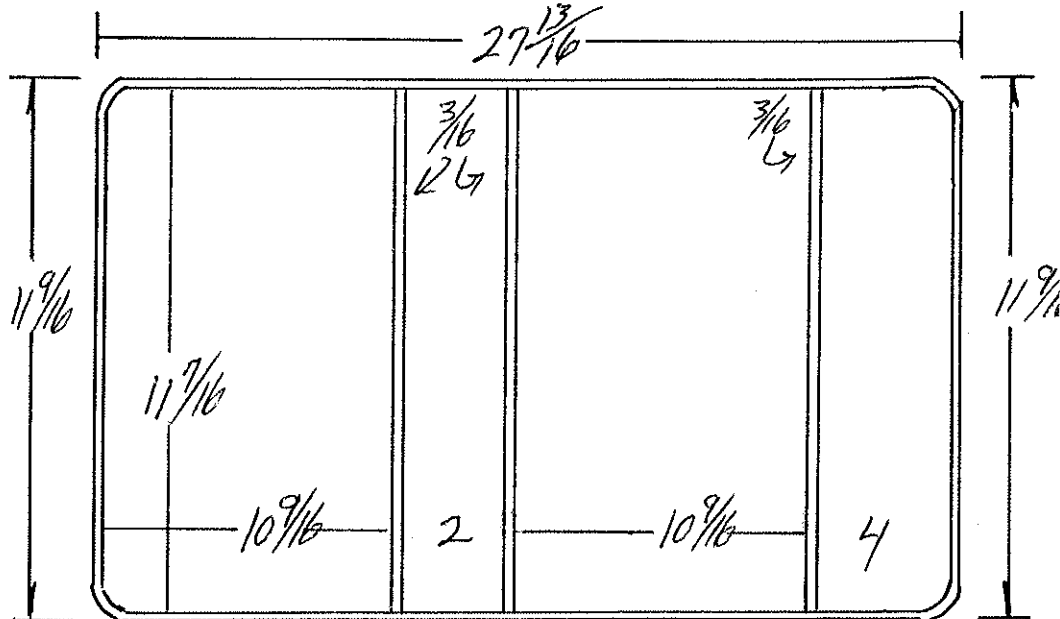

Code	Ga.	# PCS	Cutting Specs		Code	Ga.	# PCS	Cutting Specs	
			Size	Out				Size	Out
Cover Mat.			<i>12 3/16 X 28 7/16</i>		Lining Mat.			<i>12 3/16 X 28 7/16</i>	<i>1</i>
Cover Mat			X		Lining Mat.			X	
Vert. Pckt.			X		Horz. Pckt.			<i>5 3/8 X 11 1/8</i>	<i>1</i>
Vert. Pckt.			X		Horz. Pckt.			X	
Pocket			X		Pocket			X	
Label Holder			X		Card Hlder			X	
Material			X		Material			X	
Material			X		Material			X	
Material			X		Material			X	
F.C. Board			<i>11 1/32 X 10 15/32</i>	<i>1</i>	B.C. Board			<i>11 1/32 X 10 15/32</i>	<i>1</i>
B.C. Board			X		B.B. Board			<i>11 1/32 X 1 29/32</i>	<i>1</i>
Center Board			X		Board			X	
Board			X		Strip			X	
Cover Pad			X		Strip			X	
					B.B. Pad			X	

Stock

Product Code

Style Case

VRB W/FLAP

Sheet Size 11 x 9 Cap. 1

Die No. 4178

Order No. 962228

Plate

Customer MEETING PLANNERS INT.

Metal
Total Vinyl
Quantity
Date
Type Corners
Radius
Completed

	Gauge	Thick
Tear Seal	.016	32
Bar Seal	1	32
Bar Seal	178	3/16"

	No. of Feet
Tear Seal	
Bar Seal	
Bar Seal	

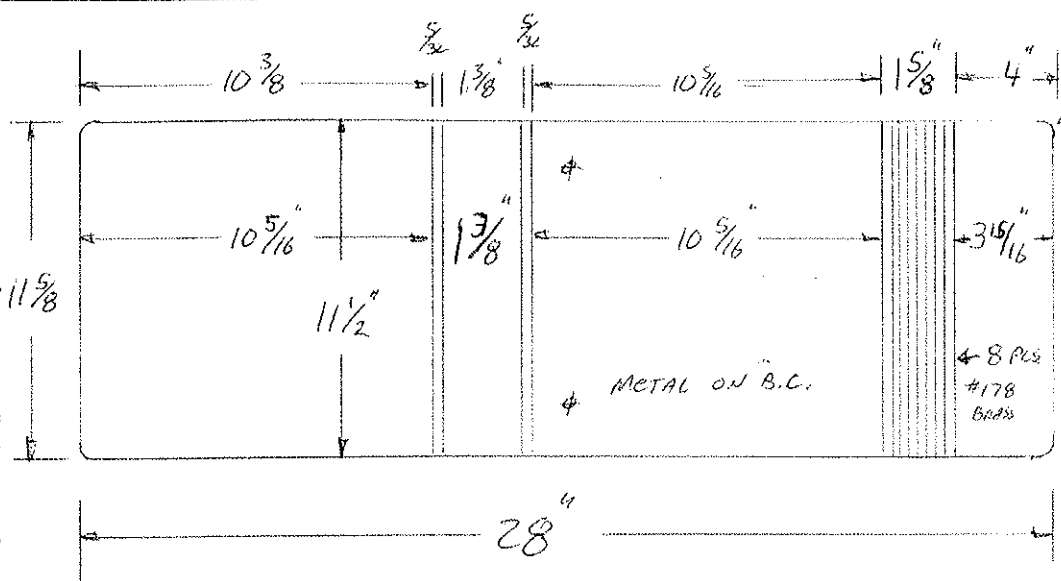

Code		Cutting Specs		Code		Cutting Specs			
		Ga.	PCS	Size	Out	Ga.	Pcs.	Size	Out
Cover Mat.	12 5/16" X 29"	15	1			Lining Mat.		12 5/16" X 29"	15 1
Cover Mat.	X					Lining Mat.		X	
Vert. Pckt.	X					Horz. Pckt.		X	
Vert. Pckt.	X					Horz. Pckt.		5 7/8" X 22 7/8"	15 1
Pocket	X					Pocket		X	
Label Holder	X					Card Holder		2 7/8" X 4 1/2"	8 1
Material	X					Material		X	
Material	X					Material		X	
Material	X					Material		X	
F.C. Board	11 1/32" X 10 7/32"	120	1			B.C. Board		11 1/32" X 1 9/32"	120 1
B.C. Board	11 1/32" X 10 7/32"	120	1			B.B. Board		X	
Center Board	X					Board	FLAP	11 1/32" X 3 27/32"	120 1
Board ^{Fluted Board} _{Die cut}	12 X 3 1/2 X 30					Strip		X	
Cover Pad	X					Strip		X	
FC Board	11 7/16" X 10 1/4"	100	1			B.B. Board		11 7/16" X 1 9/32"	100 1
BC Board	11 7/16" X 10 1/4"	100	1			Flap		11 7/16" X 3 7/8"	100 1

Product Code

Style Case VRB W/ FLAP

Sheet Size 11 x 9 Cap. 1/2 Die No. 4191 Order No. 962204 Plate

Customer PALM BEACH COUNTY SCHOOL SYSTEM

Metal
Total Vinyl
Quantity <u>250</u>
Date <u>4-26-89</u>
Type Corners <u>RNO</u>
Radius <u>3/8"</u>
Completed

	Gauge	Thick
Tear Seal	<u>.016</u>	<u>3/64"</u>
Bar Seal	<u>7 X 178</u>	<u>3/32"</u>
Bar Seal		

	No. of Feet
Tear Seal	
Bar Seal	
Bar Seal	

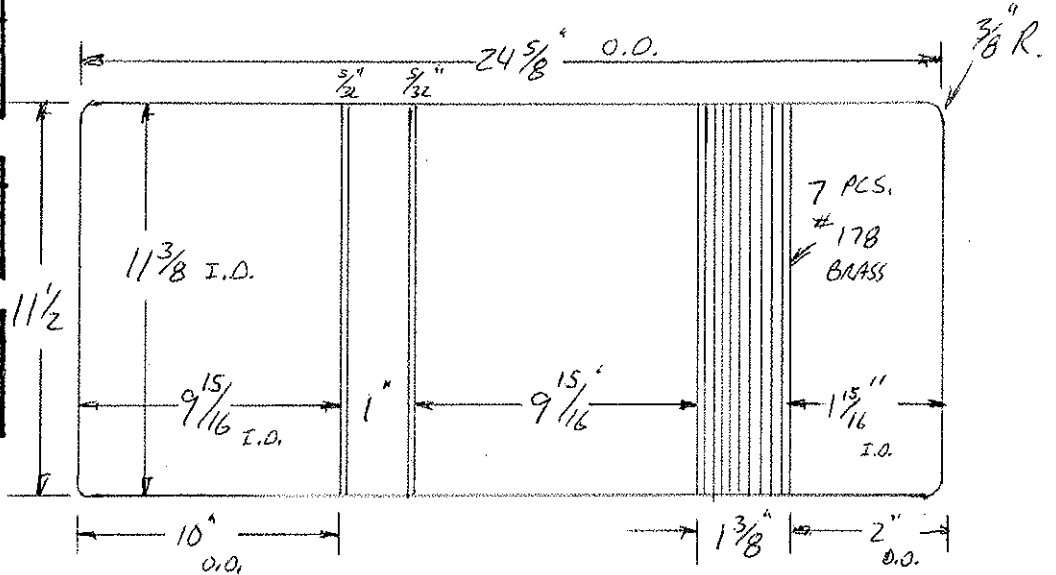

Code	Description	Ga.	#	Cutting Specs		Code	Description	Ga.	#	Cutting Specs	
				Size	Out					Size	Out
	Cover Mat.			12 1/4	25 1/2		Lining Mat.			12 1/4	25 1/2
	Cover Mat			12 5/8	25 7/8		Lining Mat.			X	
	Vert. Pckt.			X			Horz. Pckt.			5 3/8	21 3/4
	Vert. Pckt.			X			Horz. Pckt.			X	
	Pocket			X			Pocket			X	
	Label Hoker			X			Card Hlder			X	
	Material			X			Material			X	
	Material			X			Material			X	
	Material			X			Material			X	
	F.C. Board			11 1/4	9 27/32	100	1	B.C. Board		X	
	B.C. Board			11 1/4	9 27/32	100	1	B.B. Board		11 1/4	9 27/32
	Center Board			X			Board			FLAP	11 1/4
	Board			X			Strip			X	
	Cover Pad			X			Strip			X	
							B.B. Pad			X	

Product Code

Style Case *VRB W/FLAP*

Sheet Size *11 x 9* Cap. *1 1/2* Die No. *4474-A* Order No. *965995* Plate

Customer

MEETING PLANNERS INT'L.

Metal
Total Vinyl
Quantity <i>2500</i>
Date <i>7-13-90</i>
Type Corners
Radius <i>3/8"</i>
Completed

	Gauge	Thick
Tear Seal	<i>.014</i>	<i>1/16</i>
Bar Seal	<i>#254</i>	<i>3/32"</i>
Bar Seal		

	No. of Feet
Tear Seal	
Bar Seal	
Bar Seal	

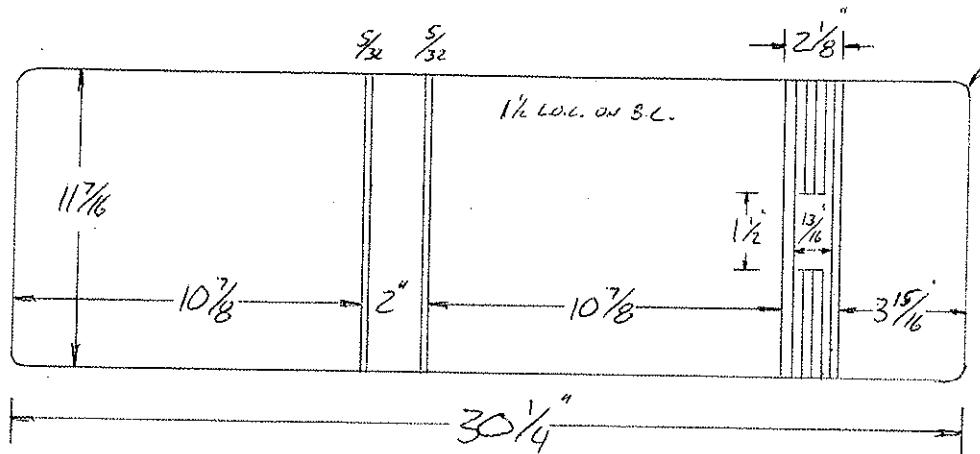

Size - B. Spec
Green - KPV Calc only
REQUIRES CUT DIE #4474-B

Code		Cutting Specs				Code		Cutting Specs			
		Ga.	PCS	Size	Out			Ga.	Pcs.	Size	Out
Cover Mat.	<i>12 1/4 x 31 1/4</i>	<i>15</i>	<i>1</i>			Lining Mat.	<i>DIE CUT</i>	<i>12 1/4 x 31 1/4</i>	<i>15</i>	<i>1</i>	
Cover Mat	X					Lining Mat.		X			
Vert. Pckt.	X					Horz. Pckt.	<i>5 3/8 x 11 3/8</i>	<i>13</i>	<i>1</i>		
Vert. Pckt.	X					Horz. Pckt.	X				
Pocket	X					Pocket	<i>Appl. 2 x 3</i>				
Label Holder	X					Card Holder	<i>2 7/8 x 4 1/2</i>				
Material	X					Material	X				
Material	X					Material	X				
Material	X					Material	X				
F.C. Board	<i>11 1/32 x 10 25/32</i>	<i>100</i>	<i>1</i>			B.C. Board	X				
B.C. Board	<i>11 1/32 x 10 25/32</i>	<i>100</i>	<i>1</i>			B.B. Board	<i>11 1/32 x 1 29/32</i>	<i>100</i>	<i>1</i>		
Center Board	X					Board	<i>FLAP 11 1/32 x 3 27/32</i>	<i>100</i>	<i>1</i>		
Board	X					Strip	X				
Cover Pad	X					Strip	X				
						B.B. Pad	X				

Stock

Product Code

Style Case VRB W/FLAP.

Sheet Size 11 x 9

Cap. 1 1/2

Die No. 4541

Order No. 966636

Plate

Customer

SCHOOL BOARD OF PALM BEACH CO.

Metal
Total Vinyl
Quantity <u>250</u>
Date <u>9-18-90</u>
Type Corners
Radius <u>3/8" R</u>
Completed

	Gauge	Thick
Tear Seal	<u>.014</u>	<u>1/16"</u>
Bar Seal	<u>.2253</u>	<u>5/32"</u>
Bar Seal	<u>.4178</u>	<u>3/16"</u>

	No. of Feet
Tear Seal	
Bar Seal	
Bar Seal	

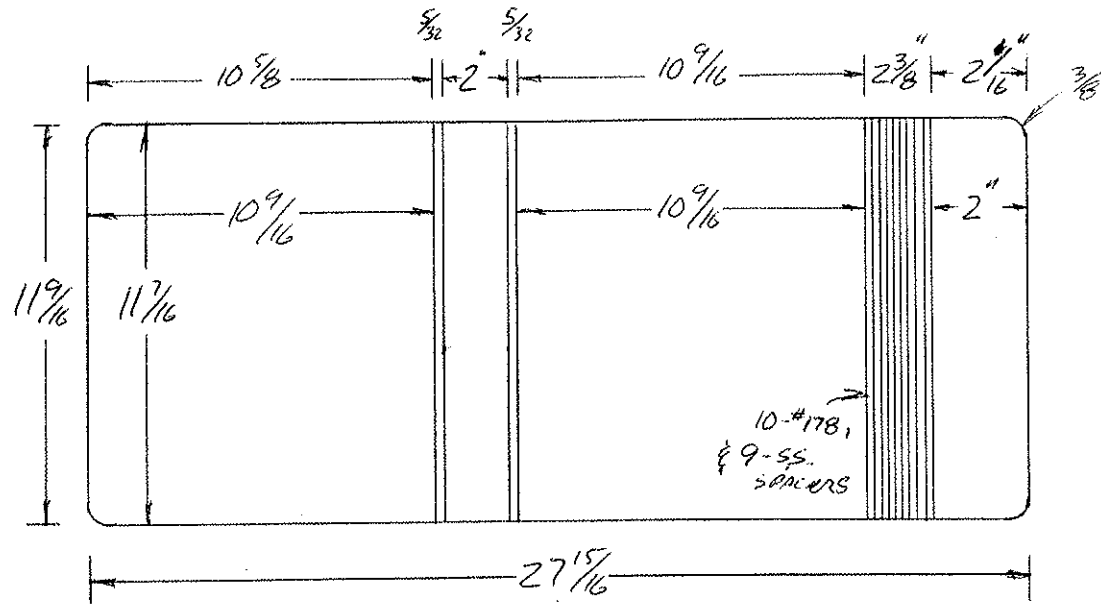

Orig. B.P. ✓

Check - *(Signature)*

Code	Ga.	PCS	Cutting Specs		Code	Ga.	Pcs.	Cutting Specs	
			Size	Out				Size	Out
Cover Mat.		<u>12 1/4 x 29</u>	<u>14</u>	<u>1</u>	Lining Mat.		<u>12 1/4 x 29</u>	<u>14</u>	<u>1</u>
Cover Mat.		X			Lining Mat.		X		
Vert. Pckt.		X			Horz. Pckt.		X		
Vert. Pckt.		<u>GLASS X CLEAR</u>			Horz. Pckt.		X		
Pocket	<u>5"</u>	<u>5 7/8 x 24"</u>	<u>8</u>	<u>1</u>	Pocket		X		
Label Holder		X			Card Holder		X		
Material		X			Material		X		
Material		X			Material		X		
Material		X			Material	<u>STOCK-SIZE</u>	X		
F.C. Board		<u>11 1/32 x 10 15/32</u>	<u>100</u>	<u>1</u>	B.B. Board	<u>FLAP</u>	<u>11 1/32 x 1 29/32</u>	<u>100</u>	<u>1</u>
B.C. Board		<u>11 1/32 x 10 15/32</u>	<u>100</u>	<u>1</u>	B.B. Board		<u>11 1/32 x 1 29/32</u>	<u>100</u>	<u>1</u>
Center Board		X			Board		X		
Board		X			Strip		X		
Cover Pad		X			Strip		X		
		<u>Padded Bd. Die # 4541-A</u>			B.B. Pad		X		
		<u>14 3/4 - 24 1/4</u>							

Product Code

Style Case VRB W/FLAP

Sheet Size 11 1/2 X 8 3/4 Cap. 1"

Die No. 4646

Order No. 967620

Plate

Customer

TOP FLIGHT

Metal
Total Vinyl
Quantity <u>500</u>
Date <u>1-28-91</u>
Type Corners
Radius <u>7/8"</u>
Completed

	Gauge	Thick
Tear Seal	<u>.012</u>	<u>1/16"</u>
Bar Seal	<u>#48-3</u>	<u>1/8"</u>
Bar Seal	<u>#253</u>	

	No. of Feet
Tear Seal	
Bar Seal	
Bar Seal	

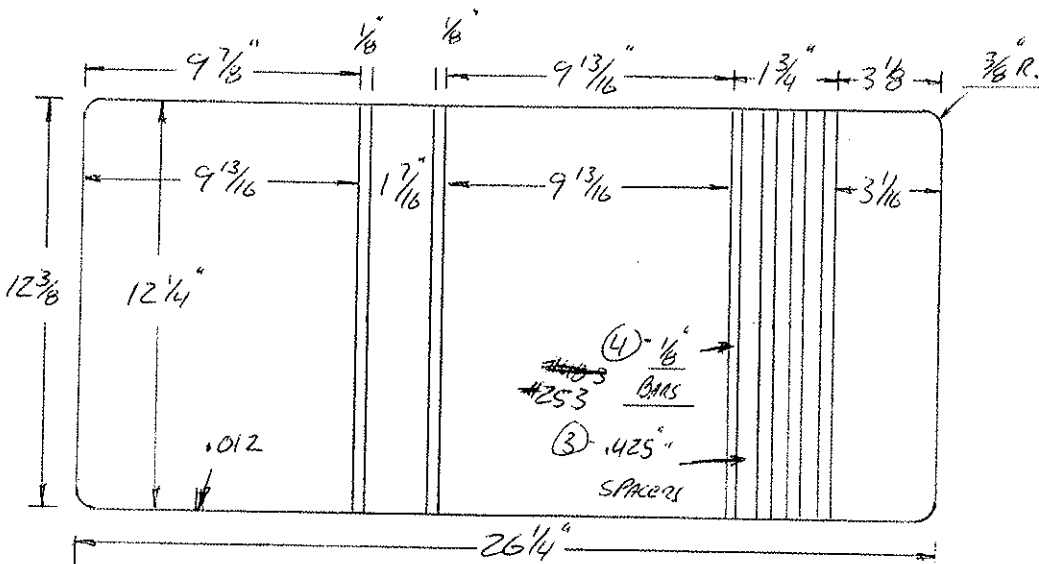

SIZE - B. PAGE
CHECK YAV

Code		Ga.		# PCS		Cutting Specs		Code		Ga.		# Pcs.		Cutting Specs	
						Size	Out					Size	Out		
Cover Mat.		13 1/4	X	27 1/4	8	1		Lining Mat.		13 1/4	X	27 1/4	15	1	
Cover Mat.		X						Lining Mat.		X					
Vert. Pckt.		X						Horz. Pckt.		X					
Vert. Pckt.		X						Horz. Pckt.		5 3/8	X	21 3/4	8	1	
Pocket		X						Pocket		X					
Label Holder		X						Card Holder		X					
Material		X						Material		X					
Material		X						Material		X					
Material		X						Material		X					
F.C. Board	ROUND	12 5/32	X	9 23/32	100	1		B.C. Board		X					
B.C. Board	SQUARE	12 5/32	X	9 23/32	100	1		B.B. Board		12 5/32	X	1 1/32	100	1	
Center Board		X						Board	ROUND CORNERS	12 5/32	X	2 3/32	100	1	
Board		X						Strip		X					
Cover Pad		X						Strip		X					
								B.B. Pad		X					

DIE #	4731-R	METAL		RADIUS	3/8
ORDER #		CUSTOMER	DONCASTER	TEAR SEAL	.014
SHEET SIZE	11 X 9	STYLE CASE	VINYL RING BINDER W/FLAP	BAR SEAL	253 - 17
CAP.	1 1/2"	DUE DATE		COMPLETED	
LOCATION	C-13-9	QUANTITY		DATE	6-7-95

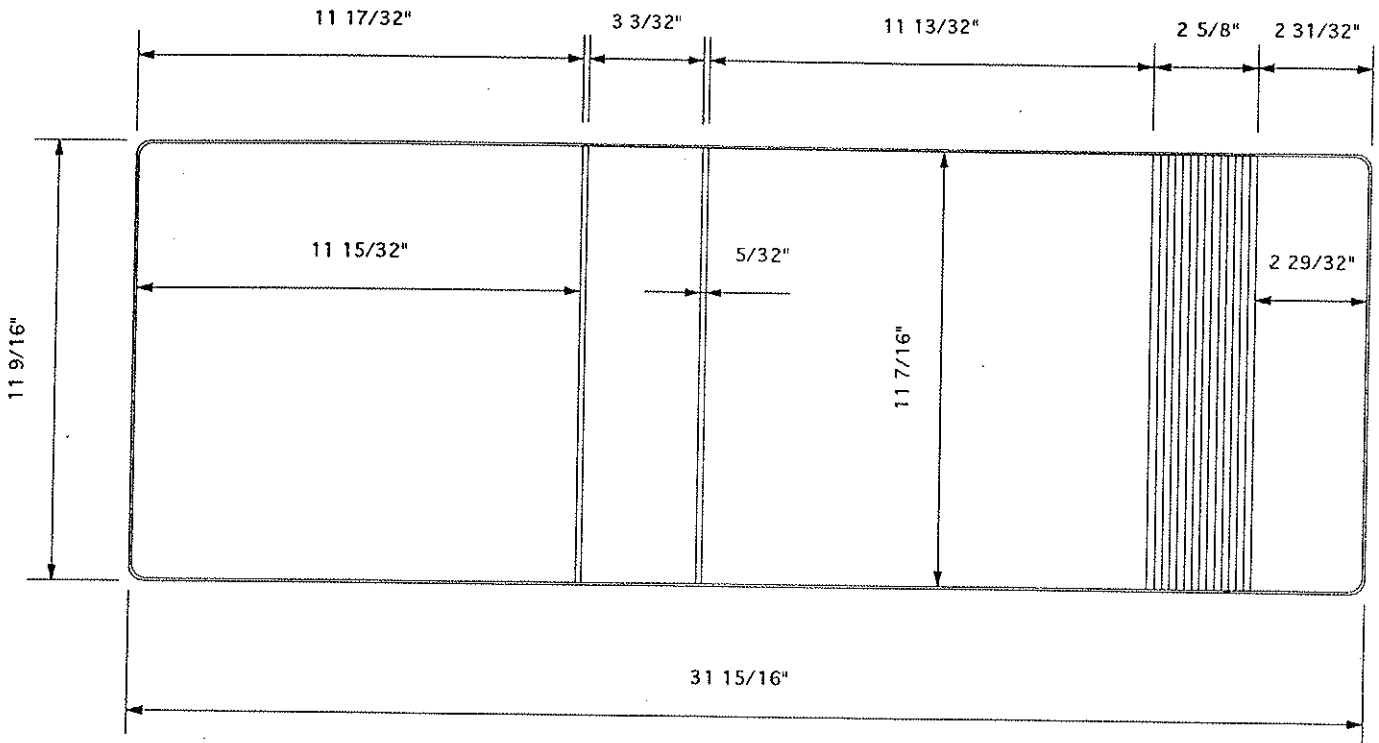

MATERIAL SPECS		GAUGE PCS.		MATERIAL SPECS		GAUGE PCS.	
COVER MAT.	12 1/4 X 33		1	LINING MAT.	12 1/4 X 33		
COVER MAT.	12 9/16 X 33 (PADDED)		1	LINING MAT.			
DIE CUT				HORZ. PKT.	5 3/8 X 27 1/8		
COL	11 11/16 X 10		1	VERT. PKT.			
LABEL HOLDER				DIE CUT			
GUSSET				REINF.			

BOARD SPECS		GAUGE PCS.		BOARD SPECS		GAUGE PCS.	
F.C. BOARD	11 3/8 x 11 13/32		2	F.C. BOARD			
B.B. BOARD	11 3/8 x 3		1	B.B. BOARD			
B.C. BOARD	11 3/8 x 2 13/16		1	B.C. BOARD	Padded		
B.U. STRIP				DIE CUT	12 3/8 x 31	DIE 4731-B	120 1
DIE CUT				DIE CUT	all panels + Spines Padded		

Flap

Product Code

Style Case VR3 w/FLAP

Sheet Size 9 X 5 3/4 Cap. 3/4

Die No. 4987

Order No. 971315

Plate D-4-1

Customer

IDEAS UNLIMITED

2-14

Metal
Total Vinyl
Quantity <u>1</u>
Date <u>2-7-92</u>
Type Corners
Radius <u>3/8"</u>
Completed

	Gauge	Thick
Tear Seal	<u>.014</u>	<u>1/16</u>
Bar Seal	<u>48-3</u>	<u>1/8</u>
Bar Seal		

	No. of Feet
Tear Seal	
Bar Seal	
Bar Seal	

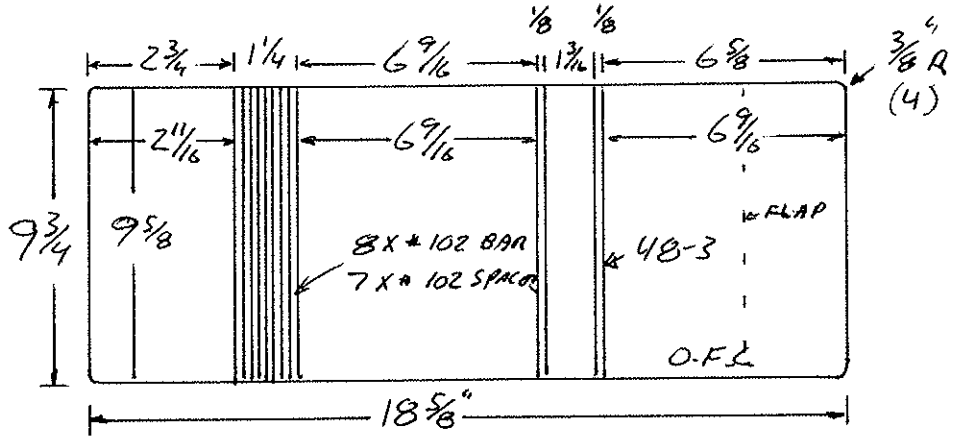

OUTSIDE VIEW.

DWG. - B. Pace
 Check. *(Signature)*

Code	Ga.	PCS	Cutting Specs		Code	Ga.	Pcs.	Cutting Specs	
			Size	Out				Size	Out
Cover Mat.			<u>10 3/8</u>	<u>19 3/8</u>	Lining Mat.			<u>10 3/8</u>	<u>19 3/8</u>
Cover Mat.			X		Lining Mat.			X	
Vert. Pckt.			X		Horz. Pckt. <u>PROSTO</u>			<u>4 3/8</u>	<u>19 3/8</u>
Vert. Pckt.			X		Horz. Pckt. <u>" "</u>			<u>6 3/8</u>	<u>19 3/8</u>
Pocket			X		Pocket			X	
Label Holder			X		Card Holder			X	
Material			X		Material			X	
Material			X		Material			X	
Material			X		Material			X	
F.C. Board			<u>100</u>	<u>1</u>	B.C. Board			X	
B.G. Board			<u>100</u>	<u>1</u>	B.B. Board			<u>9 9/16</u>	<u>1 3/32</u>
Center Board			X		Board			<u>9 9/16</u>	<u>2 5/8</u>
Board			X		Strip			X	
Cover Pad			X		Strip			X	
					B.B. Pad			X	

Product Code

Style Case VRB W/FLAP.

Sheet Size *11 3/4 x 9

Cap. 1'

Die No. 5107B

Order No. 972769

Plate D-8-8

STREET PRINTING

7-18

Customer	
Material	
Material Vinyl	
Quantity	250
Part No.	6-3092
Top Corners	
Radius	3/8"
Completed	

	Gauge	Thick
Bar Seal	.014	1/16
Tr Seal	#254	5/32
Tr Seal	#178	3/16 X 8

	No. of Feet
Bar Seal	
Tr Seal	
Tr Seal	

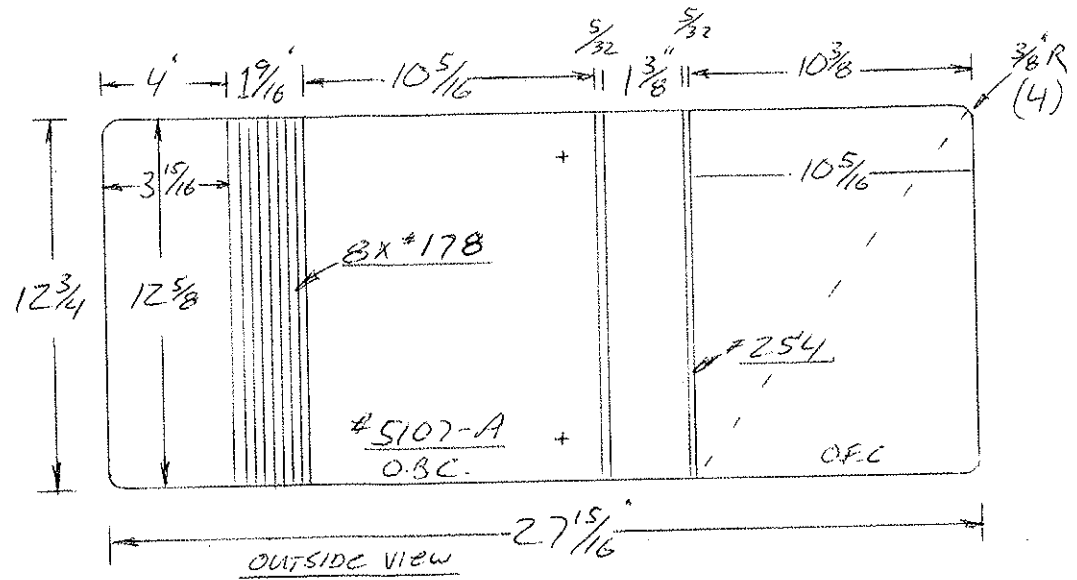

Dwg. BRICE
 Check. AM

SEE CUTTING DIE # 5107-B

*USE LOADING TRAY # 5106

Code	Ga.	#	Cutting Specs.		Code	Ga.	#	Cutting Specs.	
			Size	Out				Size	Out
Cover Mat.			13 1/2	29	Lining Mat.			13 1/2	29
Cover Mat.			X		Lining Mat.			X	
Vert. Pckt.			X		Horz. Pckt. PICK-			1 1/2	11"
Vert. Pckt.			X		Horz. Pckt. -UP			1 7/8	11"
Pocket	0179		14	1/2	Pocket			X	
Label Holder	die # 5106		8	2	Card Holder			X	
Material			X		Material			X	
Material			X		Material			X	
Material			X		Material			X	
F.C. Board			X		B.C. Board			X	
B.C. Board			X		B.B. Board			X	
Center Board	ADDED		X		Board			X	
Board	die - cut		100	1	Strip			X	
Cover Pad			X		Strip			X	
					B.B. Pad			X	

Product Code

Style Case *Vinyl Slder*

Sheet Size *11 x 8 1/2*

Cap.

Die No. *5289*

Order No. *974523*

Plate

Customer

Colad

017-1

Metal
Total Vinyl
Quantity <i>4</i>
Date <i>2-22-75</i>
Type Corners <i>39</i>
Radius <i>0</i>
Completed

All Bars $\frac{1}{8}$ HFT #46

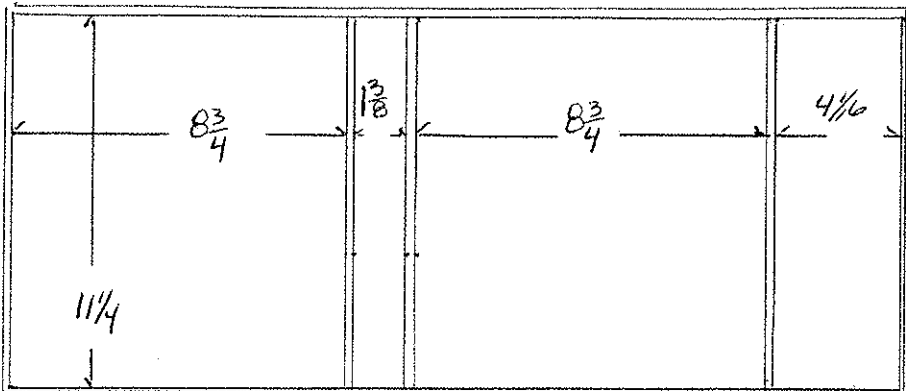

	Gauge	Thick
Tear Seal		
Bar Seal		
Bar Seal		

	No. of Feet
Tear Seal	
Bar Seal	
Bar Seal	

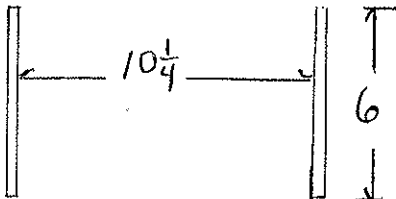

fim

				Cutting Specs								Cutting Specs				
Code		Ga.	# PCS	Size	Out	Code		Ga.	# Pcs.	Size	Out			Cutting Specs		
Cover Mat.				<i>11 7/16 X 24 3/16</i>			Lining Mat.			<i>12 1/8 X 24 3/16</i>						
Cover Mat.				X			Lining Mat.			X						
Vert. Pckt.				X			Horz. Pckt.			<i>3 1/8 X 19 1/16</i>						
Vert. Pckt.				X			Horz. Pckt.			<i>3 3/8 X 24 3/16</i>						
Pocket				X			Pocket			X						
Label Holder				X			Card Hlder			X						
Material				X			Material			X						
Material				X			Material			X						
Material				X			Material			X						
F.C. Board				X			B.C. Board			X						
B.C. Board				X			B.B. Board			X						
Center Board				X			Board			X						
Board				X			Strip			X						
Cover Pad				X			Strip			X						
							B.B. Pad			X						

Product Code

Stock Style Case URB w Flap

Sheet Size 11 X 8 1/2 Cap. 3/4 Die No. 5330 Order No. 975146 Plate E1-3

Customer ISIS Health Systems

Metal
Total Vinyl
Quantity 750
Date 5-19-93
Type Corners RND
Radius 3/8
Completed

	Gauge	Thick
Tear Seal	.014	1/16
Bar Seal	484	5/32
Bar Seal		

	No. of Feet
Tear Seal	
Bar Seal	
Bar Seal	

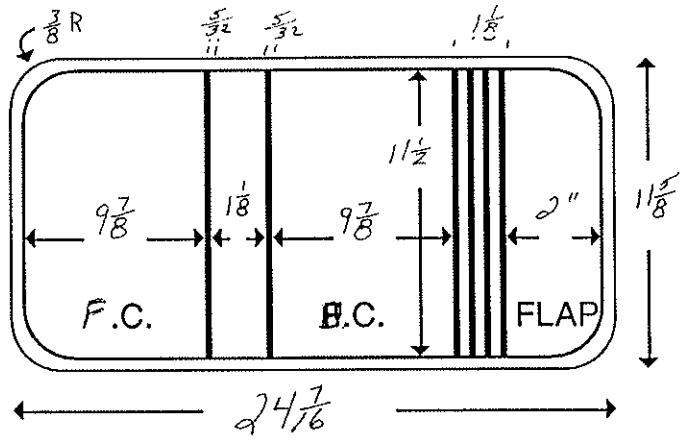

Sim

Code	Ga.	# PCS	Cutting Specs		Code	Ga.	# Pcs.	Cutting Specs	
			Size	Out				Size	Out
Over Mat.		1	12 3/8	25 3/16	Lining Mat.		1	12 3/8	25 3/16
Over Mat				X	Lining Mat.				X
Vert. Pckt.				X	Horz. Pckt.				X
Vert. Pckt.				X	Horz. Pckt.				X
Pocket				X	Pocket				X
Label Holder				X	Card Holder				X
Material				X	Material				X
Material				X	Material				X
Material				X	Material				X
F.C. Board		100	11 7/16	9 13/16	B.C. Board				X
F.C. Board		100	11 7/16	9 13/16	B.B. Board				X
Center Board		100	11 7/16	1 3/32	Board				X
Board		100	11 7/16	1 15/16	Strip				X
Over Pad				X	Strip				X
					B.B. Pad				X

Product Code

Style Case Folder w/Flap

Sheet Size 8 1/2 x 5 1/2 Cap.

Die No. 5382

Order No. 975658

Plate E4-4

BMW Manufacturing

Customer	
Metal	
Total Vinyl	
Quantity	2500
Date	7-23-93
Type Corners	Sq
Radius	0
Completed	

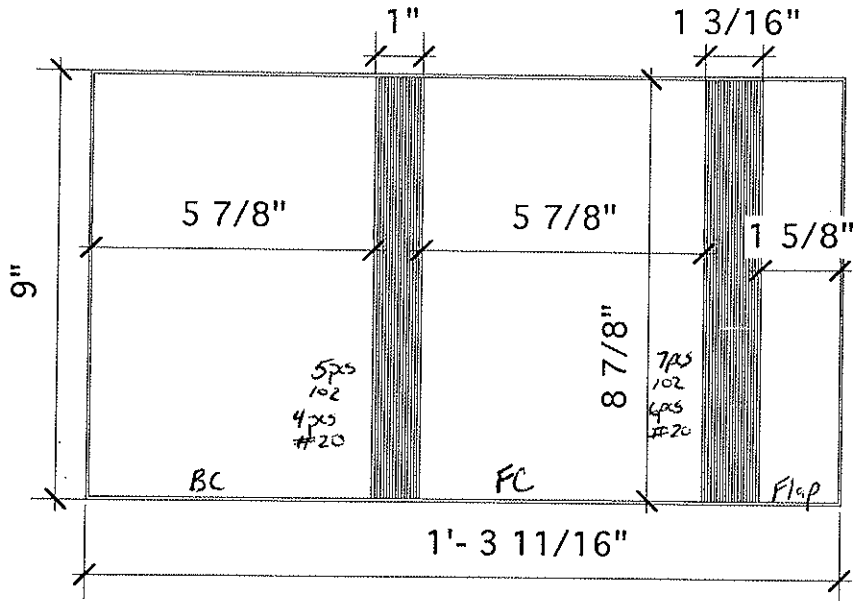

	Gauge	Thick
Tear Seal	.012	1/16
Bar Seal		
Bar Seal		

	No. of Feet
Tear Seal	
Bar Seal	
Bar Seal	

Code	Ga.	Pcs	Cutting Specs		Code	Ga.	Pcs	Cutting Specs	
			Size	Out				Size	Out
Cover Mat.			9 3/4 X	16 7/16	Lining Mat.			9 3/4 X	16 7/16
Cover Mat			9 7/8 X	6 7/8	Lining Mat.				
Vert. Pckt.				X	Horz. Pckt.				X
Vert. Pckt.				X	Horz. Pckt.				X
Pocket				X	Pocket				X
Label Holder	Husset		8 X	12 7/16	Card Holder				X
Material				X	Material				X
Material				X	Material				X
Material				X	Material				X
F.C. Board			8 13/16 X	5 13/16	B.C. Board				X
B.C. Board			8 13/16 X	5 13/16	B.B. Board				X
Center Board			8 13/16 X	1 9/16	Board				X
Board				X	Strip				X
Cover Pad				X	Strip				X
					B.B. Pad				X

DIE #	7043-A	METAL	RR W/BOOSTER	RADIUS	3/8"
ORDER #	397440	CUSTOMER	APPLIED PRINTING	TEAR SEAL	.010
SHEET SIZE	11 X 5 1/2	STYLE CASE	VINYL BINDER W/FLAP	BAR SEAL	253
CAP.	3/4"	DUE DATE	1-12-01	COMPLETED	
LOCATION		QUANTITY	100	DATE	1-4-01

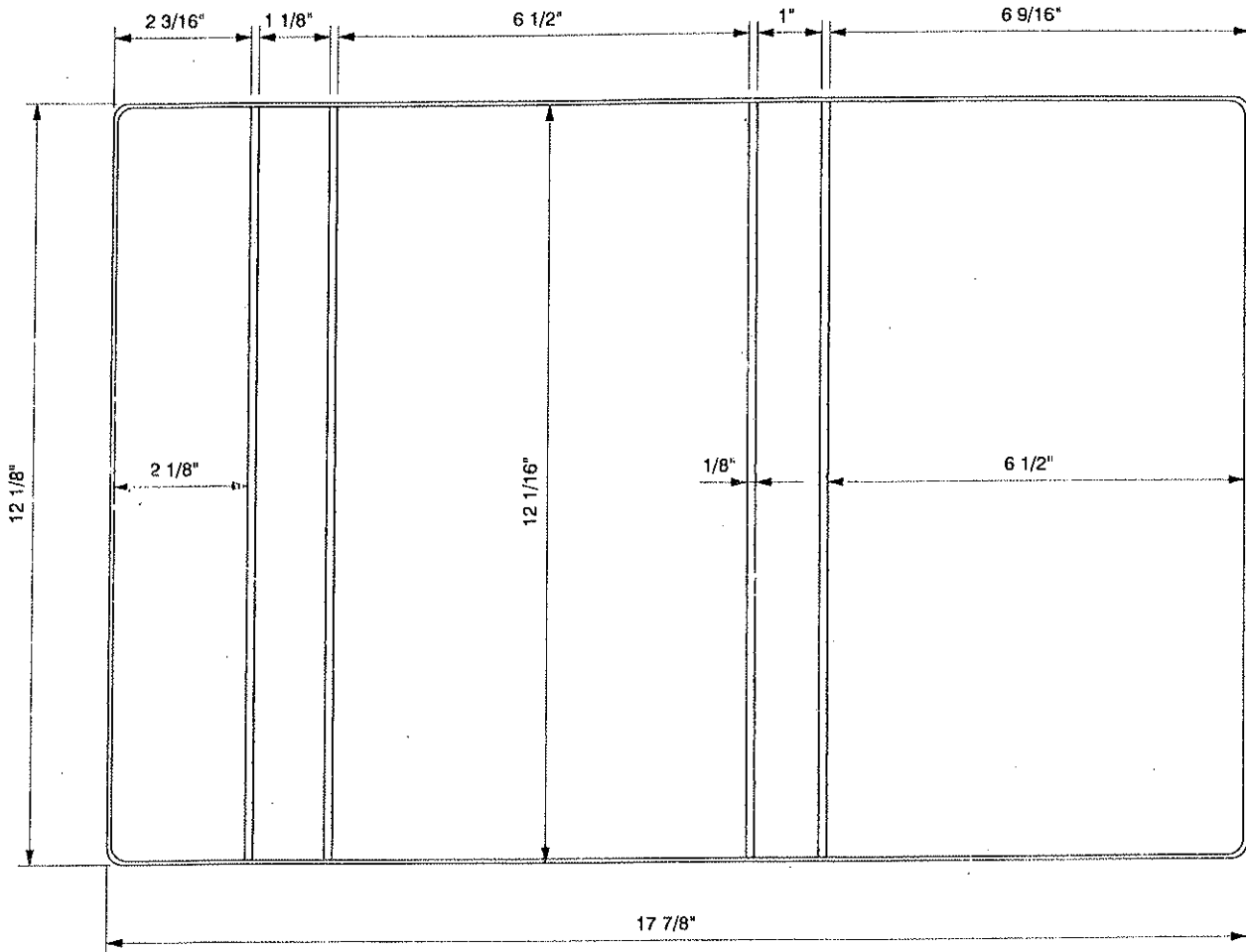

MATERIAL SPECS		GAUGE	PCS.	MATERIAL SPECS		GAUGE	PCS.
COVER MAT.	12 7/8 X 18 5/8		1	LINING MAT.	12 7/8 X 18 5/8		1
COVER MAT.				LINING MAT.			
DIE CUT				HORZ. PKT.	8 5/8 X 5 5/8		1
COL				VERT. PKT.			
LABEL HOLDER				DIE CUT			
GUSSET				REINF.			

BOARD SPECS		5/16" R. CORNERS	GAUGE	PCS.	BOARD SPECS		5/16" R. CORNERS	GAUGE	PCS.
F.C. BOARD					F.C. BOARD	Padded Bd. Die # 7043 B			
B.B. BOARD					B.B. BOARD	18 1/2 x 14 3/8			
B.C. BOARD					B.C. BOARD				
FLAP BD.					DIE CUT				
BOARD					DIE CUT				

DIE #	6005	METAL	9 1/2" RR NB	RADIUS	1/4"
ORDER #	983853	CUSTOMER	OLAN MILLS	TEAR SEAL	.014
SHEET SIZE	10 X 8 1/2	STYLE CASE	VINYL RING BINDER W/FLAP	BAR SEAL	253
CAP.	1"	DUE DATE	2-20-96	COMPLETED	
LOCATION	F-1-8	QUANTITY	1	DATE	2-15-96

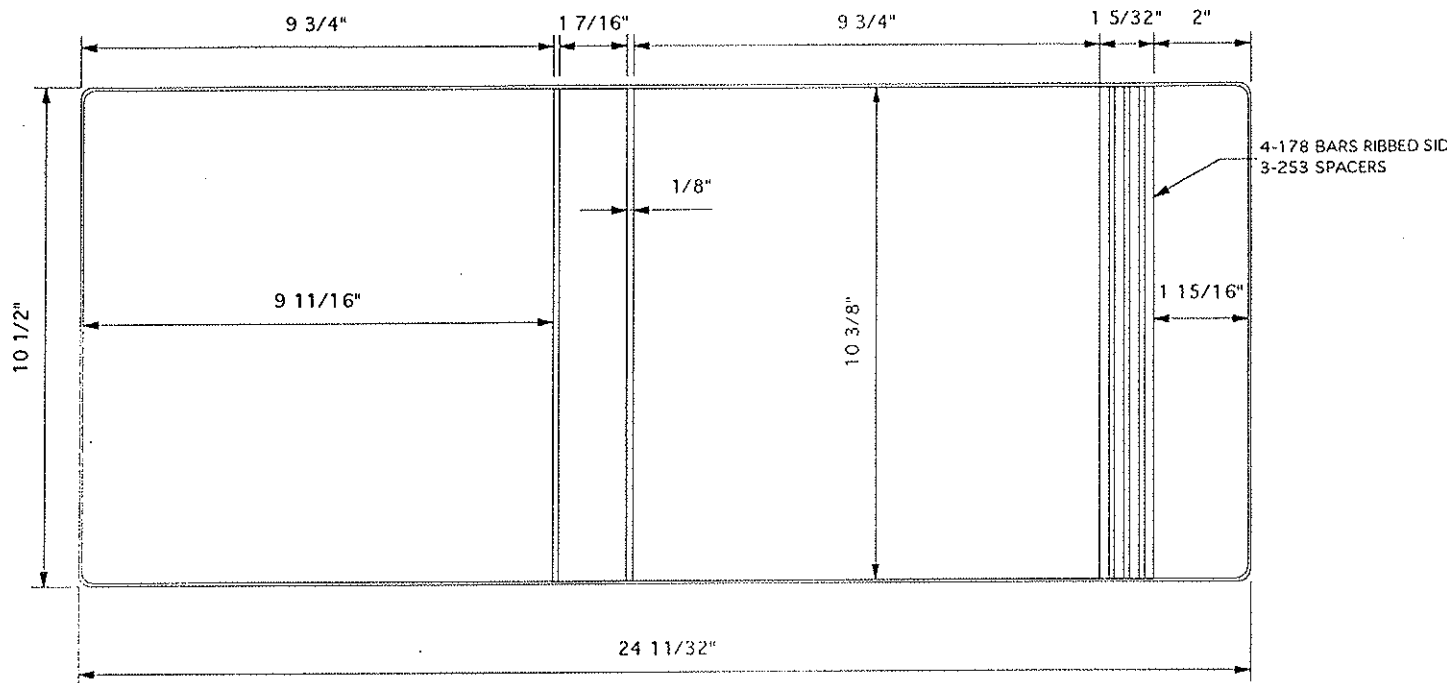

MATERIAL SPECS		GAUGE		PCS.		MATERIAL SPECS		GAUGE	
COVER MAT.	11 1/4 X 25 1/8			LINING MAT.	11 1/4 X 25 1/8				
COVER MAT.				LINING MAT.					
DIE CUT				HORZ. PKT.					
COL				VERT. PKT.					
LABEL HOLDER				DIE CUT					
GUSSET				REINF.					

BOARD SPECS		GAUGE		PCS.		BOARD SPECS		GAUGE	
F.C. BOARD	10 5/16 X 9 5/8	48	1	F.C. BOARD					
B.B. BOARD	10 5/16 X 1 11/32	100	1	B.B. BOARD					
B.C. BOARD	10 5/16 X 9 11/16	48	1	B.C. BOARD					
FLAP	10 5/16 X 1 27/32	48	1	DIE CUT					
DIE CUT				DIE CUT					

Stack

DIE #	6012	METAL	2" HOC	RADIUS	3/8
ORDER #	984009	CUSTOMER	BALLERINI MARKETING	TEAR SEAL	.014
SHEET SIZE	11 X 9	STYLE CASE	VRB W/ FLAP	BAR SEAL	178-253
CAP.	2"	DUE DATE	3-22-96	COMPLETED	
LOCATION	L-5-9	QUANTITY	2500	DATE	3-4-96

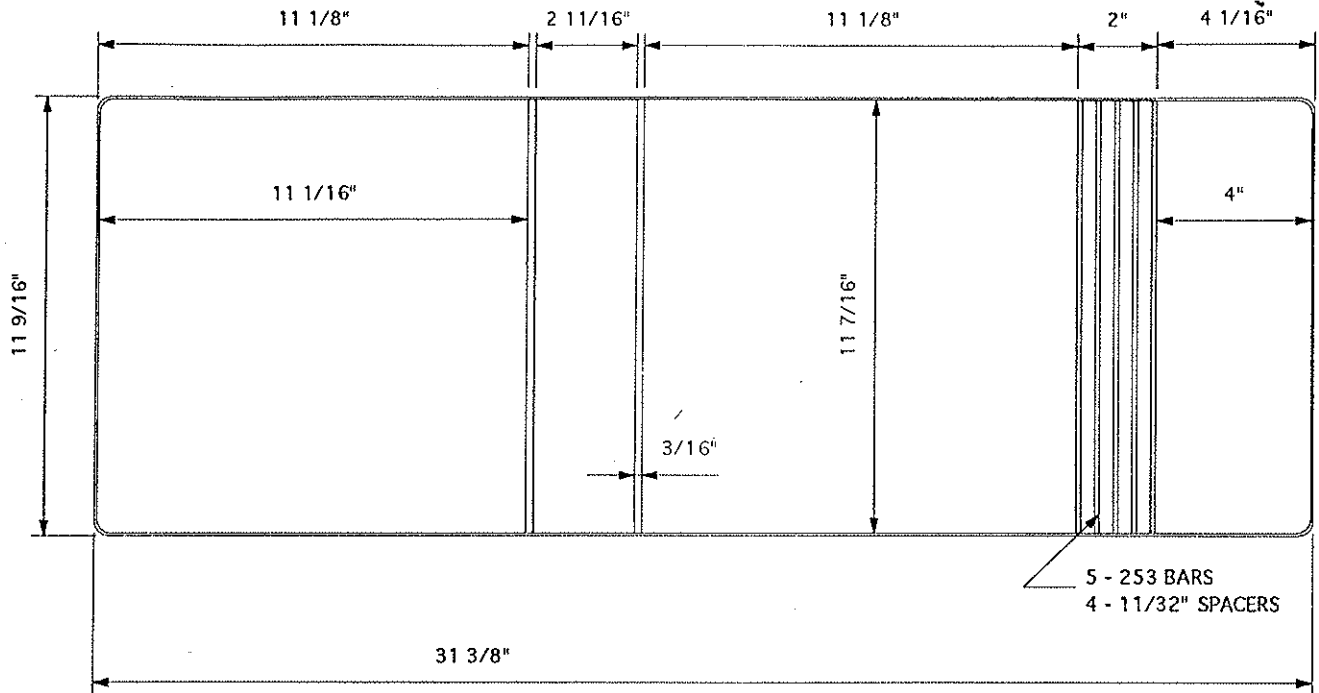

MATERIAL SPECS		GAUGE		MATERIAL SPECS		GAUGE	
COVER MAT.	12 5/16 X 32 1/8		1	LINING MAT.	12 5/16 X 32 1/8		1
COVER MAT.				LINING MAT.			
DIE CUT				HORZ. PKT.	4 7/8 X 11 11/16		
COL				VERT. PKT.			
LABEL HOLDER				DIE CUT			
GUSSET				REINF.			

BOARD SPECS		GAUGE		BOARD SPECS		GAUGE	
F.C. BOARD	11 11/32 X 10 31/32	120	1	F.C. BOARD			
B.B. BOARD	11 11/32 X 2 19/32	120	1	B.B. BOARD			
B.C. BOARD	11 11/32 X 10 31/32	120	1	B.C. BOARD			
FLAP BD.	11 11/32 X 3 29/32	120	1	DIE CUT			
DIE CUT				DIE CUT			

2-up Job - Die # 5514

DIE #	6136	METAL		RADIUS	3/8"
ORDER #		CUSTOMER	CAROLINA PAD AND PAPER	TEAR SEAL	.008
SHEET SIZE	11 X 9	STYLE CASE	1 UP VRB WITH FLAP	BAR SEAL	253
CAP.	1"	DUE DATE		COMPLETED	
LOCATION		QUANTITY		DATE	4-11-96

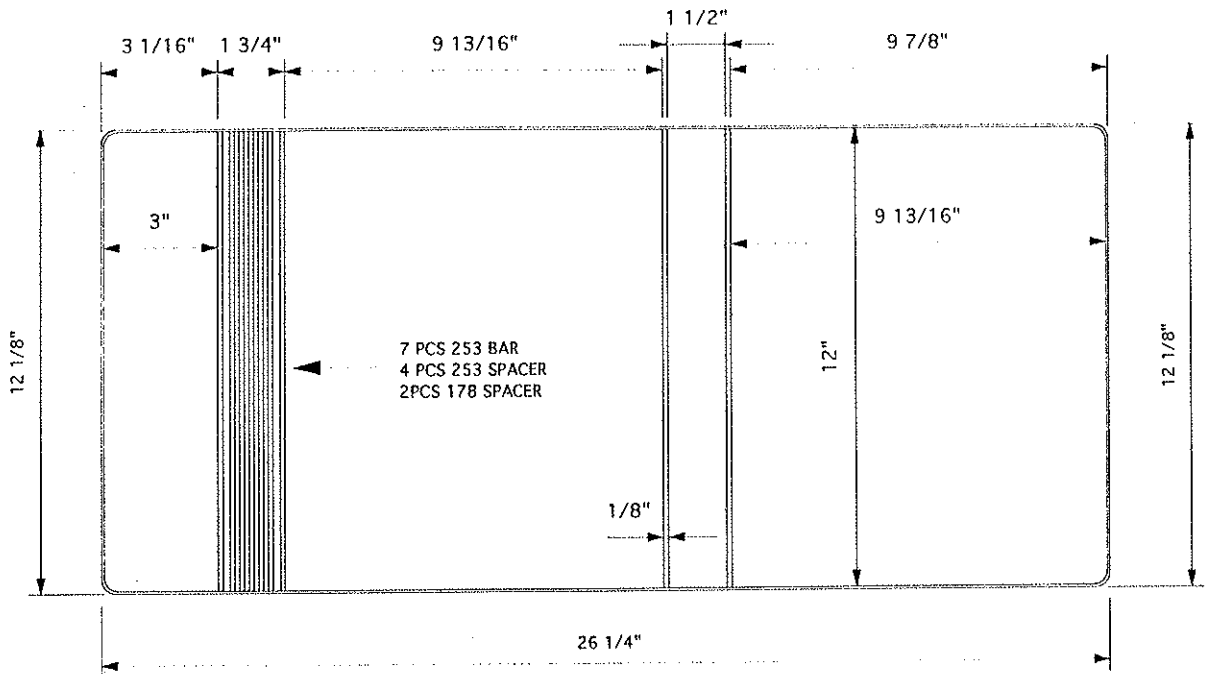

MATERIAL SPECS		GAUGE		PCS.		MATERIAL SPECS		GAUGE		PCS.	
COVER MAT.	12 7/8 X 27			1		LINING MAT.	12 7/8 X 27			1	
PICTORIAL	12 7/8 X 27			1		LINING MAT.					
LABEL HOLDER						HORZ. PKT.	5 3/8 X 27				
COL						HORZ. PKT.					
EX COL NO TRIM						ONE SIDED					
EX COL						ONE SIDED					

NORMAL 1/16" TOL			PCS.			EXPANDED MATERIAL BOARD TOL. (3/32")			PCS.		
F.C. BOARD	11 15/16 X 9 3/4	1	F.C. BOARD	11 29/32 X 9 23/32	1						
B.B. BOARD	11 15/16 X 1 13/32	1	B.B. BOARD	11 29/32 X 1 13/32	1						
B.C. BOARD	11 15/16 X 9 3/4	1	B.C. BOARD	11 29/32 X 9 23/32	1						
FLAP BD.	11 15/16 X 2 29/32	1	DIE CUT	11 29/32 X 2 29/32	1						

DIE #	6317	METAL	NB RR	RADIUS	3/8"
ORDER #	988026	CUSTOMER	COMPAQ	TEAR SEAL	.014
SHEET SIZE	12 1/4 X 9 1/4	STYLE CASE	VRB W/FLAP	BAR SEAL	253
CAP.	1 1/2"	DUE DATE	9-15-97	COMPLETED	
LOCATION	I-4-2	QUANTITY	200	DATE	9-5-97

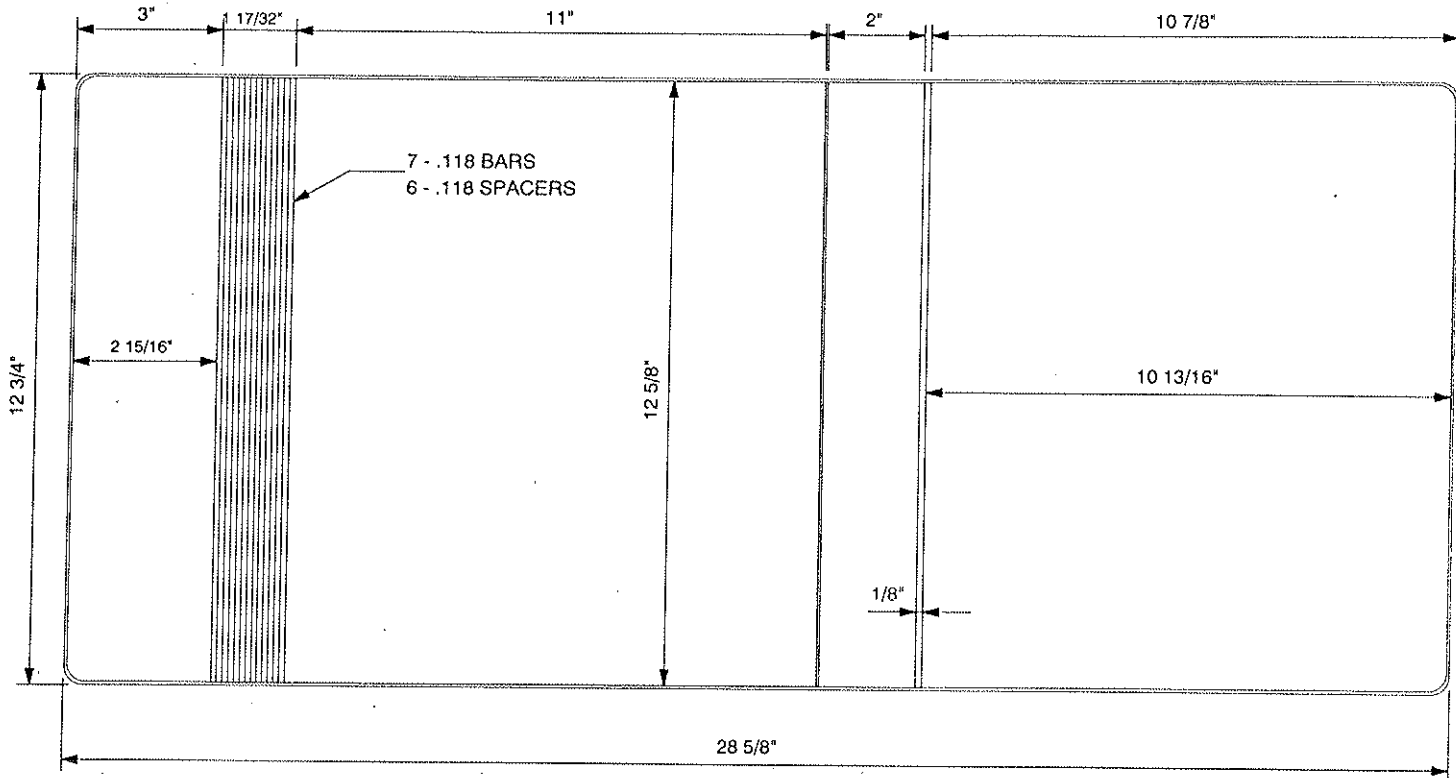

MATERIAL SPECS		GAUGE		MATERIAL SPECS		GAUGE	
COVER MAT.	13 3/4 X 29 5/8		1	LINING MAT.	13 1/2 X 29 3/8		1
COVER MAT.				LINING MAT.			
DIE CUT				HORZ. PKT.	12 7/8 X 11 3/8		1
COL	12 7/8 X 3 1/2		1	VERT. PKT.			
LABEL HOLDER	3 X 2 1/2		1	DIE CUT			
GUSSET				REINF.			
BOARD SPECS		GAUGE		BOARD SPECS		GAUGE	
F.C. BOARD	12 17/32 X 10 23/32	100	1	F.C. BOARD			
B.B. BOARD	12 17/32 X 1 29/32	100	1	B.B. BOARD			
B.C. BOARD	12 17/32 X 10 29/32	100	1	B.C. BOARD			
FLAP BD.	12 17/32 X 2 27/32	100	1	DIE CUT			
BOARD				DIE CUT			

DIE #	6419	METAL	6 3/4" - 1 1/2" LOC	RADIUS	3/8"
ORDER #	989061	CUSTOMER	CSX TRANSPORTATION	TEAR SEAL	.010
SHEET SIZE	6 3/4 X 6	STYLE CASE	VINYL BINDER W/FLAP	BAR SEAL	253-178
CAP.	1 1/2"	DUE DATE	4-20-98	COMPLETED	
LOCATION	G-11-8	QUANTITY	4500	DATE	1-22-98

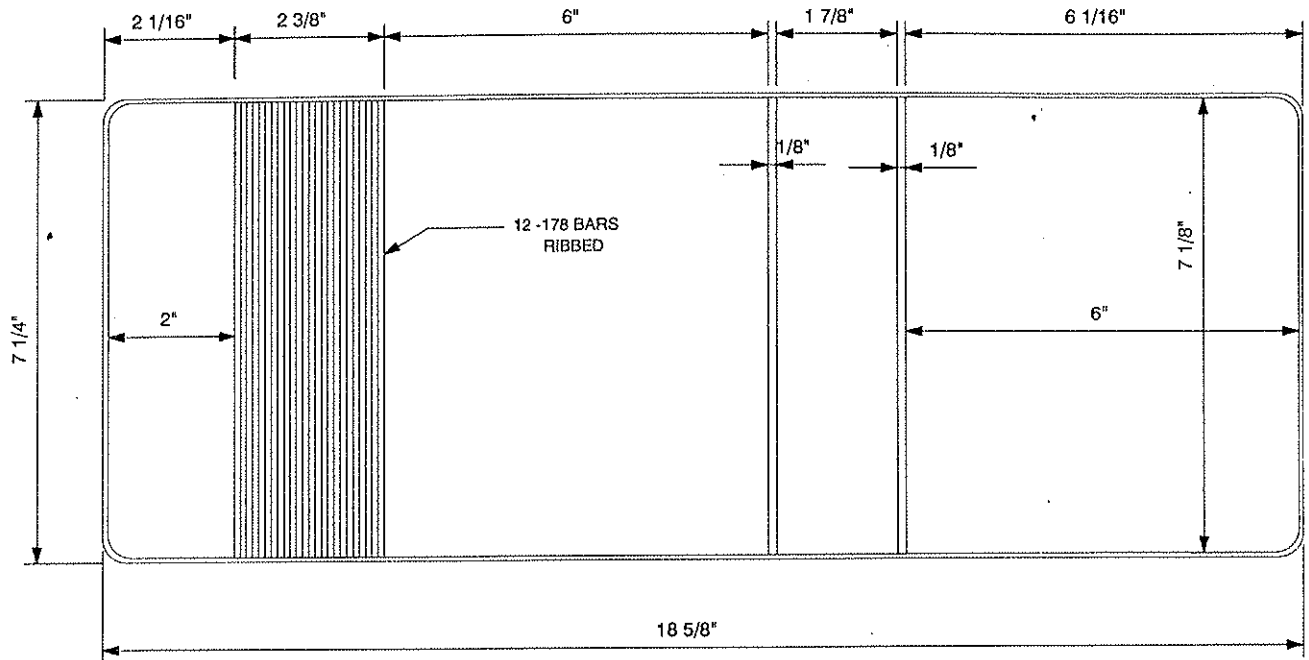

MATERIAL SPECS		GAUGE		PCS.		MATERIAL SPECS		GAUGE		PCS.	
COVER MAT.	8 X 19 3/8			1		LINING MAT.	8 X 19 3/8			1	
COVER MAT.						LINING MAT.					
DIE CUT						HORZ. PKT.	3 1/2 X 6 1/4			1	
COL						VERT. PKT.					
LABEL HOLDER						DIE CUT					
GUSSET						REINF.					
BOARD SPECS		GAUGE		PCS.		BOARD SPECS		GAUGE		PCS.	
F.C. BOARD	7 1/16 X 5 15/16	100	1			F.C. BOARD					
B.B. BOARD	7 1/16 X 1 25/32	100	1			B.B. BOARD					
B.C. BOARD	7 1/16 X 5 15/16	100	1			B.C. BOARD					
FLAP BD.	7 1/16 X 1 29/32	100	1			DIE CUT					
BOARD						DIE CUT					

DIE #	7330	METAL	STR D. NB	RADIUS	3/8"
ORDER #	521199	CUSTOMER	PRINT PROMOTIONS	TEAR SEAL	.014
SHEET SIZE	11 3/8 X 9 3/4	STYLE CASE	VINYL BINDER W/FLAP	BAR SEAL	254-178
CAP.	1 1/2"	DUE DATE	10-25-02	COMPLETED	
LOCATION		QUANTITY	500	DATE	10-14-02

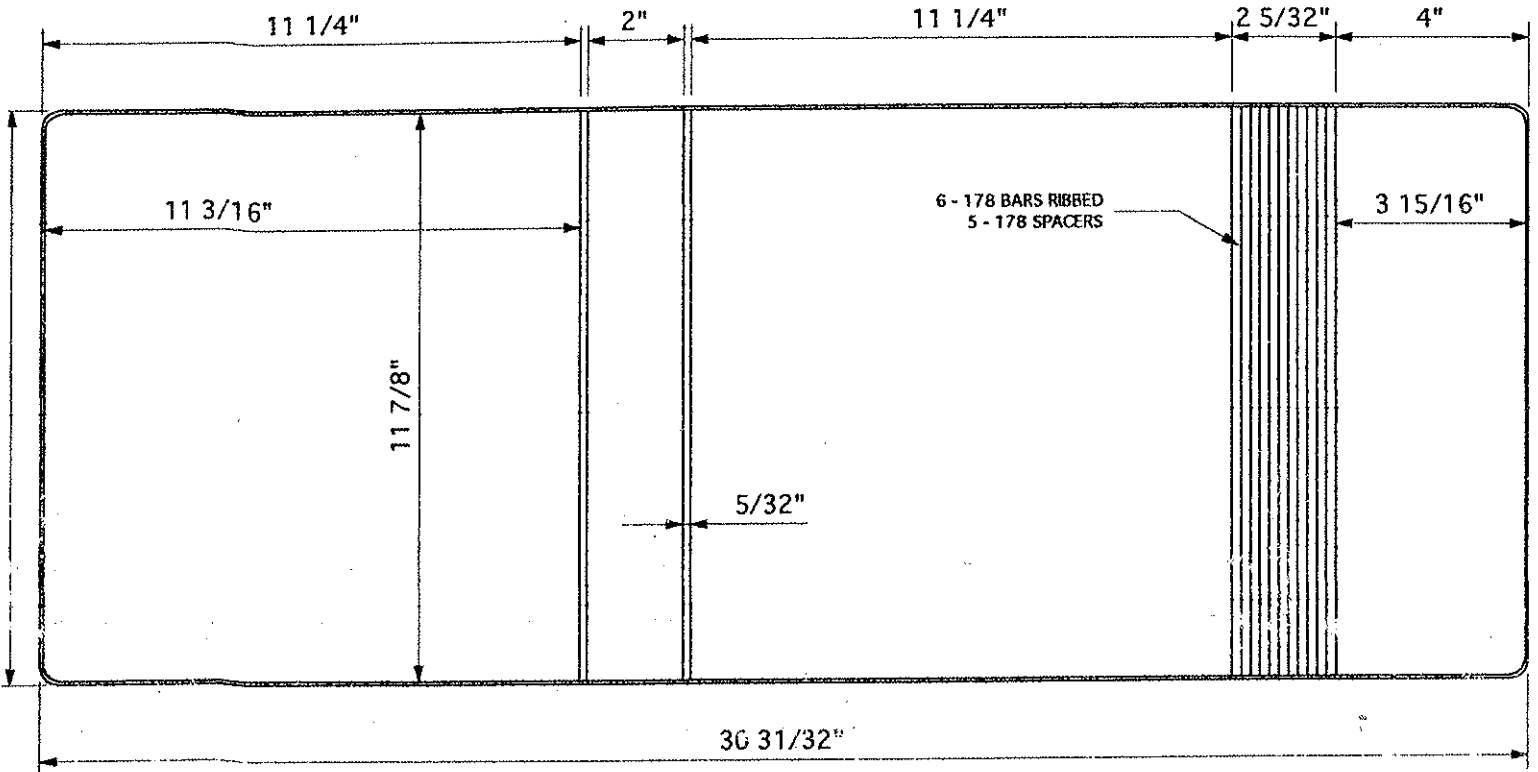

MATERIAL SPECS		GAUGE	PCS.	MATERIAL SPECS		GAUGE	PCS.
COVER MAT.	12 3/4 X 31 3/4		1	LINING MAT.	12 3/4 X 31 3/4		1
COVER MAT.	12 3/4 X 31 3/4		1	LINING MAT.			
DIE CUT				HORZ. PKT.	5 3/8 X 31 3/4		1
COL				VERT. PKT.			
LABEL HOLDER				DIE CUT			
GUSSET				REINF.			
BOARD SPECS		GAUGE	PCS.	BOARD SPECS		GAUGE	PCS.
F.C. BOARD	11 13/16 X 11 1/8	100	1	F.C. BOARD			
B.B. BOARD	11 13/16 X 1 29/32	100	1	B.B. BOARD			
B.C. BOARD	11 13/16 X 11 3/16	100	1	B.C. BOARD			
FLAP BD.	11 13/16 X 3 27/32	100	1	DIE CUT			
BOARD				DIE CUT			