

Product Code

Style Case *Doc Folder w/ VHS TRA*

Sheet Size *11 1/2 x 10* Cap. *1 1/4*

Die No. *4621*

Order No. *967489*

Plate

Customer

Louis Business Products

Metal
Total Vinyl
Quantity
Date
Type Corners
Radius
Completed

.014 rule reversed

	Gauge	Thick
Tear Seal	<i>.014</i>	<i>1/16</i>
Bar Seal	<i>48-3mm</i>	<i>1/8"</i>
Bar Seal		

Rev.

	No. of Feet
Tear Seal	
Bar Seal	
Bar Seal	

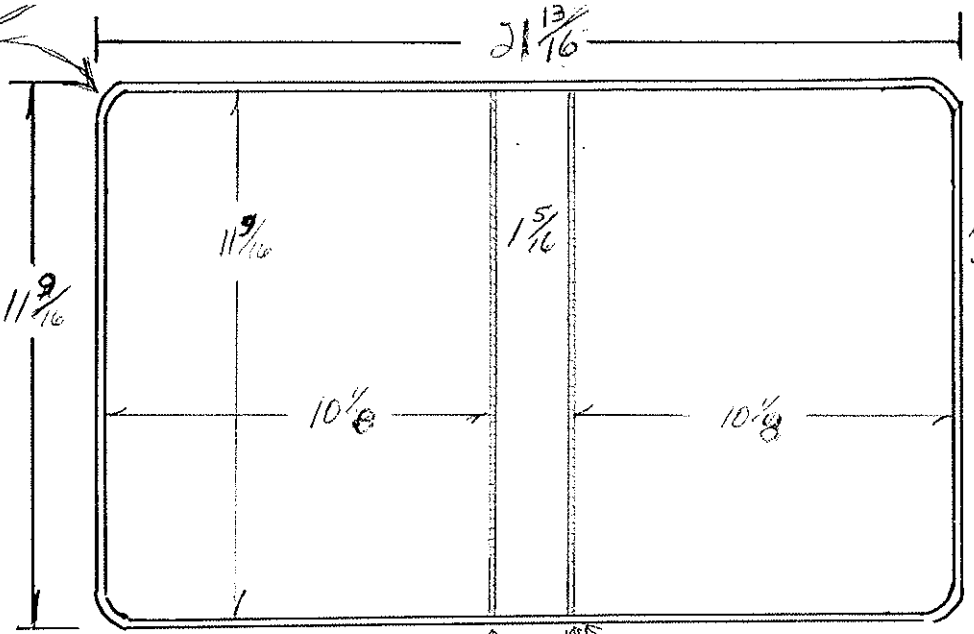

* MATERIAL EXTRA wide.
STRAP TO BE MADE AT SAME TIME ON EDGE OF BINDER.

Dwg - KP
✓ by - B.P

Code		1/4		Ga.		# PCS		Cutting Specs		Code		1/4		Ga.		# Pcs.		Cutting Specs.	
								Size	Out									Size	Out
Cover Mat.		<i>12 1/4</i>	X	<i>24 3/4</i>		<i>12</i>	<i>1</i>			Lining Mat.		<i>12 1/4</i>	X	<i>24 3/4</i>		<i>12</i>	<i>1</i>		
Cover Mat.			X							Lining Mat.			X						
Vert. Pckt.			X							Horz. Pckt.			X						
Vert. Pckt.			X							Horz. Pckt.			X						
Pocket			X							Pocket		<i>9 3/8</i>	X	<i>7 7/8</i>		<i>12</i>	<i>1</i>		
Label Holder			X							Card Hlder			X						
Material	<i>CD</i>	<i>11 1/16</i>	X	<i>10 1/2</i>		<i>8</i>	<i>1</i>			Material			X						
Material			X							Material			X						
Material			X							Material			X						
F.C. Board		<i>11 7/16</i>	X	<i>10</i>		<i>100</i>	<i>1</i>			B.C. Board			X						
B.C. Board		<i>11 7/16</i>	X	<i>10</i>		<i>100</i>	<i>1</i>			B.B. Board		<i>11 7/16</i>	X	<i>1 3/16</i>		<i>100</i>	<i>1</i>		
Center Board			X							Board			X						
Board			X							Strip			X						
Cover Pad			X							Strip			X						
										B.B. Pad			X						

Product Code

Style Case VINYL FOLDER / VRS

Sheet Size 11 X 9

Cap. 1

Die No. 4670

Order No. 967872

Plate C-11-7

Customer

PHILIP CROSBY ASSOCIATES

Metal
Total Vinyl
Quantity 5,000
Date 2-22-91
Type Corners
Radius
Completed

	Gauge	Thick
Tear Seal	014	1/8
Bar Seal	#253C	1/8
Bar Seal		

	No. of Feet
Tear Seal	
Bar Seal	
Bar Seal	

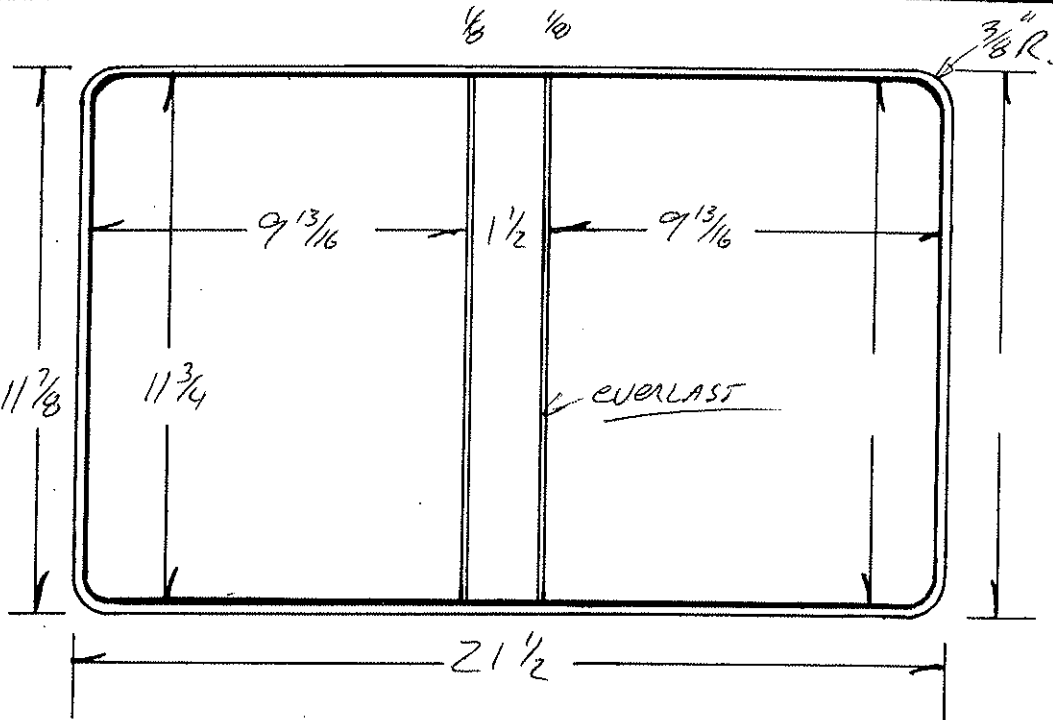

SIZE - B. PAGE
CHECK *(Signature)*

PADED 80 DIE # 4500

Code		Ga.	#	PCS	Size	Out	Cutting Specs	Code		Ga.	#	PCS	Size	Out	Cutting Specs	
Cover Mat.					12 5/8 X 22 1/4	14	1		Lining Mat.				12 5/8 X 22 1/4	14	1	
Cover Mat.	Padded				12 7/8 X 22 1/2				Lining Mat.				X			
Vert. Pckt.					12 5/8 X 9 1/4	14	1		Horz. Pckt.				X			
Vert. Pckt.					X				Horz. Pckt.				5 3/8 X 10 3/8	14	1	
Pocket					X				Pocket				X			
Label Holder					X				Card Holder				X			
Material					X				Material				X			
Material					X				Material				X			
Material					X				Material				X			
F.C. Board	Padded				11 5/8 X 9 11/16	100	1		B.C. Board				X			
B.G. Board	Padded				11 5/8 X 9 11/16	100	1		B.B. Board				11 5/8 X 1 3/8	100	1	
Center Board					X				Board				X			
Board					X				Strip				X			
Cover Pad					X				Strip				X			
									B.B. Pad				X			

Product Code

Style Case *VINYL FOLDER W/PATS*

ACTUAL
Sheet Size *9* X *6 1/4*

Cap. *1 3/16*

Die No. *4893*

Order No. *970273*

Plate *C-19-7*

Customer

R.R. DONNELLEY / IBM

10-21

Metal
Total Vinyl
Quantity <i>1000</i>
Date <i>10-9-91</i>
Type Corners
Radius
Completed

	Gauge	Thick
Tear Seal	<i>.014</i>	<i>1/16</i>
Bar Seal	<i>+23 HFT</i>	<i>1/16</i>
Bar Seal		

	No. of Feet
Tear Seal	
Bar Seal	
Bar Seal	

DWY - B. Mac
CHELA
CPW

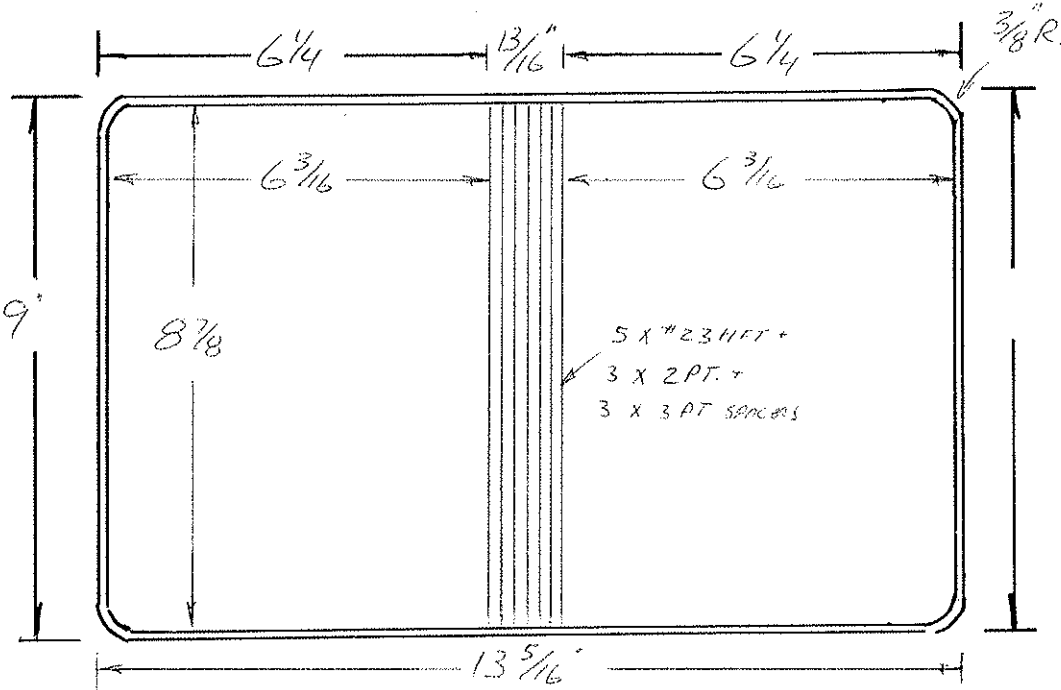

PER SAMPLE

		Cutting Specs						Cutting Specs			
Code		Ga.	# PCS	Size	Out	Code		Ga.	# Pcs.	Size	Out
Cover Mat.	<i>9 3/4 X 14 1/8</i>	<i>14</i>	<i>1</i>			Lining Mat.	<i>9 3/4 X 14 1/8</i>	<i>14</i>	<i>1</i>		
Cover Mat	X					Lining Mat.	X				
Vert. Pckt.	<i>IBC 9 3/4 X 3 7/8</i>	<i>8</i>	<i>1</i>			Horz. Pckt.	<i>JFL 3 7/8 X 6 3/4</i>	<i>8</i>	<i>1</i>		
Vert. Pckt.	<i>IBC 9 3/4 X 6 1/8</i>	<i>8</i>	<i>1</i>			Horz. Pckt.	X				
Pocket	X					Pocket	X				
Label Holder	X					Card Holder	X				
Material	X					Material	X				
Material	X					Material	X				
Material	X					Material	X				
F.C. Board	<i>9 1/16 X 6 1/8</i>	<i>100</i>	<i>1</i>			B.C. Board	X				
B.G. Board	<i>9 1/16 X 6 1/8</i>	<i>100</i>	<i>1</i>			B.B. Board	X				
Center Board	X					Board	X				
Board	X					Strip	X				
Cover Pad	X					Strip	X				
						B.B. Pad	X				

Product Code

Style Case VINYL FLOOR W/ PATS.

ACTUAL Sheet Size $9\frac{3}{8}$ X $6\frac{1}{4}$

Cap. $\frac{13}{16}$

Die No. 4897

Order No. 970355

Plate C-19-9

Customer

RR DONNELLEY / IBM

10-21

Metal
Total Vinyl
Quantity 700
Date 10-16-91
Type Corners
Radius $\frac{3}{8}$ "
Completed

	Gauge	Thick
Tear Seal	.014	$\frac{1}{16}$
Bar Seal	.253+	Sec. Draw.
Bar Seal		

	No. of Feet
Tear Seal	
Bar Seal	
Bar Seal	

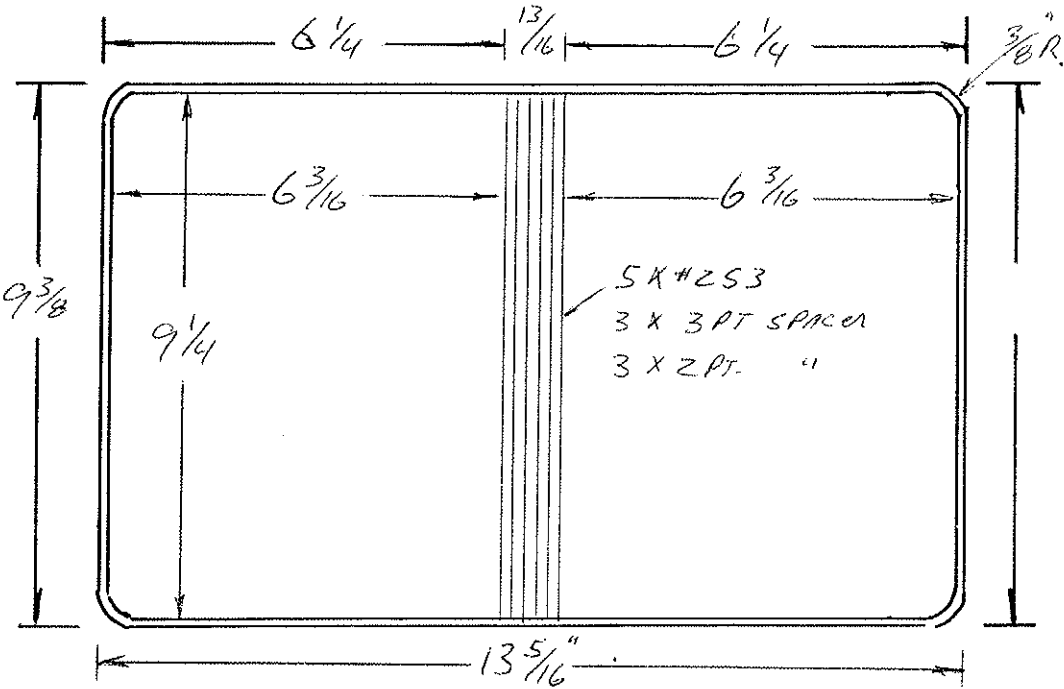

Dwg - B. Plate
 Check - KPT

Code	Ga.	PCS	Cutting Specs		Code	Ga.	Pcs.	Cutting Specs			
			Size	Out				Size	Out		
Cover Mat.			$10\frac{1}{8}$ X $14\frac{1}{8}$	14	1	Lining Mat.			$10\frac{1}{8}$ X $14\frac{1}{8}$	14	1
Cover Mat.			X			Lining Mat.			X		
Vert. Pckt.	IBC		$10\frac{1}{8}$ X $6\frac{3}{4}$	8	1	Horz. Pckt.	IBC		$3\frac{7}{8}$ X $6\frac{3}{4}$	8	1
Vert. Pckt.			X			Horz. Pckt.			$3\frac{5}{8}$ X $6\frac{3}{4}$	8	1
Pocket			X			Pocket	HORZ		$3\frac{7}{8}$ X $6\frac{3}{4}$	8	1
Label Holder			X			Card Hlder			X		
Material			X			Material			X		
Material			X			Material			X		
Material			X			Material			X		
F.C. Board			$9\frac{3}{16}$ X $6\frac{1}{8}$	100	1	B.C. Board			X		
B.C. Board			$9\frac{3}{16}$ X $6\frac{1}{8}$	100	1	B.B. Board			X		
Center Board			X			Board			X		
Board			X			Strip			X		
Cover Pad			X			Strip			X		
						B.B. Pad			X		

Product Code

OLD# 901

Style Case VINYL FOLDER

Sheet Size 11 x 9

Cap. 1/4" Die No. 5063

Order No. 62898

Plate D-7-7

EBSCO - DAS

6-1

Customer

Metal
Total Vinyl
Quantity 250
Date 5-14-92
Type Corners
Radius
Completed

	Gauge	Thick
Tear Seal	.012	1/16
Bar Seal	#253 XZ	1/4"
Bar Seal		

	No. of Feet
Tear Seal	
Bar Seal	
Bar Seal	

Dwg. B. Pace

CHECK.

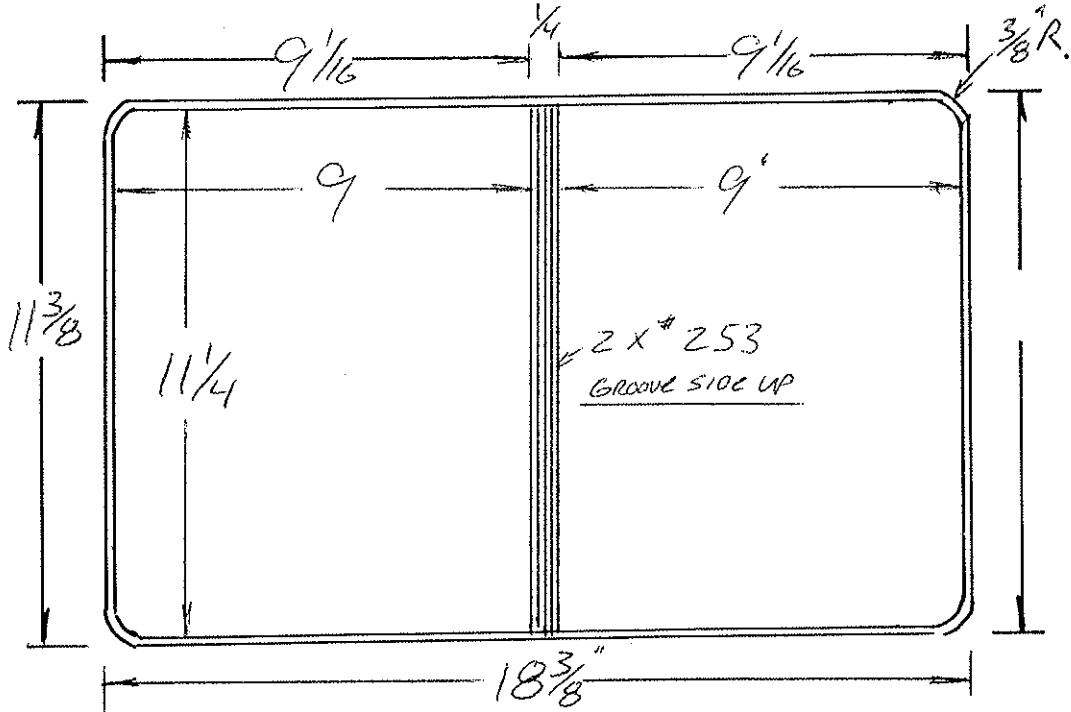

Code	Ga.	Pcs	Cutting Specs		Code	Ga.	Pcs	Cutting Specs	
			Size	Out				Size	Out
Cover Mat.		12 1/4 x 19 1/8	12	1	Lining Mat.		12 1/4 x 19 1/8	12	1
Cover Mat.		X			Lining Mat.		X		
Vert. Pckt.		12 1/8 x 9 3/16	8	2	Horz. Pckt.		X		
Vert. Pckt.		X			Horz. Pckt.		X		
Pocket		X			Pocket		X		
Label Holder		X			Card Holder		X		
Material		X			Material		X		
Material		X			Material		X		
Material		X			Material		X		
F.C. Board		11 3/16 x 8 15/16	100	1	B.C. Board		X		
B.C. Board		11 3/16 x 8 15/16	100	1	B.B. Board		X		
Center Board		X			Board		X		
Board		X			Strip		X		
Cover Pad		X			Strip		X		
					B.B. Pad		X		

Product Code OLD# 3059 Style Case VINYL FOLDER

Size 6 7/16 X 4 1/16 Cap. 1/8 Die No. 5078 Order No. 972492 Plate D-8-2

SOCIETY OF ST. PAUL 6-18

Customer

Metal
Total Vinyl
Quantity <u>5,000</u>
Date <u>6-1-92</u>
Type Corners
Radius <u>1/8"</u>
Completed

	Gauge	Thick
Tear Seal	<u>.012</u>	<u>1/16</u>
Bar Seal	<u>.008</u>	<u>1/16</u>
Bar Seal		

	No. of Feet
Tear Seal	
Bar Seal	
Bar Seal	

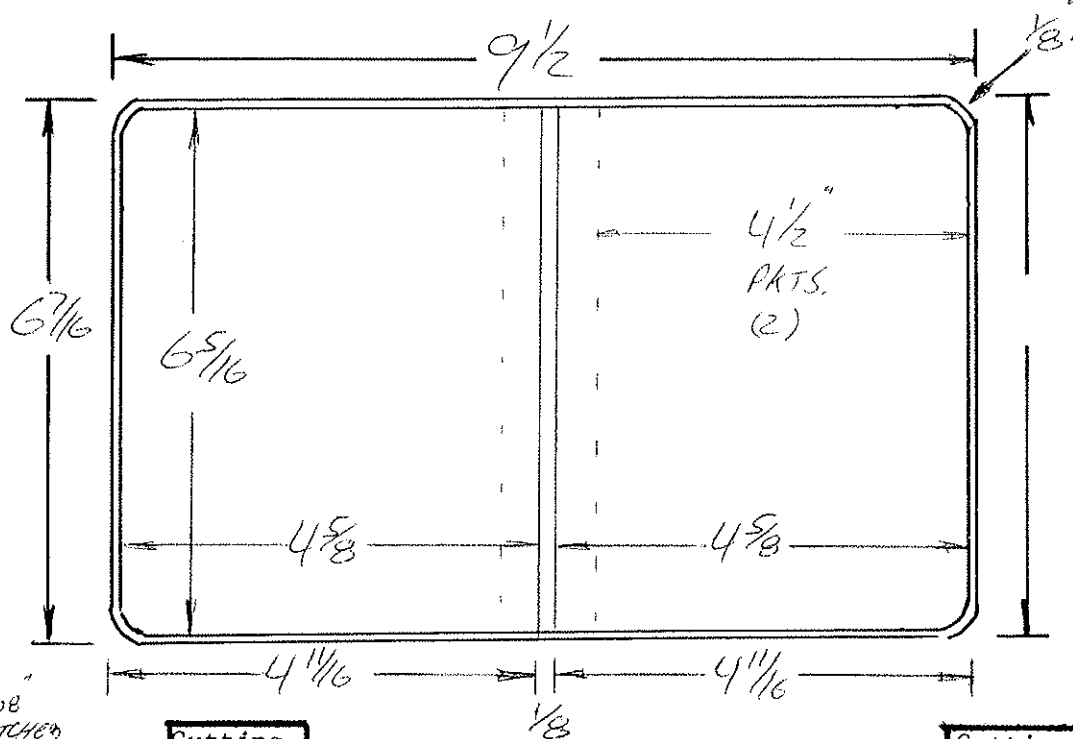

DWG. - B. Praeger
 Check - *[Signature]*

	Ga.	# PCS	Cutting Specs		Code	Ga.	# Pcs.	Cutting Specs	
			Size	Out				Size	Out
Cover Mat.		15							
		1							
Cover Mat.					Lining Mat.			X	
					Lining Mat.			X	
Vert. Pckt.					Horz. Pckt.			X	
					Horz. Pckt.			X	
Pocket					Pocket			X	
Label Holder					Card Hlder			X	
Material					Material			X	
Material					Material			X	
Material					Material			X	
F.C. Board					B.C. Board			X	
B.C. Board					B.B. Board			X	
Center Board					Board			X	
Board					Strip			X	
Cover Pad					Strip			X	
					B.B. Pad			X	

Product Code

Style Case Vinyl Cover

Actual Sheet Size $10\frac{3}{16} \times 14\frac{7}{16}$ Cap.

Die No. 5179

Order No. 63739

Plate D12-6

Customer

FBS/O Media

10-23

Metal
Total Vinyl
Quantity 9500
Date 10-9-92
Type Corners RNd
Radius $\frac{3}{8}$
Completed

	Gauge	Thick
Tear Seal	.008	$\frac{7}{16}$
Bar Seal		
Bar Seal		

	No. of Feet
Tear Seal	
Bar Seal	
Bar Seal	

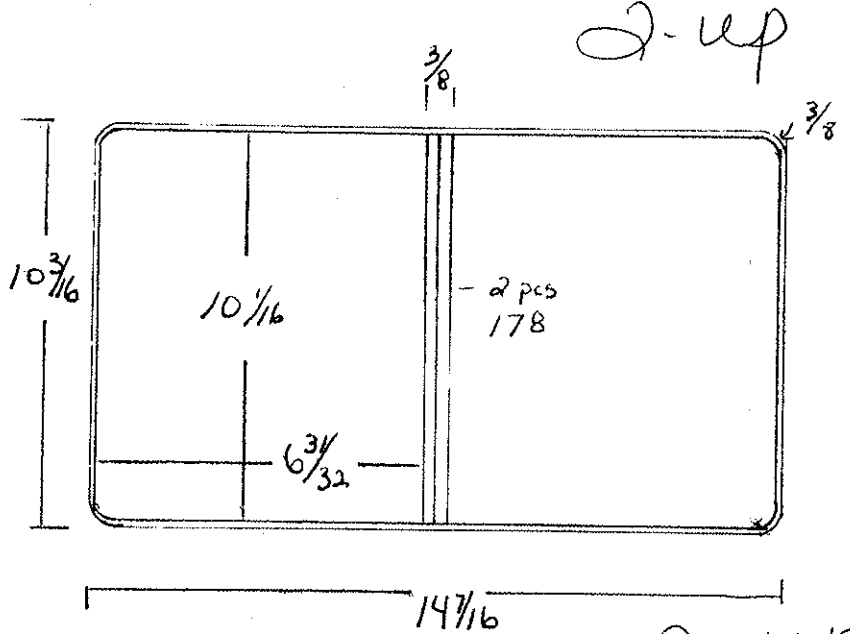

Tim

2-up

Code	Ga.	#	PCS	Cutting Specs		Code	Ga.	#	PCS	Cutting Specs	
				Size	Out					Size	Out
Cover Mat.			1			Lining Mat.			X		
Cover Mat.						Lining Mat.			X		
Vert. Pckt.			1			Horz. Pckt.			X		
Vert. Pckt.			1			Horz. Pckt.			X		
Pocket						Pocket			X		
Label Holder						Card Hlder			X		
Material						Material			X		
Material						Material			X		
Material						Material			X		
F.C. Board						B.C. Board			X		
B.C. Board						B.B. Board			X		
Center Board						Board			X		
Board						Strip			X		
Cover Pad						Strip			X		
						B.B. Pad			X		

Product Code

Style Case

Vinyl folder

Overall

Sheet Size 9 x 6

Cap.

Die No. 5799

Order No. 973869.1

Plate D13-8

Customer

RR Donnelley & Sons

11-24

Metal
Total Vinyl
Quantity 2500
Date 11-12-92
Type Corners RWD
Radius 3/8
Completed

1/4

1/2

	Gauge	Thick
Tear Seal	Sec Dwg	Not edge
Bar Seal	Sec Dwg	
Bar Seal		

	No. of Feet
Tear Seal	
Bar Seal	
Bar Seal	

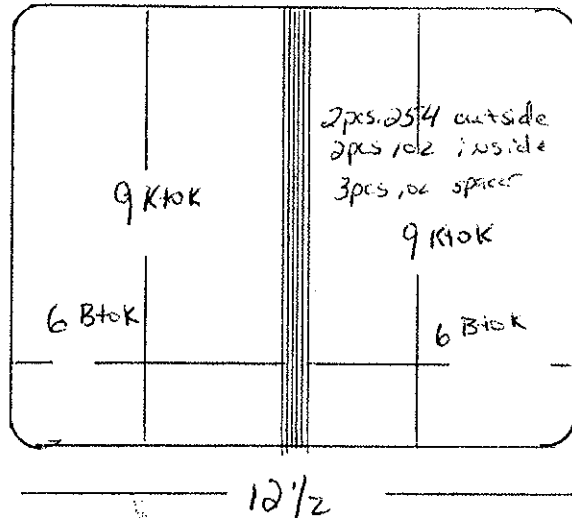

Tim

Code	Ga.	#	PCS	Cutting Specs		Code	Ga.	#	Pcs.	Cutting Specs	
				Size	Out					Size	Out
Cover Mat.			1	9 3/4	13 1/4	Lining Mat.			1	9 3/4	13 1/4
Cover Mat.				X		Lining Mat.				X	
Vert. Pckt.			1	9 3/4	5 3/4	Horz. Pckt. COL			1	9 1/2	6 3/8
Vert. Pckt.				X		Horz. Pckt.				X	
Pocket				X		Pocket				X	
Label Holder				X		Card Holder				X	
Material				X		Material				X	
Material				X		Material				X	
Material	Ding Pkt.		1	7 1/2	6	Material				X	
F.C. Board			1	8 29/32	5 29/32	B.C. Board			1	8 7/8	5 7/8
B.C. Board			1	8 29/32	5 29/32	B.B. Board				X	
Center Board				X		Board			1	8 7/8	5 7/8
Board				X		Strip				X	
Cover Pad				X		Strip				X	
						B.B. Pad				X	

DIE # 5254	STYLE CASE Vinyl folder Pkt	LOCATION D15-5
SHEET SIZE 7 3/4 x 9	CAP.	ORDER NO. 974296
CUSTOMER Vulcan Binder & Cover		DUE DATE 1-19-93

QUANTITY	25
DATE	1-18-93

RADIUS	1/4
COMPLETED	

TEAR SEAL	.014
BAR SEAL	1/16

1/16 1/16
" "

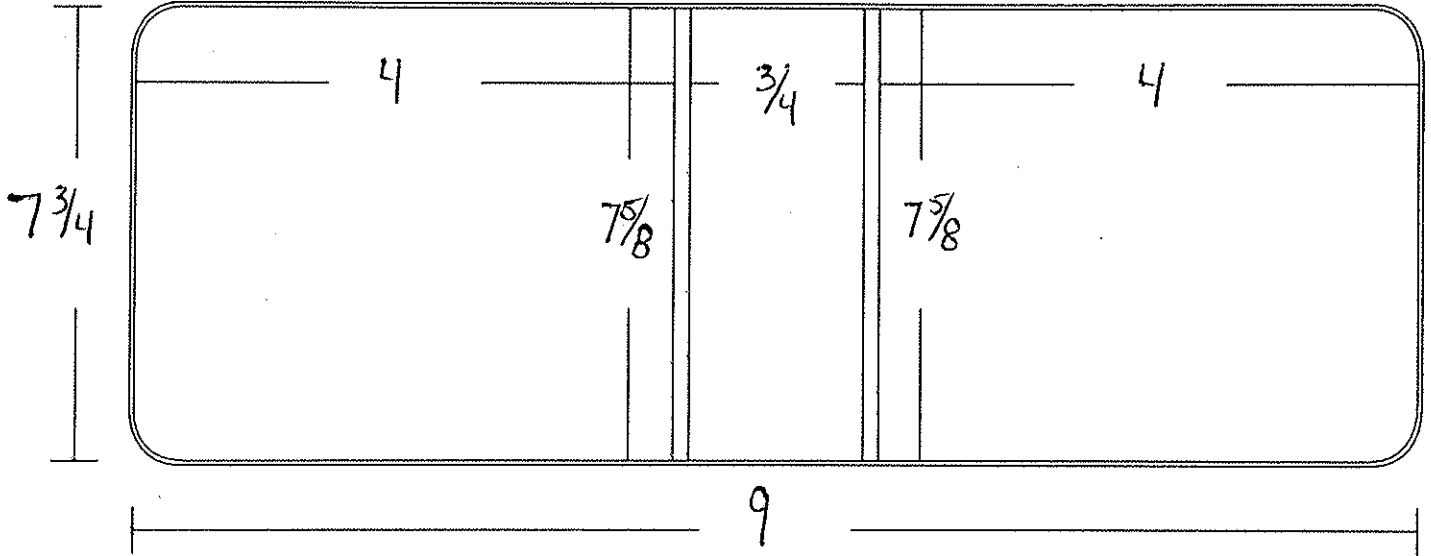

MATERIAL

	CODE	GA	PCS		CODE	GA	PCS
COVER MATL		8 1/2	X 9 3/4	LINING		8 1/2	X 9 3/4
COVER MATL			X	LINING			X
VERT PKT			X	HORZ PKT		3	X 9 3/4
VERT PKT			X	HORZ PKT		3 1/2	X 9 3/4
CARD HOLDER			X	DIAGONAL PKT			X
COL			X	LABEL HOLDER			X
EX. COL			X	GUSSETT			X
			X	REINF.			X
			X				X

PRINTS

FRONT COVER	X	BACK BONE	X	BACK COVER	X
-------------	---	-----------	---	------------	---

BOARDS

	CODE	PT	PCS		CODE	PT	PCS
F.C. BOARD			7 9/16 X 3 1/16	B.C. BOARD			7 9/16 X 3 1/16
B.B. BOARD			X	B.B. BOARD			X
B.C. BOARD			X	B.C. BOARD			X
B. UP STRIP			X				X
			X				X

DIE #	5255	STYLE CASE	Vinyl Folder Pkt.	LOCATION	D15-6
OA SHEET SIZE	8 $\frac{3}{4}$ x 9	CAP.		ORDER NO.	974295
CUSTOMER	Vulcan Binder & Cover			DUE DATE	1-19-93

QUANTITY	25
DATE	1-18-93

RADIUS	1/4
COMPLETED	

TEAR SEAL	.014
BAR SEAL	102

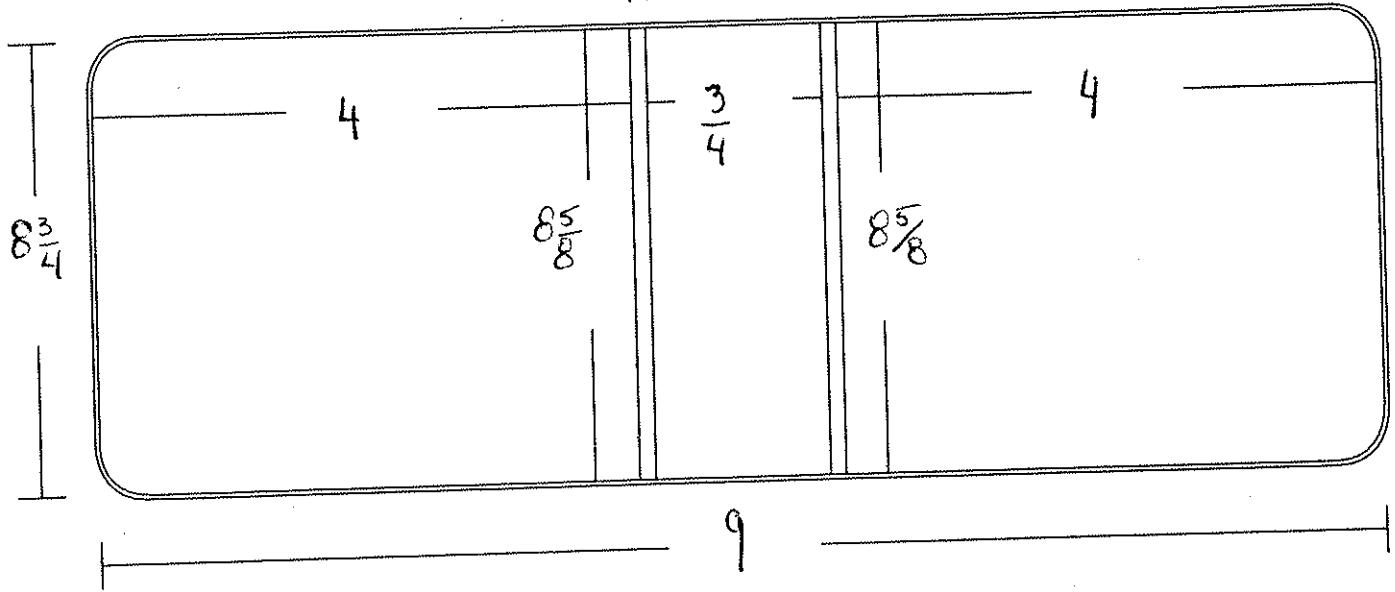

MATERIAL

	CODE	GA	PCS		CODE	GA	PCS		
COVER MATL		9 1/2	X	9 3/4	LINING	9 1/2	X	9 3/4	1
COVER MATL			X		LINING		X		
VERT PKT			X		HORZ PKT	3	X	9 3/4	1
VERT PKT			X		HORZ PKT	3 1/2	X	9 3/4	1
CARD HOLDER			X		DIAGONAL PKT		X		
COL			X		LABEL HOLDER		X		
EX. COL			X		GUSSETT		X		
			X		REINF.		X		
			X				X		

PRINTS

FRONT COVER	X	BACK BONE	X	BACK COVER	X
-------------	---	-----------	---	------------	---

BOARDS

	CODE	PT	PCS		CODE	PT	PCS		
F.C. BOARD		8 9/16	X	3 15/16	B.C. BOARD	8 9/16	X	3 15/16	1
B.B. BOARD			X		B.B. BOARD		X		
B.C. BOARD			X		B.C. BOARD		X		
B. UP STRIP			X				X		
			X				X		

Product Code

Style Case Col Folder

Sheet Size $9\frac{1}{2}$ X 6 Cap.

Die No. 5319 11th B Order No. 974984

Plate D19-2

UPS

Customer

Metal
Total Vinyl
Quantity
Date
Type Corners
Radius
Completed

	Gauge	Thick
Tear Seal	.012	1/6
Bar Seal		
Bar Seal		

nat edge

	No. of Feet
Tear Seal	
Bar Seal	
Bar Seal	

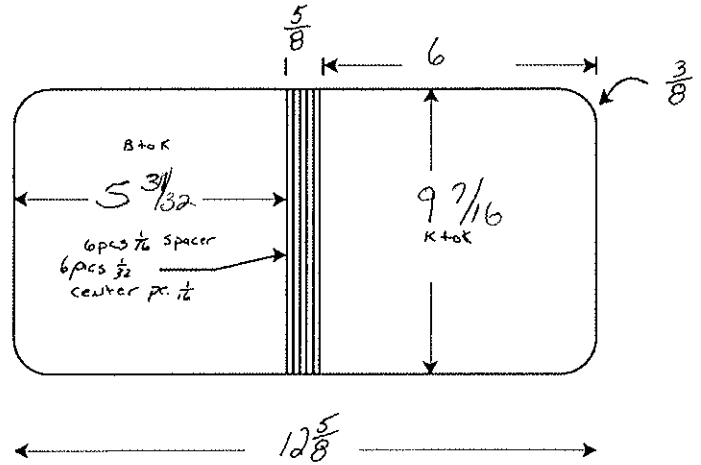

Code		Cutting Specs		Code		Cutting Specs			
		Ga.	# PCS	Size	Out	Ga.	# Pcs.	Size	Out
Cover Mat.	D19A		1	$10\frac{1}{4}$ X $13\frac{3}{8}$		Lining Mat.	1	$10\frac{1}{4}$ X $13\frac{3}{8}$	
Col Cover Mat	A			$9\frac{5}{8}$ X $13\frac{3}{8}$		Lining Mat.		X	
Vert. Pckt.	A		1	$10\frac{1}{4}$ X $5\frac{3}{4}$		Horz. Pcktt.		X	
Vert. Pckt.				X		Hrz. Pcktt.		X	
Pocket	A		1/2	$9\frac{1}{4}$ X $6\frac{3}{8}$		Pocket		X	
Label Holder				(cut in half makes 2)		Card holder		X	
Material				X		Material	B	$9\frac{3}{4}$ X $10\frac{5}{8}$	2
Material				X		Material	B	$3\frac{1}{8}$ X $4\frac{3}{8}$	4
Material				X		Material		X	
F.C. Board	A		100	$9\frac{3}{8}$ X $5\frac{29}{32}$	1	B.C. Board		X	
B.C. Board	A		100	$9\frac{3}{8}$ X $5\frac{29}{32}$	1	B.B. Board		X	
Center Board				X		Board		X	
Board				X		Strip		X	
Cover Pad				X		Strip		X	
						B.B. Pad		X	

Book Cover

DIE # 5344	STYLE CASE VRB	LOCATION E1-8
Actual SHEET SIZE 9 X 10 +	CAP.	ORDER NO. 975284
CUSTOMER NCH Corp		DUE DATE

QUANTITY	250
DATE	6-7-93

RADIUS	3/8
COMPLETED	

TEAR SEAL	.014
BAR SEAL	483

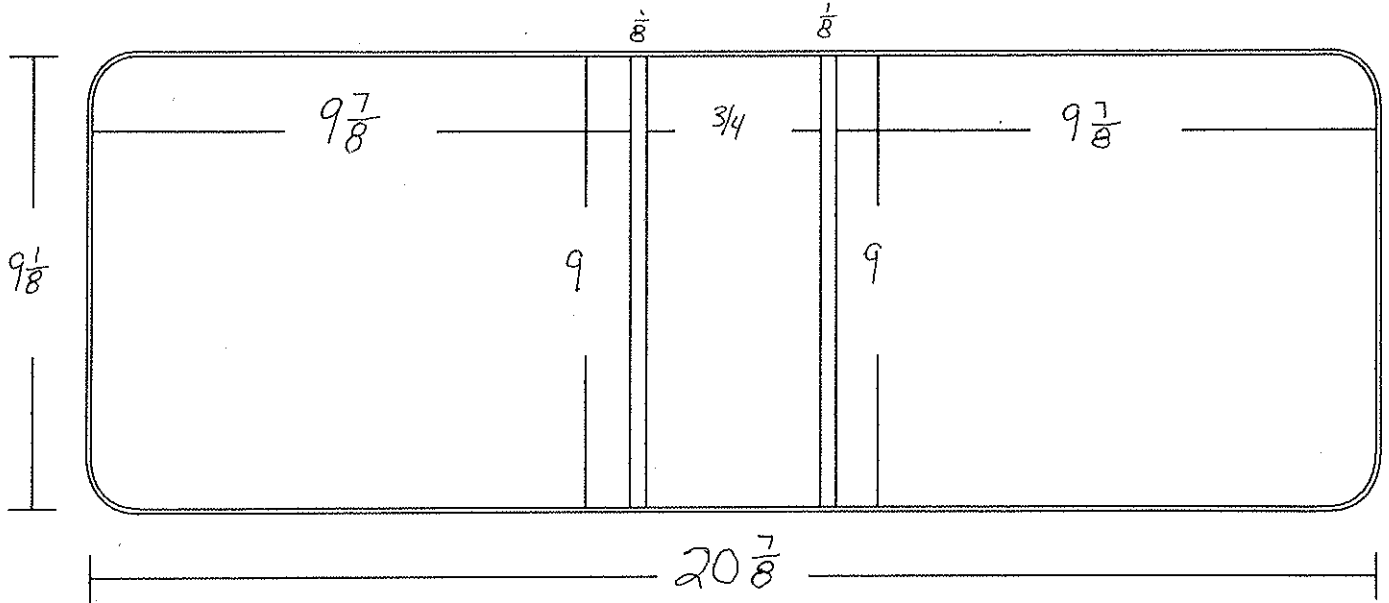

MATERIAL

	CODE		GA	PCS		CODE		GA	PCS
COVER MATL		9 7/8 X 21 5/8		1	LINING		9 7/8 X 21 5/8		1
COVER MATL		X			LINING		X		
VERT PKT		9 7/8 X 9 7/8		1	HORZ PKT		X		
VERT PKT		9 7/8 X 4 1/8		1	HORZ PKT		X		
CARD HOLDER		X			DIAGONAL PKT		X		
COL		X			LABEL HOLDER		X		
EX. COL		X			GUSSETT		X		
		X			REINF.		X		
		X					X		

PRINTS

FRONT COVER	X	BACK BONE	X	BACK COVER	X
-------------	---	-----------	---	------------	---

BOARDS

	CODE		PT	PCS		CODE		PT	PCS
F.C. BOARD		8 15/16 X 9 13/16	100	1	F.C. BOARD		8 29/32 X 9 25/32	120	1
B.B. BOARD		X			B.B. BOARD		X		
B.C. BOARD		8 15/16 X 9 13/16	100	1	B.C. BOARD		8 29/32 X 9 25/32	120	1
B. UP STRIP		X					X		
		X					X		

DIE # 5596		STYLE CASE vinyl folder		LOCATION e 10-8	
SHEET SIZE 8 1/16 x 7 5/8		CAP.		ORDER # 978472	
CUSTOMER camco products and service				DUE DATE 6-16-94	
QUANTITY		RADIUS	.25	TEAR SEAL	.012
DATE		COMPLETED		BAR SEAL	#20

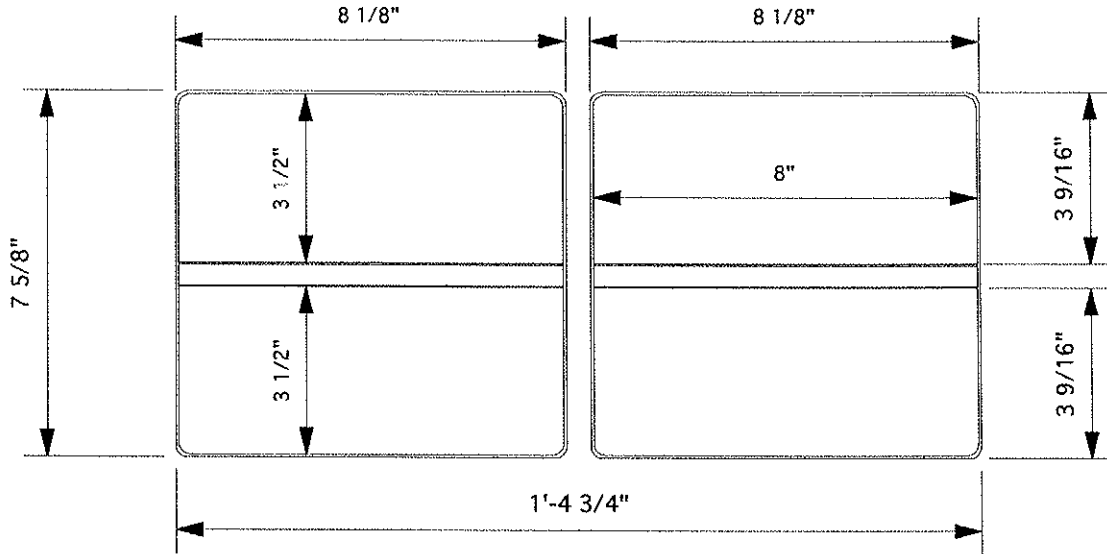

ANY JOBS UNDER 1000 USE 1-UP SIZES

MATERIAL SPECS		GA		PCS		GA		PCS	
COVER MATL	8 5/8 x 17 3/4	2 UP	1	LINING	8 5/8 x 17 3/4	2 UP	1		
1 UP COVER MATL	8 5/8 x 8 7/8	1 UP	1	1 UP LINING	8 5/8 x 8 7/8	1 UP	1		
VERT PKT	3 5/8 x 17 3/4	2 UP	1	HORZ PKT	8 5/8 x 3 5/8	1 UP	1		
VERT PKT	2 3/8 x 17 3/4	2 UP	1	HORZPKT	8 5/8 x 2 3/8	1 UP	1		
CARD HOLDER				DIAGONAL PKT					
COL				LABEL HOLDER					
EX COL				GUSSETT					
				REINF					

BOARD SPECS					
F.C. BOARD	7 15/16 x 3 7/16	6	2	F.C. BOARD	
B.B. BOARD				B.B. BOARD	
B.C. BOARD				B.C. BOARD	
BU STRIP					

DIE # 5683		CAP.		METAL NONE	
STYLE CASE VINYL FOLDER				LOCATION E-15-8	
SHEET SIZE			ORDER # 979589		
CUSTOMER H E HARIS				DUE DATE 11-04094	
QUANTITY	2000	RADIUS		TEAR SEAL	.014
DATE	10-11-94	COMPLETED		BAR SEAL	253

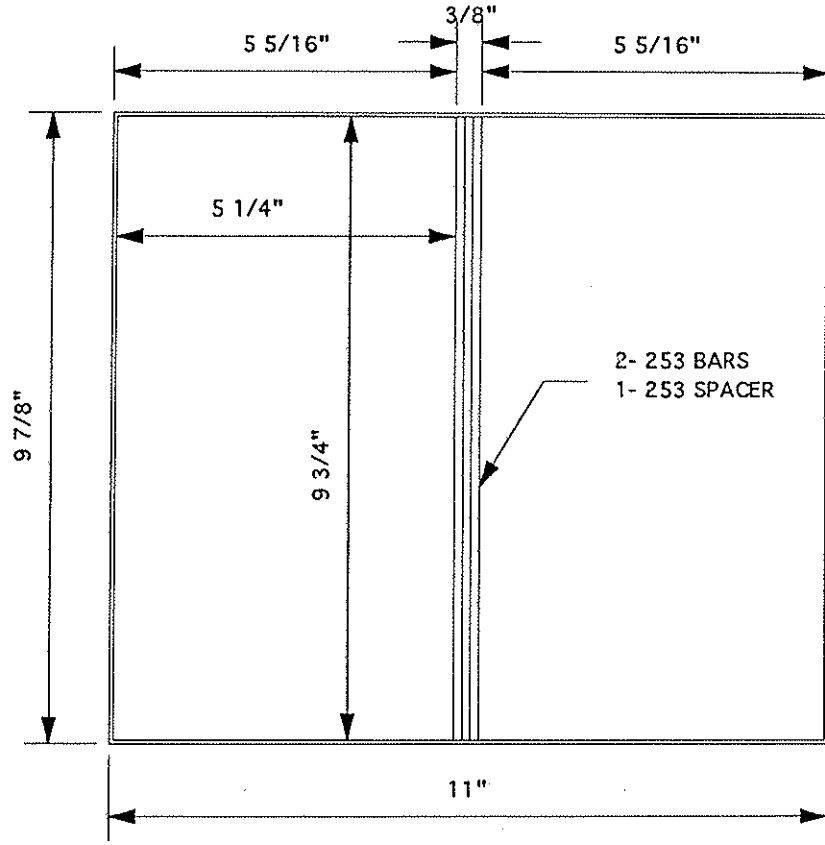

MATERIAL SPECS		GA	PCS	GA		PCS
COVER MAT.	10 5/8 X 11 3/4		1	LINING MAT	10 5/8 X 11 3/4	1
COVER MAT.				LINING MAT		
VERT PKT	10 5/8 X 5 1/2		1	HORZ PKT	9 X 5 3/4	1
CARD HOLDER				GUSSET		
COL				DIAGONAL PKT		
LABEL HOLDER				REINF		

BOARD SPECS		GA	PCS	GA		PCS
F.C. BOARD	9 11/16 X 5 3/16	100	1	F.C. BOARD		
B.B. BOARD	9 11/16 X 5 3/16	100	1	B.B. BOARD		
B.C. BOARD				B.C. BOARD		
B.U. STRIP						

DIE #	5881	METAL		RADIUS	1/4
ORDER #	982177	CUSTOMER	CENTRAL FLORDIA INVESTMENT	TEAR SEAL	.014
SHEET SIZE	11 X 9	STYLE CASE	VINYL PADHOLDER	BAR SEAL	102
CAP.		DUE DATE	8-7-95	COMPLETED	
LOCATION	F-10-3 + Q-4	QUANTITY	1000	DATE	8-2-95

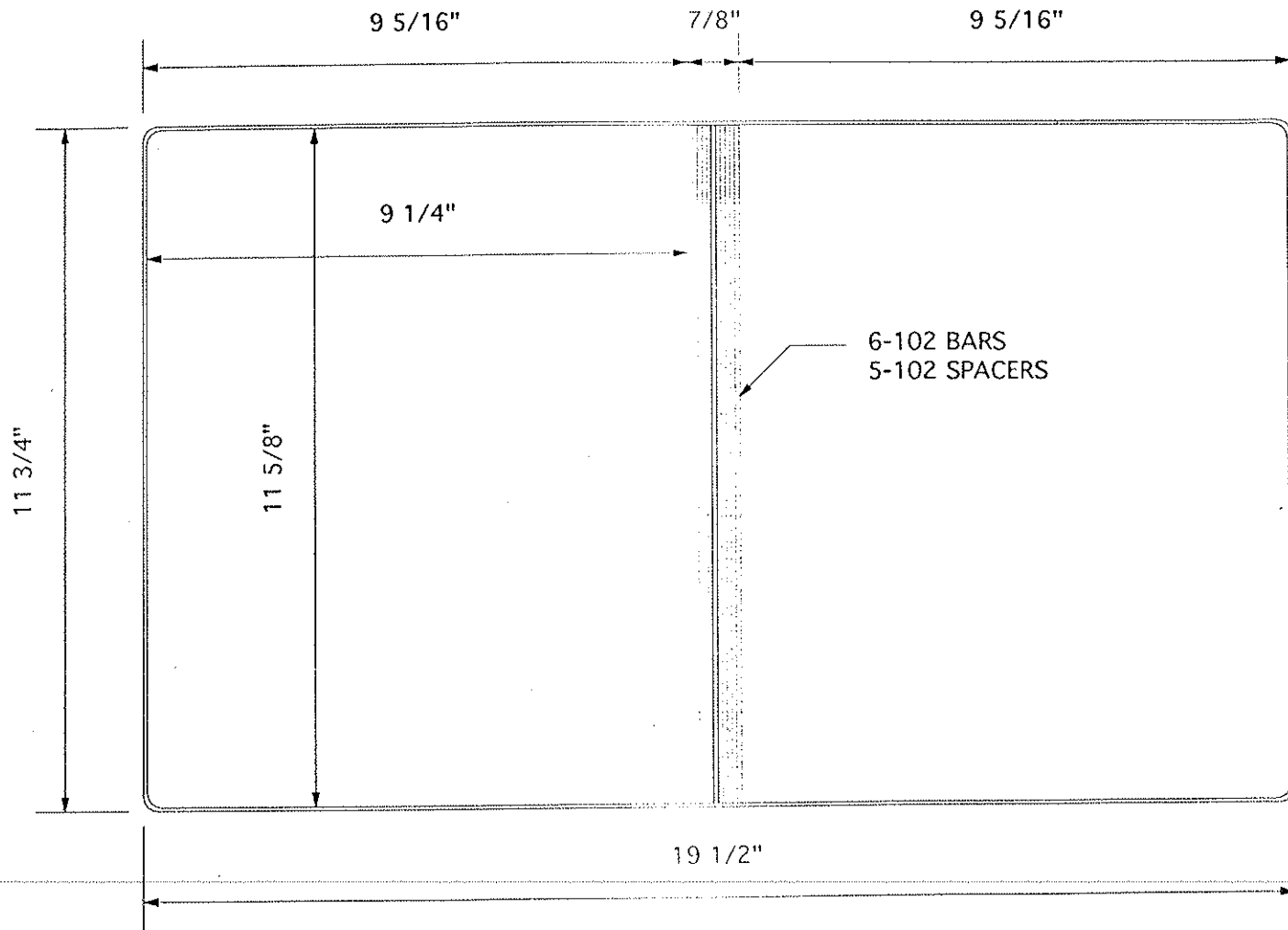

MATERIAL SPECS		GAUGE	PCS	MATERIAL SPECS		GAUGE
COVER MAT.	12 1/2 X 20 1/4		1	LINING MAT.	12 1/2 X 20 1/4	
COVER MAT.				HORZ. PKT.	5 3/8 X 20 1/2	
LABEL HOLDER				DIE CUT		
FORMED PKT.				REINF.		
BOARD SPECS		GAUGE	PCS	BOARD SPECS		GAUGE
F.C. BOARD	11 9/16 X 9 3/16	100	1	PKT. BOARD	5 1/8 X 9	120
B.C. BOARD	11 9/16 X 9 3/16	100	1	B.C. BOARD	ROUND CORNER ONE CORNER	

DIE #	5981-R	METAL		RADIUS	1/4
ORDER #	72555	CUSTOMER	UNLIMITED GRAPHICS	TEAR SEAL	.014
SHEET SIZE	9 X 4	STYLE CASE	2 UP VINYL POCKET FOLDER	BAR SEAL	253 RIBBED
CAP.		DUE DATE	2-2-96	COMPLETED	
LOCATION	F-4-8	QUANTITY	1,000	DATE	1-25-96

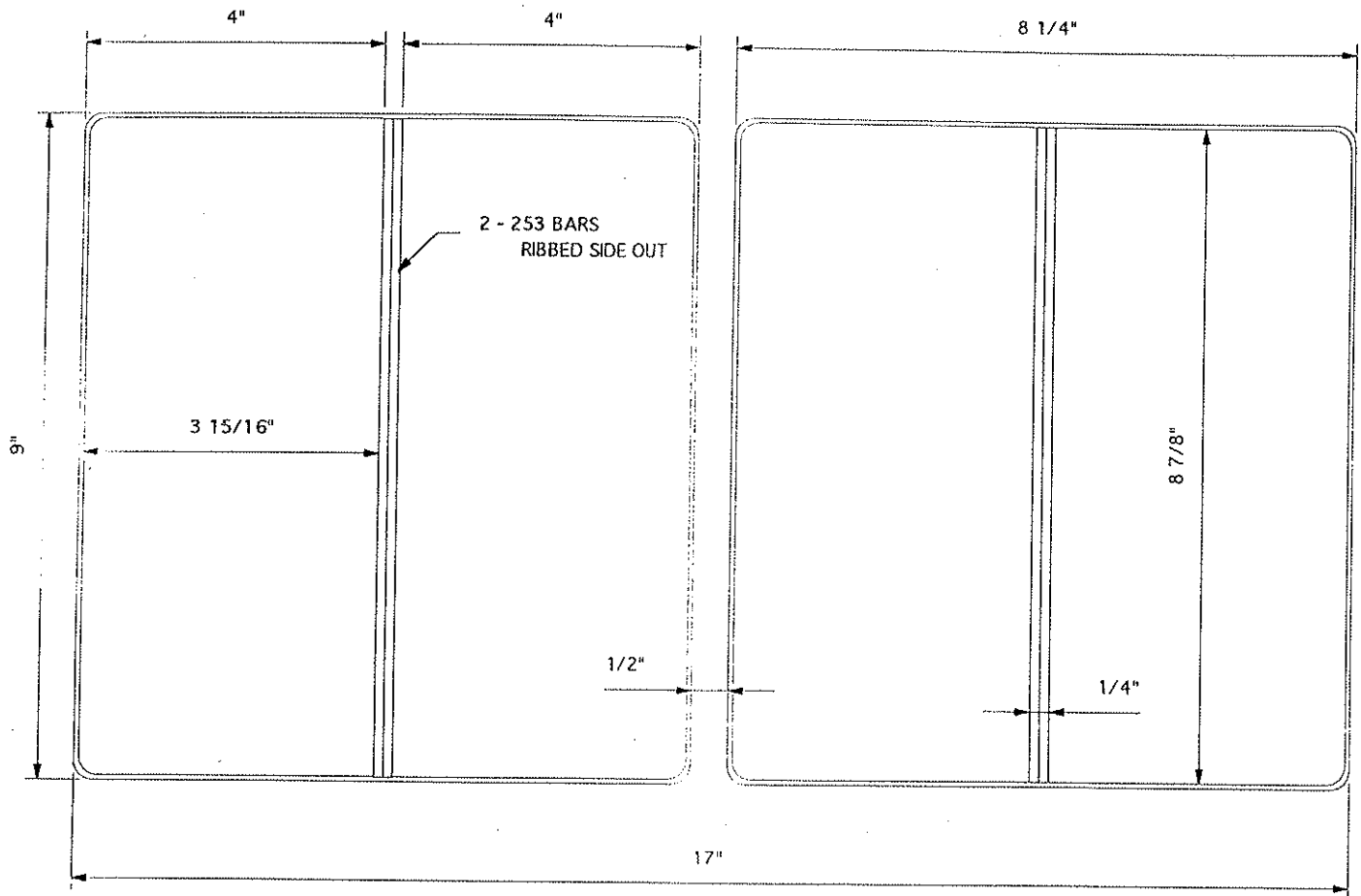

MATERIAL SPECS		GAUGE PCS.		MATERIAL SPECS		GAUGE PCS.	
COVER MAT.	9 3/4 X 17 3/4		1	LINING MAT.			
COVER MAT.				LINING MAT.			
DIE CUT				HORZ. PKT.			
COL	9 1/4 X 17 3/4		1	VERT. PKT.	4 7/8 X 17 3/4		1
LABEL HOLDER				VERT. PKT.	4 3/8 X 17 3/4	CLEAR	1
GUSSET				REINF.			

BOARD SPECS		GAUGE PCS.		BOARD SPECS		GAUGE PCS.	
F.C. BOARD				F.C. BOARD			
B.B. BOARD				B.B. BOARD			
B.C. BOARD				B.C. BOARD			
B.U. STRIP				DIE CUT			
DIE CUT				DIE CUT			

DIE #	5993	METAL		RADIUS	3/8"
ORDER #	983624	CUSTOMER	CONCEPT BINDING CO INC	TEAR SEAL	.014
SHEET SIZE		STYLE CASE	VINYL 2 PC. COVERS	BAR SEAL	1/16
CAP.		DUE DATE	2-1-96	COMPLETED	
LOCATION	F-3-6	QUANTITY	200	DATE	1-19-96

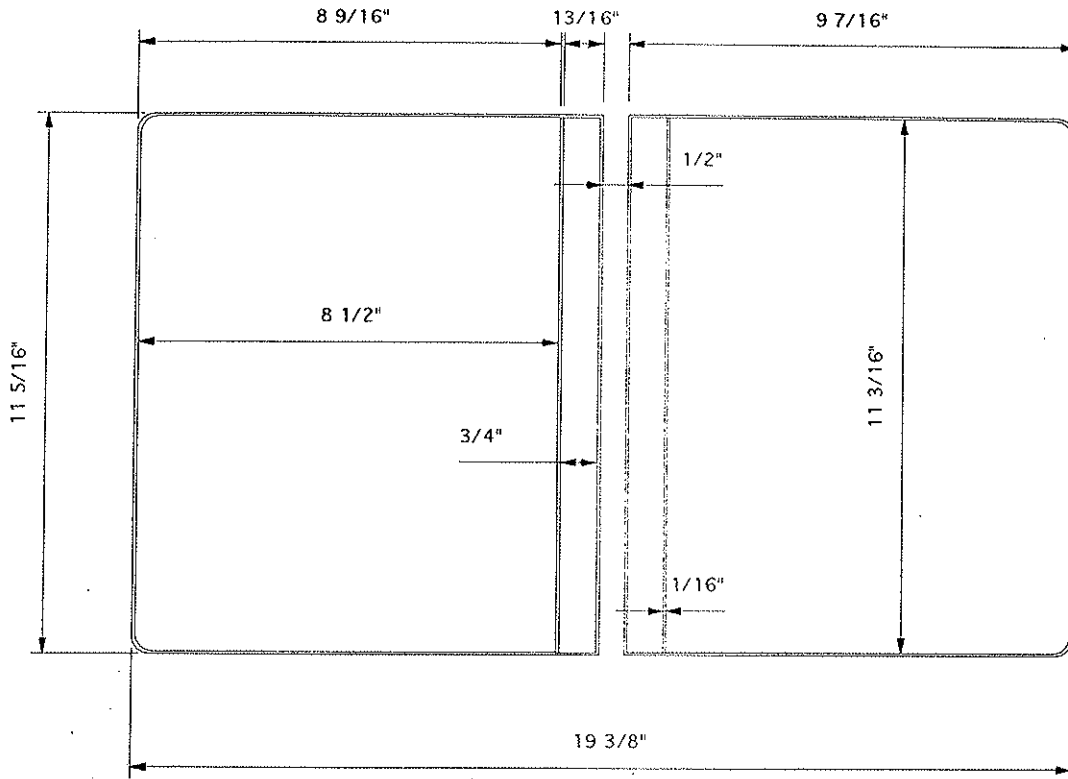

MATERIAL SPECS		GAUGE		MATERIAL SPECS		GAUGE	
COVER MAT.	12 1/8 X 20 1/8		1	LINING MAT.	12 1/8 X 20 1/8		1
COVER MAT.				LINING MAT.			
DIE CUT				HORZ. PKT.			
COL	11 1/2 X 10 3/8		1	VERT. PKT.			
LABEL HOLDER				DIE CUT			
GUSSET				REINF.			

BOARD SPECS		GAUGE		BOARD SPECS		GAUGE	
F.C. BOARD	11 1/8 X 8 7/16	100	1	F.C. BOARD			
B.B. BOARD				B.B. BOARD			
B.C. BOARD	11 1/8 X 8 7/16	100	1	B.C. BOARD			
B.U. STRIP				DIE CUT			
DIE CUT				DIE CUT			

DIE #	6256-A	METAL		RADIUS	1/8"
ORDER #	75722	CUSTOMER	STAR BUILDING SYSTEMS	TEAR SEAL	.014
SHEET SIZE	OA 9 1/4 X 6 13/16	STYLE CASE	VINYL FOLDER W/PKTS	BAR SEAL	178
CAP.		DUE DATE	6-6-97	COMPLETED	
LOCATION	H-4-3	QUANTITY	750	DATE	5-23-97

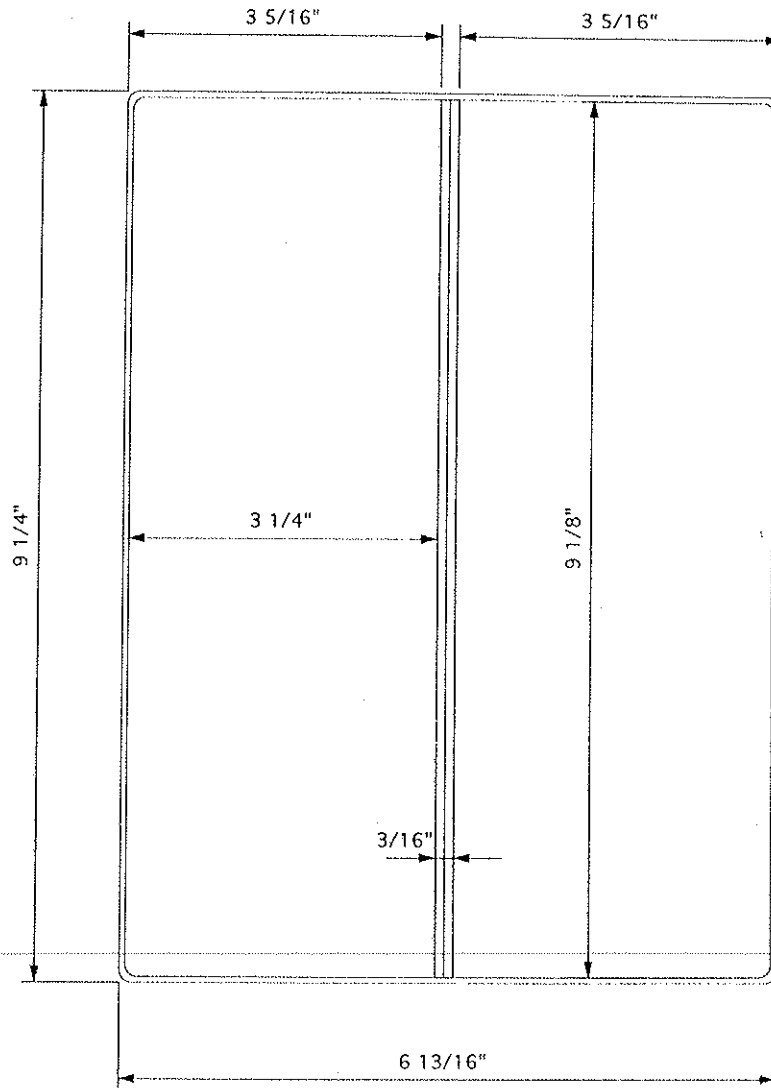

MATERIAL SPECS		GAUGE		PCS.		MATERIAL SPECS		GAUGE	
COVER MAT.	10 X 7 9/16			1		LINING MAT.	10 X 7 9/16		
COVER MAT.						LINING MAT.			
DIE CUT						VERT. PKT.			

BOARD SPECS		GAUGE		PCS.		BOARD SPECS		GAUGE	
F.C. BOARD	9 1/16 X 3 3/16	100		1		F.C. BOARD			
B.B. BOARD						B.B. BOARD			
B.C. BOARD	9 1/16 X 3 3/16	100		1		B.C. BOARD			

DIE #	6461	METAL	NONE	RADIUS	1/4"
ORDER #	77689	CUSTOMER	UNIVERSITY OF TULSA	TEAR SEAL	.010
SHEET SIZE	OA 12 1/4 X 9 5/16	STYLE CASE	VINYL PAD HOLDER	BAR SEAL	102
CAP.	1/2"	DUE DATE	3-27-98	COMPLETED	
LOCATION		QUANTITY	500	DATE	3-20-98

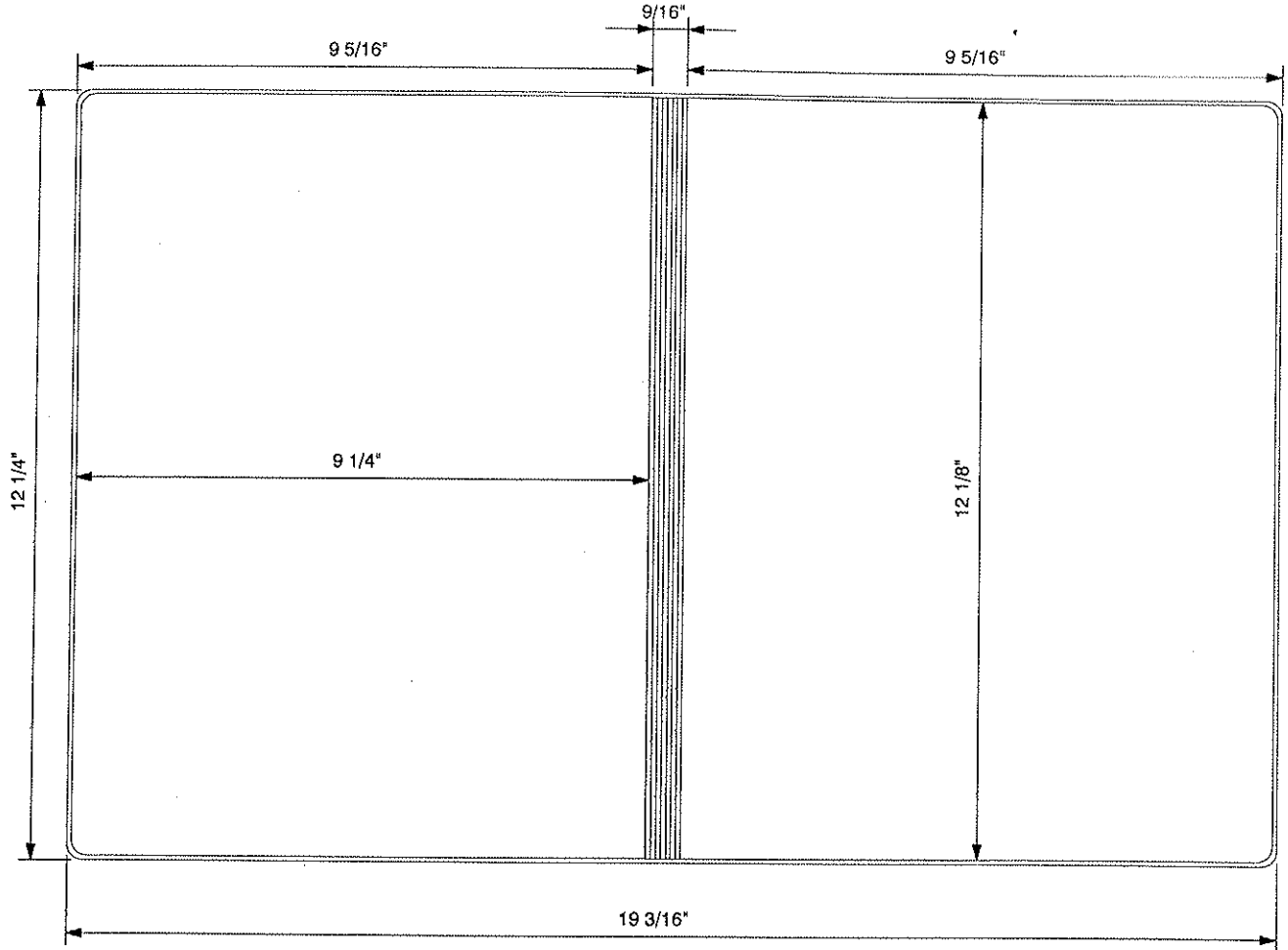

MATERIAL SPECS		GAUGE		PCS.		MATERIAL SPECS		GAUGE		PCS.	
COVER MAT.	13 X 20			1		LINING MAT.	13 X 20			1	
COVER MAT.						LINING MAT.					
DIE CUT						HORZ. PKT.	4 3/8 X 20			1	
COL						VERT. PKT.					
LABEL HOLDER						DIE CUT					
GUSSET						REINF.					

BOARD SPECS		GAUGE		PCS.		BOARD SPECS		GAUGE		PCS.	
F.C. BOARD	12 1/16 X 9 3/16	100		1		F.C. BOARD					
B.B. BOARD						B.B. BOARD					
B.C. BOARD	12 1/16 X 9 3/16	100		1		B.C. BOARD					
FLAP BD.						DIE CUT					
BOARD						DIE CUT					

DIE #	6465	METAL	NONE	RADIUS	1/4"
ORDER #	989542	CUSTOMER	REED TOOL CO	TEAR SEAL	.012
SHEET SIZE	8 1/2 X 14	STYLE CASE	VINYL PAD	BAR SEAL	253 -RIBBED
CAP.	3/8"	DUE DATE	3-31-98	COMPLETED	
LOCATION		QUANTITY	500	DATE	3-23-98

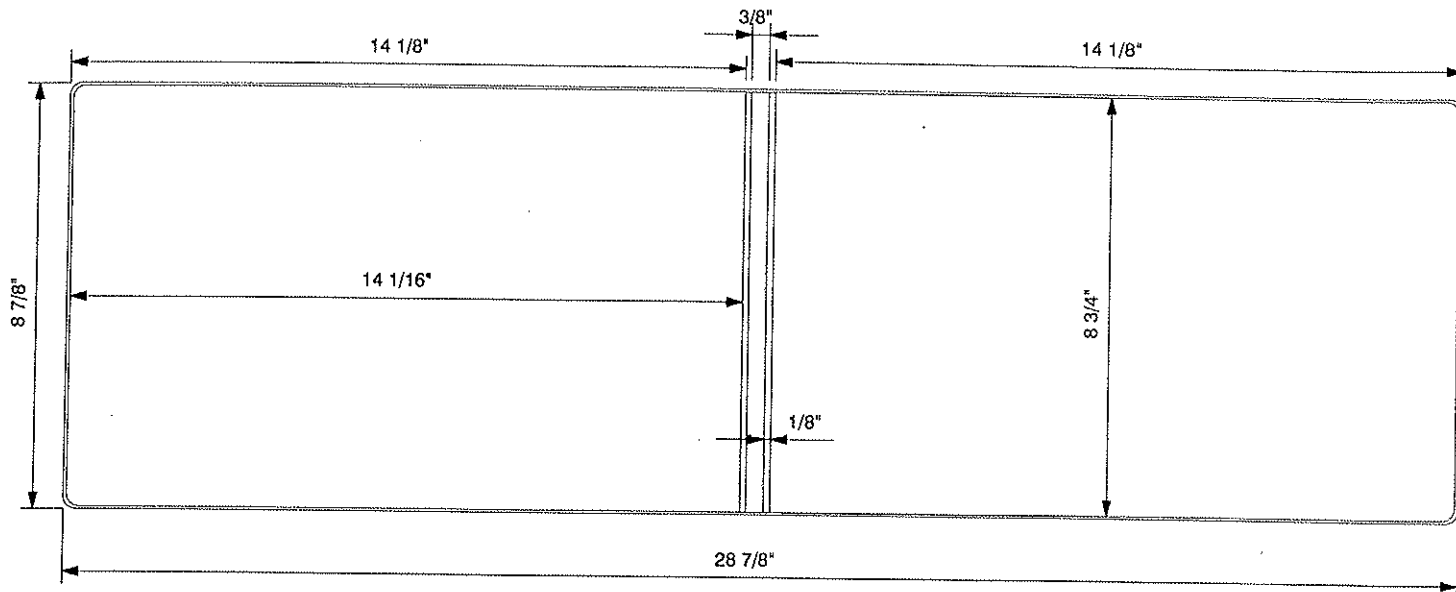

MATERIAL SPECS		GAUGE		MATERIAL SPECS		GAUGE	
COVER MAT.	9 5/8 X 29 5/8		1	LINING MAT.	9 5/8 X 29 5/8		1
COVER MAT.				LINING MAT.			
DIE CUT				HORZ. PKT.			
COL				VERT. PKT.	9 5/8 X 13 7/8		1
LABEL HOLDER				DIE CUT			
GUSSET				REINF.			

BOARD SPECS		GAUGE		BOARD SPECS		GAUGE	
F.C. BOARD				F.C. BOARD	14 X 8 1/16	100	1
B.B. BOARD				B.B. BOARD			
B.C. BOARD				B.C. BOARD	14 X 8 1/16	100	1
FLAP BD.				DIE CUT			
BOARD				DIE CUT			

DIE #	6618	METAL		RADIUS	
ORDER #	193640	CUSTOMER	HAFF-DAUGHTERTY	TEAR SEAL	.012
SHEET SIZE	12 X 9 5/8	STYLE CASE	VINYL FOLDER W/BDS	BAR SEAL	178
CAP.		DUE DATE	1-13-99	COMPLETED	
LOCATION	1-8-8	QUANTITY	500	DATE	1-7-99

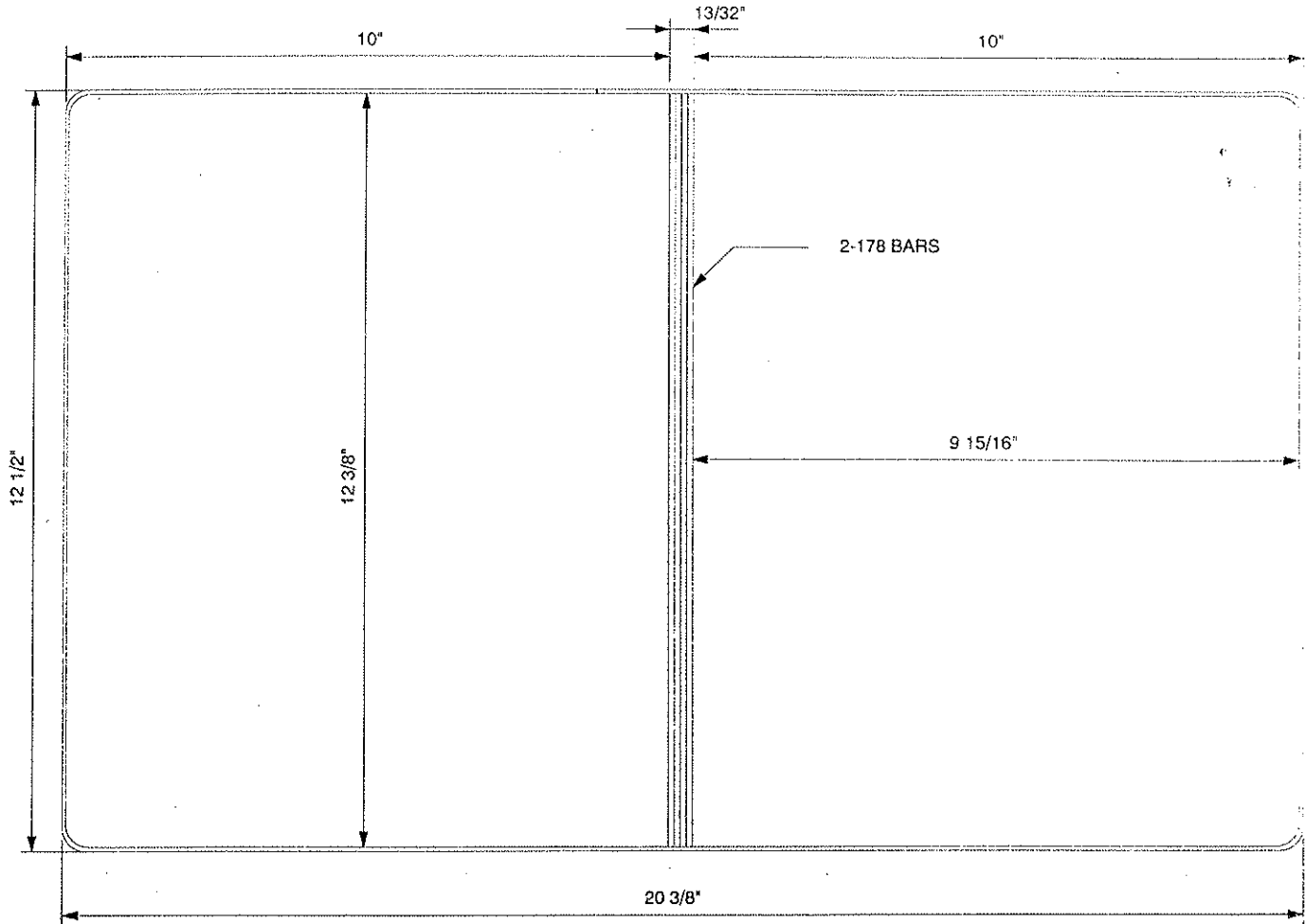

MATERIAL SPECS		GAUGE	PCS.	MATERIAL SPECS		GAUGE	PCS.				
COVER MAT.	13 1/4 X 21 1/8		1	LINING MAT.	13 1/4 X 21 1/8		1				
COVER MAT.				LINING MAT.							
DIE CUT				HORZ. PKT.	5 3/8 X 21 1/8		1				
COL				VERT. PKT.							
LABEL HOLDER				DIE CUT							
GUSSET				REINF.							
BOARD SPECS		5/16" R. CORNERS		GAUGE	PCS.	BOARD SPECS		5/16" R. CORNERS		GAUGE	PCS.
F.C. BOARD	12 5/16 X 9 7/8	120	1	F.C. BOARD							
B.B. BOARD				B.B. BOARD							
B.C. BOARD	12 5/16 X 9 7/8	120	1	B.C. BOARD							
FLAP BD.				DIE CUT							
BOARD				DIE CUT							

DIE #	6900	METAL		RADIUS	3/8"
ORDER #	332013	CUSTOMER	SOUTHWESTERN BELL	TEAR SEAL	.010
SHEET SIZE		STYLE CASE	VINYL FOLDER	BAR SEAL	102
CAP.		DUE DATE	4-25-00	COMPLETED	
LOCATION		QUANTITY	14	DATE	4-20-00

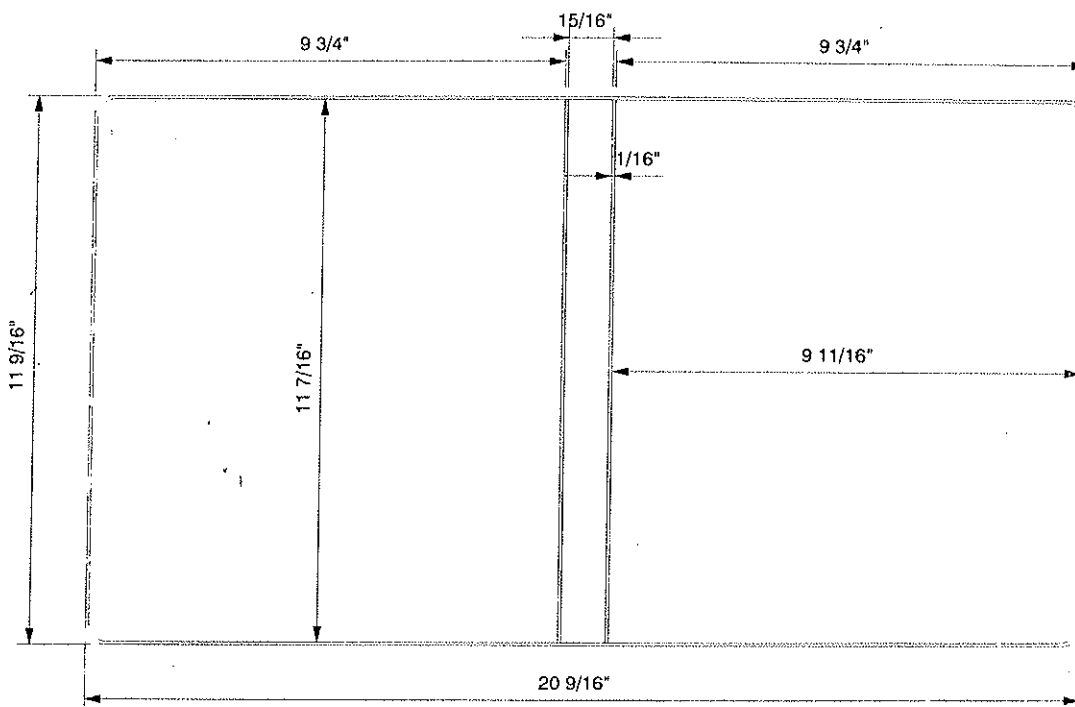

MATERIAL SPECS		GAUGE	PCS.	MATERIAL SPECS		GAUGE	PCS.
COVER MAT.	12 5/16 X 21 5/16		1	LINING MAT.	12 5/16 X 21 5/16		1
COVER MAT.				LINING MAT.			
DIE CUT				HORZ. PKT.			
COL				VERT. PKT.			
LABEL HOLDER				DIE CUT			
GUSSET				REINF.			

BOARD SPECS		GAUGE	PCS.	BOARD SPECS		GAUGE	PCS.
F.C. BOARD	11 3/8 X 9 5/8	22	1	F.C. BOARD			
B.B. BOARD				B.B. BOARD			
B.C. BOARD	11 3/8 X 9 5/8	22	1	B.C. BOARD			
FLAP BD.				DIE CUT			
BOARD -				DIE CUT			

DIE #	6984-A	METAL		RADIUS	3/8"
ORDER #	368850	CUSTOMER	AURORA CASKET CO.	TEAR SEAL	.010
SHEET SIZE		STYLE CASE	VINYL SWATCH BOOK	BAR SEAL	48-3
CAP.		DUE DATE	10-4-00	COMPLETED	
LOCATION		QUANTITY	100	DATE	9-25-00

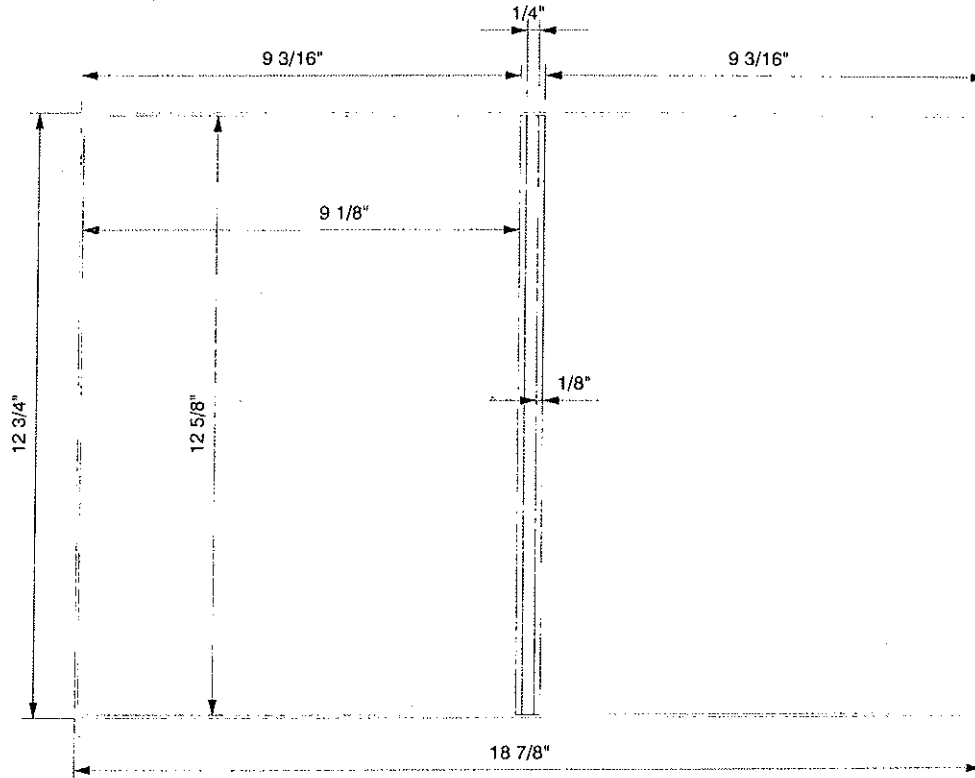

MATERIAL SPECS		GAUGE	PCS.	MATERIAL SPECS		GAUGE	PCS.
COVER MAT.	13 1/2 X 19 5/8		1	LINING MAT.	13 1/2 X 19 5/8		1
COVER MAT.				LINING MAT.			
DIE CUT				HORZ. PKT.			
COL				VERT. PKT.			
LABEL HOLDER				DIE CUT			
GUSSET				REINF.			
BOARD SPECS		5/16" R. CORNERS		BOARD SPECS		5/16" R. CORNERS	
F.C. BOARD	12 9/16 X 9 1/16	100	1	F.C. BOARD			
B.B. BOARD				B.B. BOARD			
B.C. BOARD	12 9/16 X 9 1/16	100	1	B.C. BOARD			
FLAP BD.				DIE CUT			
BOARD				DIE CUT			

DIE #	7206-A-B	METAL		RADIUS	3/8"
ORDER #	474783	CUSTOMER	MUSIC CITY OPTICAL	TEAR SEAL	.014
SHEET SIZE		STYLE CASE	VINYL CD BINDER	BAR SEAL	253
CAP.		DUE DATE	1-31-02	COMPLETED	
LOCATION		QUANTITY	1000	DATE	1-23-02

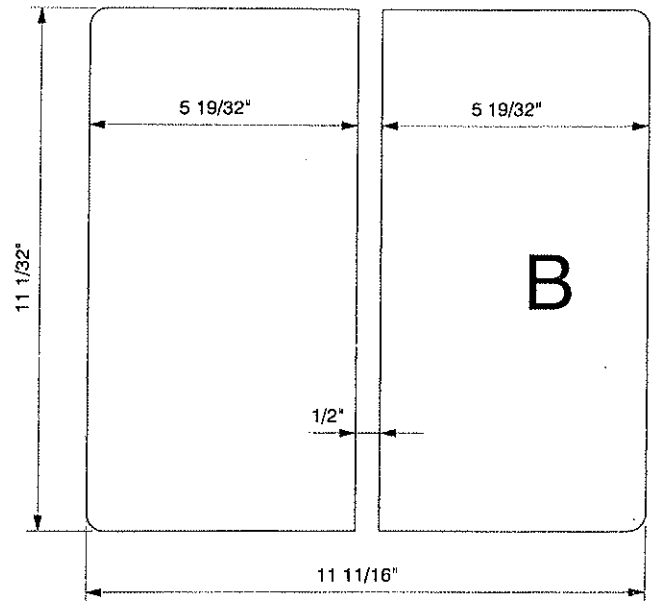
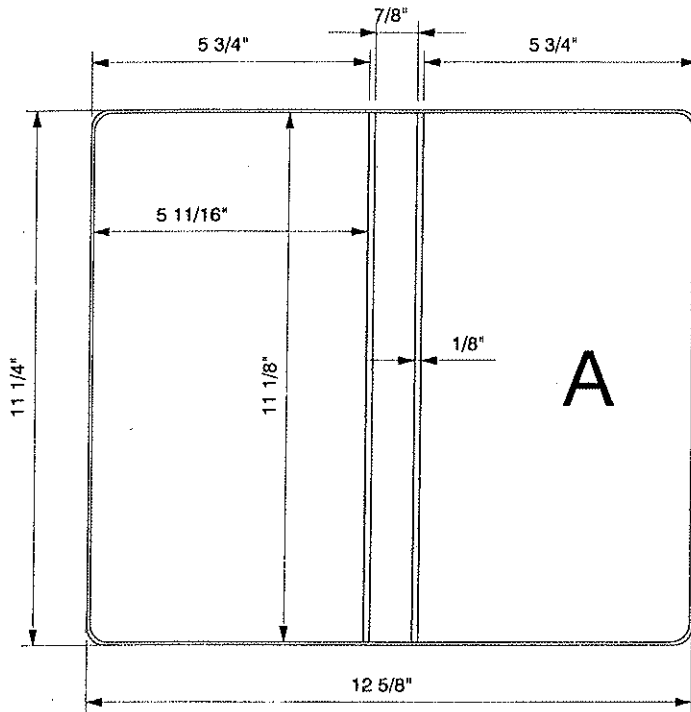

MATERIAL SPECS		GAUGE	PCS.	MATERIAL SPECS		GAUGE	PCS.
COVER MAT.	12 1/4 X 13 5/8		1	LINING MAT.	12 X 13 3/8		1
COVER MAT.				LINING MAT.			
DIE CUT				HORZ. PKT.	4 3/8 X 6 1/4		1
COL				VERT. PKT.			
LABEL HOLDER				DIE CUT			
GUSSET				REINF.			
BOARD SPECS		GAUGE	PCS.	BOARD SPECS		GAUGE	PCS.
5/16" R. CORNERS				5/16" R. CORNERS			
F.C. BOARD				F.C. BOARD			
B.B. BOARD				B.B. BOARD			
B.C. BOARD				B.C. BOARD	PADDED BOARD DIECUT 7206-B		
FLAP BD.				DIE CUT	12 X 12 5/8	100	1
BOARD				DIE CUT			

DIE #	7212	METAL	NONE	RADIUS	3/8"
ORDER #	476578	CUSTOMER	BASSETT PRINTING	TEAR SEAL	.012
SHEET SIZE	11 3/4 X 8 3/4	STYLE CASE	VINYL FOLDER	BAR SEAL	48-4
CAP.	5/8"	DUE DATE	2-8-02	COMPLETED	
LOCATION		QUANTITY	500	DATE	1-30-02

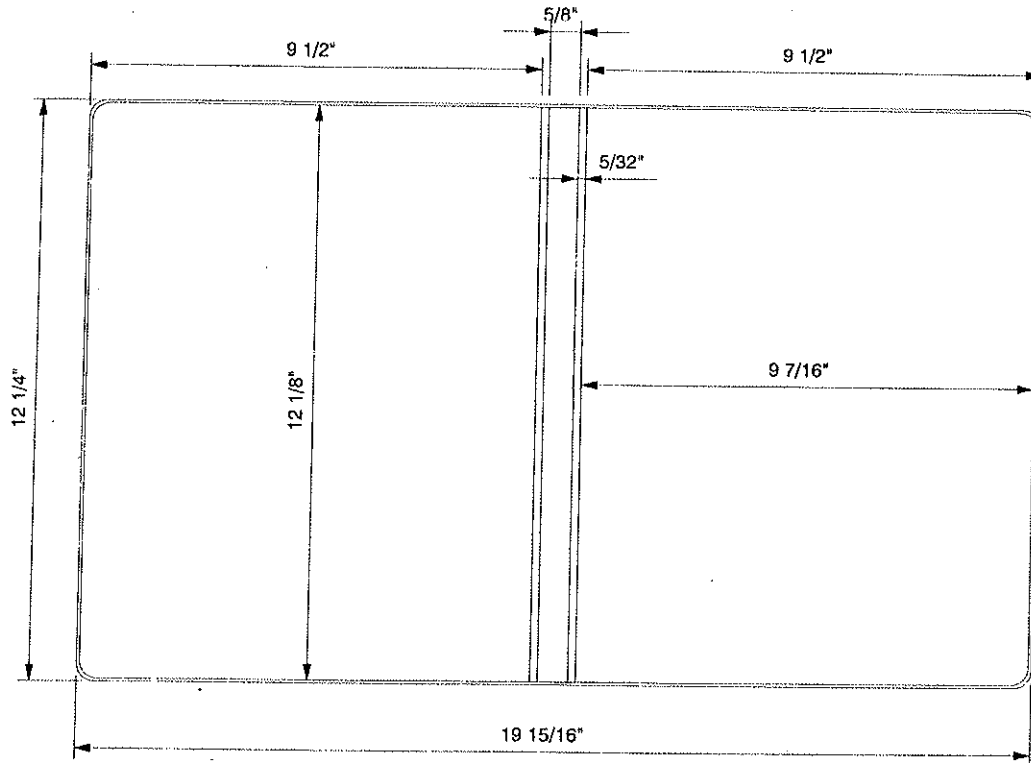

MATERIAL SPECS		GAUGE	PCS.	MATERIAL SPECS		GAUGE	PCS.
COVER MAT.	13 X 20 3/4		1	LINING MAT.	13 X 20 3/4		1
COVER MAT.				LINING MAT.			
DIE CUT				HORZ. PKT.			
COL	12 3/8 X 20 3/4		1	VERT. PKT.	13 X 7 3/8		2
LABEL HOLDER				DIE CUT			
GUSSET				REINF.			
BOARD SPECS		GAUGE	PCS.	BOARD SPECS		GAUGE	PCS.
5/16" R. CORNERS				5/16" R. CORNERS			
F.C. BOARD	12 1/16 X 9 3/8	100	1	F.C. BOARD			
B.B. BOARD	12 1/16 X 17/32	100	1	B.B. BOARD			
B.C. BOARD	12 1/16 X 9 3/8	100	1	B.C. BOARD			
FLAP BD.				DIE CUT			
BOARD				DIE CUT			

DIE #	7418	METAL		RADIUS	3/8"
ORDER #	550096	CUSTOMER	EMBASSY SUITES	TEAR SEAL	
SHEET SIZE	6 X 5	STYLE CASE	VINYL PAD	BAR SEAL	
CAP.		DUE DATE	4-14-03	COMPLETED	
LOCATION		QUANTITY	1000	DATE	4-10-03

NELL DIE

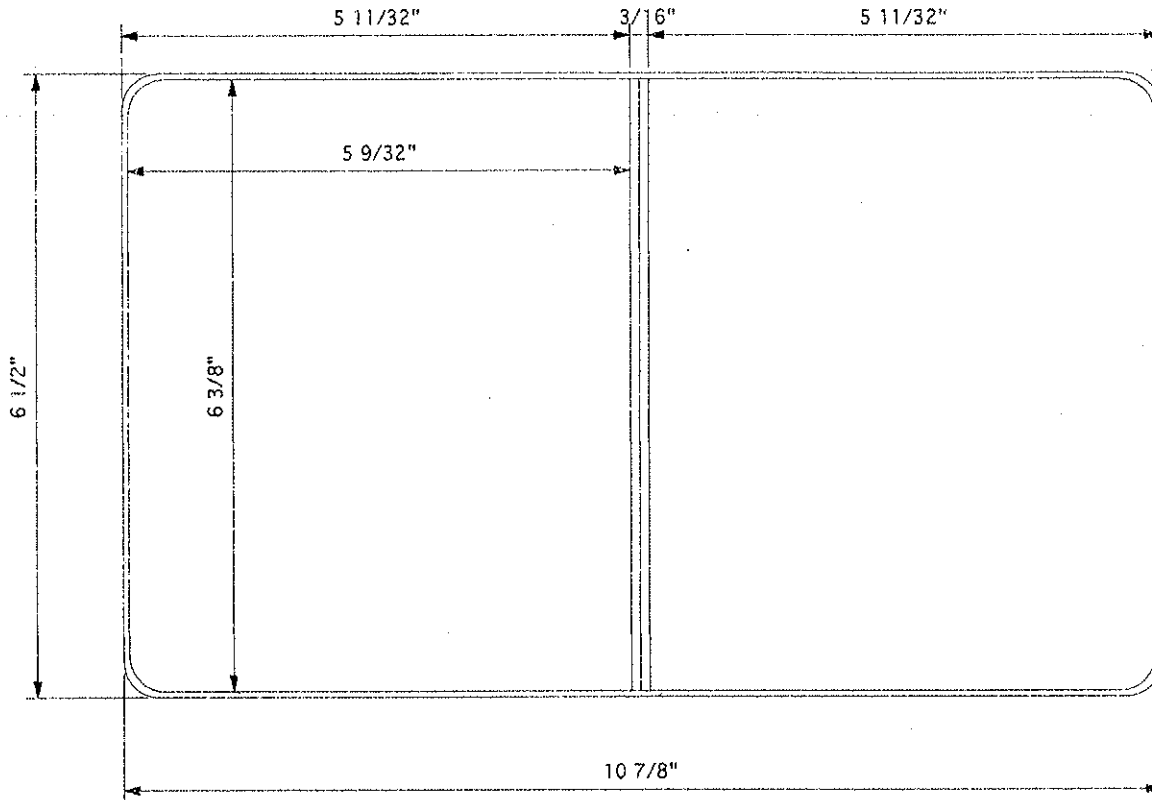

MATERIAL SPECS		GAUGE	PCS.	MATERIAL SPECS	GAUGE	PCS.
COVER MAT.	7 1/4 X 11 5/8		1	LINING MAT.	7 1/4 X 11 5/8	1
COVER MAT.				LINING MAT.		
DIE CUT				HORZ. PKT.		
COL				VERT. PKT.	7 1/4 X 4 3/8	2
LABEL HOLDER				DIE CUT		
GUSSET				REINF.		
BOARD SPECS		GAUGE	PCS.	BOARD SPECS	GAUGE	PCS.
F.C. BOARD	6 5/16 X 5 7/32	100	1	F.C. BOARD		
B.B. BOARD				B.B. BOARD		
B.C. BOARD	6 5/16 X 5 7/32	100	1	B.C. BOARD		
FLAP BD.				DIE CUT		
BOARD				DIE CUT		

DIE #	7509 A-B-C	METAL	NONE	RADIUS	3/8"
ORDER #	570695	CUSTOMER	ALLEN TATE CO.	TEAR SEAL	BLIND + .008
SHEET SIZE	11 X 9	STYLE CASE	VINYL FOLDER	BAR SEAL	FLAT
CAP.	1"	DUE DATE	8-28-03	COMPLETED	
LOCATION		QUANTITY	500	DATE	8-11-03

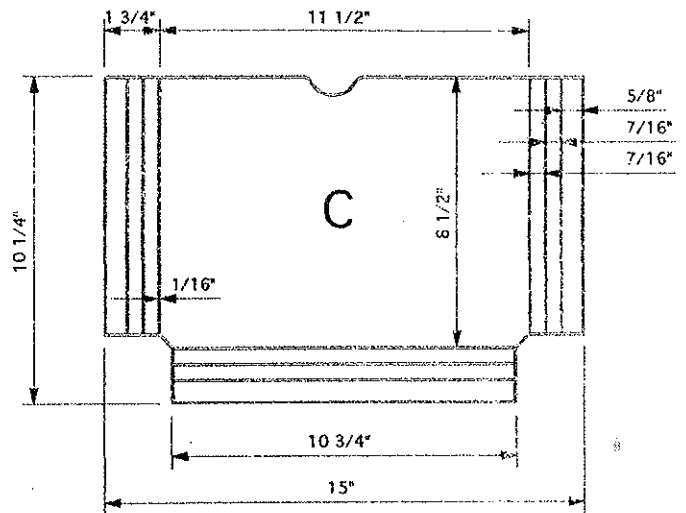
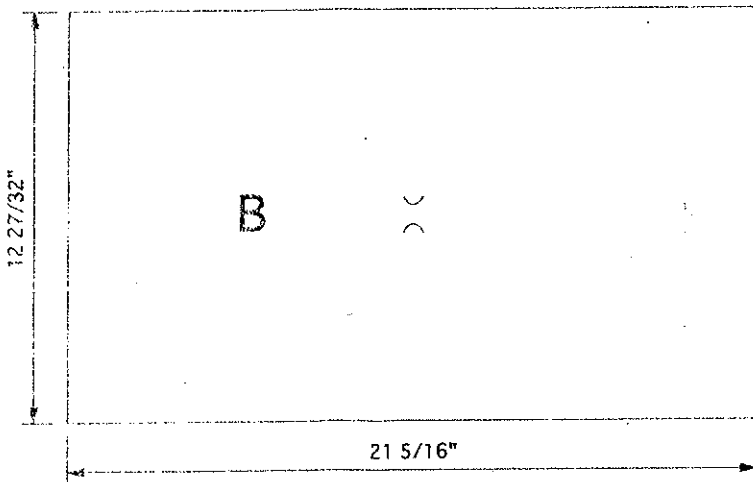
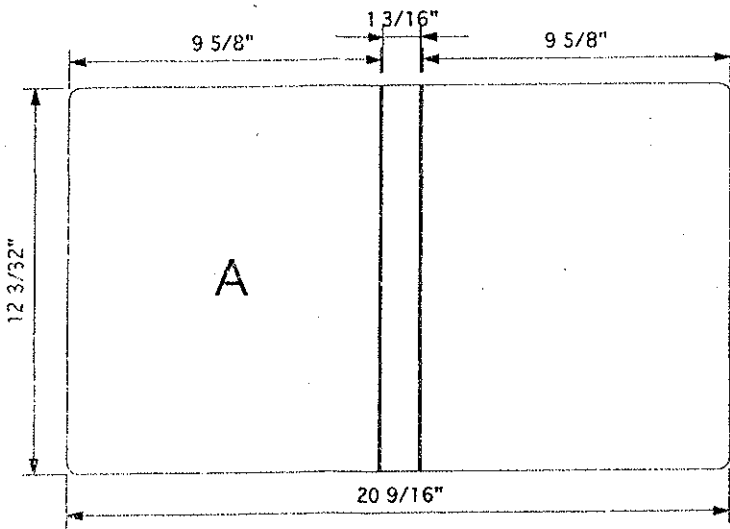

MATERIAL SPECS		GAUGE	PCS.	MATERIAL SPECS		GAUGE	PCS.
COVER MAT.	12 13/16 X 21 5/16	A	1	LINING MAT.	13 13/16 X 22 5/16	B	1
COVER MAT.				LINING MAT.			
DIE CUT				HORZ. PKT.			
COL				VERT. PKT.	11 19/32 X 10 1/16	A	1
LABEL HOLDER				DIE CUT			
GUSSET	11 X 15 3/4	C	1	REINF.			
BOARD SPECS	5/16" R. CORNERS	GAUGE	PCS.	BOARD SPECS	5/16" R. CORNERS	GAUGE	PCS.
F.C. BOARD	12 1/32 X 9 9/16	A	100	F.C. BOARD			
B.B. BOARD				B.B. BOARD			
B.C. BOARD	12 1/32 X 9 9/16	A	100	B.C. BOARD			
FLAP BD.				DIE CUT			
BOARD				DIE CUT			

DIE #	7513	METAL	RADIUS	1/8"	
ORDER #	572682	CUSTOMER	GBC LINCOLNSHIRE	TEAR SEAL	.014
SHEET SIZE	9 3/16 X 7 5/16 OA	STYLE CASE	VINYL RIBBED FOLDER	BAR SEAL	178 RIB
CAP.	19/32"	DUE DATE	8-29-03	COMPLETED	
LOCATION		QUANTITY	5000	DATE	8-18-03

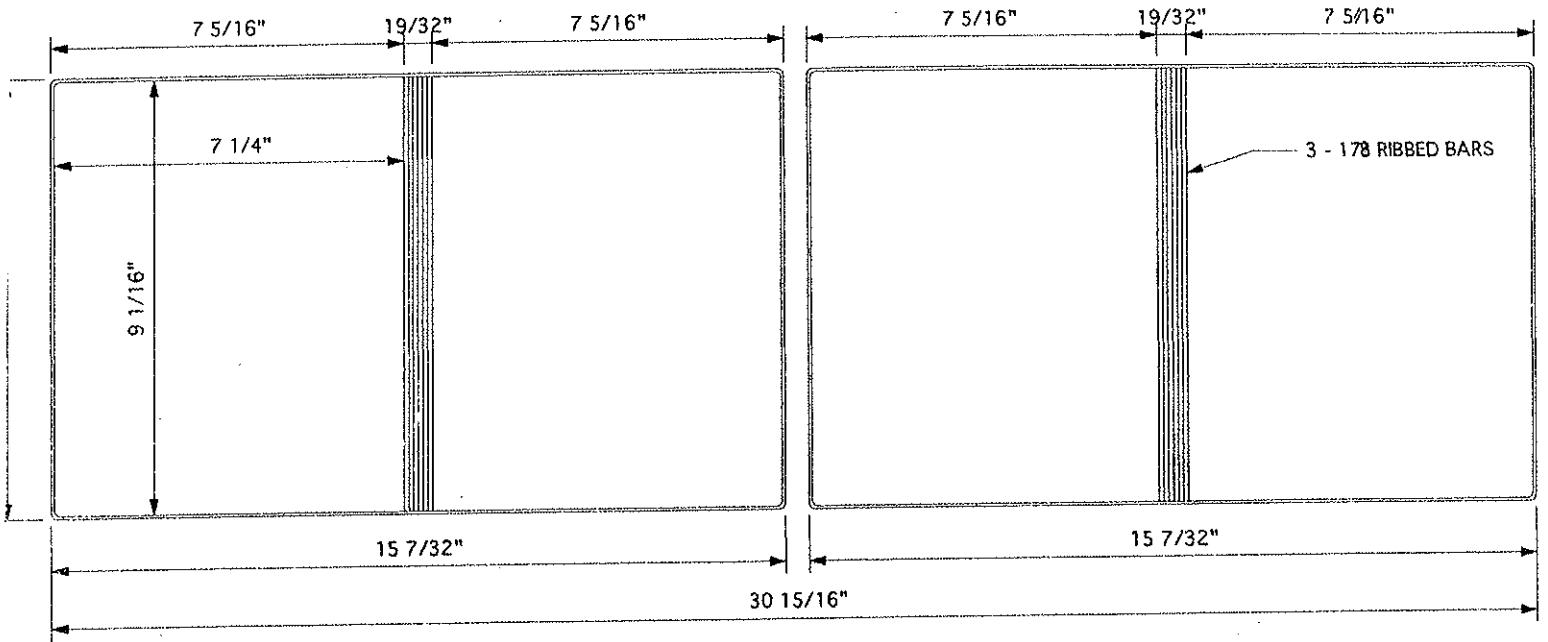

2 OUT

MATERIAL SPECS		GAUGE	PCS.	MATERIAL SPECS		GAUGE	PCS.
COVER MAT.	10 X 31 3/4	V285	1	LINING MAT.	10 X 31 3/4	V285	1
COVER MAT.				LINING MAT.			
DIE CUT				VERT. PKT.	10 X 5 3/8	CLEAR	2
COL	10 X 7 9/16	CLEAR	2	VERT. PKT.	10 X 10 1/2	CLEAR	1
LABEL HOLDER				DIE CUT			
GUSSET				REINF.			
BOARD SPECS		GAUGE	PCS.	BOARD SPECS		GAUGE	PCS.
F.C. BOARD	9 X 7 3/16	100	4	F.C. BOARD	5/16" R. CORNERS		
B.B. BOARD				B.B. BOARD			
B.C. BOARD				B.C. BOARD			
FLAP BD.				DIE CUT			
BOARD				DIE CUT			

DIE #	7517	METAL	RADIUS	1/8"	
ORDER #	573061	CUSTOMER	EMBASSY SUITES	TEAR SEAL	BLIND
SHEET SIZE	7 7/8 X 5 1/2	STYLE CASE	VINYL PAD	BAR SEAL	102
CAP.		DUE DATE	8-30-03	COMPLETED	
LOCATION		QUANTITY	100	DATE	8-21-03

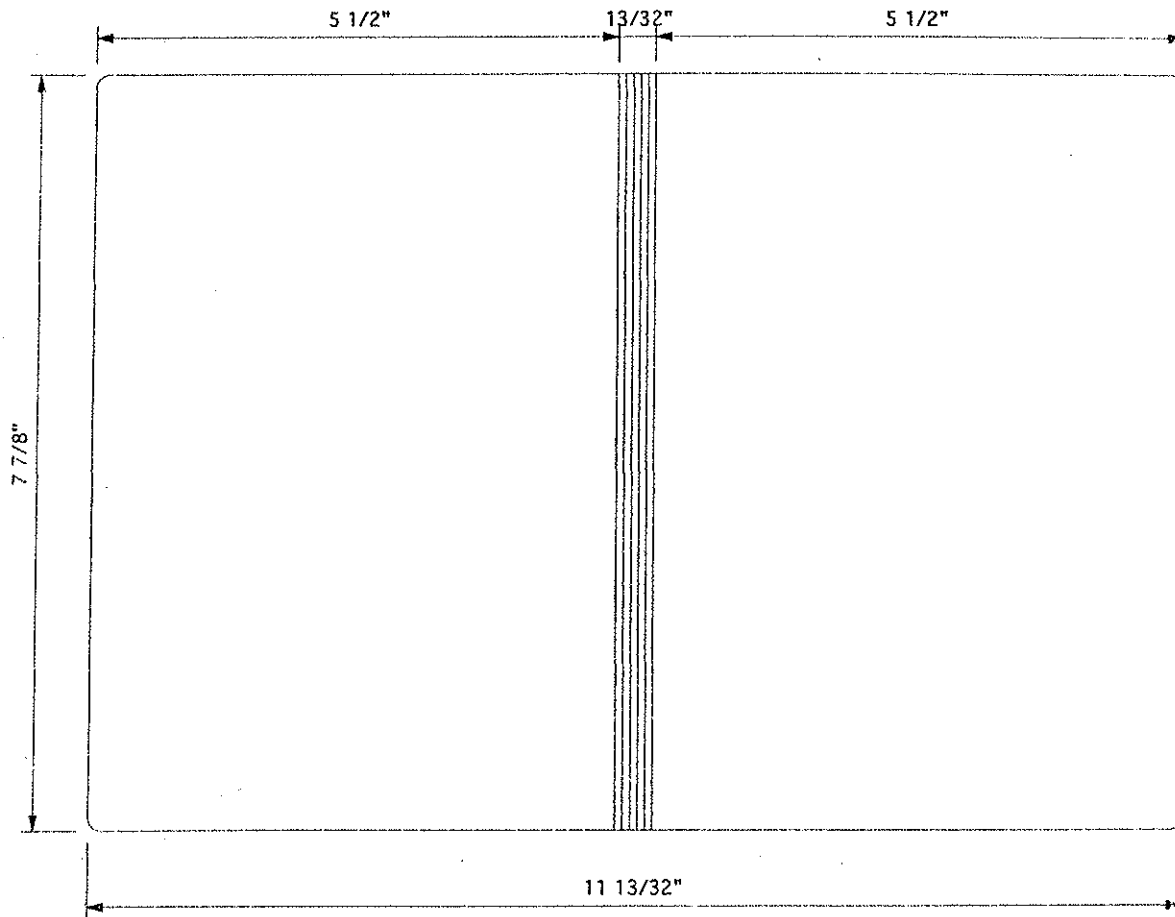

MATERIAL SPECS		GAUGE	PCS.	MATERIAL SPECS		GAUGE	PCS.
COVER MAT.	8 7/8 X 12 3/8		1	LINING MAT.	8 5/8 X 12 1/8		1
COVER MAT.				LINING MAT.			
DIE CUT				HORZ. PKT.			
COL				VERT. PKT.			
LABEL HOLDER				DIE CUT			
GUSSET				REINF.			
BOARD SPECS		GAUGE	PCS.	BOARD SPECS		GAUGE	PCS.
F.C. BOARD	7 25/32 X 5 13/32		100	F.C. BOARD	5/16" R. CORNERS		
B.B. BOARD	SQ. CORNERS ON ALL BOARDS			B.B. BOARD			
B.C. BOARD	7 25/32 X 5 13/32		100	B.C. BOARD			
FLAP BD.				DIE CUT			
BOARD				DIE CUT			

DIE #	8013	METAL		RADIUS	1/8"
ORDER #	702491	CUSTOMER	GBS CORPORATION	TEAR SEAL	.014
SHEET SIZE		STYLE CASE	VINYL FOLDER	BAR SEAL	
CAP.		DUE DATE	11-11-05	COMPLETED	
LOCATION		QUANTITY	50	DATE	10-31-05

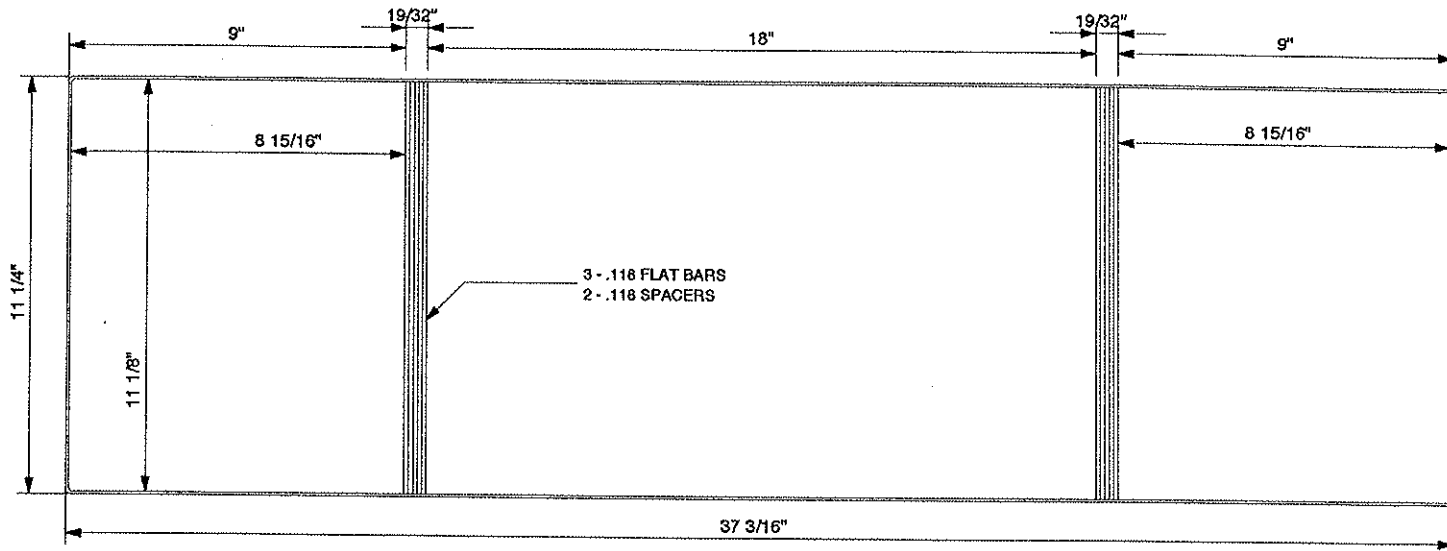

MATERIAL SPECS		GAUGE	PCS.	MATERIAL SPECS	GAUGE	PCS.
COVER MAT.	12 1/4 X 38 1/4		1	LINING MAT.	12 X 38	1
COVER MAT.				LINING MAT.		
PEN LOOP	2 X 2		1	HORZ. PKT.	4 3/8 X 38	1
COL.				VERT. PKT.		
LABEL HOLDER				DIE CUT		
GUSSET				REINF.		

BOARD SPECS		5/16" R. CORNERS	GAUGE	PCS.	BOARD SPECS	5/16" R. CORNERS	GAUGE	PCS.
F.C. BOARD	11 1/32 X 8 27/32		119	1	F.C. BOARD			
B.B. BOARD	11 1/32 X 17 29/32		119	1	B.B. BOARD			
B.C. BOARD	11 1/32 X 8 27/32		119	1	B.C. BOARD			
FLAP BD.					DIE CUT			
BOARD					DIE CUT			

DIE #	8141	METAL	NONE	RADIUS	3/8"
ORDER #	733693	CUSTOMER	BANG STUDIOS	TEAR SEAL	.014
SHEET SIZE	11.5 X 9.5 OA	STYLE CASE	VINYL FOLDER	BAR SEAL	253
CAP.	1/2"	DUE DATE	5-31-06	COMPLETED	
LOCATION		QUANTITY	100	DATE	5-13-06

***. WARNING DRAWING NOT ACTUAL SIZE ***

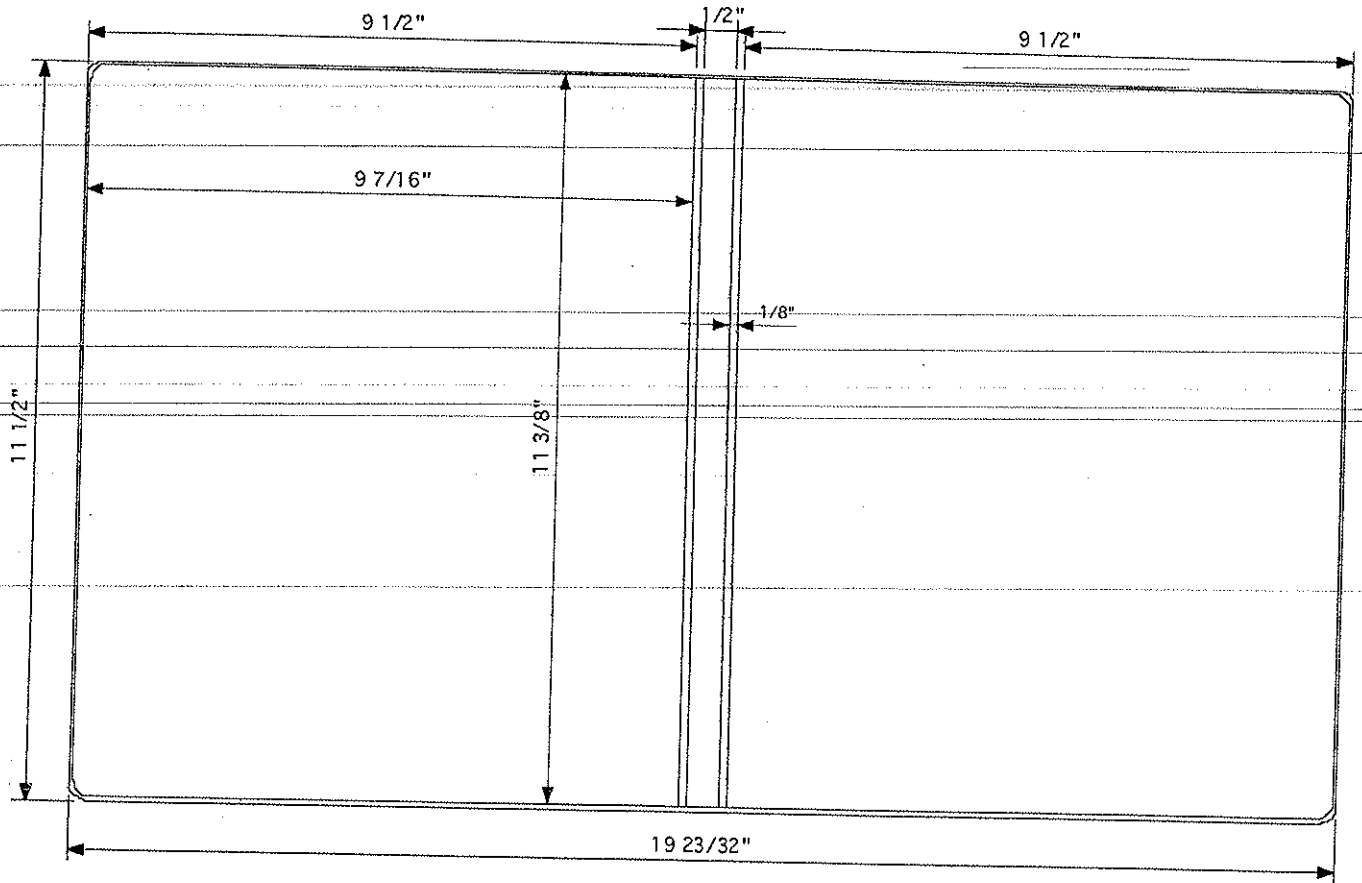

MATERIAL SPECS

MATERIAL SPECS		GAUGE	PCS.	MATERIAL SPECS		GAUGE	PCS.
COVER MAT.	12 1/4 X 20 1/2		1	LINING MAT.	12 1/4 X 20 1/2		1
COVER MAT.				LINING MAT.			
DIE CUT				HORZ. PKT.	4 7/8 X 10		1
COL	11 3/4 X 1 3/4		1	VERT. PKT.	12 1/4 X 8 3/8		1
LABEL HOLDER				DIE CUT			
GUSSET				REINF.			

BOARD SPECS

5/16" R. CORNERS

GAUGE PCS.

BOARD SPECS

5/16" R. CORNERS

GAUGE PCS.

F.C. BOARD	11 5/16 X 9 3/8	100	1	F.C. BOARD			
B.B. BOARD	11 5/16 X 13/32	60	1	B.B. BOARD			
B.C. BOARD	11 5/16 X 9 3/8	100	1	B.C. BOARD			
FLAP BD.				DIE CUT			
BOARD	11 1/4 X 3/8	35	1	DIE CUT			

DIE #	8418	METAL	NONE	RADIUS	1/8"
ORDER #	817889	CUSTOMER	TINKER BUSINESS FORMS	TEAR SEAL	.012
SHEET SIZE	6 X 3 1/2	STYLE CASE	VINYL FOLDER	BAR SEAL	SEE SAMPLE
CAP.	3/4"	DUE DATE	12-17-07	COMPLETED	
LOCATION		QUANTITY	1500	DATE	11-27-07

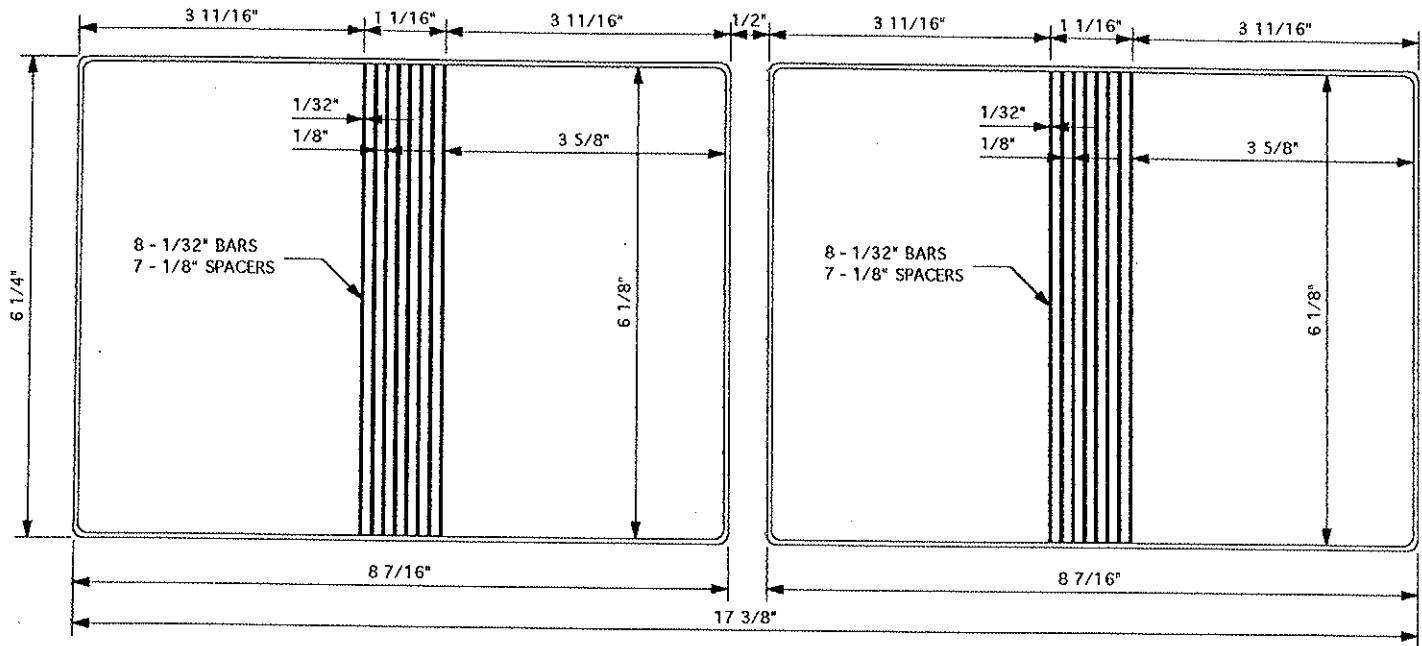

*** NOTE : ALL SPECS BELOW ARE 2 OUT ***

MATERIAL SPECS		GAUGE	PCS.	MATERIAL SPECS		GAUGE	PCS.
COVER MAT.	7 X 18 1/8	WHITE	1	LINING MAT.	7 X 18 1/8	WHITE	1
COVER MAT.				VERT. PKT.	7 X 3 3/8	WHITE	2
DIE CUT				VERT. PKT.	7 X 6 1/2	WHITE	1
SOL Pict.	7 X 4 1/8	Clear	2	VERT. PKT.	5 3/8 X 3 3/8	CLEAR	2
LABEL HOLDER				VERT. PKT.	5 3/8 X 6 1/2	CLEAR	1
GUSSET				REINF.			

BOARD SPECS		GAUGE	PCS.	BOARD SPECS		GAUGE	PCS.
	5/16" R. CORNERS				5/16" R. CORNERS		
F.C. BOARD	6 1/16 X 3 9/16	100	4	F.C. BOARD			
B.B. BOARD				B.B. BOARD			
B.C. BOARD				B.C. BOARD			
FLAP BD.				DIE CUT			
BOARD				DIE CUT			

DIE #	8601	METAL		RADIUS	1/4"
ORDER #	868547	CUSTOMER	EMBASSY SUITES	TEAR SEAL	.008
SHEET SIZE	8 1/8 X 5 1/8	STYLE CASE	VINYL FOLDER	BAR SEAL	178
CAP.		DUE DATE	11-4-08	COMPLETED	
LOCATION		QUANTITY	100	DATE	10-21-08

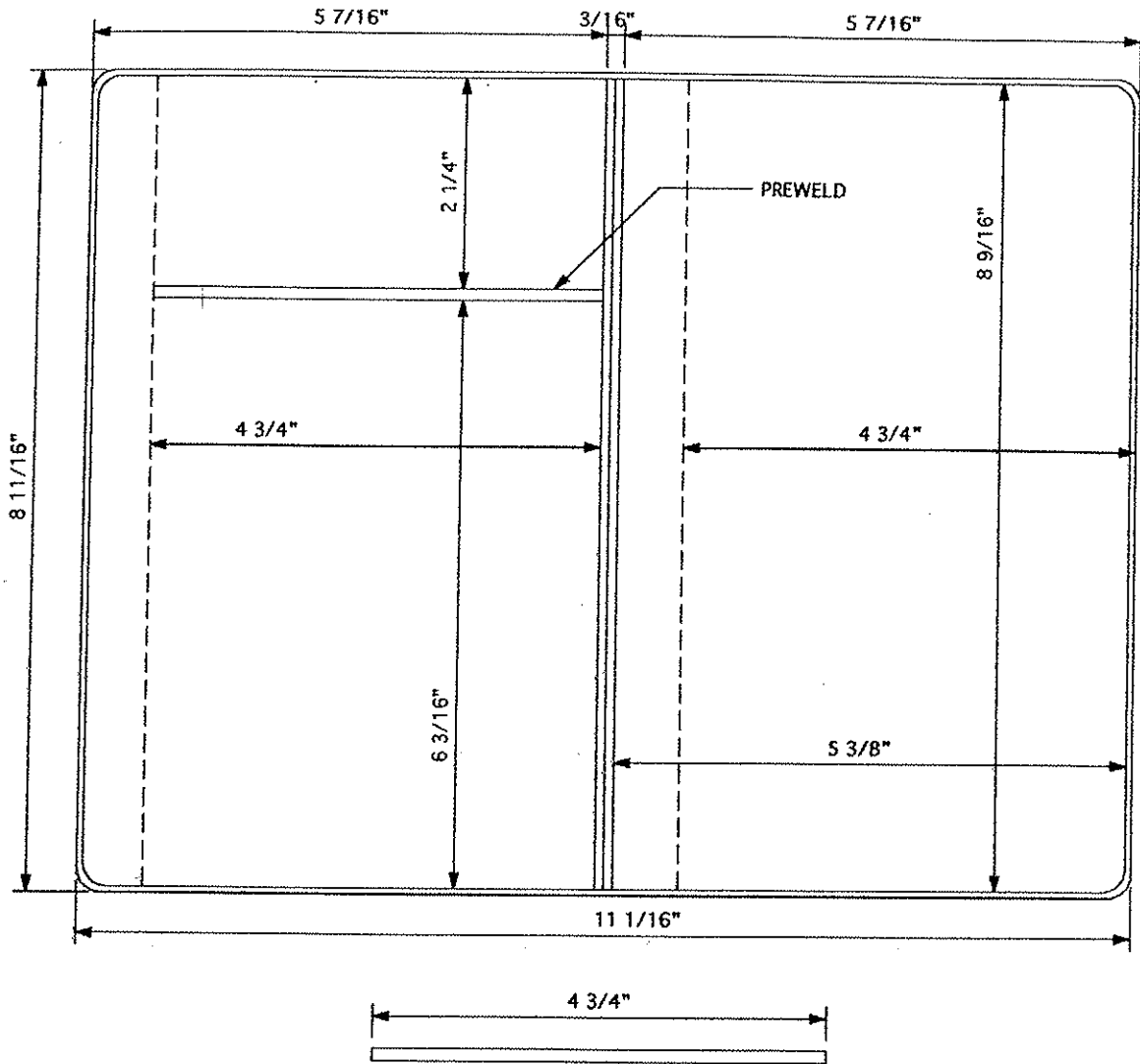

MATERIAL SPECS		GAUGE	PCS.	MATERIAL SPECS		GAUGE	PCS.
COVER MAT.	9 7/16 X 11 13/16		1	LINING MAT.	9 7/16 X 11 13/16		1
COVER MAT.				LINING MAT.			
DIE CUT				HORZ. PKT.	9 7/16 X 5 1/8		1
COL				VERT. PKT.	9 7/16 X 4 7/8		1
LABEL HOLDER				DIE CUT			
GUSSET				REINF.			
BOARD SPECS		GAUGE	PCS.	BOARD SPECS		GAUGE	PCS.
F.C. BOARD	8 1/2 X 5 9/32		100	F.C. BOARD	5/16" R. CORNERS		2
B.B. BOARD				B.B. BOARD			
B.C. BOARD				B.C. BOARD			
FLAP BD.				DIE CUT			
BOARD				DIE CUT			