

Product Code

Style Case Folder

Overall as Sample 3/4 Cap.
Sheet Size 9 X 5 3/4

Die No. 7377

Order No. 37867-9

Plate

Customer

The Performance Group

Metal
Total Vinyl .045
Quantity 2000
Date 5-24-79
Type Corners Rd
Radius 3/32
Completed

	Gauge	Thick
Tear Seal	.012	3/32
Bar Seal	.253	1/8
Bar Seal	.102	3/32

	No. of Feet
Tear Seal	4 1/2
Bar Seal	1 1/2
Bar Seal	

0.984 = 1 pc. of 60% head

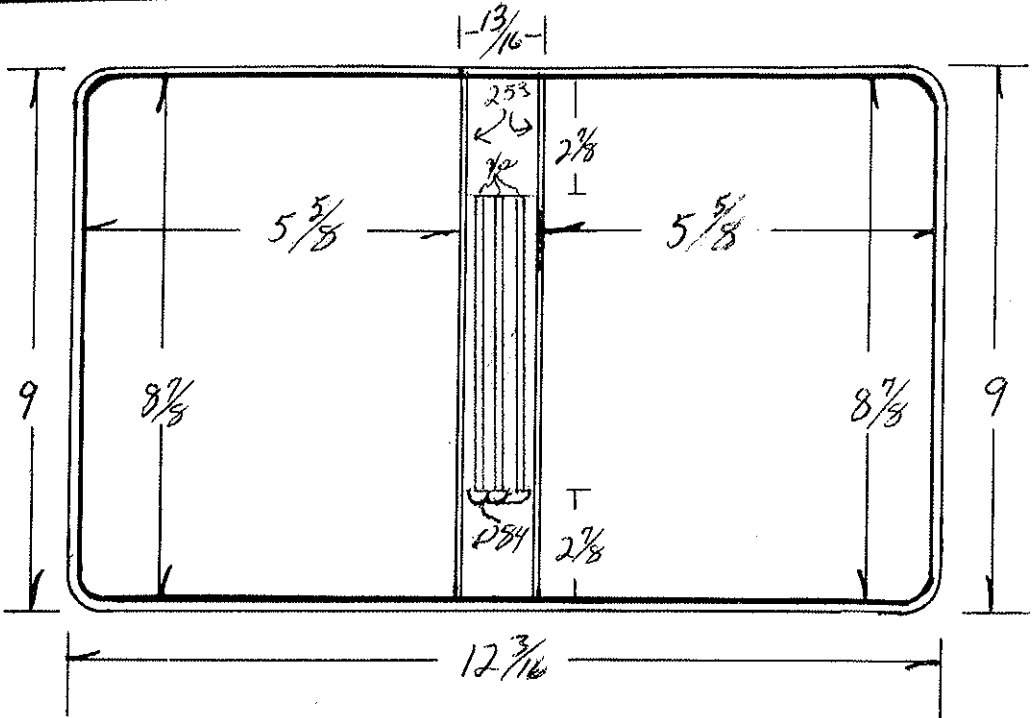

Code	Ga.	# PCS	Cutting Specs		Code	Ga.	# Pcs.	Cutting Specs	
			Size	Out				Size	Out
Cover Mat.		1	9 5/8 X 12 13/16		Lining Mat.		1	9 5/8 X 12 13/16	
Cover Mat.			X		Lining Mat.			X	
Vert. Pckt.		1	9 5/8 X 5 15/16		Horz. Pckt.		1	3 5/16 X 6 1/8	
Vert. Pckt.			X		Horz. Pckt.			X	
Pocket			X		Pocket			X	
Label Holder		1	3 1/16 X 7/8		Card Holder			X	
Material			X		Material			X	
Material			X		Material			X	
Material			X		Material			X	
F.C. Board		1	8 3/4 X 5 1/2		B.C. Board		1	8 3/4 X 5 1/2	
B.C. Board			X		B.B. Board			X	
Center Board			X		Board			X	
Board			X		Strip		1	2 X 6 1/8	
Cover Pad			X		Strip			X	
					B.B. Pad			X	

Product Code

Style Case Golden-Ribbed BB

Sheet Size a5 sample
X Cap.

Die No. 2702 Order No. 16057-2 Plate

Customer

C.I.M.

Metal
Total Vinyl <u>.030</u>
Quantity <u>1</u>
Date
Type Corners <u>Rd</u>
Radius <u>1/4</u>
Completed

Gauge	Thick
Tear Seal <u>.016</u>	<u>3/32</u>
Bar Seal <u>178</u>	<u>3/16</u>
Bar Seal	

No. of Feet
Tear Seal
Bar Seal
Bar Seal

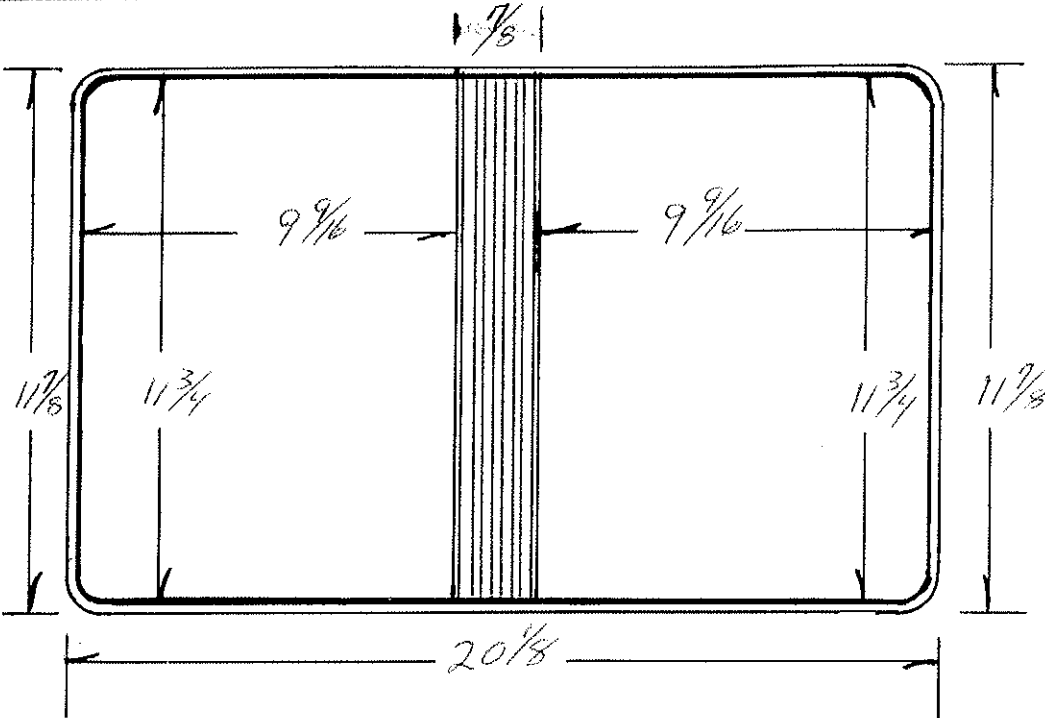

B.B. To be 4pc 3/16
with 3pc 2ft. Lead

Code		Cutting Specs		Code		Cutting Specs	
Ga.	# PCS	Size	Out	Ga.	# PCS	Size	Out
Cover Mat.		<u>12 1/2 X 20 3/4</u>	<u>1</u>	Lining Mat.		<u>12 1/2 X 20 3/4</u>	<u>1</u>
Cover Mat.	X			Lining Mat.	X		
Vert. Pckt.	X			Horz. Pckt.		<u>5 3/16 X 20 3/4</u>	
Vert. Pckt.	X			Horz. Pckt.	X		
Pocket	X			Pocket	X		
Label Holder	X			Card Holder	X		
Material	X			Material	X		
Material	X			Material	X		
Material	X			Material	X		
F.C. Board		<u>11 21/32 X 9 15/32</u>	<u>1</u>	B.C. Board		<u>11 21/32 X 9 15/32</u>	<u>1</u>
B.C. Board	X			B.B. Board	X		
Center Board	X			Board	X		
Board	X			Strip	X		
Cover Pad	X			Strip	X		
				B.B. Pad	X		

Product Code

Style Case *folder*

Sheet Size *over all* $9\frac{1}{2} \times 13\frac{1}{4}$ Cap.

Die No. *2720* Order No. *16487-1* Plate

Cook's Rest Control

stomer
tal
tal Vinyl <i>1030</i>
antity <i>30</i>
te <i>11-3-81</i>
pe Corners <i>RD</i>
dus <i>1/4</i>
mpleted

	Gauge	Thick
ar Seal	<i>1016</i>	<i>3/32</i>
r Seal	<i>103</i>	<i>1/8</i>
r Seal		

	No. of Feet
ar Seal	
r Seal	
r Seal	

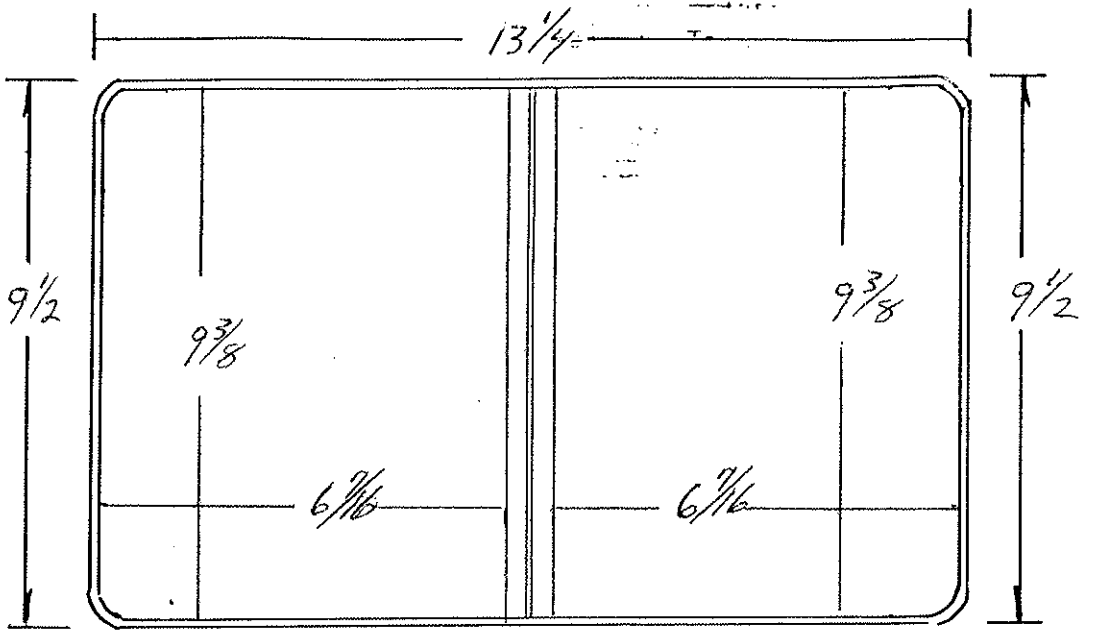

BB to be
2 PC. 103

Code	Ga.	# PCS	Cutting Specs.		Code	Ga.	# Pcs.	Cutting Specs.	
			Size	Out				Size	Out
Lining Mat.		<i>1</i>	$10\frac{1}{8} \times 13\frac{7}{8}$		Lining Mat.		<i>1</i>	$10\frac{1}{8} \times 13\frac{7}{8}$	
Lining Mat.			X		Lining Mat.			X	
Horz. Pckt.			X		Horz. Pckt.			X	
Horz. Pckt.			X		Horz. Pckt.			X	
Pocket			X		Pocket			X	
Card Holder			X		Card Holder			X	
Material			X		Material			X	
Material			X		Material			X	
Material			X		Material			X	
B.C. Board		<i>1</i>	$9\frac{1}{4} \times 6\frac{5}{16}$		B.C. Board		<i>1</i>	$9\frac{1}{4} \times 6\frac{5}{16}$	
B.B. Board			X		B.B. Board			X	
Board			X		Board			X	
Strip			X		Strip			X	
Strip			X		Strip			X	
B.B. Pad			X		B.B. Pad			X	

Product Code

Style Case *Folder*

Sheet Size *aS Sample*

Cap.

Die No. *2734*

Order No. *16703-1*

Plate

Customer

L' eggs Products

Metal
Total Vinyl <i>.030</i>
Quantity <i>1000</i>
Date <i>11-30-81</i>
Type Corners <i>Rd</i>
Radius <i>1/4</i>
Completed

	Gauge	Thick
Tear Seal	<i>.016</i>	<i>3/32</i>
Bar Seal		
Bar Seal		

	No. of Feet
Tear Seal	
Bar Seal	
Bar Seal	

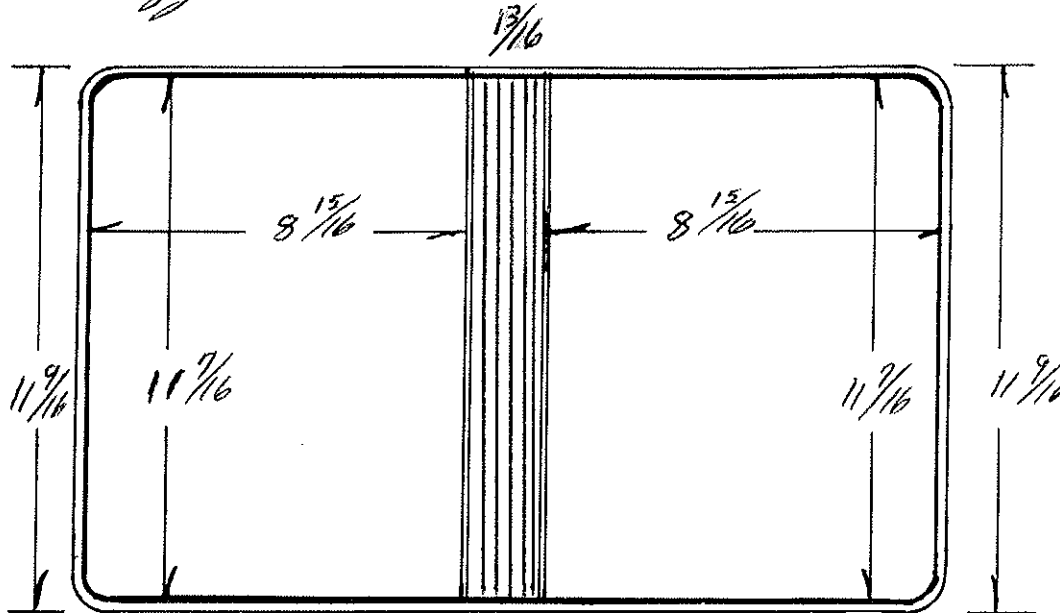

To be use
 with die no
2735 (Gussett pocket)
2736

*B B Bars to be
 3 PC. 178 grooved*

Code		Ga.	# PCS	Size	Out	Cutting Specs	Code		Ga.	# Pcs.	Size	Out	Cutting Specs
Cover Mat.	<i>12 3/16 X 19 7/16</i>		<i>1</i>				Lining Mat.	<i>12 3/16 X 19 7/16</i>		<i>1</i>			
Cover Mat	X						Lining Mat.	X					
Vert. Pckt.	X						Horz. Pckt.	X					
Vert. Pckt.	X						Horz. Pckt.	X					
Pocket	X						Pocket	X					
Label Holder	X						Card Holder	X					
Material	X						Material	X					
Material	X						Material	X					
Material	X						Material	X					
F.C. Board	<i>11 5/16 X 8 13/16</i>		<i>1</i>				B.C. Board	<i>11 5/16 X 8 13/16</i>		<i>1</i>			
B.C. Board	X						B.B. Board	X					
Center Board	X						Board	X					
Board	X						Strip	X					
Cover Pad	X						Strip	X					
							B.B. Pad	X					

Product Code

Style Case *Folder*

Sheet Size 9 X 14

Cap. 2 1/8

Die No. 3443

Order No. 950102

Plate

Coronado Paint

Customer

Metal
Total Vinyl <u>.030</u>
Quantity <u>2000</u>
Date <u>12-27-85</u>
Type Corners <u>39</u>
Radius
Completed

Gauge	Thick
Tear Seal <u>.016</u>	<u>3/32</u>
Bar Seal <u>178</u>	<u>3/16</u>
Bar Seal	

No. of Feet	
Tear Seal	
Bar Seal	
Bar Seal	

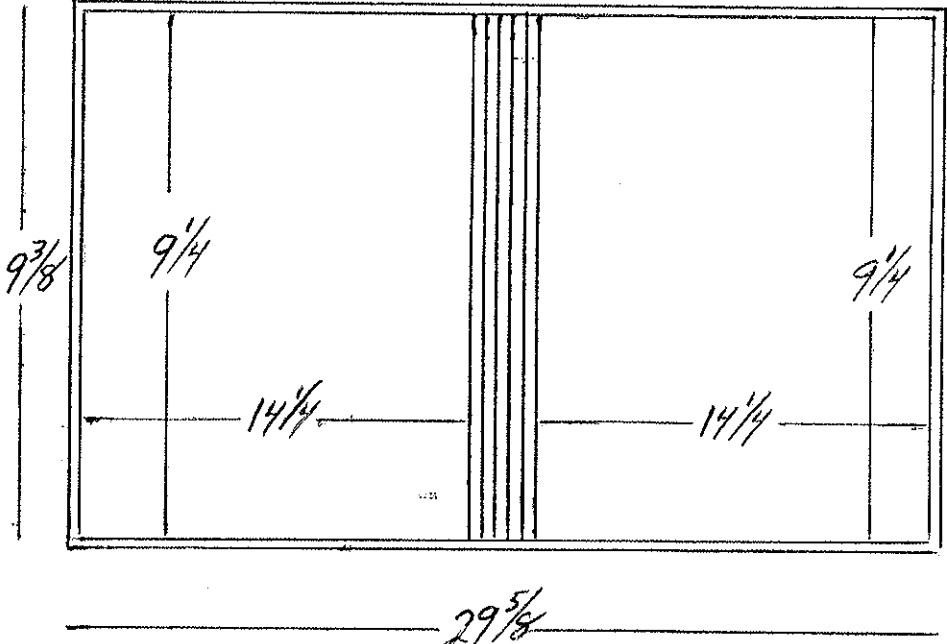

*B.B. To be 4pc.
3/16 + 6pc. 2ft. lead*

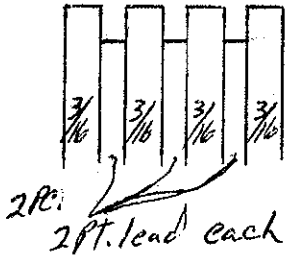

Code		Ga.	# PCS	Size	Out	Cutting Specs	Code		Ga.	# Pcs.	Size	Out	Cutting Specs
Cover Mat.	10 X 30 1/4		1				Lining Mat.	10 X 30 1/4		1			
Cover Mat	X						Lining Mat.	X					
Vert. Pckt.	X						Horz. Pckt.	9 5/16 X 14 13/16		1			
Vert. Pckt.	X						Horz. Pckt.	X					
Pocket	X						Pocket	X					
Label Holder	X						Card holder	X					
Material	X						Material	X					
Material	X						Material	X					
Material	X						Material	X					
F.C. Board	9 1/8 X 14 1/8		1				B.C. Board	9 1/8 X 14 1/8		1			
B.C. Board	X						B.B. Board	X					
Center Board	X						Board	X					
Board	X						Strip	X					
Cover Pad	X						Strip	X					
							B.B. Pad	X					

Product Code

Style Case *Calendar folder*

Sheet Size *11* X *8 1/2* Cap. *3/8* Die No. *3492* Order No. *951407* Plate

Customer

L M Berry & Co.

Metal
Total Vinyl
Quantity
Date
Type Corners <i>Rd</i>
Radius <i>1/4</i>
Completed

	Gauge	Thick
Tear Seal	<i>.016</i>	<i>3/32</i>
Bar Seal	<i>178</i>	<i>3/16</i>
Bar Seal		

	No. of Feet
Tear Seal	
Bar Seal	
Bar Seal	

*B.B. to be 4R.
#178 grooved up*

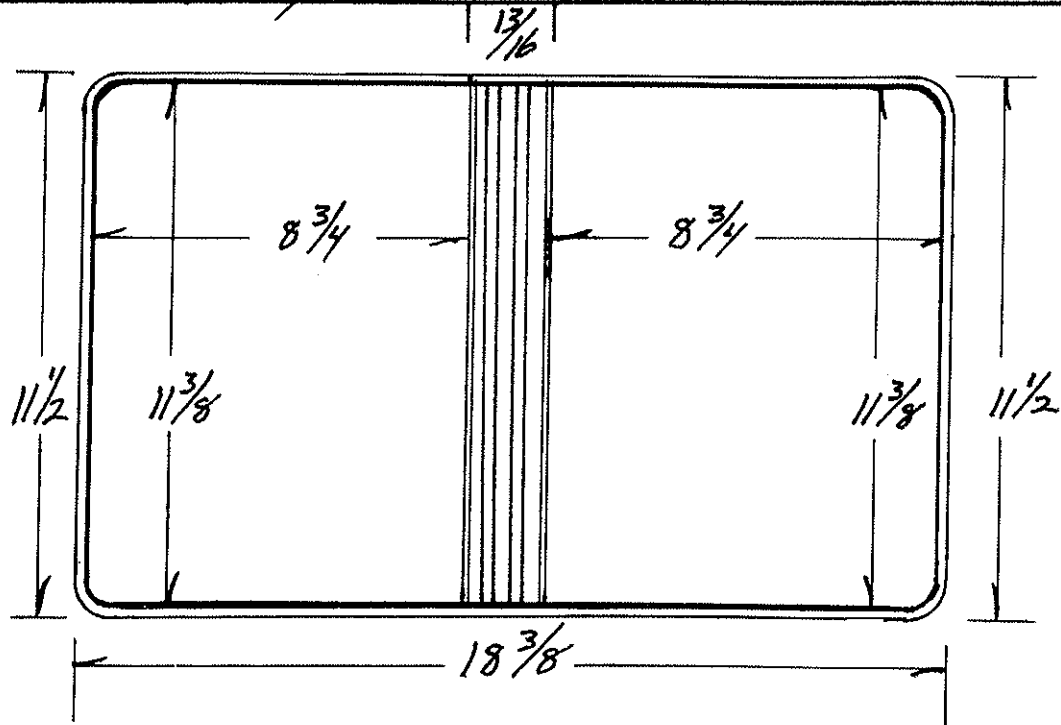

Code	Ga.	PCS	Cutting Specs		Code	Ga.	Pcs.	Cutting Specs	
			Size	Out				Size	Out
Cover Mat.			<i>12 1/8</i>	<i>X 19 1/8</i>	Lining Mat.			<i>12 1/8</i>	<i>X 19 1/8</i>
Cover Mat.				<i>X</i>	Lining Mat.				<i>X</i>
Vert. Pckt.				<i>X</i>	Horz. Pckt.			<i>5 3/8</i>	<i>X 9 1/8</i>
Vert. Pckt.			<i>12 1/8</i>	<i>X 8 13/16</i>	Horz. Pckt.			<i>5 3/8</i>	<i>X 19 1/8</i>
Pocket				<i>X</i>	Pocket			<i>5 3/8</i>	<i>X</i>
Label Holder				<i>X</i>	Card Holder				<i>X</i>
Material				<i>X</i>	Material				<i>X</i>
Material				<i>X</i>	Material				<i>X</i>
Material				<i>X</i>	Material				<i>X</i>
F.C. Board			<i>11 9/32</i>	<i>X 8 21/32</i>	B.C. Board			<i>11 9/32</i>	<i>X 8 21/32</i>
B.C. Board			<i>11 5/16</i>	<i>X 8 11/16</i>	B.B. Board				<i>X</i>
Center Board				<i>X</i>	Board				<i>X</i>
Board				<i>X</i>	Strip				<i>X</i>
Cover Pad				<i>X</i>	Strip				<i>X</i>
					B.B. Pad				<i>X</i>

Product Code VINYL

Style Case Folder

Sheet Size 9 1/4 X 12 1/2 Cap.

Die No. 3547

Order No. 952094 ~~952093~~ Plate

Customer REVELATION SEMINARS

Metal
Total Vinyl
Quantity
Date
Type Corners <u>RID</u>
Radius <u>3/32</u>
Completed

	Gauge	Thick
Tear Seal	<u>16</u>	<u>3/32</u>
Bar Seal		<u>3/32</u>
Bar Seal		

	No. of Feet
Tear Seal	
Bar Seal	
Bar Seal	

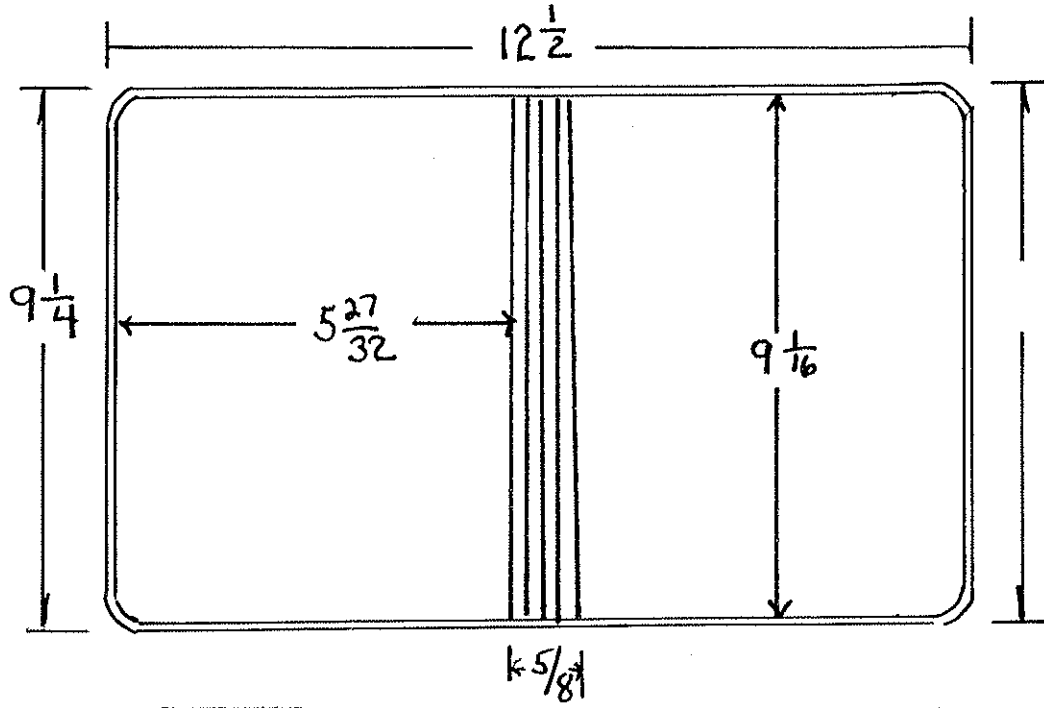

2 ps 2 PT.
Lead B/B BARS
SPACER
5 B/B BARS

Code	Ga.	# Pcs	Cutting Specs		Code	Ga.	# Pcs	Cutting Specs	
			Size	Out				Size	Out
Cover Mat.			<u>9 7/8 X 13 7/8</u>		Lining Mat.			<u>9 7/8 X 13 7/8</u>	
Cover Mat			X		Lining Mat.			X	
Vert. Pckt.			X		Horz. Pckt.			<u>4 5/16 X 13 7/8</u>	
Vert. Pckt.			X		Horz. Pckt.			X	
Pocket			X		Pocket			X	
Label Holder			X		Card Holder			X	
Material			X		Material			X	
Material			X		Material			X	
Material			X		Material			X	
F.C. Board			<u>8 15/16 X 5 3/4</u>		B.C. Board			X	
B.C. Board			<u>8 15/16 X 5 3/4</u>		B.B. Board			X	
Center Board			X		Board			X	
Board			X		Strip			X	
Cover Pad			X		Strip			X	
					B.B. Pad			X	

Product Code

Style Case *folder*

Overall
Sheet Size *6* X *6 1/4* Cap.

Die No. *3656*

Order No. *953026*

Plate

Customer

Ashton Interactive Training Corp.

Metal
Total Vinyl <i>.030</i>
Quantity <i>500</i>
Date <i>11-14-86</i>
Type Corners <i>RD</i>
Radius <i>1/4</i>
Completed

	Gauge	Thick
Tear Seal	<i>.016</i>	<i>3/32</i>
Bar Seal	<i>178</i>	<i>3/16</i>
Bar Seal		

	No. of Feet
Tear Seal	
Bar Seal	
Bar Seal	

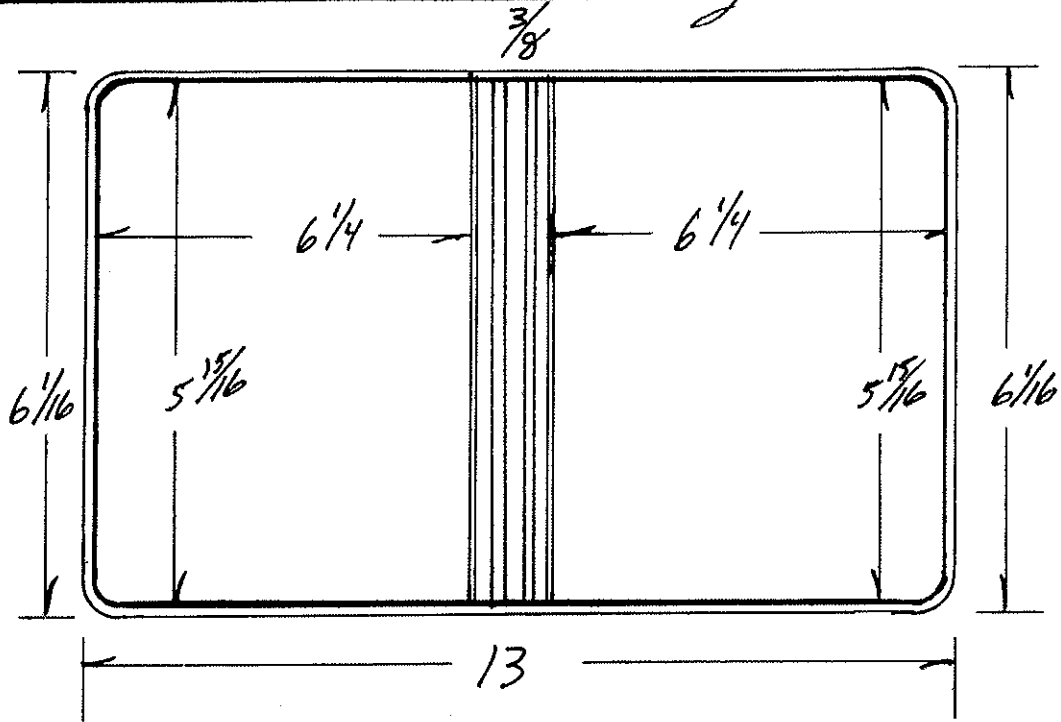

B.B. 2 PC. 3/16 grooved UP

Code	Ga.	# PCS	Cutting Specs		Code	Ga.	# Pcs.	Cutting Specs	
			Size	Out				Size	Out
Cover Mat.		<i>1</i>	<i>6 1/16 X</i>	<i>13 5/8</i>	Lining Mat.		<i>1</i>	<i>6 1/16 X</i>	<i>13 5/8</i>
Cover Mat.			X		Lining Mat.			X	
Vert. Pckt.			X		Horz. Pckt.		<i>1</i>	<i>3 5/16 X</i>	<i>13 5/8</i>
Vert. Pckt.			X		Horz. Pckt.			X	
Pocket			X		Pocket			X	
Label Holder			X		Card Holder			X	
Material			X		Material			X	
Material			X		Material			X	
Material			X		Material			X	
F.C. Board		<i>1</i>	<i>5 1/32 X</i>	<i>6 5/32</i>	B.C. Board		<i>1</i>	<i>5 1/32 X</i>	<i>6 5/32</i>
B.C. Board			X		B.B. Board			X	
Center Board			X		Board			X	
Board			X		Strip			X	
Cover Pad			X		Strip			X	
					B.B. Pad			X	

Product Code

Style Case *Diskette holder*

Sheet Size *H.O. FC* 9 X 6

Cap. *3/4*

Die No. *3669*

Order No. *953940*

Plate

Customer

Management Control Systems

Metal
Total Vinyl <i>.030</i>
Quantity <i>500</i>
Date <i>11-2-76</i>
Type Corners <i>Rd</i>
Radius <i>1/4</i>
Completed

	Gauge	Thick
Tear Seal	<i>.016</i>	<i>3/32</i>
Bar Seal	<i>178</i>	<i>3/16</i>
Bar Seal		

	No. of Feet
Tear Seal	
Bar Seal	
Bar Seal	

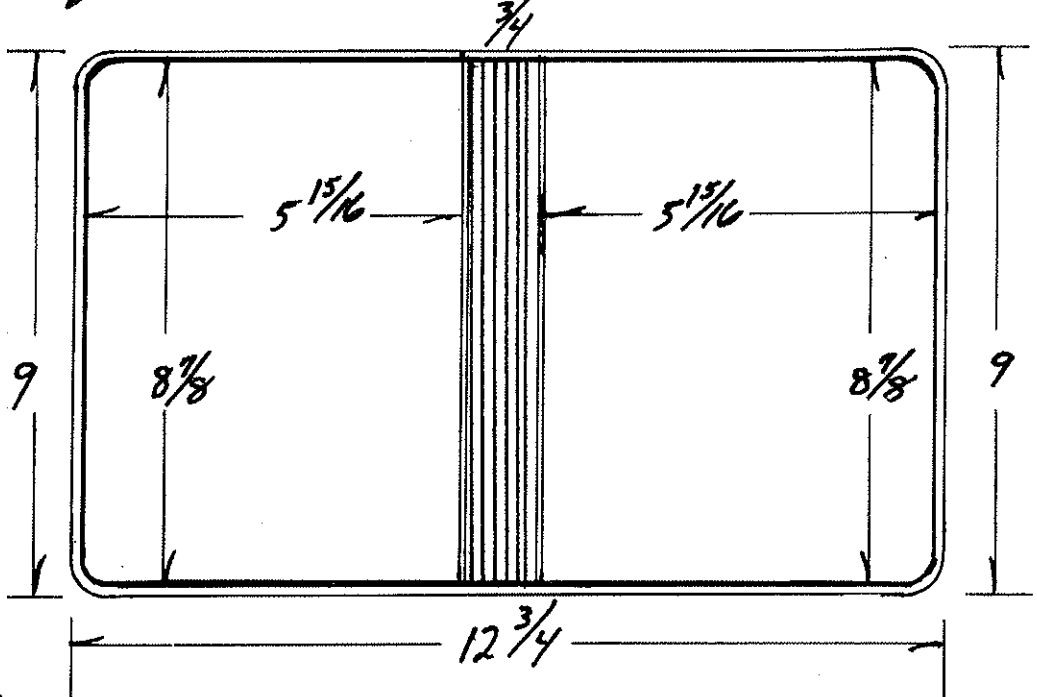

*B.B. to be 4pc.
3/16 grooved up*

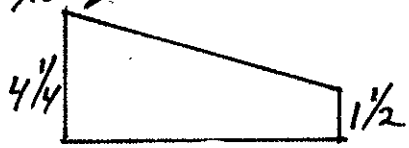

Code *6 7/8*

	Code	Ga.	# PCS	Cutting Specs		Code	Ga.	# Pcs.	Cutting Specs	
				Size	Out				Size	Out
Cover Mat.			<i>1</i>			Lining Mat.		<i>1</i>		
Cover Mat.						Lining Mat.				
Vert. Pckt.			<i>1</i>			Horz. Pckt.		<i>1</i>		
Vert. Pckt.						Horz. Pckt.				
Pocket			<i>1</i>			Pocket				
Label Holder						Card Holder				
Material						Material				
Material						Material				
Material						Material				
F.C. Board			<i>1</i>			B.C. Board				
B.C. Board						B.B. Board				
Center Board						Board				
Board						Strip				
Cover Pad						Strip				
						B.B. Pad				

DIE #	3582	METAL		RADIUS	1/4"
ORDER #	952448	CUSTOMER	LIBERTY NATIONAL INS.	TEAR SEAL	.016
SHEET SIZE	11 X 9	STYLE CASE	FOLDER	BAR SEAL	178
CAP.	3/8	DUE DATE		COMPLETED	
LOCATION		QUANTITY		DATE	8-15-96

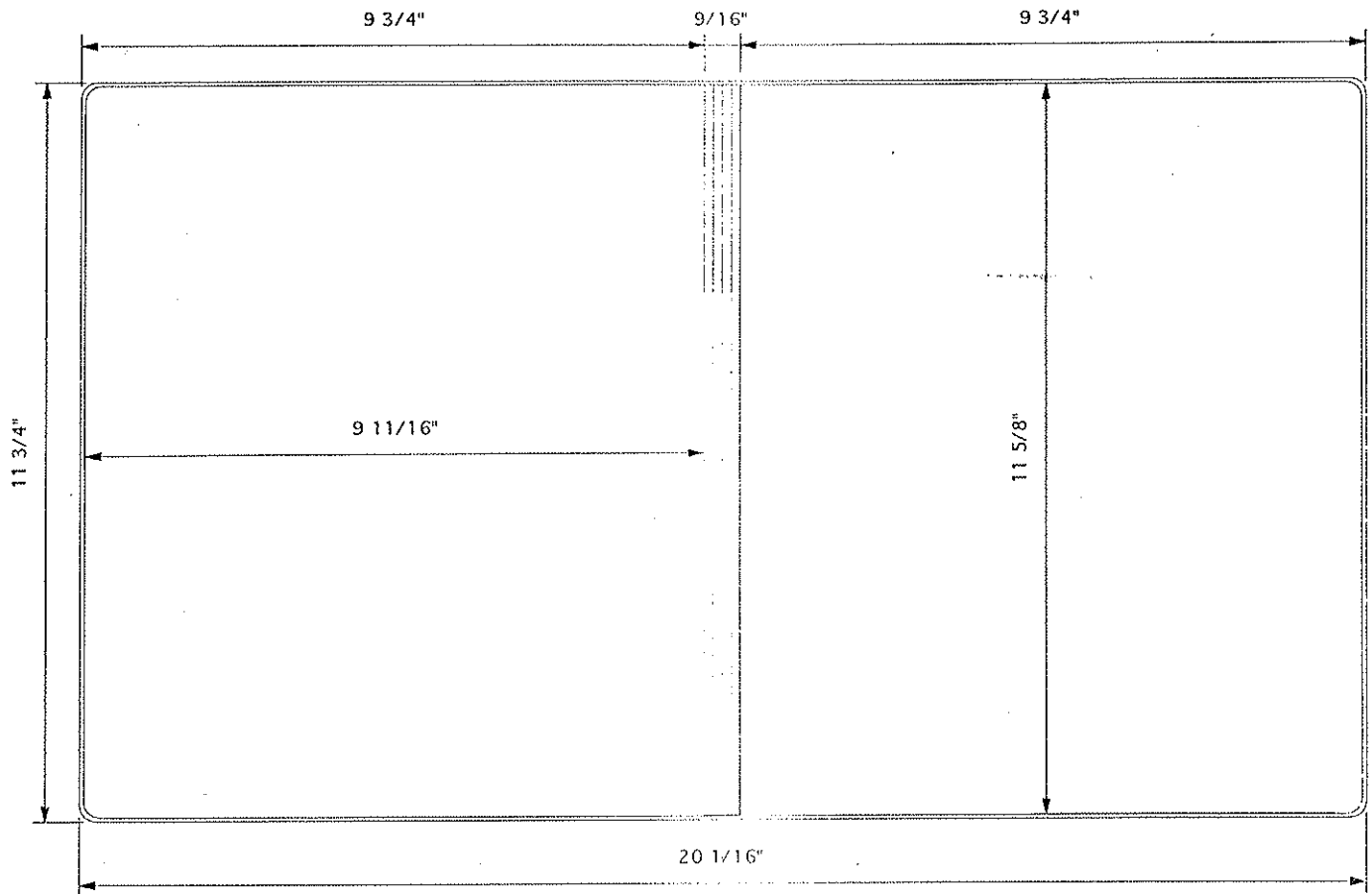

MATERIAL SPECS		GAUGE		PCS.		MATERIAL SPECS		GAUGE	
COVER MAT.	12 3/8 X 20 13/16			1		LINING MAT.	12 3/8 X 20 13/16		
COVER MAT.	12 3/4 X 21 1/8		FOR PADDED	1		5" HORZ. PKT.	5 3/8 X 10 1/4		
DIE CUT						4" HORZ. PKT.	4 3/8 X 10 1/4		
COL						VERT. PKT.	12 3/8 X 9 3/4		
LABEL HOLDER						DIE CUT			
GUSSET						REINF.			

BOARD SPECS		GAUGE		PCS.		BOARD SPECS		GAUGE	
F.C. BOARD	11 9/16 X 9 5/8	100		1		F.C. BOARD	11 17/32 X 9 19/32	120	
B.B. BOARD						B.B. BOARD			
B.C. BOARD	11 9/16 X 9 5/8	100		1		B.C. BOARD	11 17/32 X 9 19/32	120	
FLAP BD.						DIE CUT			
BOARD						DIE CUT	10 1/2 X 24 1/2	PADDED	DIECUT 3582-A

Product Code

Style Case *Vinyl folder*

Sheet Size $8\frac{1}{2}$ X $5\frac{1}{2}$ Cap.

Die No. *3693*

Order No. *953887*

Plate

Customer

Creditor Resources

Metal
Total Vinyl <i>.030</i>
Quantity <i>300</i>
Date <i>12-12-86</i>
Type Corners <i>Rd</i>
Radius <i>1/4</i>
Completed

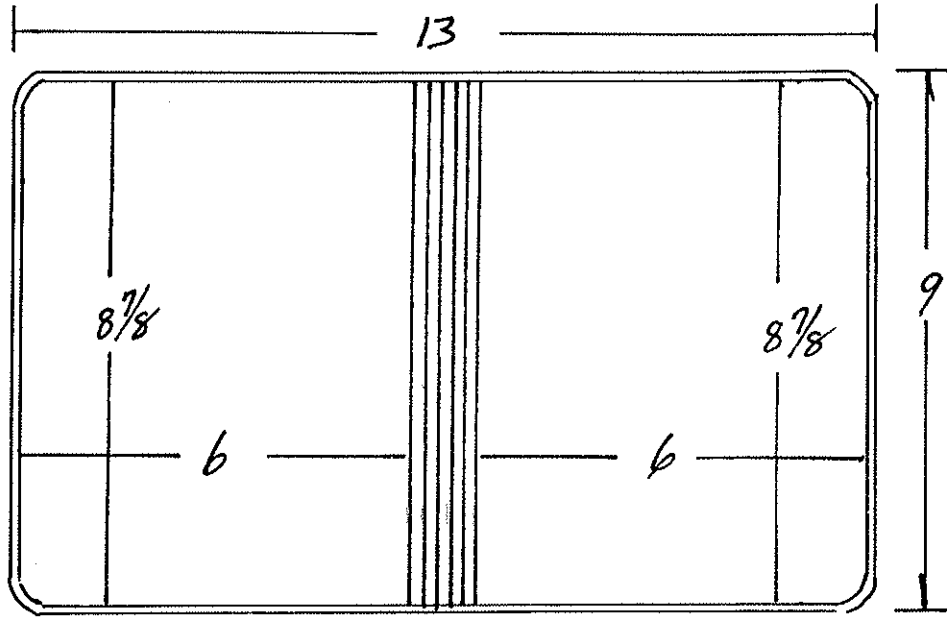

	Gauge	Thick
Tear Seal	<i>.016</i>	<i>3/32</i>
Bar Seal	<i>178</i>	<i>3/16</i>
Bar Seal		

	No. of Feet
Tear Seal	
Bar Seal	
Bar Seal	

*B.B. To 4pc. 178
grooved up +
3pc. 2ft. Lead*

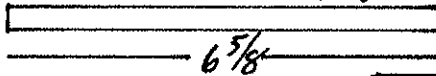

Code	Ga.	PCS	Cutting Specs		Code	Ga.	Pcs.	Cutting Specs	
			Size	Out				Size	Out
Cover Mat.		<i>1</i>	$9\frac{5}{8}$ X $13\frac{5}{8}$		Lining Mat.		<i>1</i>	$9\frac{5}{8}$ X $13\frac{5}{8}$	
Cover Mat.			X		Lining Mat.			X	
Vert. Pckt.		<i>1</i>	$9\frac{5}{8}$ X $5\frac{15}{16}$		Horz. Pckt.		<i>1</i>	$3\frac{1}{8}$ X $6\frac{5}{8}$	
Vert. Pckt.			X		Horz. Pckt.		<i>1</i>	$3\frac{5}{16}$ X $6\frac{7}{8}$	
Pocket			X		Pocket			X	
Label Holder			X		Card Hlder			X	
Material			X		Material			X	
Material			X		Material			X	
Material			X		Material			X	
F.C. Board		<i>1</i>	$8\frac{13}{16}$ X $5\frac{15}{16}$		B.C. Board		<i>1</i>	$8\frac{13}{16}$ X $5\frac{15}{16}$	
B.C. Board			X		B.B. Board			X	
Center Board			X		Board			X	
Board			X		Strip			X	
Cover Pad			X		Strip			X	
					B.B. Pad			X	

Product Code

Style Case *Folder*

Sheet Size *25 Sample* X

Cap.

Die No. *3825*

Order No. *955721*

Plate

Reliable Life Corp.

Customer	Metal	
Total Vinyl	<i>.030</i>	
Quantity	<i>500</i>	
Date	<i>6-22-87</i>	
Type Corners	<i>R0</i>	
Radius	<i>3/32</i>	
Completed		

	Gauge	Thick
Tear Seal	<i>.016</i>	<i>3/32</i>
Bar Seal	<i>20</i>	<i>1/32</i>
Bar Seal		

	No. of Feet
Tear Seal	
Bar Seal	
Bar Seal	

*B.B. To be 3 Pcs. #20
+ 4 Pcs. 2 Pk. Lead*

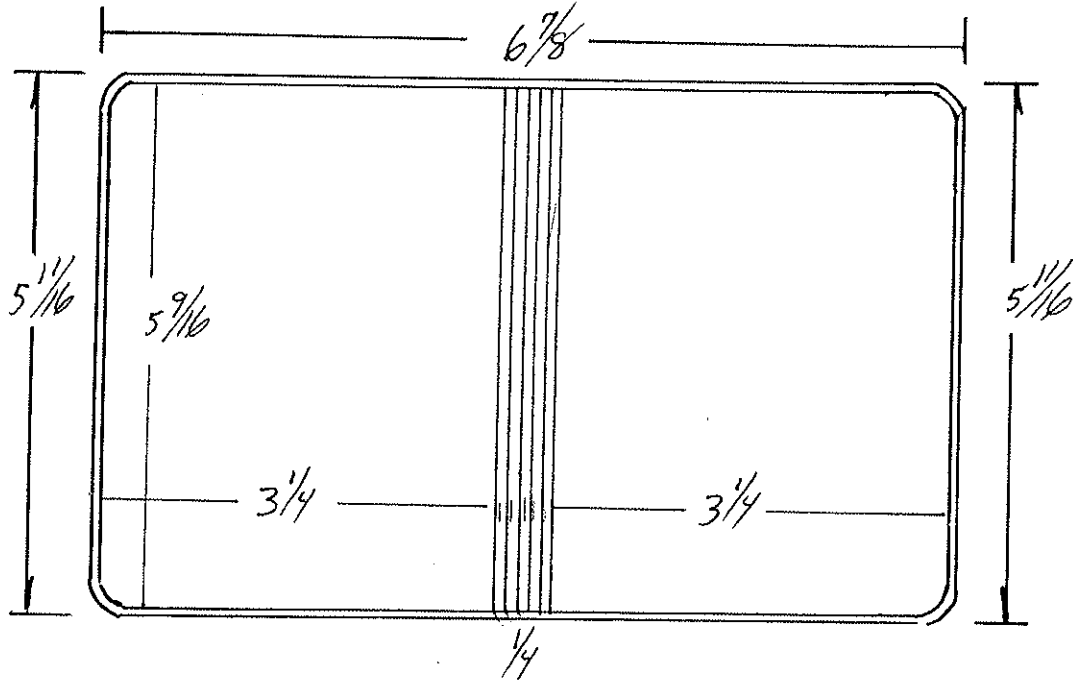

Code	Ga.	#	Cutting Specs		Code	Ga.	#	Cutting Specs	
			Size	Out				Size	Out
Cover Mat.			<i>5/16 X 7/2</i>		Lining Mat.			<i>5/16 X 7/2</i>	
Cover Mat.			X		Lining Mat.			X	
Vert. Pckt.			<i>5 3/8 X 3 3/8</i>		Horz. Pckt.			X	
Vert. Pckt.			X		Horz. Pckt.			X	
Pocket			X		Pocket			X	
Label Holder			X		Card Holder			X	
Material			X		Material			X	
Material			X		Material			X	
Material			X		Material			X	
B.C. Board			X		B.C. Board			X	
B.C. Board			X		B.B. Board			X	
Enter Board			X		Board			X	
Board			X		Strip			X	
Cover Pad			X		Strip			X	
					B.B. Pad			X	

old 1342

Product Code

Style Case

Folder

Sheet Size

X

Cap.

Die No. 3884

Order No. 956253

Plate

Customer

D A South

Metal
Total Vinyl
Quantity
Date
Type Corners Ad.
Radius 3/32
Completed

	Gauge	Thick
Tear Seal	16	3/32
Bar Seal	253	
Bar Seal		

	No. of Feet
Tear Seal	
Bar Seal	
Bar Seal	

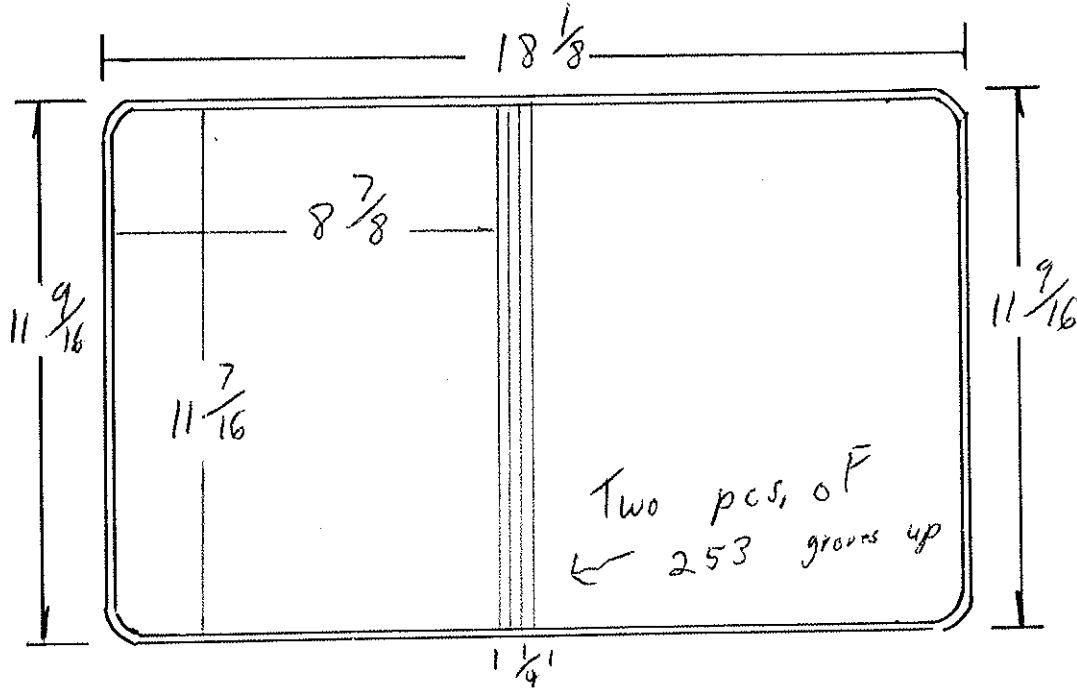

Code	Ga.	# PCS	Cutting Specs		Code	Ga.	# Pcs.	Cutting Specs	
			Size	Out				Size	Out
Cover Mat.		1	12 3/16 X 18 3/4		Lining Mat.		1	12 3/16 X 18 3/4	
Cover Mat			X		Lining Mat.			X	
Vert. Pckt.			X		Horz. Pckt.		1	5 3/8 X 18 3/4	
Vert. Pckt.			X		Hbrz. Pckt.			X	
Pocket			X		Pocket			X	
Label Holder			X		Card Holder			X	
Material			X		Material			X	
Material			X		Material			X	
Material			X		Material			X	
F.C. Board		1	11 3/8 X 8 13/16		B.C. Board		1	11 3/8 X 8 13/16	
B.C. Board			X		B.B. Board			X	
Center Board			X		Board			X	
Board			X		Strip			X	
Cover Pad			X		Strip			X	
					B.B. Pad			X	

Product Code

Style Case *folder*

Sheet Size *11 1/2 X 8 1/2* Cap. *1/2* Die No. *3989* Order No. *58784* Plate

Customer	<i>8 1/2 x 11 1/2</i>
Metal	
Total Vinyl	<i>.030</i>
Quantity	<i>50</i>
Date	<i>3-30-80</i>
Type Corners	<i>45 RD</i>
Radius	<i>1/4</i>
Completed	

MSC

	Gauge	Thick
Tear Seal	<i>.016</i>	<i>3/32</i>
Bar Seal	<i>178</i>	<i>3/16</i>
Bar Seal		

	No. of Feet
Tear Seal	
Bar Seal	
Bar Seal	

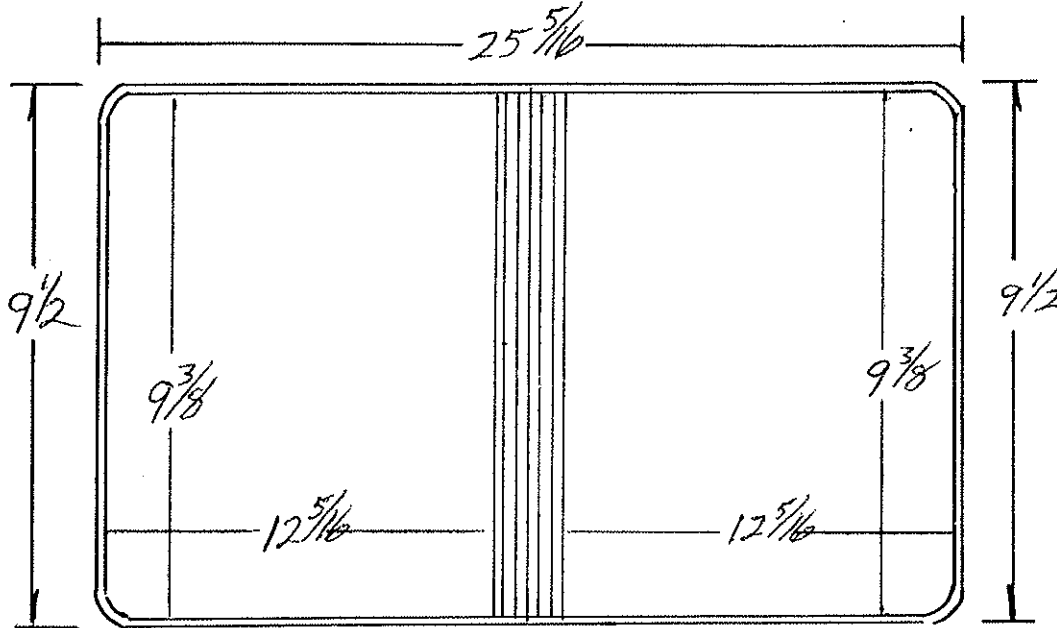

1/16 Back bone
To be 3pc.
#178 grooved up
K.P.D.

Code		Ga.	# PCS	Size	Out	Cutting Specs.	Code		Ga.	# Pcs.	Size	Out	Cutting Specs.
Cover Mat.			<i>1</i>	<i>10 1/8 x 25 15/16</i>			Lining Mat.			<i>1</i>	<i>10 1/8 x 25 15/16</i>		
Cover Mat.				X			Lining Mat.				X		
Vert. Pckt.	<i>clear</i>		<i>1</i>	<i>10 1/8 x 12 1/4</i>			Horz. Pckt.				X		
Vert. Pckt.			<i>1</i>	<i>10 1/8 x 12 1/4</i>			Horz. Pckt.				X		
Pocket				X			Pocket				X		
Label Holder				X			Card Holder				X		
Material				X			Material				X		
Material				X			Material				X		
Material				X			Material				X		
F.C. Board			<i>1</i>	<i>9 9/32 x 12 7/32</i>			B.C. Board			<i>1</i>	<i>9 9/32 x 12 7/32</i>		
B.C. Board				X			B.B. Board				X		
Center Board				X			Board				X		
Board				X			Strip				X		
Cover Pad				X			Strip				X		
							B.B. Pad				X		

Product Code

Style Case *Diskette holder*

Sheet Size *as drawings*

Cap.

Die No. *4030*

Order No. *959153*

Plate

Customer

Texas Instruments

Metal
Total Vinyl <i>.008</i>
Quantity <i>50</i>
Date <i>6-8-88</i>
Type Corners <i>Rd</i>
Radius <i>3/8</i>
Completed

	Gauge	Thick
Tear Seal	<i>.012</i>	<i>3/32</i>
Bar Seal	<i>178</i>	<i>3/16</i>
Bar Seal	<i>20</i>	<i>3/32</i>

	No. of Feet
Tear Seal	
Bar Seal	
Bar Seal	

*Bar bone to be
2 pc. #178 grooved up
2 pc. stainless steel
1 pc. #20*

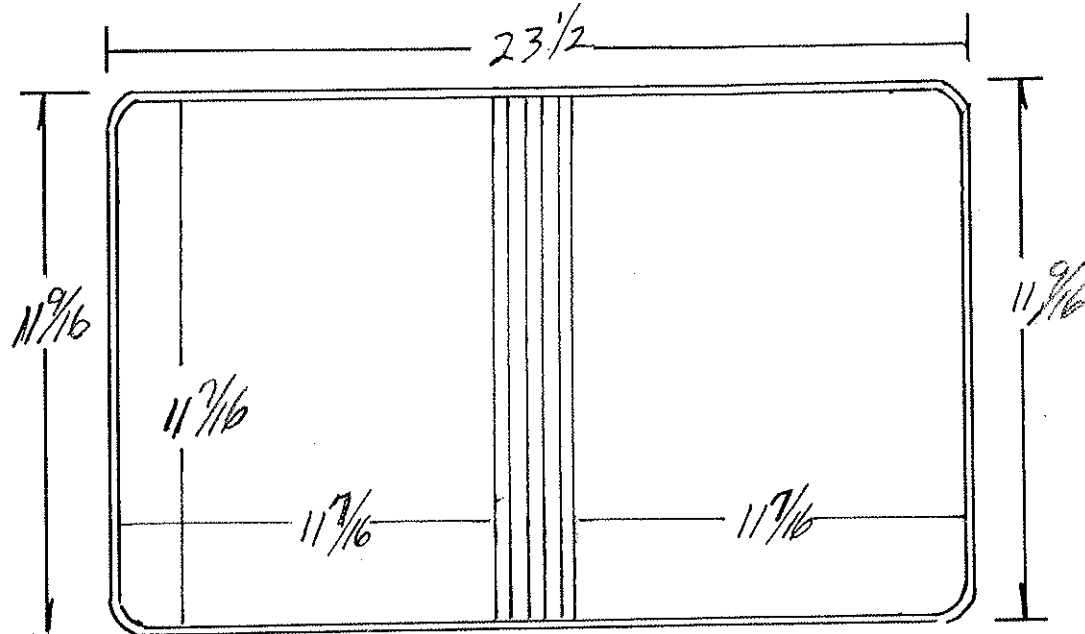

Code	Cutting Specs				Code	K.P.O.	Cutting Specs				
	Ga.	#	Size	Out			Ga.	#	Size	Out	
Cover Mat.			<i>12 3/16</i>	<i>24 1/4</i>	Lining Mat.			<i>12 3/16</i>	<i>24 1/4</i>		
Cover Mat			X		Lining Mat.			X			
Vert. Pckt.			X		Horz. Pckt. C.F.C.			<i>11 5/8</i>	<i>13</i>		<i>1</i>
Vert. Pckt.			<i>12 3/16</i>	X	<i>4 7/8</i>			X			
Pocket			X		Pocket			X			
Label Holder			X		Card Holder			X			
Material			X		Material			X			
Material			X		Material			X			
Material			X		Material			X			
F.C. Board			<i>11 11/32</i>		B.C. Board			<i>11 11/32</i>	<i>11 11/32</i>		<i>1</i>
B.C. Board			X		B.B. Board			X			
Center Board			X		Board			X			
Board			X		Strip			X			
Cover Pad			X		Strip			X			
					B.B. Pad			X			

Product Code

Style Case 2-UP VINYL FOLDER

Sheet Size 6 1/4 x 4 1/4

Cap. 3/8"

Die No. 4084

Order No. 960451

Plate

Customer

PRAKON

4085

Metal
Total Vinyl
Quantity
Date <u>12-20-88</u>
Type Corners <u>RND</u>
Radius <u>3/16</u>
Completed

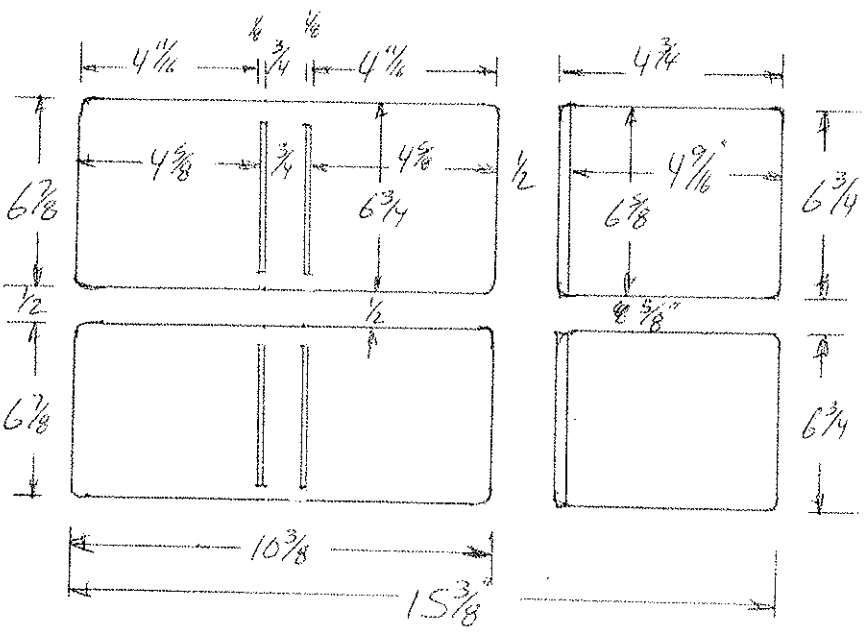

	Gauge	Thick
Tear Seal	<u>016</u>	<u>3/32</u>
Bar Seal	<u>253</u>	<u>1/16</u>
Bar Seal		

	No. of Feet
Tear Seal	
Bar Seal	
Bar Seal	

REDRAWN 12-20-88 G.P.

Code	Ga.	# PCS	Cutting Specs		Code	Ga.	# Pcs.	Cutting Specs	
			Size	Out				Size	Out
Cover Mat.		<u>17 1/2 x 16</u>	<u>15</u>	<u>1</u>	Lining Mat.		<u>17 1/2 x 16</u>	<u>15</u>	<u>1</u>
Cover Mat		X			Lining Mat.		X		
Vert. Pckt.		X			Horz. Pckt.		X		
Vert. Pckt.		X			Horz. Pckt.		X		
Pocket		X			Pocket		X		
Label Hoker		X			Card blder		X		
Material		X			Material		X		
Material		X			Material		X		
Material		X			Material		X		
F.C. Board		<u>16 1/2 x 15</u>		<u>1</u>	B.C. Board		X		
B.C. Board		X			B.B. Board		X		
Center Board		X			Board		X		
Board		X			Strip		X		
Cover Pad		X			Strip		X		
					B.B. Pad		X		

Product Code

Style Case FOLDER

Sheet Size 3 1/2 x 6 Cap.

Die No. 4097 Order No. 960996

Plate

Customer GENERAL ELECTRIC CO.

11-18-88

Metal
Total Vinyl
Quantity
Date
Type Corners
Radius
Completed

	Gauge	Thick
Tear Seal	9/16	1/16
Bar Seal	#42 R	1/16
Bar Seal		

	No. of Feet
Tear Seal	
Bar Seal	
Bar Seal	

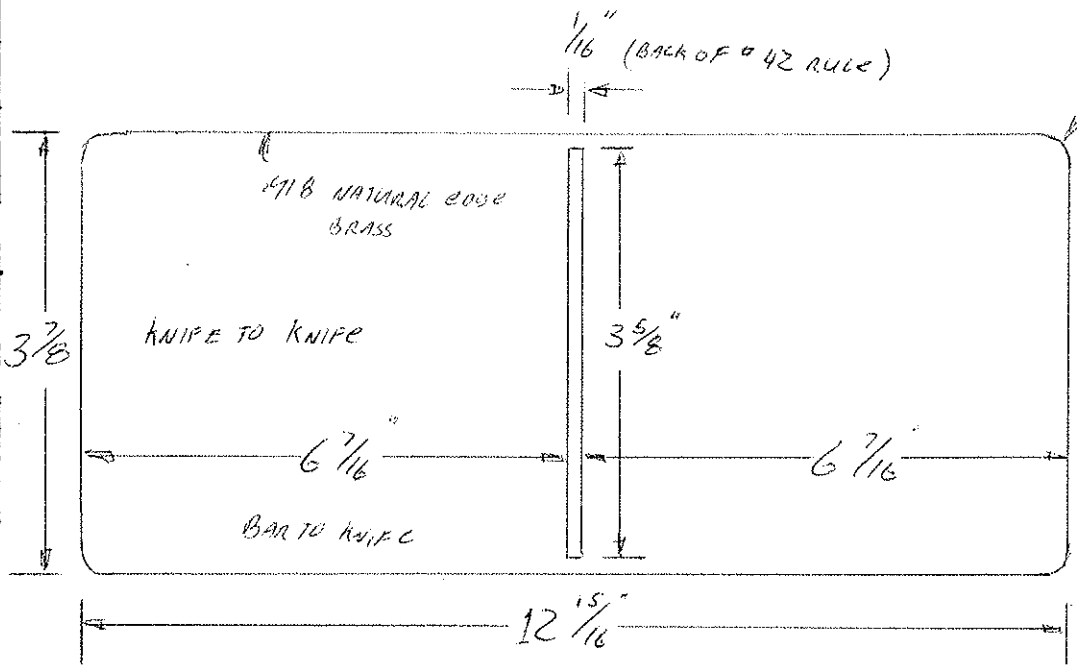

Code	Ga.	Pcs	Cutting Specs		Code	Ga.	Pcs	Cutting Specs	
			Size	Out				Size	Out
Cover Mat.		15	4 5/8" x 13 3/4"	1	Lining Mat.	15	1	4 5/8" x 13 3/4"	
Cover Mat			X		Lining Mat.			X	
Vert. Pckt.		15	4 5/8" x 6 1/2"	1	Horz. Pckt.			X	
Vert. Pckt.		15	4 5/8" x 6 1/2"	1	Horz. Pckt.			X	
Pocket			X		Pocket			X	
Label Hoker			X		Card Hlder			X	
Material			X		Material			X	
Material			X		Material			X	
Material			X		Material			X	
F.C. Board			3 5/8" x 6 5/16"		B.C. Board			X	
B.C. Board			3 5/8" x 6 5/16"		B.B. Board			X	
Center Board			X		Board			X	
Board			X		Strip			X	
Cover Pad			X		Strip			X	
					B.B. Pad			X	

Product Code

Style Case *FOLDER*

Sheet Size *11* x *8 1/2* Cap. *3/4"*

Die No. *4133*

Order No. *961668.1*

Plate

Customer *WESTAT INC.*

Metal
Total Vinyl
Quantity <i>150</i>
Date
Type Corners <i>RAD</i>
Radius <i>3/8"</i>
Completed

	Gauge	Thick
Tear Seal	<i>16</i>	<i>3/32</i>
Bar Seal		<i>3/4</i>
Bar Seal		

	No. of Feet
Tear Seal	
Bar Seal	
Bar Seal	

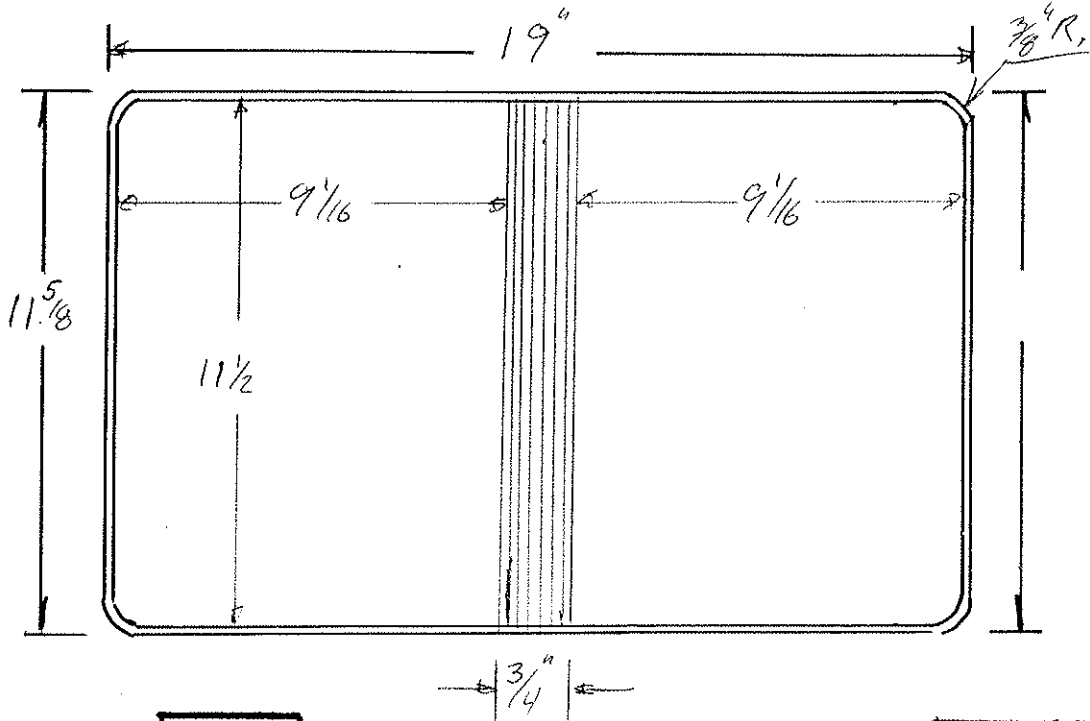

USE GUSSET DIE # 4134

Code	Ga.	PCS	Cutting Specs		Code	Ga.	Pcs.	Cutting Specs	
			Size	Out				Size	Out
Cover Mat.		<i>12 3/8 X 19 3/4</i>	<i>15</i>	<i>1</i>	Lining Mat.		<i>12 3/8 X 19 3/4</i>	<i>15</i>	<i>1</i>
Cover Mat.		X			Lining Mat.		X		
Vert. Pckt.		X			Horz. Pckt.		<i>7 3/8 X 19 3/4</i>	<i>15</i>	<i>1</i>
Vert. Rckt.		X			Horz. Pckt.		<i>5 3/8 X 19 3/4</i>	<i>15</i>	<i>1</i>
Pocket		X			Pocket		X		
Label Holder		X			Card Hlder		X		
Material		X			Material		X		
Material		X			Material		X		
Material		X			Material		X		
F.C. Board		<i>11 13/32 X 8 3/32</i>	<i>100</i>	<i>1</i>	B.C. Board		<i>11 13/32 X 8 3/32</i>	<i>100</i>	<i>1</i>
B.C. Board		X			B.B. Board		X		
Center Board		X			Board		X		
Board		X			Strip		X		
Cover Pad		X			Strip		X		
					B.B. Pad		X		

Product Code

Style Case

Sheet Size 11 x 8 1/2 Cap. 9/16"

Die No. 4188

Order No. 962361

Plate

Customer

BOSCO

Metal
Total Vinyl
Quantity
Date
Type Corners
Radius
Completed

	Gauge	Thick
Tear Seal	016	3/32
Bar Seal		3/16"
Bar Seal		

	No. of Feet
Tear Seal	
Bar Seal	
Bar Seal	

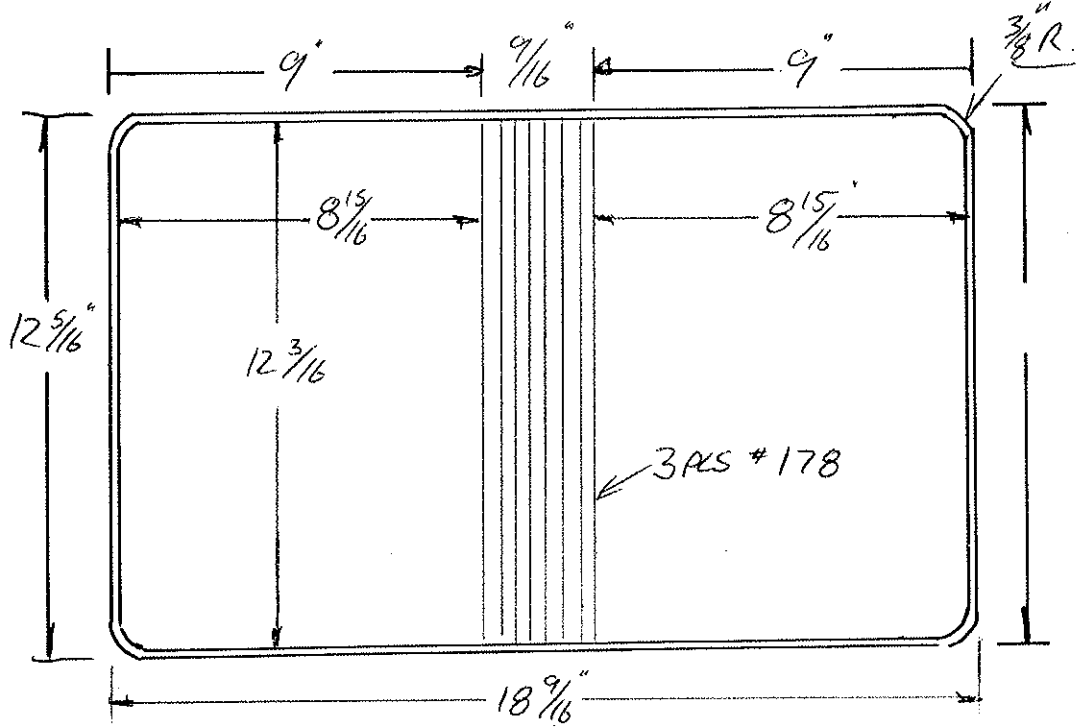

Code	Ga.	Pcs	Cutting Specs		Code	Ga.	Pcs.	Cutting Specs.	
			Size	Out				Size	Out
Cover Mat.		15	1		Lining Mat.		15	1	
Cover Mat.					Lining Mat.				
Vert. Pckt.					Horz. Pckt.				
Vert. Pckt.					Horz. Pckt.				
Pocket					Pocket	C.O.L.			
Label Holder					Card Holder	F.C.			
Material					Material				
Material					Material				
Material					Material				
F.C. Board			1		B.C. Board				
B.C. Board			1		B.B. Board				
Center Board					Board				
Board					Strip				
Cover Pad					Strip				
					B.B. Pad				

Product Code

Style Case *C.O.L. FOLDER*

Sheet Size $9\frac{1}{8}$ x $8\frac{1}{2}$ Cap. $\frac{1}{4}$ Die No. 4261

Order No. 963356 Plate

Customer *JOHN HARLAND CO.*

Metal
Total Vinyl
Quantity
Date <i>8-16-89</i>
Type Corners <i>RND</i>
Radius <i>1/4"</i>
Completed

	Gauge	Thick
Tear Seal	<i>016</i>	<i>3/32</i>
Bar Seal (2)	<i>#253</i>	<i>1/8</i>
Bar Seal		

	No. of Feet
Tear Seal	
Bar Seal	
Bar Seal	

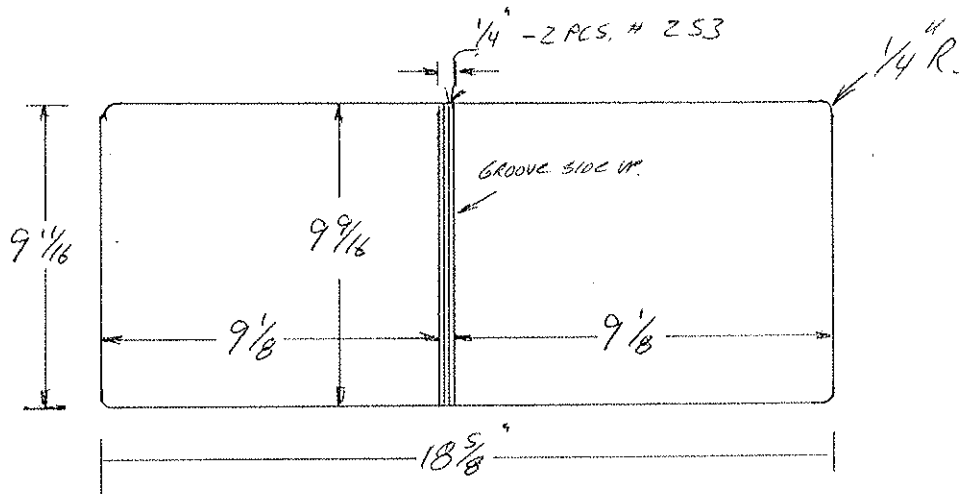

2 - 8 3/4" VERTICAL PKTS INSIDE

OPEN C.O.L.: O.F.C. & O.B.C.

Code		Ga.	#	PCS	Size	Out	Cutting Specs	Code		Ga.	#	PCS	Size	Out	Cutting Specs
Cover Mat.	$10\frac{1}{2}$ x $19\frac{1}{2}$	15		1				Lining Mat.	$10\frac{1}{2}$ x $19\frac{1}{2}$	15		1			
Cover Mat	X							Lining Mat.	X						
Vert. Pckt.	$10\frac{1}{2}$ x $9\frac{1}{8}$	8		2				Horz. Pckt. C.O.L.	$9\frac{3}{16}$ x $19\frac{1}{2}$	8		1			
Vert. Pckt.	X							Horz. Pckt.	X						
Pocket	X							Pocket	X						
Label Holder	X							Card Holder	X						
Material	X							Material	X						
Material	X							Material	X						
Material	X							Material	X						
F.C. Board	$9\frac{15}{32}$ x $9\frac{1}{32}$	100		1				B.C. Board	X						
B.C. Board	$9\frac{15}{32}$ x $9\frac{1}{32}$	100		1				B.B. Board	X						
Center Board	X							Board	X						
Board	X							Strip	X						
Cover Pad	X							Strip	X						
								B.B. Pad	X						

Product Code

L-MANEC FOLDER
Style Case **DIPLOMA COVER**

ACTUAL Sheet Size **12 1/2 x 10 1/2** Cap. **7/16"**

Die No. **4279**

Order No. **963609**

Plate

RIVERSIDE PRESS

Customer

Metal
Total Vinyl
Quantity 100
Date 12-14-85
Type Corners
Radius 3/8
Completed

	Gauge	Thick
Tear Seal	.016 R	1/16"
Bar Seal	#178	7/16"
Bar Seal		

	No. of Feet
Tear Seal	
Bar Seal	
Bar Seal	

REQUIRES CUTTING DIE
FOR TASSLE HOLDER
SEE ATTACHED SHEET

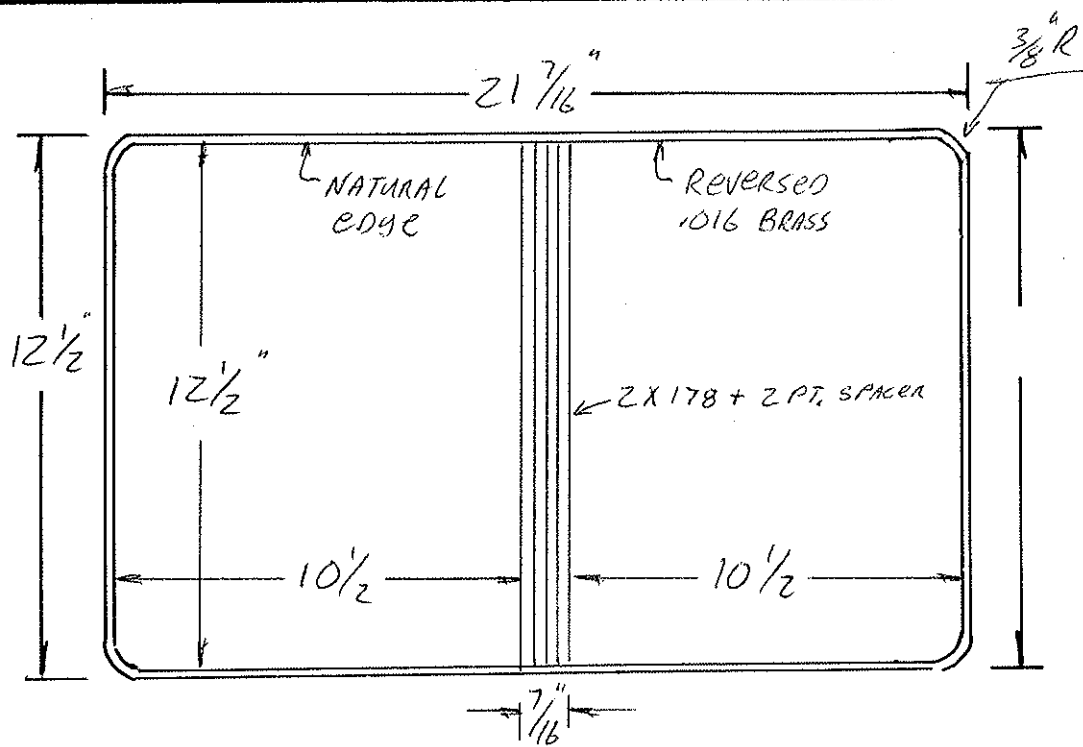

Code	Ga.	PCS	Cutting Specs		Code	Ga.	Pcs.	Cutting Specs	
			Size	Out				Size	Out
Cover Mat.			13 1/4 x 22 1/4	15 1	Lining Mat.			13 1/4 x 22 1/4	15 1
Cover Mat.			X		Lining Mat.			X	
Vert. Pckt.			POLISH X CLEAR		Horz. Pckt.			X	
Vert. Pckt.			13 1/4 x 10 3/4	8 2	Horz. Pckt.			X	
Pocket			X		Pocket			X	
Label Holder			X		Card Holder			POLISH X CLEAR	
Material			X		Material	die cut		1 x 2 1/2	8 1
Material			X		Material			TASSLE X HOLDER ↑	
Material			X		Material			X	
F.C. Board			12 13/32 x 10 13/32	100 1	B.C. Board			X	
B.C. Board			12 13/32 x 10 13/32	100 1	B.B. Board			X	
Center Board			X		Board			X	
Board			X		Strip			X	
Cover Pad			X		Strip			X	
					B.B. Pad			X	

Product Code

Style Case **VINYL FOLDER**

ACTUAL Sheet Size **12 3/4 x 21 3/8** Cap.

Die No. **4293**

Order No. **963750**

Plate

COOKSEY PRINTING

Customer

Metal
Total Vinyl
Quantity 50
Date
Type Corners RND
Radius 3/8"
Completed 10-12-82 RET

	Gauge	Thick
Tear Seal	.014	1/16"
Bar Seal	3#102	5/16"
Bar Seal		

	No. of Feet
Tear Seal	
Bar Seal	
Bar Seal	

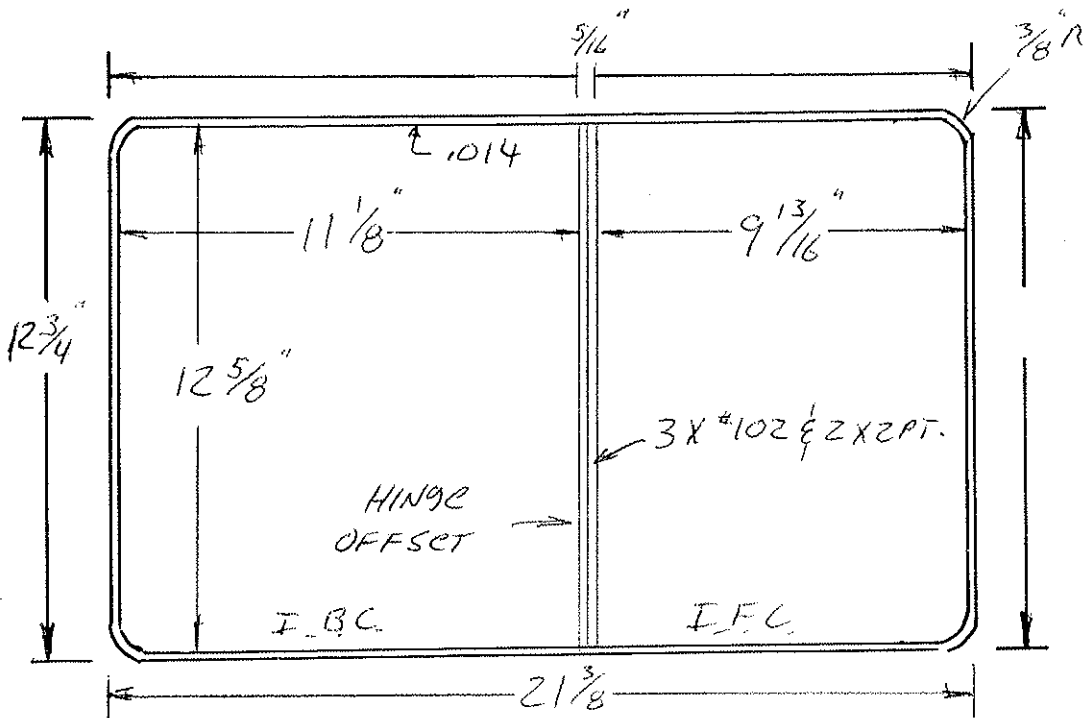

NOTE: SAMPLE IS PRINTED ON SMALL COVER

SIZE BY: B.P. ✓

CHECK BY: *gdm*

Code	Ga.	Pcs	Cutting Specs		Code	Ga.	Pcs.	Cutting Specs	
			Size	Out				Size	Out
Cover Mat.		13 1/2 x 22 1/4	15	1	Lining Mat.		13 1/2 x 22 1/4	15	1
Cover Mat		X			Lining Mat.		X		
Vert. Pckt.		X			Horz. Pckt.		X		
Vert. Pckt.		X			Horz. Pckt.		X		
Pocket		X			Pocket		X		
Label Holder		X			Card Holder		X		
Material		X			Material		X		
Material		X			Material		X		
Material		X			Material		X		
F.C. Board		12 17/32 x 11 1/32	100	1	B.C. Board		X		
B.C. Board		12 17/32 x 9 23/32	100	1	B.B. Board		X		
Center Board		X			Board		X		
Board		X			Strip		X		
Cover Pad		X			Strip		X		
					B.B. Pad		X		

Product Code

Style Case 2-PANEL FOLDER

Sheet Size 9 1/2 x 6 1/2 Cap. 7/8"

Die No. 4295

Order No. 963772

Plate

ULTRA GRAPHICS

Customer

Metal
Total Vinyl
Quantity <u>1</u>
Date <u>10-6-89</u>
Type Corners
Radius <u>3/8</u>
Completed <u>10-10-89</u> <u>B.PACE</u>

	Gauge	Thick
Tear Seal	<u>.014 R</u>	<u>1/16</u>
Bar Seal	<u>#178</u>	<u>see DWG</u>
Bar Seal		

	No. of Feet
Tear Seal	
Bar Seal	
Bar Seal	

NATURAL edge

SIZE BY: B.P.

CHECK BY: KP OR

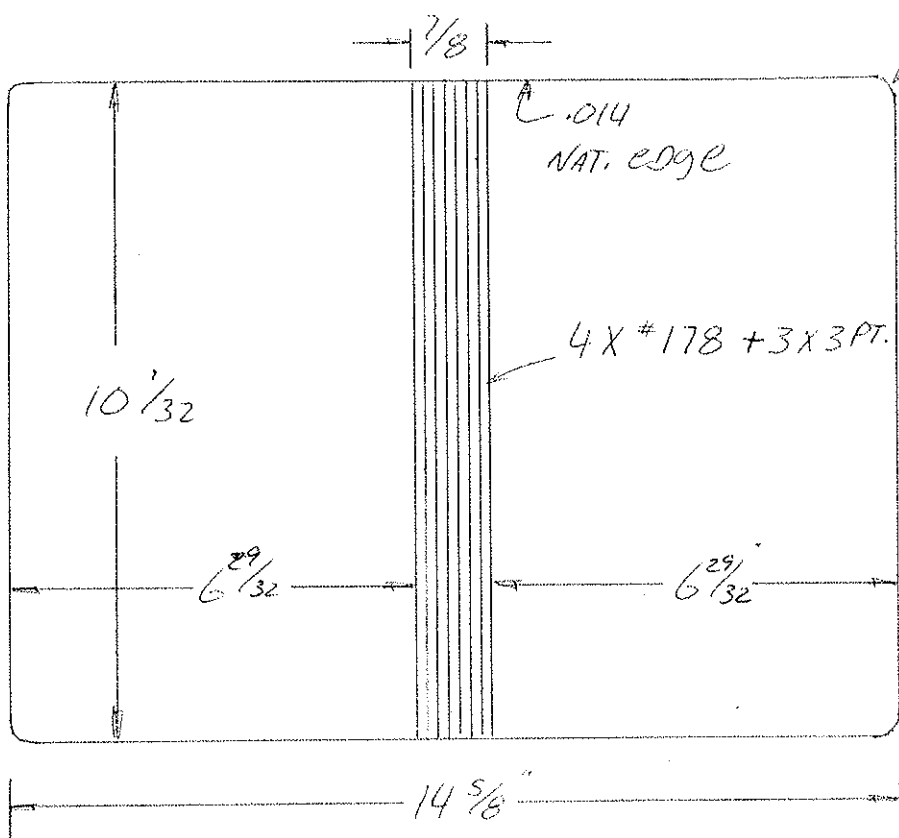

Code	Ga.	# PCS	Cutting Specs		Code	Ga.	# Pcs.	Cutting Specs		
			Size	# Out				Size	# Out	
Cover Mat.			<u>10 3/4 x 15 3/8</u>	<u>15</u>	<u>1</u>	Lining Mat.		<u>10 3/4 x 15 3/8</u>	<u>15</u>	<u>1</u>
Cover Mat			<u>X</u>			Lining Mat.		<u>X</u>		
Vert. Pckt.			<u>10 3/4 x 7"</u>	<u>8</u>	<u>1</u>	Horz. Pckt.		<u>4 3/8 x 7 3/8</u>	<u>8</u>	<u>1</u>
Vert. Rckt.			<u>X</u>			Horz. Pckt.		<u>X</u>		
Pocket			<u>X</u>			Pocket		<u>X</u>		
Label Holder			<u>X</u>			Card Hlder		<u>X</u>		
Material			<u>X</u>			Material		<u>X</u>		
Material			<u>X</u>			Material		<u>X</u>		
Material			<u>X</u>			Material		<u>X</u>		
F.C. Board			<u>9 15/16 x 6 13/16</u>	<u>100</u>	<u>1</u>	B.C. Board		<u>X</u>		
B.C. Board			<u>9 15/16 x 6 13/16</u>	<u>100</u>	<u>1</u>	B.B. Board		<u>X</u>		
Center Board			<u>X</u>			Board		<u>X</u>		
Board			<u>X</u>			Strip		<u>X</u>		
Cover Pad			<u>X</u>			Strip		<u>X</u>		
						B.B. Pad		<u>X</u>		

Product Code

Style Case VINYL FOLDER

Sheet Size 11 x 8 1/2 Cap. 1/4 Die No. 4324 Order No. 964031 Plate

SOCIAL SECURITY ADMINISTRATION

Customer

Metal
Total Vinyl
Quantity
Date
Type Corners
Radius
Completed <u>11-9-89 RET</u>

	Gauge	Thick
Tear Seal	<u>.018</u>	<u>1/16</u>
Bar Seal	<u>2253</u>	<u>1/8"</u>
Bar Seal		

	No. of Feet
Tear Seal	
Bar Seal	
Bar Seal	

11-13

SIZE BY: B.P.

CHECK BY:

RP ✓

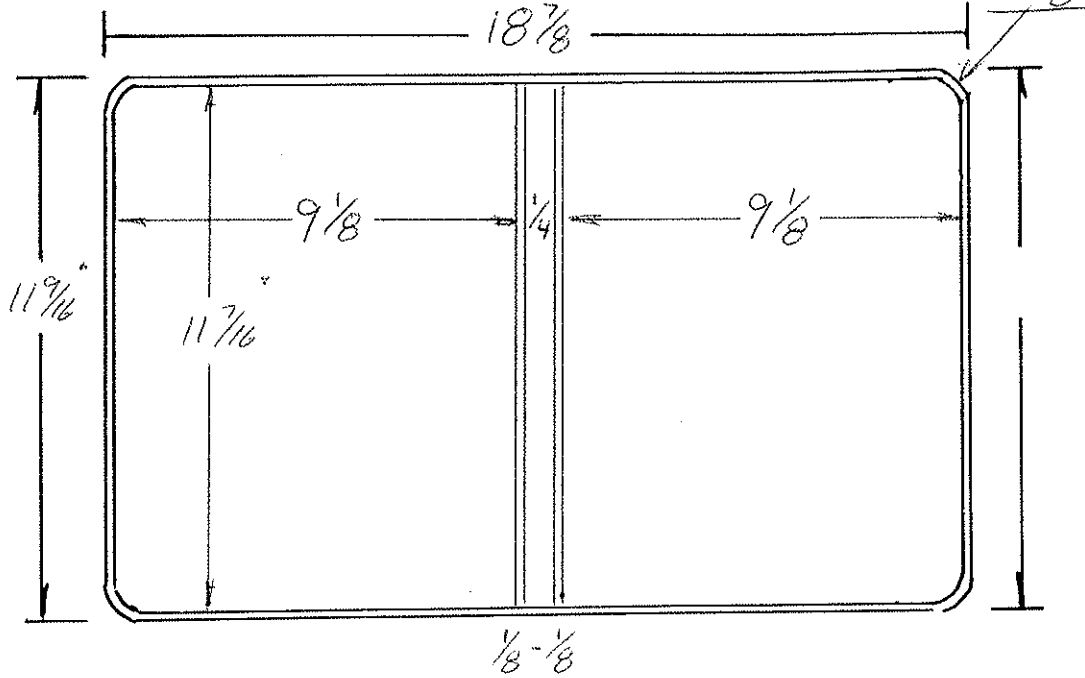

Code	Ga.	PCS	Cutting Specs		Code	Ga.	Pcs.	Cutting Specs				
			Size	Out				Size	Out			
Cover Mat.			12 1/4	19 3/4	15	1	Lining Mt.		12 1/4	19 3/4	15	1
Cover Mat				X			Lining Mat.			X		
Vert. Pckt.			12 1/4	9 1/4	8	2	Horz. Pckt.			X		
Vert. Pckt.				X			Horz. Pckt.			X		
Pocket				X			Pocket			X		
Label Holder				X			Card Hlder			X		
Material				X			Material			X		
Material				X			Material			X		
Material				X			Material			X		
F.C. Board Padded			11 1/32	9 1/32	100	1	B.C. Board			X		
B.C. Board			11 1/32	9 1/32	100	1	B.B. Board			X		
Center Board				X			Board			X		
Board			11 3/8	9 1/16	100	2	Strip			X		
Cover Pad				X			Strip			X		
							B.B. Pad			X		

OLD # 2403

Product Code

Sample

Style Case

CALENDAR HOLDER

Sheet Size

6 1/4 x 3 3/8 Cap.

Die No. 4337

Order No.

964156

Plate

PAYNE & PAYNE

Customer

Metal
Total Vinyl
Quantity
Date
Type Corners
Radius 3/8
Completed 12-4-89

Gauge	Thick
Tear Seal .008	1/16
Bar Seal #253	1/8
Bar Seal	

No. of Feet
Tear Seal
Bar Seal
Bar Seal

BY-12-4

SIZES BY B.P.
CHECK BY P.M.

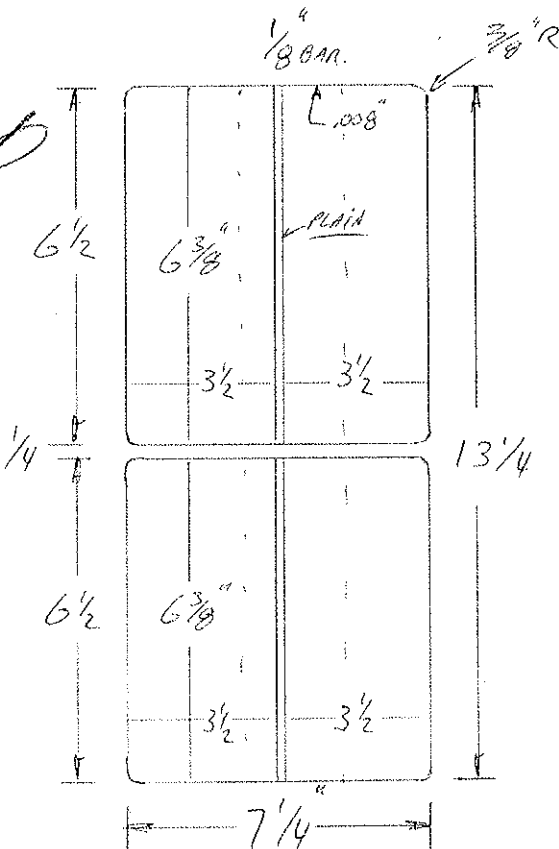

2-UP DUE TO LOW QTY.

Code	Ga.	# PCS	Cutting Specs		Code	Ga.	# Pcs.	Cutting Specs	
			Size	Out				Size	Out
Cover Mat.	14	8	16	1	2	Lining Mat.		X	
Cover Mat		X				Lining Mat.		X	
Vert. Pckt.	14	3 7/8"	8	1	2	Horz. Pckt.		X	
Vert. Pckt.	14	3 1/8"	8	1	2	Horz. Pckt.		X	
Pocket		X				Pocket		X	
Label Holder		X				Card Hlder		X	
Material		X				Material		X	
Material		X				Material		X	
Material		X				Material		X	
F.C. Board		X				B.C. Board		X	
B.C. Board		X				B.B. Board		X	
Center Board		X				Board		X	
Board		X				Strip		X	
Cover Pad		X				Strip		X	
						B.B. Pad		X	

Product Code

Part # 4448
Style Case VINYL FOLDER

Sheet Size 12 x 12

Cap. 3/4

Die No. 4380

Order No. 964826

Plate

Customer

INDUSTRIAL TRAINING CORP.

Metal
Total Vinyl
Quantity 2000
Date 2-15-90
Type Corners
Radius
Completed

Gauge	Thick
Tear Seal .014	1/16
Bar Seal	
Bar Seal	

No. of Feet
Tear Seal
Bar Seal
Bar Seal

S2C - B.P.C.C. 2-15-90
CHEN

KPV

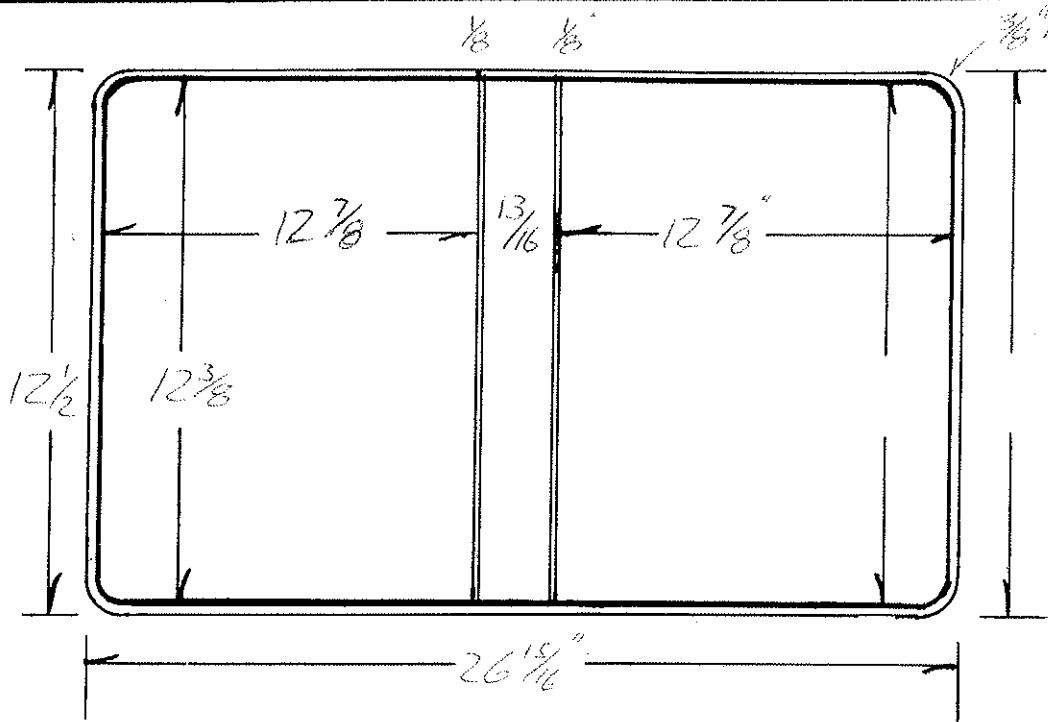

Code	Ga.	# PCS	Size	Out	Cutting Specs	Code	Ga.	# PCS	Size	Out	Cutting Specs
Cover Mat.			13 1/4 X 27 3/4	15	1	Lining Mat.			13 1/4 X 27 3/4	15	1
Cover Mat			X			Lining Mat.			X		
Vert. Pckt.			X			Horz. Pckt.			X		
Vert. Pckt.			X			Horz. Pckt.			X		
Pocket	IBC		13 1/4 X 12 5/8	15	1	Pocket			X		
Label Holder			X			Card Holder	Frosted Clear		4 3/8 X 1 1/2	8	1
Material			X			Material			X		
Material			X			Material			X		
Material			X			Material			X		
F.C. Board			12 9/32 X 12 25/32	120	1	B.C. Board			X		
B.G. Board			12 9/32 X 12 27/32	120	1	B.B. Board			12 9/32 X 23/32	120	1
Center Board			X			Board			12 5/16 X 23/32	100	1
Board			12 5/16 X 12 13/16	100	2	Strip			X		
Cover Pad			X			Strip			X		
						B.B. Pad			X		

Product Code

Style Case

Sheet Size $7\frac{3}{8}$ X $3\frac{3}{8}$ Cap. $\frac{3}{8}$

Die No. 4405

Order No. 965203.1

Plate

Customer

ALBERT-KELLY PRINTING CO.

Metal
Total Vinyl
Quantity 500
Date 4-5-90
Type Corners
Radius $\frac{3}{8}$ "
Completed

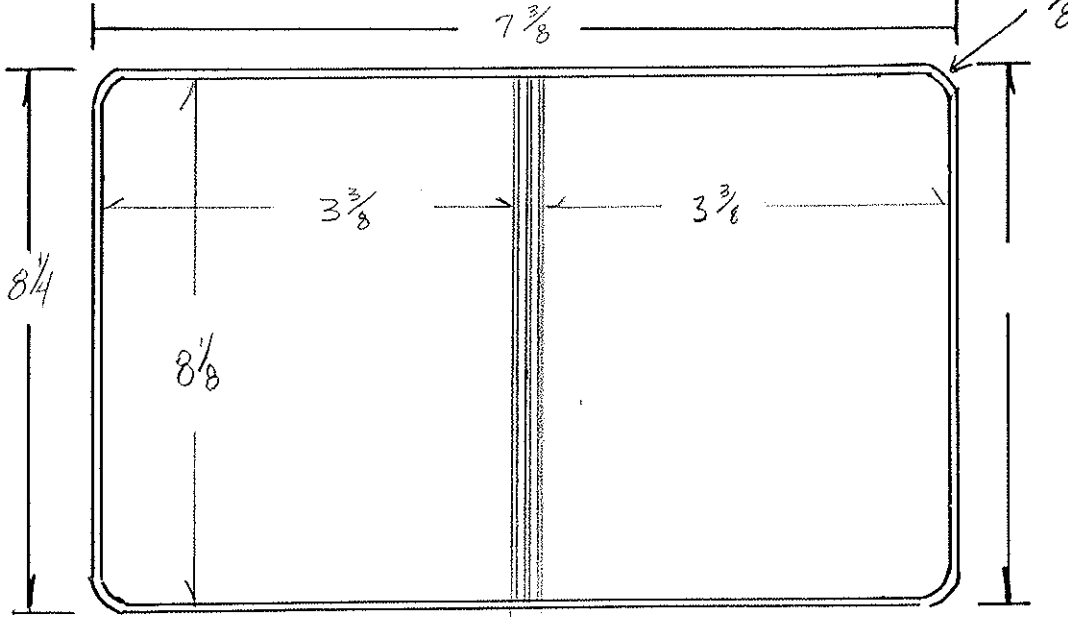

	Gauge	Thick
Tear Seal	14	1/16"
Bar Seal	253	1/8"
Bar Seal	178	3/16"

	No. of Feet
Tear Seal	
Bar Seal	
Bar Seal	

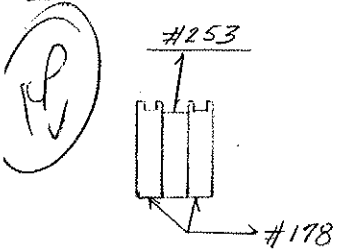

Code		Cutting Specs				Code		Cutting Specs			
		Ga.	Pcs	Size	Out			Ga.	Pcs.	Size	Out
Cover Mat.	9 X $8\frac{1}{8}$	15	1		5	Lining Mat.	9 X $8\frac{1}{8}$	15	1		5
Cover Mat.	X					Lining Mat.	X				
Vert. Pckt.	X					Horz. Pckt.	X				
Vert. Pckt.	9 X $3\frac{3}{8}$	8	2			Horz. Pckt.	X				
Pocket	X					Pocket	X				
Label Holder	X					Card Hlder	X				
Material	X					Material	X				
Material	X					Material	X				
Material	X					Material	X				
F.C. Board $\frac{1}{16}$	$8\frac{1}{16}$ X $3\frac{5}{16}$	100	1			B.C. Board	X				
B.C. Board $\frac{1}{16}$	$8\frac{1}{16}$ X $3\frac{5}{16}$	100	1			B.B. Board	X				
Center Board	X					Board	X				
Board	X					Strip	X				
Cover Pad	X					Strip	X				
						B.B. Pad	X				

Product Code

Style Case VINYL FOLDER

Sheet Size 9 3/8 X 6 1/8 Cap. 1 3/16 Die No. 4418-A Order No. 965444 Plate

PERIMETER PRINTING

Customer
Metal
Total Vinyl
Quantity <u>1000</u>
Date
Type Corners
Radius
Completed

	Gauge	Thick
Tear Seal	#014	1/16
Bar Seal	#102	1/16
Bar Seal	#254	3/32

	No. of Feet
Tear Seal	
Bar Seal	
Bar Seal	

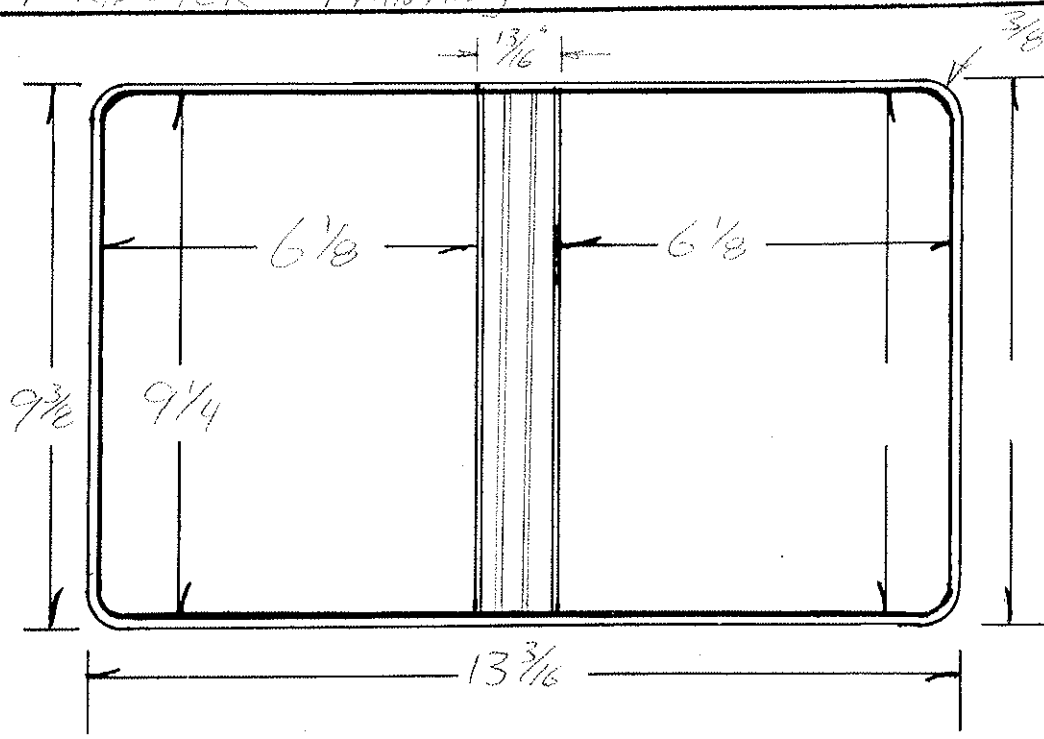

Size BK
CPV

Code	Ga.	PCS	Cutting Specs		Code	Ga.	Pcs.	Cutting Specs	
			Size	Out				Size	Out
Cover Mat.			$10 \frac{1}{4}$ X	14	Lining Mat.			$10 \frac{1}{4}$ X	14
Cover Mat			X		Lining Mat.			X	
Vert. Pckt.			X		Horz. Pckt.			X	
Vert. Pckt.			X		Horz. Pckt.			X	
Pocket			X		Pocket			X	
Label Holder			X		Card Holder			X	
Material			X		Material	012		$4 \frac{1}{4}$ X	$6 \frac{3}{4}$
Material			X		Material	4418-B		$10 \frac{1}{4}$ X	$6 \frac{3}{4}$
Material			X		Material			X	
F.C. Board			$9 \frac{5}{32}$ X	$6 \frac{1}{32}$	B.C. Board			X	
B.G. Board			$9 \frac{5}{32}$ X	$6 \frac{1}{32}$	B.B. Board			X	
Center Board			X		Board			X	
Board			X		Strip			X	
Cover Pad			X		Strip			X	
					B.B. Pad			X	

Product Code

Style Case **VINYL FOLDER**

~~Sheet~~ Size **9** x **11⁷/₈** Cap. **7/16** Die No. **4427** Order No. **965603** Plate

Customer

MICRO-MOTION FLOW METERS

Metal
Total Vinyl
Quantity 500
Date 5-17-90
Type Corners
Radius 1/32"
Completed

	Gauge	Thick
Tear Seal	.014	1/16
Bar Seal	#178	3/16"
Bar Seal		

	No. of Feet
Tear Seal	
Bar Seal	
Bar Seal	

SIZE - B. PACC
CHECK - (K) ✓

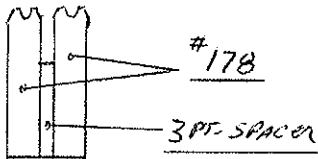
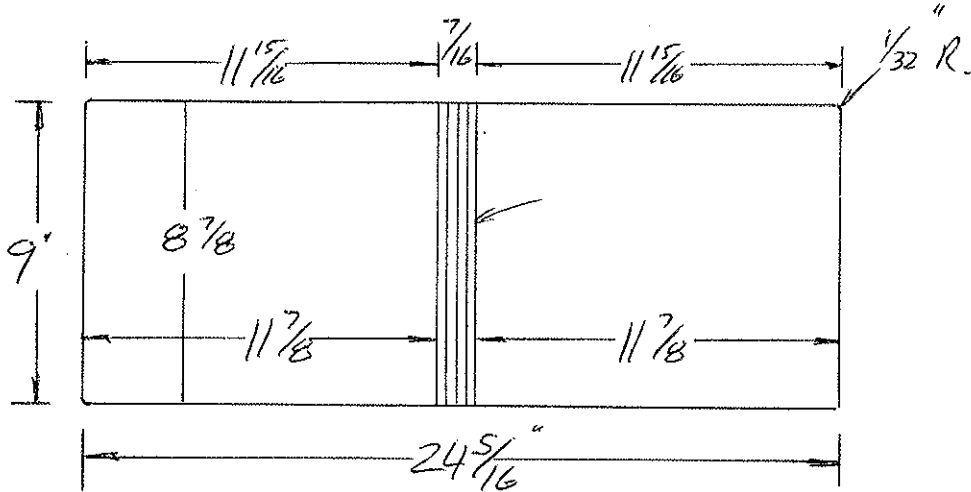

Code		Ga.	# PCS	Size	Out	Cutting Specs	Code		Ga.	# Pcs.	Size	Out	Cutting Specs.
Cover Mat.	9 3/4 x 25 1/8	15	1				Lining Mat.	9 3/4 x 25 1/8	15	1			
Cover Mat	X						Lining Mat.	X					
Vert. Pckt.	X						Horz. Pckt.	X					
Vert. Pckt.	X						Horz. Pckt.	5 3/8 x 25 1/8	15	1			
Pocket	X						Pocket	X					
Label Holder	X						Card Holder	X					
Material	X						Material	X					
Material	X						Material	X					
Material	X						Material	X					
F.C. Board	8 25/32 x 11 25/32	18	1				B.C. Board	X					
B.C. Board	8 25/32 x 11 25/32	18	1				B.B. Board	X					
Center Board	X						Board	X					
Board	X						Strip	X					
Cover Pad	X						Strip	X					
							B.B. Pad	X					

Product Code

Style Case Vinyl Folder

Sheet Size 11 x 8 1/2 Cap. 3/4 Die No. 4499

Order No. 966252.1 Plate

Customer COLAD GROUP

Metal
Total Vinyl
Quantity
Date
Type Corners
Radius
Completed

NATURAL EDGE .014 REVERSED

1/8 #253 EVERLAST HINGE COARSE

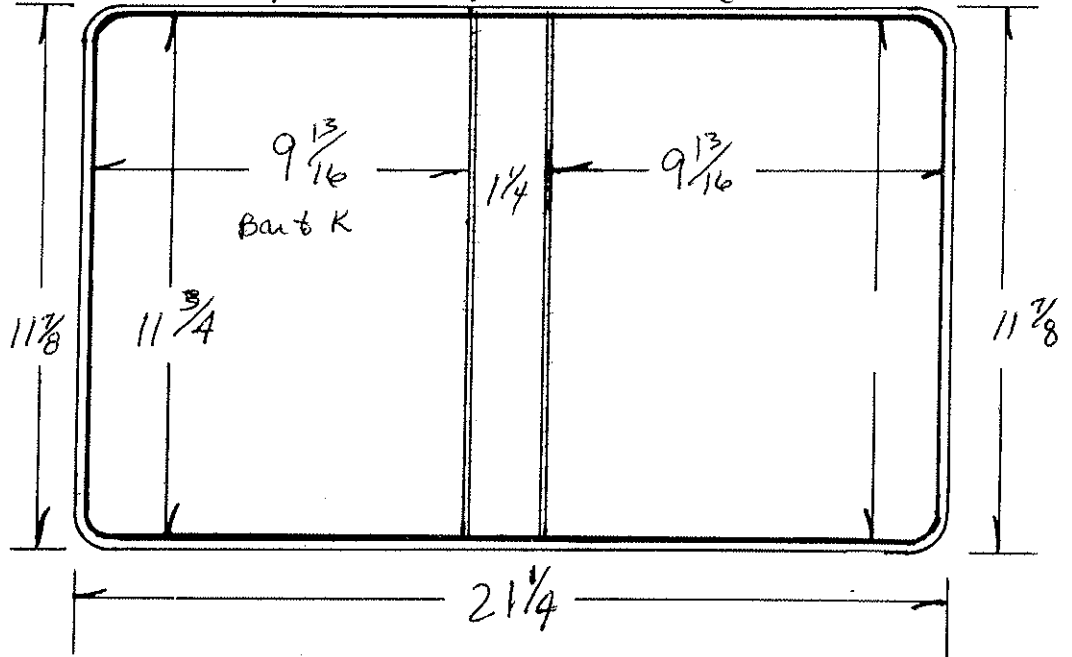

Gauge	Thick
Tear Seal .014	1/16
Bar Seal 253	1/8

No. of Feet
Tear Seal
Bar Seal
Bar Seal

Drawn by KP
Check by BP calc only

Code		Cutting Specs				Code		Cutting Specs			
		Ga.	# PCS	Size	Out			Ga.	# Pcs.	Size	Out
Cover Mat.	12 5/8 X 22		1			Lining Mat.	12 5/8 X 22		1		
Cover Mat. Padded	12 7/8 X 22 1/4					Lining Mat.	X				
Vert. Pckt.	12 5/8 X 9 1/4		1			Horz. Pckt.	5 3/8 X 10 1/4		1		
Vert. Pckt.	X					Horz. Pckt.	X				
Pocket	X					Pocket	X				
Label Holder	X					Card Hlder	X				
Material	X					Material	X				
Material	X					Material	X				
Material	X					Material	X				
F.C. Board Padded	11 5/8 X 9 1/16	100	1			B.C. Board	X				
B.G. Board Padded	11 5/8 X 9 1/16	100	1			B.B. Board	11 5/8 X 1 5/32	100	1		
Center Board	X					Board	X				
Board	X					Strip	X				
Cover Pad	X					Strip	X				
						B.B. Pad	X				

Product Code

Style Case VINYL FOOD/VRB

Sheet Size 12 X 9 1/2 Cap. 1/2

Die No. 4585

Order No. 967014

Plate

Customer

CUNNINGHAM, BLACK & FARLEY

Metal
Total Vinyl
Quantity 1,000
Date 11-7-90
Type Corners
Radius 3/8"
Completed

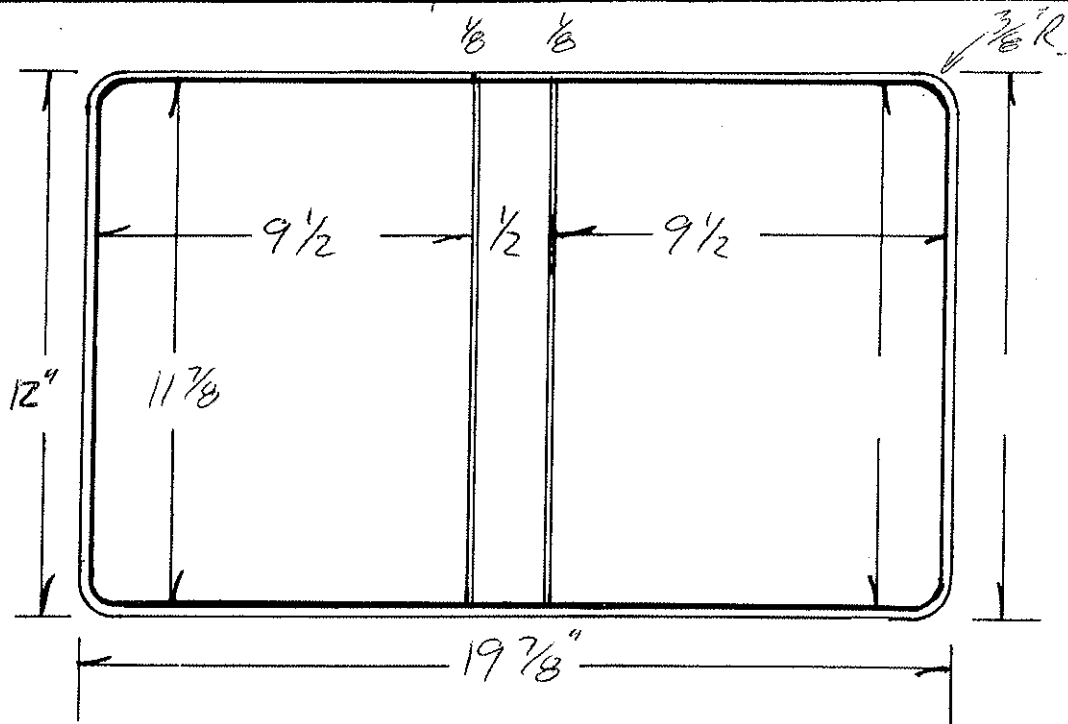

	Gauge	Thick
Tear Seal	1014	1/16"
Bar Seal	#253	1/8"
Bar Seal		

	No. of Feet
Tear Seal	
Bar Seal	
Bar Seal	

SIZE - B.P.
 Check - *(Signature)*

Code	Ga.	# PCS	Cutting Specs		Code	Ga.	# Pcs.	Cutting Specs	
			Size	Out				Size	Out
Cover Mat.		12 3/4 X 20 5/8	14	1	Lining Mat.		12 3/4 X 20 5/8	14	1
Cover Mat		X			Lining Mat.		X		
Vert. Pckt.		X			Horz. Pckt.		X		
Vert. Pckt.		X			Horz. Pckt.		5 7/8 X 20 5/8	14	1
Pocket		X			Pocket		X		
Label Holder		X			Card Hlder	-	X		
Material		X			Material		X		
Material		X			Material		X		
Material		X			Material		X		
F.C. Board		11 25/32 X 9 13/32	100	1	B.C. Board		X		
B.C. Board		11 25/32 X 9 13/32	100	1	B.B. Board		11 25/32 X 3/8"	100	1
Center Board		X			Board		X		
Board		X			Strip		X		
Cover Pad		X			Strip		X		
					B.B. Pad		X		

Triab Die 4671HB

Product Code

Style Case DISKETTE FOLDER

ACTUAL Sheet Size 9 x 6

Cap. 19/32

Die No. 4599-A-B-C

Order No. 967222

Plate

R.R. DONNELLEY & SONS CO.

Customer

Metal
Total Vinyl
Quantity 12
Date 11-27-90
Type Corners
Radius 3/8"
Completed

	Gauge	Thick
Tear Seal	012	1/16"
Bar Seal	#102 X 5	
Bar Seal		

	No. of Feet
Tear Seal	
Bar Seal	
Bar Seal	

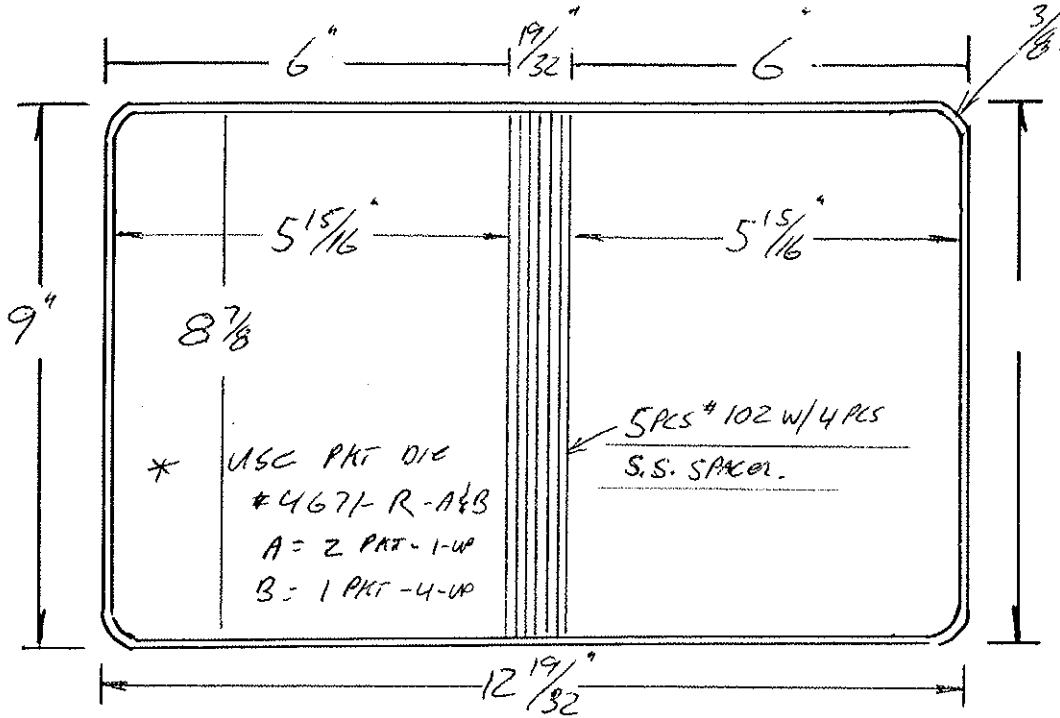

SIZE - B.P.
CHECK KPV

1/16" SPACE

Code	Ga.	PCS	Cutting Specs		Code	Ga.	Pcs.	Cutting Specs	
			Size	Out				Size	Out
Cover Mat.	9 3/4	12	13 3/8	1	Lining Mat.	9 3/4	12	13 3/8	1
Cover Mat			X		Lining Mat.			X	
Vert. Pckt.	9 3/4	8	5 3/4	1	A-Horz. Pckt.	8	8	8	1
Vert. Pckt.			X		B-Horz. Pckt.	8	14 7/8	8	1
Pocket			X		Pocket			X	
Label Holder			X		Card Holder			X	
Material			X		Material			X	
Material			X		Material			X	
Material			X		Material			X	
F.C. Board	8 25/32	50	5 27/32	1	B.C. Board			X	
B.C. Board	8 25/32	50	5 27/32	1	B.B. Board			X	
Center Board			X		Board			X	
Board			X		Strip			X	
Cover Pad			X		Strip			X	
Unlined Board	8 25/32		12 3/8	with 1/16" flap	B.B. Pad			X	