

Stock

Product Code

Style Case *CLIP PAD HOLDER*

Sheet Size *11" x 8 1/2"* Cap. *3/4"*

Die No. *481-A*

Order No.

Plate

Customer *STOCK*

Cutting Die *481-B*

Metal
Total Vinyl
Quantity
Date <i>4-4-84</i>
Type Corners <i>R/A</i>
Radius <i>3/8"</i>
Completed

	Gauge	Thick
Tear Seal	<i>16</i>	<i>3/32</i>
Bar Seal		<i>3/4</i>
Bar Seal		

	No. of Feet
Tear Seal	
Bar Seal	
Bar Seal	

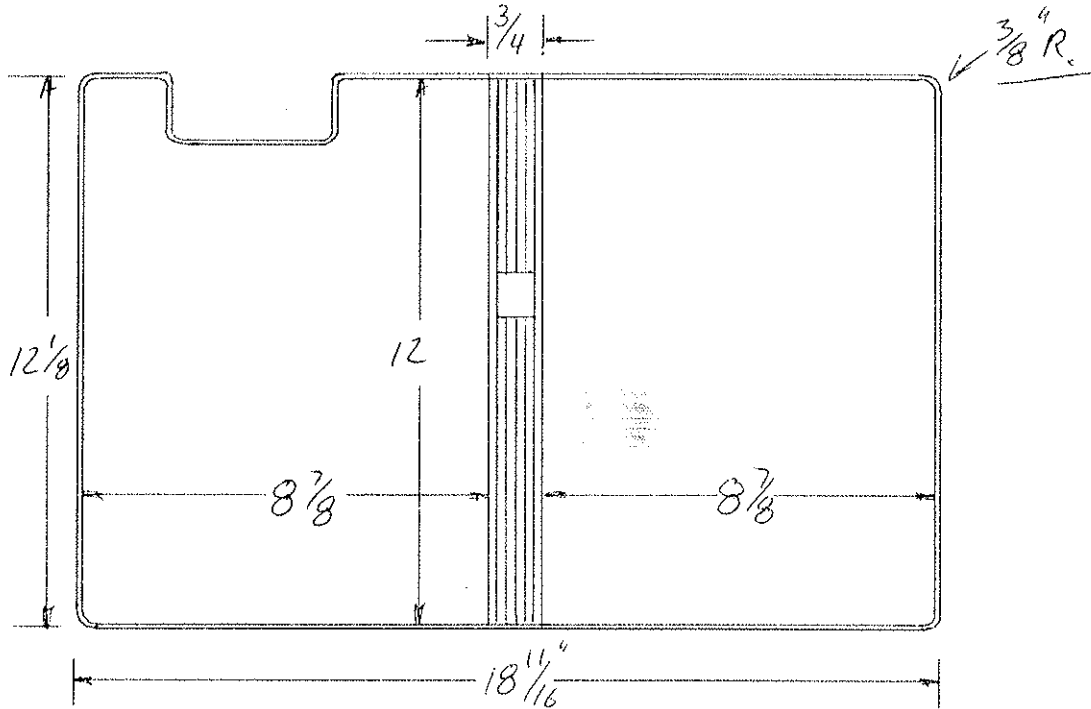

Code	Ga.	Pcs	Cutting Specs		Code	Ga.	Pcs	Cutting Specs	
			Size	Out				Size	Out
Cover Mat.	<i>13</i>	<i>20</i>	<i>15</i>	<i>1</i>	Lining Mat.	<i>14</i>	<i>20 1/2</i>	<i>15</i>	<i>1</i>
Cover Mat		X			Lining Mat.		X		
Vert. Pckt.	<i>13</i>	<i>5 3/8</i>	<i>15</i>	<i>1</i>	Horz. Pckt.		X		
Vert. Pckt.		X			Horz. Pckt.		X		
Pocket	<i>DIAGONAL</i>	<i>10</i>	<i>10</i>	<i>15</i>	<i>1/2</i>	Pocket		X	
Label Holder		X			Card holder		X		
Material		X			Material		X		
Material		X			Material		X		
Material	<i>3 out die x cut</i>				Material		X		
F.C. Board	<i>13</i>	<i>19</i>	<i>(2-out)</i>		B.C. Board		X		
B.C. Board	<i>120</i>	<i>11 29/32</i>	<i>8 25/32</i>	<i>1</i>	B.B. Board		X		
Center Board		X			Board		X		
Board	<i>100</i>	<i>11 15/16</i>	<i>8 13/16</i>		Strip		X		
Cover Pad		X			Strip		X		
					B.B. Pad		X		

*(Grain - side up)*

*Code new-DIE CUT.*

Product Code

Style Case *Tritold Pad holder*

Sheet Size *14 1/2 X 8 1/2* Cap.

*as sample*

Die No. *2726*

Order No. *16565-4*

Plate

Customer

*Angel Publications*

Metal
Total Vinyl <i>.030</i>
Quantity <i>1</i>
Date
Type Corners <i>Rd.</i>
Radius <i>3/32 + 1/4</i>
Completed

	Gauge	Thick
Tear Seal	<i>.016</i>	<i>732</i>
Bar Seal	<i>178</i>	<i>3/16</i>
Bar Seal		

	No. of Feet
Tear Seal	
Bar Seal	
Bar Seal	

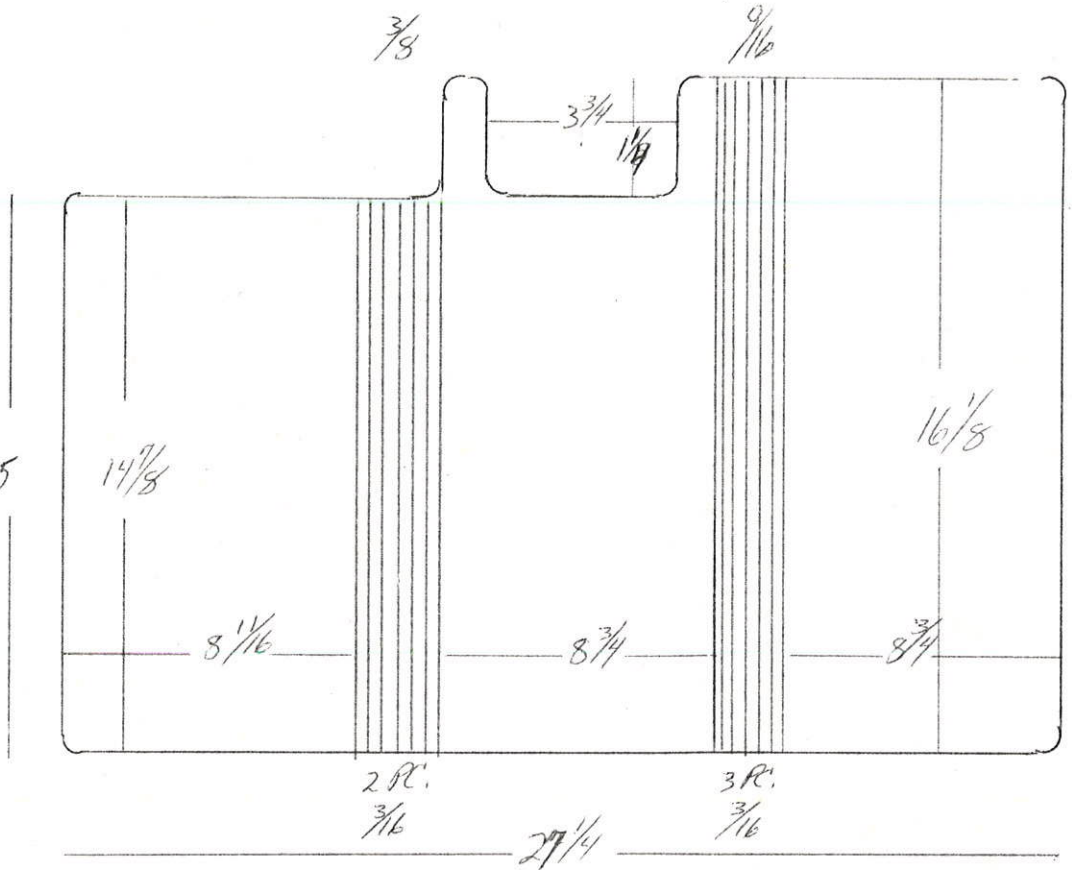

Code	Ga.	#	Cutting Specs		Code	Ga.	#	Cutting Specs	
			Size	Out				Size	Out
Cover Mat.			$16 \frac{7}{8} \times 28$	1	Lining Mat.			$16 \frac{7}{8} \times 28$	1
Cover Mat.			X		Lining Mat.			X	
Vert. Pckt.			X		Horz. Pckt.			X	
Vert. Pckt.			X		Horz. Pckt.			X	
Pocket			X		Pocket			X	
Label Holder			X		Card Holder			X	
Material			X		Material			X	
Material			X		Material			X	
Material			X		Material			X	
B.C. Board			$16 \times 8 \frac{5}{8}$	1	B.C. Board			$16 \times 8 \frac{5}{8}$	1
B.C. Board			$14 \frac{3}{4} \times 8 \frac{9}{16}$	1	B.B. Board			X	
Center Board			X		Board			X	
Board			X		Velcro Fastener Strip			$2 \times 1 \frac{3}{8}$	1
Cover Pad			X		Strip			X	
					B.B. Pad			X	

Product Code

Style Case *clip Pad holder*

Sheet Size *17 X 11*

Cap. *1/2*

Die No. *3625*

Order No. *953008*

Plate

Customer

*Southern Business Forms Inc.*

Metal
Total Vinyl <i>.030</i>
Quantity <i>100</i>
Date <i>10-2-26</i>
Type Corners <i>RS</i>
Radius <i>1/4</i>
Completed

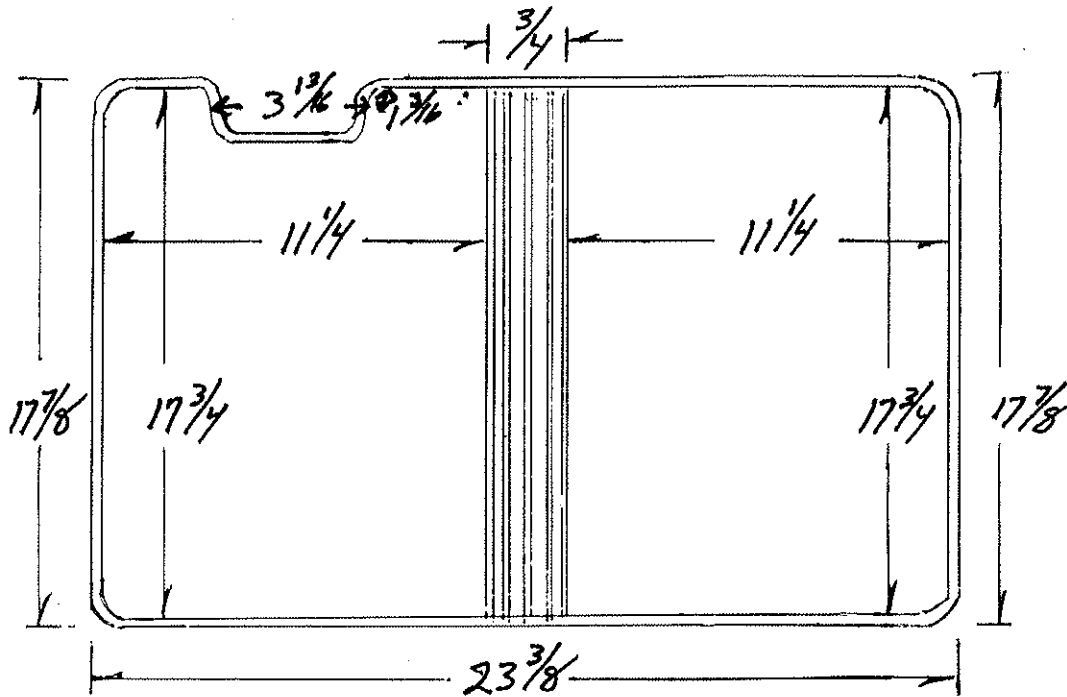

	Gauge	Thick
Tear Seal	<i>.016</i>	<i>3/32</i>
Bar Seal		
Bar Seal		

	No. of Feet
Tear Seal	
Bar Seal	
Bar Seal	

*B.B. to be 3 pc.  
3/16 grooved up  
4 pc. .028 lead*

Code	Ga.	PCS	Cutting Specs		Code	Ga.	Pcs.	Cutting Specs	
			Size	Out				Size	Out
Cover Mat.		<i>1</i>	<i>18 1/2 X 24 1/8</i>		Lining Mat.		<i>1</i>	<i>18 1/2 X 24 1/8</i>	
Cover Mat			X		Lining Mat.			X	
Vert. Pckt.			X		Horz. Pckt.			X	
Vert. Pckt.			X		Horz. Pckt.			X	
Pocket					Pocket			X	
Label Holder			X		Card Holder			X	
Material			X		Material			X	
Material			X		Material			X	
Material			X		Material			X	
F.C. Board		<i>1</i>	<i>18 1/2 X 12 1/4</i>		B.C. Board		<i>1</i>	<i>17 21/32 X 11 5/32</i>	
B.C. Board			X		B.B. Board			X	
Center Board			X		Board			X	
Board			X		Strip			X	
Cover Pad			X		Strip			X	
					B.B. Pad			X	

Product Code

Style Case Pad Holder

Sheet Size Per Sample Cap.

Die No. 3944

Order No. 957498

Plate

Customer T. van Allen

Metal
Total Vinyl
Quantity
Date
Type Corners <u>Ad</u>
Radius <u>3/32</u>
Completed

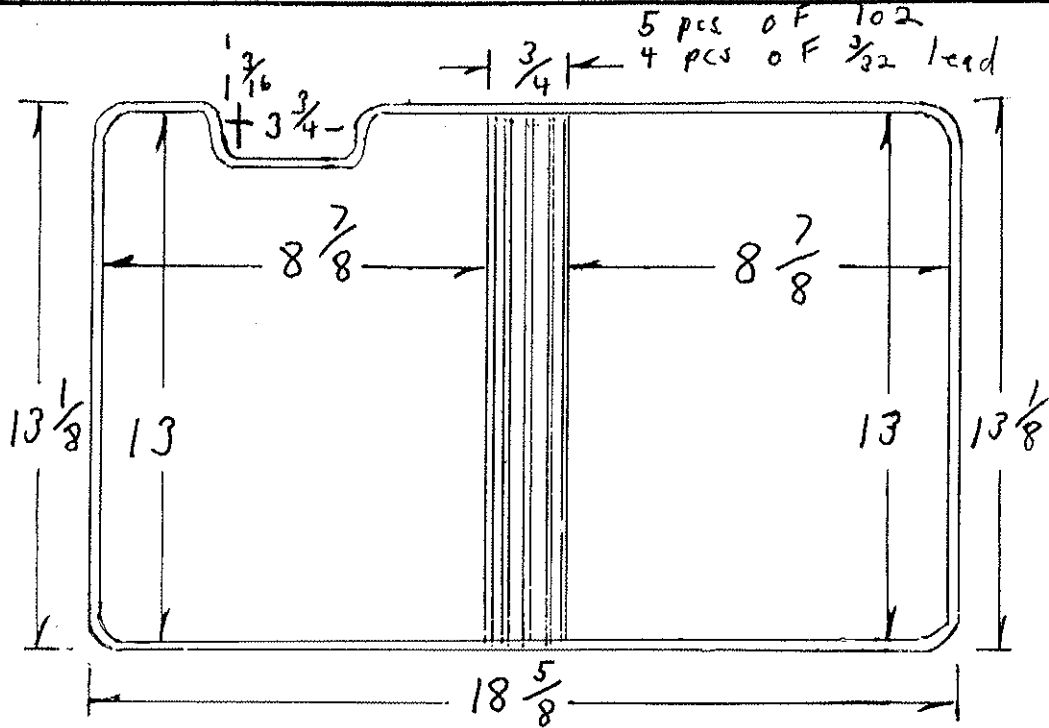

	Gauge	Thick
Tear Seal	<u>16</u>	<u>8/32</u>
Bar Seal	<u>102</u>	<u>3/32</u>
Bar Seal		

	No. of Feet
Tear Seal	
Bar Seal	
Bar Seal	

Code	Cutting Specs				Code	Cutting Specs				
	Ga.	Pcs.	Size	Out		Ga.	Pcs.	Size	Out	
Cover Mat.			$13 \frac{3}{4} \times 19 \frac{3}{8}$	1	Lining Mat.			$13 \frac{3}{4} \times 19 \frac{3}{8}$	1	
Cover Mat.			X		Lining Mat.			X		
Vert. Pckt.			X		Horz. Pckt.			$5 \frac{3}{8} \times 9 \frac{3}{4}$	1	
Vert. Pckt.			X		Horz. Pckt.			X		
Pocket			X		Pocket			X		
Label Holder			X		Card Hlder			X		
Material			X		Material			X		
Material			X		Material			X		
Material			X		Material			X		
F.C. Board			$12 \frac{29}{32} \times 8 \frac{25}{32}$	120	1	B.C. Board			$12 \frac{29}{32} \times 8 \frac{25}{32}$	120
B.C. Board	Diecut		$13 \frac{1}{16} \times 19 \frac{1}{8}$	100	2	B.B. Board			$12 \frac{15}{16} \times 8 \frac{13}{16}$	100
Center Board			(Die $\approx$ up)			Board			X	
Board			X		Strip			$\frac{3}{4} \times 1 \frac{1}{4}$	1	
Cover Pad			X		Strip			X		
					B.B. Pad			X		

Product Code

Style Case *Pad holder*

Sheet Size *Per* X Sample Cap.

Die No. *3945*

Order No. *957802*

Plate

Customer *Evan Allen*

Metal
Total Vinyl
Quantity
Date
Type Corners <i>Rd</i>
Radius <i>3/32</i>
Completed

	Gauge	Thick
Tear Seal	<i>16</i>	<i>3/32</i>
Bar Seal	<i>253</i>	<i>1/2</i>
Bar Seal		

	No. of Feet
Tear Seal	
Bar Seal	
Bar Seal	

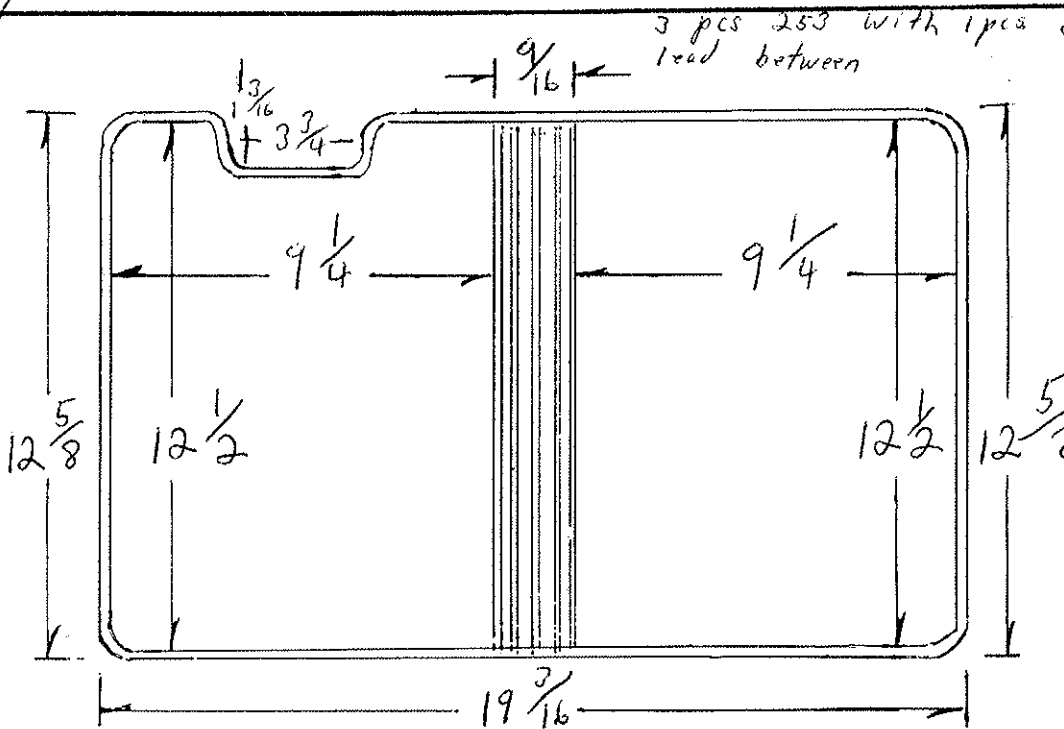

Code	Ga.	# PCS	Cutting Specs		Code	Ga.	# Pcs.	Cutting Specs	
			Size	Out				Size	Out
Cover Mat.		<i>1</i>	$13 \frac{1}{4} \times 19 \frac{15}{16}$		Lining Mat.		<i>1</i>	$13 \frac{1}{4} \times 19 \frac{15}{16}$	
Cover Mat			X		Lining Mat.			X	
Vert. Pckt.			X		Horz. Pckt.			X	
Vert. Pckt.			X		Horz. Pckt.			X	
Pocket			X		Pocket			X	
Label Holder			X		Card Holder			X	
Material			X		Material			X	
Material			X		Material			X	
Material			X		Material			X	
F.C. Board		<i>1</i>	<del><math>12 \frac{1}{4} \times 19 \frac{15}{16}</math></del>	<i>1</i>	B.C. Board		<i>1</i>	<del><math>12 \frac{1}{4} \times 19 \frac{15}{16}</math></del>	
B.G. Board			<i>Die Cut Bd</i>		B.B. Board			X	
Center Board			<i>Die #3945 A</i>		Board			X	
Board			<i>Both Panels</i>		Strip			X	
Cover Pad			$13 \frac{3}{8} \times 20$		Strip			X	
					B.B. Pad			X	

Product Code

CLIP-PADHOLDER  
Style Case

Sheet Size  $7\frac{3}{4}$  x  $8\frac{1}{2}$  Cap.  $\frac{3}{4}$  Die No. 4273 Order No. 963497 Plate

Customer

REPUBLIC FINANCIAL SERVICES

Metal
Total Vinyl
Quantity 500
Date 9-14-69
Type Corners
Radius $\frac{3}{8}$ "
Completed

	Gauge	Thick
Tear Seal	.016	$\frac{1}{16}$ "
Bar Seal		
Bar Seal		

	No. of Feet
Tear Seal	
Bar Seal	
Bar Seal	

REQUIRES CUTTING DIE.

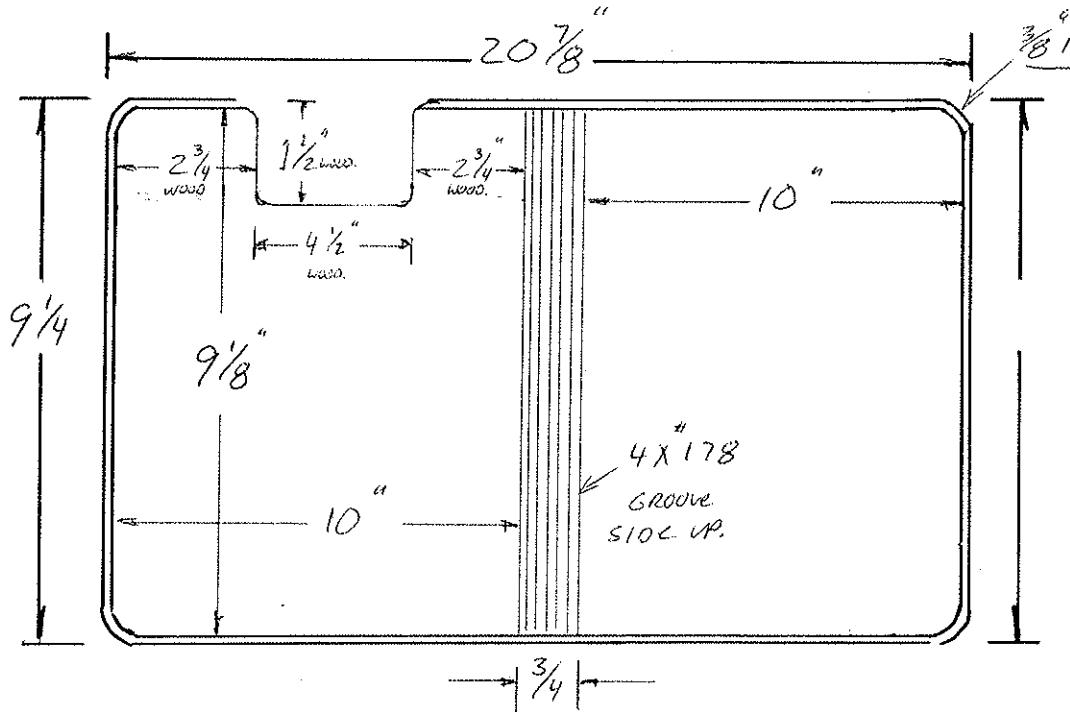

Code	Ga.	Pcs.	Cutting Specs		Code	Ga.	Pcs.	Cutting Specs	
			Size	Out				Size	Out
Cover Mat.		10	X	$21\frac{3}{4}$		15	1		
Cover Mat.		X			Lining Mat.		10	X	$21\frac{3}{4}$
Vert. Pckt.		X			Lining Mat.		X		
Vert. Pckt.		X			Horz. Pckt.		X		
Pocket		X			Horz. Pckt.		$6\frac{3}{8}$	X	$10\frac{1}{2}$
Label Holder		X			Pocket		X		
Material		X			Card Hlder		X		
Material		X			Material		X		
Material		X			Material		X		
F.C. Board	die cut	10	X	11	Material		X		
B.C. Board		$9\frac{1}{32}$	X	$9\frac{29}{32}$	B.C. Board		X		
Center Board		X			B.B. Board		X		
Board		X			Board		X		
Cover Pad		X			Strip		X		
					Strip		X		
					B.B. Pad		X		

Product Code

Style Case 3-PANEL PAD HOLDER

Sheet Size 11 x 8 1/2 Cap. 1/2

Die No. 4276

Order No. 963480

Plate

DIGITAL MATRIX SYSTEMS

Customer

Metal
Total Vinyl
Quantity <u>750</u>
Date <u>9-12-89</u>
Type Corners <u>RND</u>
Radius <u>3/8"</u>
Completed

	Gauge	Thick
Tear Seal	<u>016</u>	<u>3/32</u>
Bar Seal		
Bar Seal		

	No. of Feet
Tear Seal	
Bar Seal	
Bar Seal	

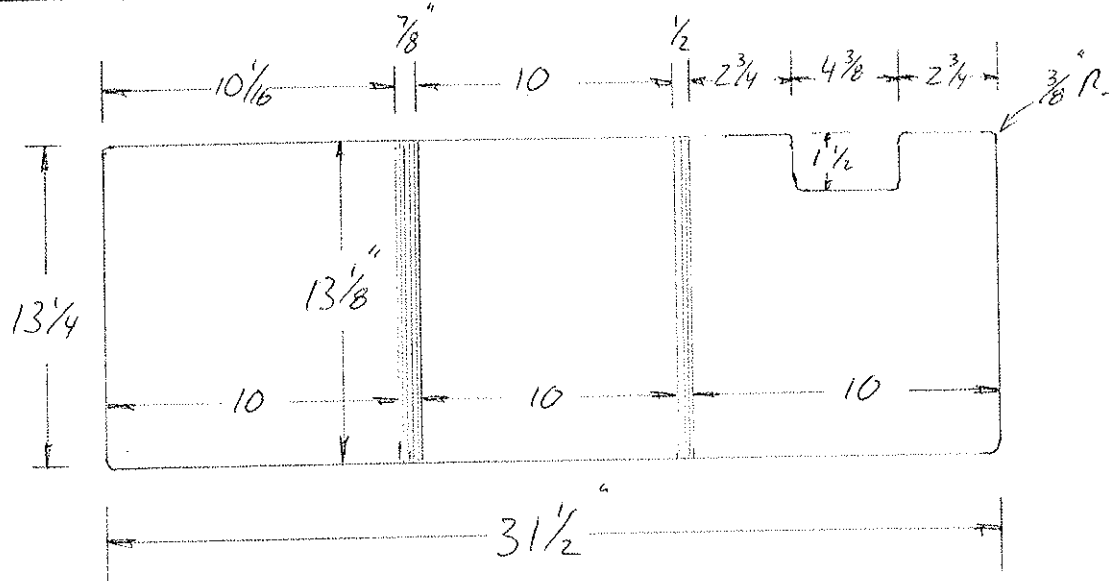

REQUIRES 2 CUTTING DIES

Code	Ga.	# PCS	Cutting Specs.		Code	Ga.	# Pcs.	Cutting Specs.					
			Size	Out				Size	Out				
Cover Mat.		<u>14</u>	<u>X</u>	<u>32 1/2</u>	<u>15</u>	<u>1</u>	Lining Mat.	<u>012 cut</u>	<u>14</u>	<u>X</u>	<u>32 1/2</u>	<u>15</u>	<u>1</u>
Cover Mat			<u>X</u>		Lining Mat.			<u>X</u>					
Vert. Pckt.			<u>X</u>		Horz. Pckt.	<u>3"</u>	<u>3 3/8</u>	<u>X</u>	<u>10 1/4</u>	<u>8</u>	<u>1</u>		
Vert. Pckt.			<u>X</u>		Horz. Pckt.	<u>5"</u>	<u>5 3/8</u>	<u>X</u>	<u>10 1/4</u>	<u>15</u>	<u>1</u>		
Pocket			<u>X</u>		Pocket			<u>X</u>					
Label Holder	<u>OPEN</u>		<u>X</u>		Card Hlder			<u>X</u>					
Material	<u>C.O.L.</u>		<u>11 3/4</u>	<u>X</u>	<u>10 1/2"</u>	<u>8</u>	<u>1</u>	Material			<u>X</u>		
Material			<u>X</u>		Material			<u>X</u>					
Material			<u>X</u>		Material			<u>X</u>					
F.C. Board		<u>13 1/32</u>	<u>X</u>	<u>9 29/32</u>	<u>100</u>	<u>1</u>	B.C. Board			<u>X</u>			
B.C. Board	<u>012 cut.</u>	<u>14</u>	<u>X</u>	<u>11</u>	<u>100</u>	<u>1</u>	B.B. Board			<u>X</u>			
Center Board		<u>13 1/32</u>	<u>X</u>	<u>9 29/32</u>	<u>100</u>	<u>1</u>	Board			<u>X</u>			
Board			<u>X</u>		Strip			<u>X</u>					
Cover Pad			<u>X</u>		Strip			<u>X</u>					
					B.B. Pad			<u>X</u>					

Product Code

Style Case PAD HOLDER

Sheet Size 8 X 5

Cap. 3/4" Die No. 4303

Order No. 963664

Plate

Customer

SYLVAN LEARNING CENTER

Metal
Total Vinyl
Quantity <u>425</u>
Date <u>10-18-65</u>
Type Corners
Radius
Completed <u>10-19-65 B.P. RET</u>

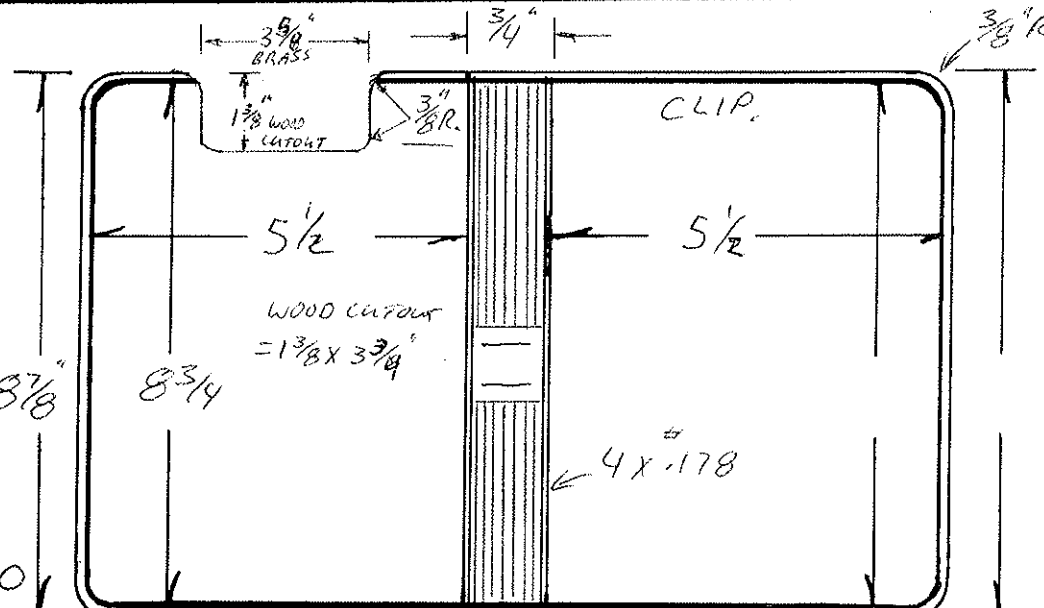

Gauge	Thick
Tear Seal	.014
Bar Seal	#178
Bar Seal	3/16"

No. of Feet
Tear Seal
Bar Seal
Bar Seal

SIZE BY: B.P. 10-20

CHECK BY: [Signature]

REQUIRES (1) BOARD DIE  
(1) LINING DIE

HOLDS STANDARD 5X8 LEGAL PAD  
PER L.P. 10-18-81 B.P.

CUTTING

DIES SEE ATTACHED

Code	Ga.	Pcs	Cutting Specs		Code	Ga.	Pcs	Cutting Specs	
			Size	Out				Size	Out
Cover Mat.	9 5/8 X 12 5/8	15	1		Lining Mat. DIE CUT	10 5/8 X 13 5/8	15	1	
Cover Mat.	X				Lining Mat.	X			
Vert. Pckt.	X				Horz. Pckt.	X			
Vert. Pckt.	X				Horz. Pckt. 3 1/2"	3 7/8 X 6	15	1	
Pocket	X				Pocket	X			
Label Holder	X				Card Holder	X			
Material	X				Material	X			
Material	X				Material	X			
Material	X				Material	X			
F.C. Board DIE CUT	9 1/2 X 6 1/2	100	1		B.C. Board	X			
B.G. Board	8 2 1/32 X 5 13/32	100	1		B.B. Board	X			
Center Board	X				Board	X			
Board	X				Strip	X			
Cover Pad	X				Strip	X			
					B.B. Pad	X			



Product Code

Style Case CLIP-PAD HOLDER

Sheet Size 14 x 8 1/2 Cap. 3/4 Die No. 4420-A Order No. 965412 Plate

Customer	<u>HOUSTON INDEPENDENT SCHOOL DIST.</u>	
Metal		
Total Vinyl		
Quantity	<u>300</u>	
Date	<u>5-4-90</u>	
Type Corners		
Radius	<u>3/16"</u>	
Completed		

	Gauge	Thick
Tear Seal	<u>#014</u>	<u>1/16</u>
Bar Seal	<u>#178</u>	<u>3/16"</u>
Bar Seal		

	No. of Feet
Tear Seal	
Bar Seal	
Bar Seal	

SIZE - B. Plate  
7.000 - KPV

for slit use  
Die 4420

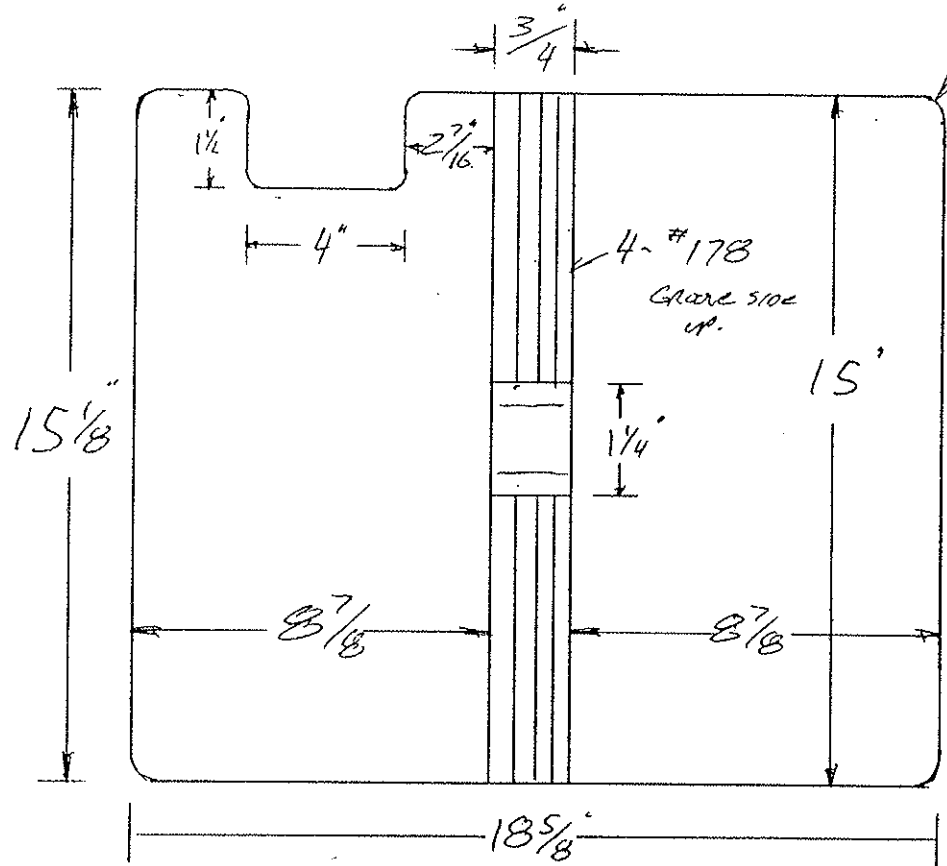

TOP VIEW OF DIE

Code	Ga.	PCS	Cutting Specs		Code	Ga.	Pcs.	Cutting Specs										
			Size	Out				Size	Out									
Cover Mat.		<u>16</u>	<u>X</u>	<u>19 1/2</u>		<u>15</u>	<u>1</u>			Lining Mat.		<u>16</u>	<u>X</u>	<u>19 1/2</u>	<u>15</u>	<u>1</u>		
Cover Mat.			X		Lining Mat.			X		Lining Mat.			X					
Vert. Pckt.			X		Horz. Pckt.			X		Horz. Pckt.			X					
Vert. Pckt.			X		Horz. Pckt.			X		Horz. Pckt.			X					
Pocket			X		Pocket	<u>DIAB</u>		<u>12 1/2</u>	<u>X</u>	<u>9 1/4</u>	<u>15</u>	<u>1</u>						
Label Holder			X		Card Holder					<u>X2-OUT</u>								
Material			X		Material			X		Material			X					
Material			X		Material			X		Material			X					
Material			X		Material			X		Material			X					
F.C. Board	<u>012</u> <u>CLR</u>		<u>16</u>	<u>X</u>	<u>10</u>	<u>100</u>	<u>1</u>			B.C. Board			X					
B.C. Board			<u>14 29/32</u>	<u>X</u>	<u>8 25/32</u>	<u>100</u>	<u>1</u>			B.B. Board			X					
Center Board			X		Board			X		Board			X					
Board			X		Strip			X		Strip			X					
Cover Pad			X		Strip			X		Strip			X					
					B.B. Pad			X		B.B. Pad			X					

Product Code

Style Case CLIP-PAD HOLDER

Sheet Size 11 x 8 1/2 Cap. 1/2

Die No. 5031<sup>A</sup>B Order No. 971780

Plate D-6-7

US GOVT. PRINTING

4-9

Customer

Metal
Total Vinyl
Quantity <u>500</u>
Date <u>3-30-92</u>
Type Corners
Radius <u>3/8"</u>
Completed

	Gauge	Thick
Tear Seal	<u>41-.016</u>	<u>1/16</u>
Bar Seal	<u>#30</u>	<u>3mm</u>
Bar Seal	<u>#20</u>	<u>1mm</u>

	No. of Feet
Tear Seal	
Bar Seal	
Bar Seal	

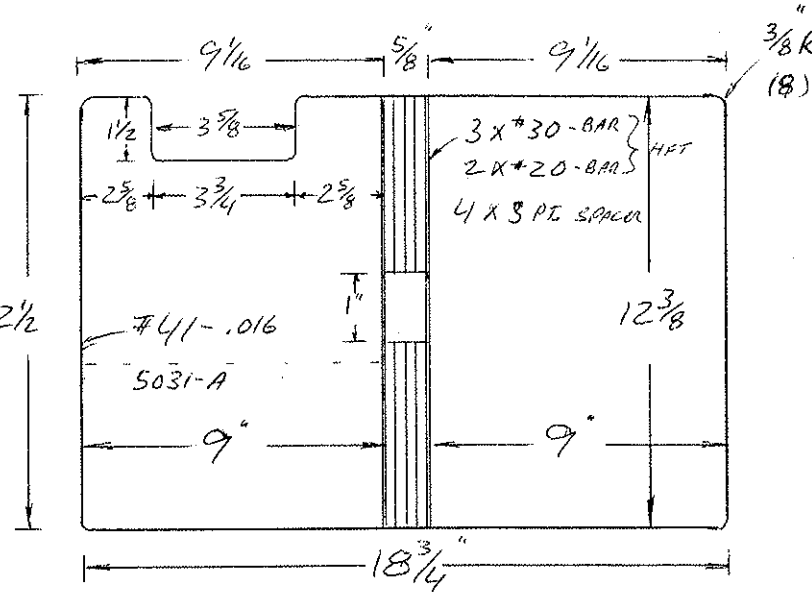

Dwg. B. Pae  
 CHECK. KPV

SEE 5031-B →

↓  
 1/2" → .037 3PT. PEN LOOP CUTTING DIE #5031-C  
 ↑  
 1/2"

Code		Ga.	# PCS	Size	Cutting Specs	Out	Code		Ga.	# Pcs.	Size	Cutting Specs	Out
Cover Mat.				<u>13 1/4 x 19 1/2</u>			Lining Mat.	<u>die cut SLIT</u>			<u>13 1/4 x 19 1/2</u>		
Cover Mat.				X			Lining Mat.				X		
Vert. Pckt.				X			Horz. Pckt.				<u>5 3/8 x 9 1/2</u>		<u>8 1</u>
Vert. Pckt.				X			Horz. Pckt.				X		
Pocket				X			Pocket				X		
Label Holder				X			Card holder				X		
Material				X			Material				X		
Material				X			Material				X		
Material				X			Material				X		
F.C. Board	<u>die</u>			<u>13 1/2 x 10</u>		<u>85 1</u>	B.C. Board				X		
B.C. Board	<u>Beer</u>			<u>12 5/16 x 8 15/16</u>		<u>85 1</u>	B.B. Board				X		
Center Board				X			Board				X		
Board				X			Strip				X		
Cover Pad				X			Strip				X		
							B.B. Pad				X		

DIE #	6416	METAL	CLIP	RADIUS	3/8"
ORDER #	989001	CUSTOMER	EINSON-FREEMAN	TEAR SEAL	NAT EDGE
SHEET SIZE		STYLE CASE	VINYL PAD HOLDER	BAR SEAL	253
CAP.		DUE DATE	2-6-98	COMPLETED	
LOCATION	G-11-9	QUANTITY	140	DATE	1-19-98

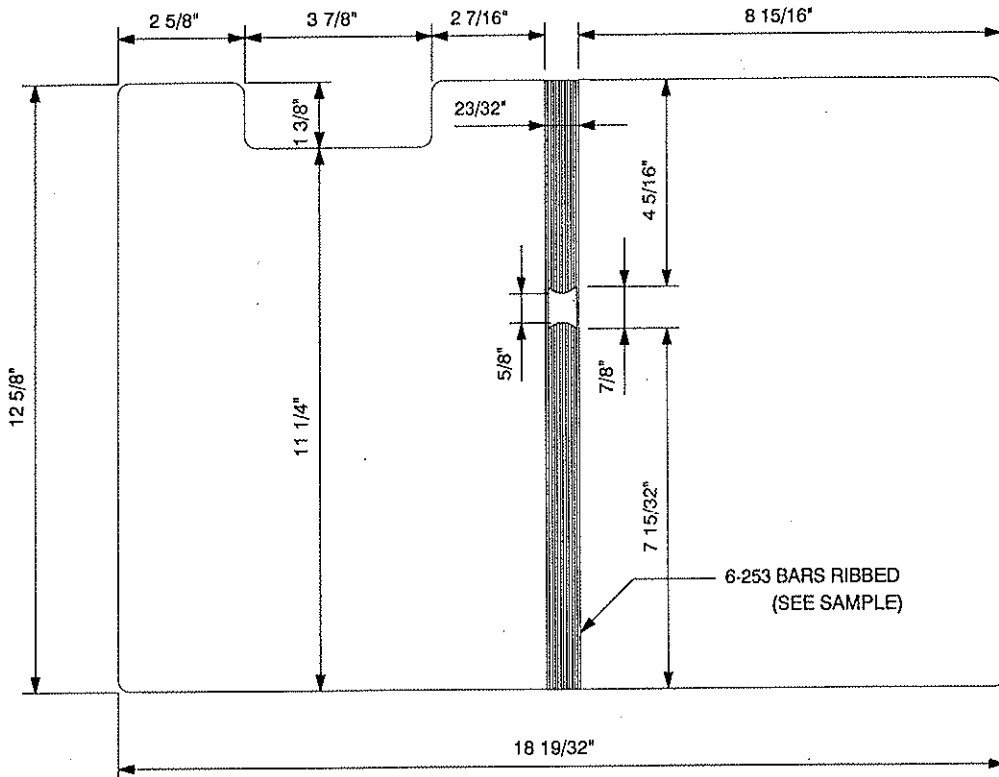

MATERIAL SPECS		GAUGE	PCS.	MATERIAL SPECS		GAUGE	PCS.
COVER MAT.	13 3/8 X 19 3/8		1	LINING MAT.			
COVER MAT.				LINING MAT.			
DIE CUT				HORZ. PKT.	5 3/8 X 9 1/2		1
COL				HORZ. PKT.	2 3/8 X 9 1/2		1
LABEL HOLDER				DIE CUT			
GUSSET				REINF.			

BOARD SPECS		GAUGE	PCS.	BOARD SPECS		GAUGE	PCS.
F.C. BOARD				F.C. BOARD			
B.B. BOARD				B.B. BOARD			
B.C. BOARD				B.C. BOARD			
FLAP BD.				DIE CUT			
BOARD				DIE CUT			

DIE #	6576-A	METAL	CLIP	RADIUS	1/4"-3/8"
ORDER #	169735	CUSTOMER	B J SERVICES	TEAR SEAL	.012
SHEET SIZE	11 X 8.5	STYLE CASE	VINYL PERMIT HOLDER	BAR SEAL	178
CAP.	1"	DUE DATE	10-23-98	COMPLETED	
LOCATION	A-18-7	QUANTITY	100	DATE	10-1-98

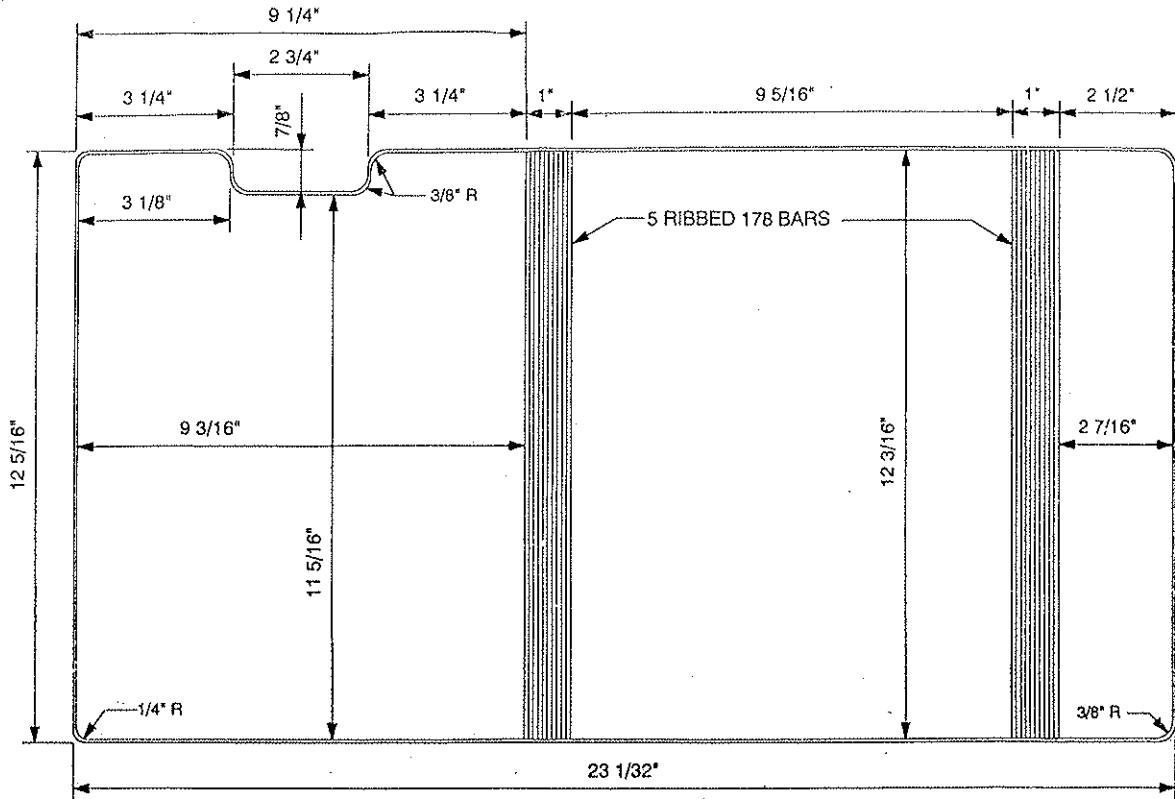

MATERIAL SPECS		GAUGE	PCS.	MATERIAL SPECS		GAUGE	PCS.	
COVER MAT.	13 1/8 X 23 3/4		1	LINING MAT.	13 1/8 X 23 3/4		1	
COVER MAT.				LINING MAT.				
DIE CUT				HORZ. PKT.	4 7/8 X 9 3/4		1	
COL				VERT. PKT.				
LABEL HOLDER				DIE CUT				
GUSSET				REINF.				
BOARD SPECS		5/16" R. CORNERS	GAUGE	PCS.	BOARD SPECS	5/16" R. CORNERS	GAUGE	PCS.
F.C. BOARD					F.C. BOARD			
B.B. BOARD					B.B. BOARD			
B.C. BOARD	12 1/8 X 9 1/4		120	1	B.C. BOARD			
FLAP BD.	12 1/8 X 2 11/32		120	1	DIE CUT			
BOARD					DIE CUT			