

Product Code

Style Case Carrying Case Binder

Sheet Size 11 x 9 Cap. 1/2 Die No. 3900 Order No. 956024 Plate

Customer California College of Podiatric Medicine

Metal
Total Vinyl
Quantity
Date
Type Corners <u>Rd + sq</u>
Radius <u>1/4</u>
Completed

Gauge	Thick
Tear Seal <u>16</u>	<u>1/32</u>
Bar Seal <u>3/16</u>	
Bar Seal	

No. of Feet
Tear Seal
Bar Seal
Bar Seal

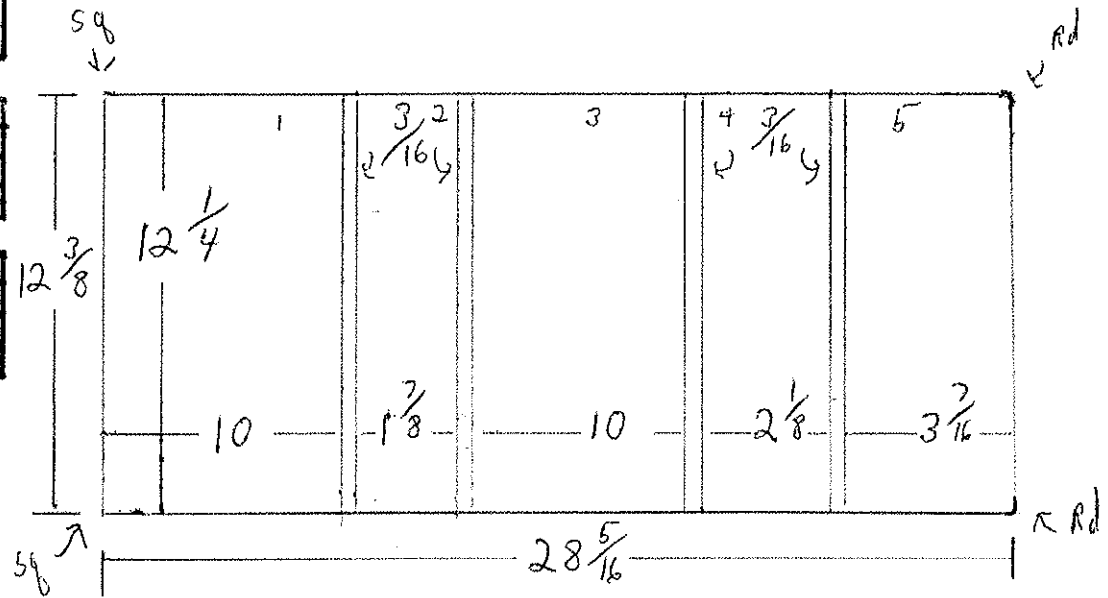

Code		Cutting Specs				Code		Cutting Specs			
		Ga.	PCS	Size	Out			Ga.	Pcs.	Size	Out
Cover Mat.	13 x 29		1			Lining Mat.	13 x 29		1		
Cover Mat	X					Lining Mat.	X				
Vert. Pckt.	X					Horz. Pckt.	X				
Vert. Pckt.	X					Horz. Pckt.	X				
Pocket	X					Pocket	X				
Label Holder	X					Card hlder	X				
Material	X					Material	X				
Material	X					Material	X				
Material	X					Material	X				
F.C. Board	1 12 3/16 x 9 15/16		1			B.C. Board	X				
B.C. Board	2 12 3/16 x 1 17/16		1			B.B. Board	X				
Center Board	3 12 3/16 x 9 15/16		1			Board	X				
Board	4 12 3/16 x 2 1/16		1			Strip	X				
Cover Pad	5 12 3/16 x 3 7/8		1			Strip	X				
						B.B. Pad	X				

Product Code

Style Case folder

Sheet Size 8 1/2 X 6

Cap. 1/2

Die No. 3963

Order No. 1000143

Plate

Customer

Chilton Corp.

Metal
Total Vinyl .030
Quantity 1
Date 2/12/88
Type Corners RD
Radius 1/4
Completed

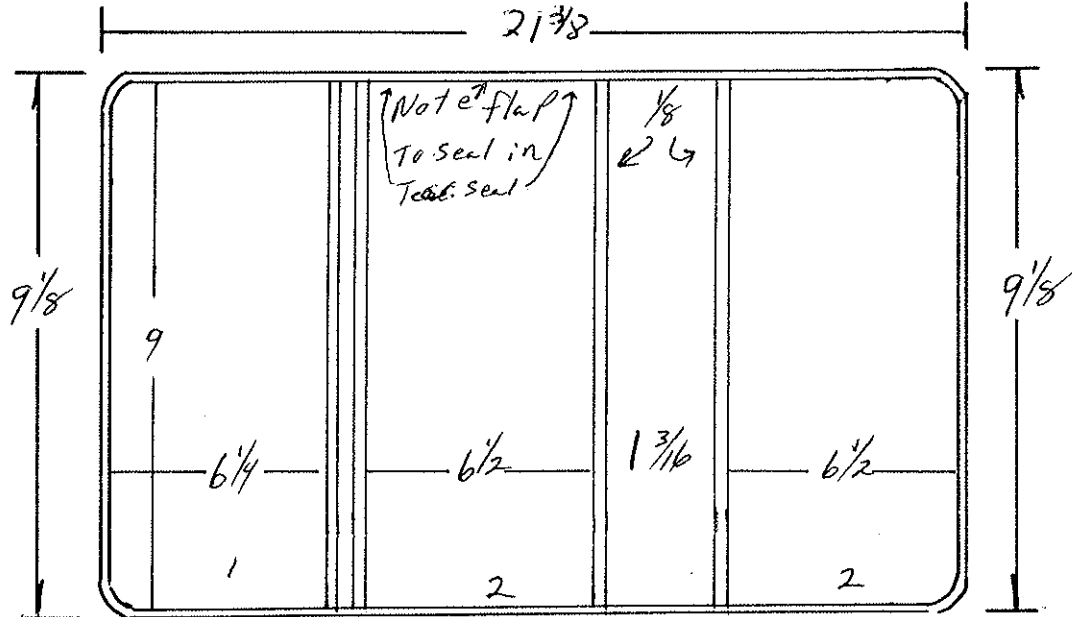

	Gauge	Thick
Tear Seal	.016	3/32
Bar Seal	178	3/16
Bar Seal	253	1/8

	No. of Feet
Tear Seal	
Bar Seal	
Bar Seal	

1/16 Back bone Bars
To be #178 grooved up

Code		Cutting Specs		Code		Cutting Specs			
		Ga.	PCS	Size	Out	Ga.	Pcs.	Size	Out
Cover Mat.	9 3/4 X 22		1			Lining Mat.	9 3/4 X 22		1
Cover Mat.	X					Lining Mat.	X		
Vert. Pckt.	4 9 3/4 X 6 5/16		1			Horz. Pckt.	2 6 7/16 X 6 7/8		1
Vert. Pckt.	X					Horz. Pckt.	3 3 15/16 X 6 7/8		1
Pocket	1 7 1/8 X 6 7/8		1			Pocket	X		
Label Holder	X					Card Holder	X		
Material	X					Material	X		
Material	X					Material	X		
Material	X					Material	X		
F.C. Board	1 8 29/32 X 6 5/32		1			B.C. Board	2 8 29/32 X 6 13/32		2
B.C. Board	X					B.B. Board	X		
Center Board	X					Board	X		
Board	X					Strip	X		
Cover Pad	X					Strip	X		
						B.B. Pad	X		

Product Code Special

Style Case Tri Fold

Sheet Size 8 3/8 X 5 1/2 Cap. 2/16 Die No. 4063 Order No. 959913 Plate

Customer Digital Matrix Systems, Inc.

Metal
Total Vinyl
Quantity
Date
Type Corners <u>R</u>
Radius <u>3/8</u>
Completed

	Gauge	Thick
Tear Seal	16	257
Bar Seal	2/16	178
Bar Seal	3/32	102

	No. of Feet
Tear Seal	
Bar Seal	
Bar Seal	

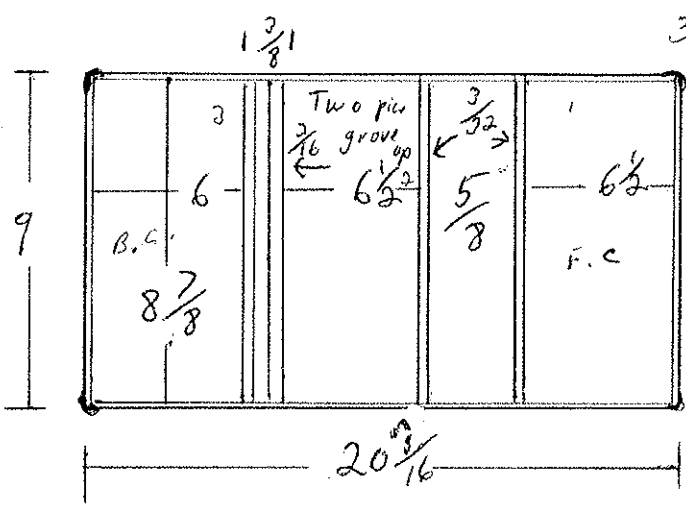

Round Corners

Code		Ga.	# PCS	Size	Out	Cutting Specs.	Code		Ga.	# Pcs.	Size	Out	Cutting Specs.
Cover Mat.	9 5/8 X 21 1/4						Lining Mat.	9 5/8 X 21 1/4					
Cover Mat	X						Lining Mat. Horiz. Pckt.	4 3/8 X 6 7/8	clear	1			
Vert. Pckt.	X						Horz. Pckt. Horiz.	3 1/4 X 6 7/8	clear	1			
Vert. Pckt.	X						Horz. Pckt. Diag.	6 7/8 X 7	clear	1			
Pocket	X						Pocket Vert.	9 5/8 X 6 1/2	white	1			
Label Holder	X						Card Holder	X					
Material	X						Material	X					
Material	X						Material	X					
Center	8 29/32 X 6 13/32	120	1			sq Corner	Material	X					
B.C. Board	8 25/32 X 5 29/32	120	1			Round Corner	B.C. Board	X					
F.C. Board	8 25/32 X 6 13/32	120	1			Round Corner	B.B. Board	8 25/32 X 6 13/32	1				
Board	8 13/16 X 5 15/16	100	1			Round Corner	Board	X					
Center Board	8 13/16 X 6 7/16	100	1			sq Corner	Strip	X					
FC Bd	8 13/16 X 6 7/16	100	1			Round Corner	Strip	X					
							B.B. Pad	X					

Product Code

Style Case 3 PANEL FOLDER

Sheet Size 11 X 9 Cap. 1 1/2 Die No. 4096

Order No. 960849.1 Plate

Customer MECK MFG.

NO

Metal
Total Vinyl
Quantity
Date
Type Corners <u>1/4 Round</u>
Radius <u>1/4</u>
Completed <u>11-15-88</u>

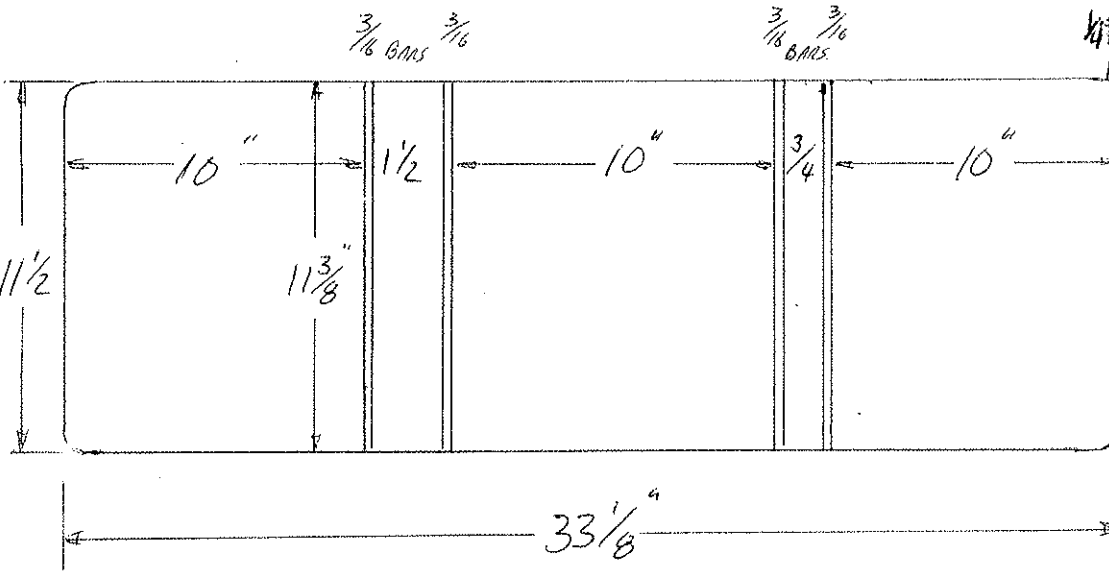

	Gauge	Thick
Tear Seal	<u>12</u>	
Bar Seal	<u>178</u>	<u>1/16</u>
Bar Seal		

	No. of Feet
Tear Seal	
Bar Seal	
Bar Seal	

*NOTE: DO NOT ROUND CORNER
CENTR BOARD.

Code	Ga.	# PCS	Size	Out	Cutting Specs	Code	Ga.	# Pcs.	Size	Out	Cutting Specs
Cover Mat.			<u>33 7/8 X 12 1/4</u>			Lining Mat.			<u>33 7/8 X 12 1/4</u>		
Cover Mat.			X			Lining Mat.			X		
Vert. Pckt.			X			Horz. Pckt. CLR.			<u>10 9/16 X 11 5/8</u>	<u>8</u>	<u>1</u>
Vert. Pckt.			X			Horz. Pckt. CLR.			<u>10 9/16 X 11 5/8</u>	<u>8</u>	<u>1</u>
Pocket			X			Pocket			X		
Label Holder			X			Card Holder			X		
Material			X			Material			X		
Material			X			Material			X		
Material			X			Material			X		
F.C. Board			<u>11 9/32 X 9 29/32</u>	<u>100</u>	<u>1</u>	B.C. Board			X		
B.C. Board			<u>11 9/32 X 9 29/32</u>	<u>100</u>	<u>1</u>	B.B. Board			<u>1 1/32 X 11 9/32</u>	<u>100</u>	<u>1</u>
Center Board	<u>502</u> <u>NOTE</u>		<u>11 9/32 X 9 29/32</u>	<u>100</u>	<u>1</u>	Board			<u>2 1/32 X 11 9/32</u>	<u>100</u>	<u>1</u>
Board			X			Strip			X		
Cover Pad			X			Strip			X		
						B.B. Pad			X		

Product Code

Style Case **3 PANEL FOLDER**

Per ORDER

Sheet Size **11 x 8 1/2** Cap. —

Die No. **4245**

Order No. **963084.1** Plate

Customer	JOHN HARLAND CO.	
Metal		
Total Vinyl		
Quantity		
Date	7-17-89	
Type Corners	RND.	
Radius	3/8"	
Completed		

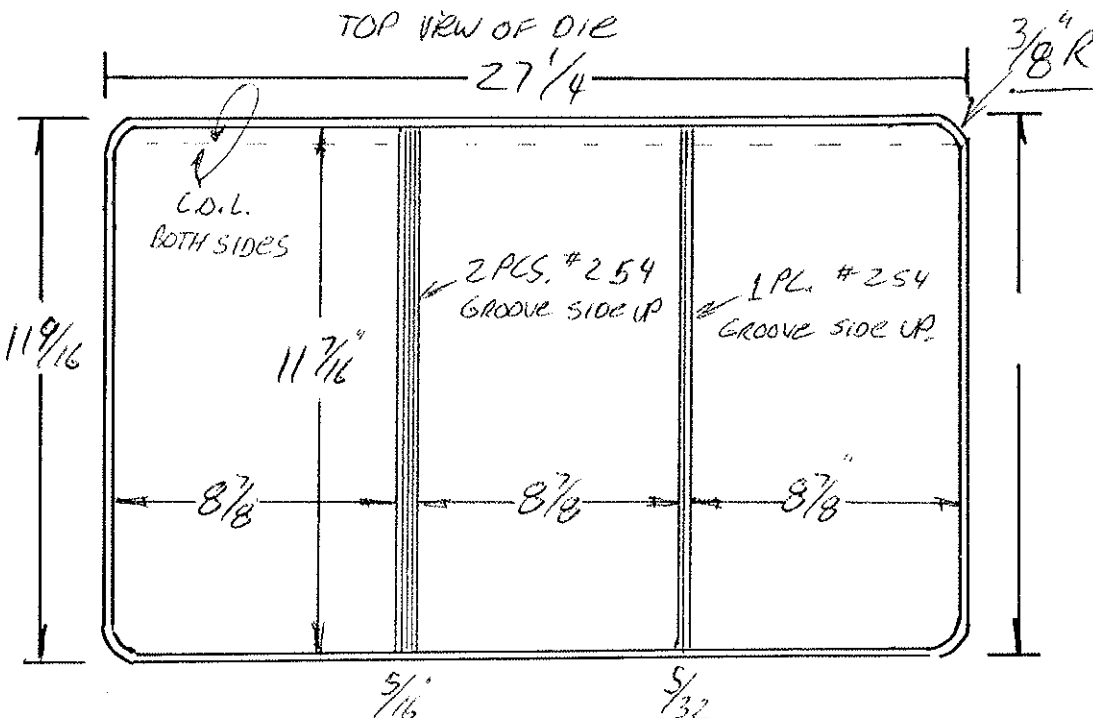

	Gauge	Thick
Seal	016"	3/32
Seal	254.	5/32"
Seal		

	No. of Feet
Seal	
Seal	
Seal	

Code		Cutting Specs		Code		Cutting Specs			
		Ga.	# PCS	Size	Out	Ga.	# PCS	Size	Out
Cover Mat.	12 1/4 x 28	15	1			Lining Mat.	12 1/4 x 28	15	1
Cover Mat	X					Lining Mat.	X		
Vert. Pckt.	X					Horz. Pckt. <small>FLAT CUT</small>	11 7/16 x 28	8	2
Vert. Pckt.	X					Horz. Pckt.	X		
Pocket	X					Pocket	X		
Label Holder	X					Card Holder	X		
Material	X					Material	X		
Material	X					Material	X		
Material	X					Material	X		
B.C. Board	R.C. 11 1/32 x 8 25/32	100	1			B.C. Board	X		
B.C. Board	SC. 11 1/32 x 8 25/32	100	1			B.B. Board	X		
Center Board	R.C. 11 1/32 x 8 25/32	100	1			Board	X		
Board	X					Strip	X		
Cover Pad	X					Strip	X		
						B.B. Pad	X		

Product Code

Style Case 3-PANEL FOLDER

ACTUAL Sheet Size 11 3/4 X 9 5/8" Cap. 1/2

Die No. 4278

Order No. 963524-5-6 Plate

Customer

MADISON ADVERTISING & FURNITURE

Metal
Total Vinyl
Quantity 1,000
Date 9-12-84
Type Corners
Radius 1/8
Completed

	Gauge	Thick
Tear Seal	.016	1/16
Bar Seal	4	
Bar Seal		

	No. of Feet
Tear Seal	
Bar Seal	
Bar Seal	

1/8" R.

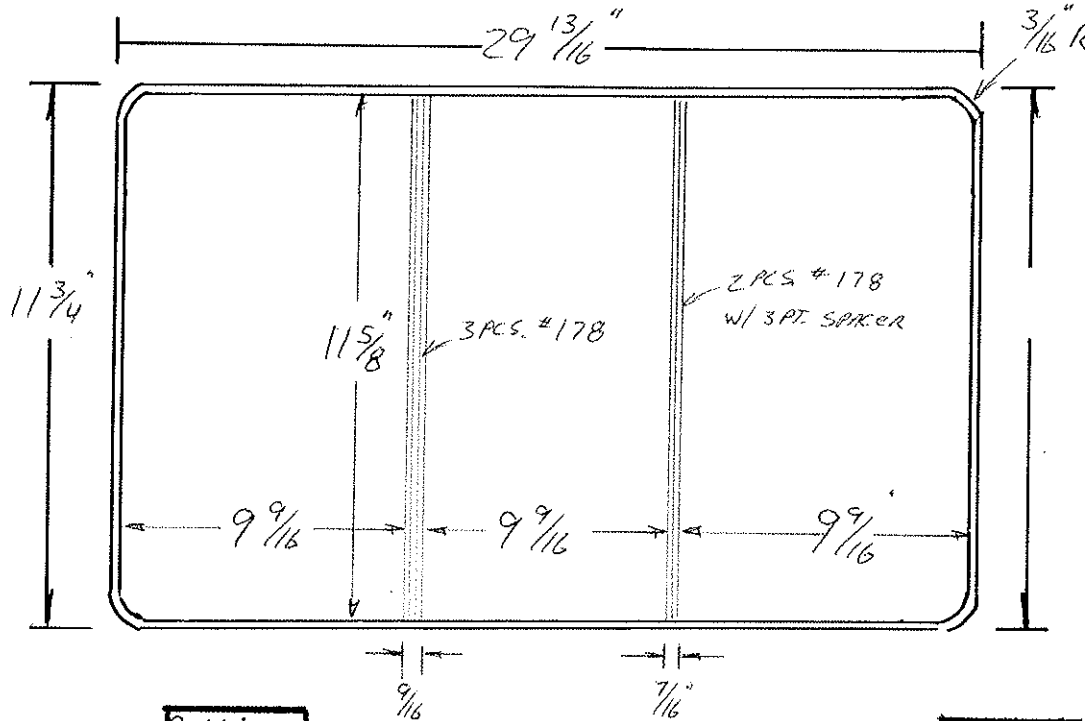

Code	Ga.	#	Cutting Specs		Code	Ga.	#	Cutting Specs	
			Size	Out				Size	Out
Cover Mat.		12 1/2 X 30 3/4	15	1	Lining Mat.		12 1/2 X 30 3/4	15	1
Cover Mat.		X			Lining Mat.		X		
Vert. Pckt.		X			Horz. Pckt.		X		
Vert. Pckt.		X			Horz. Pckt.		X		
Pocket		X			Pocket		X		
Label Holder		X			Card Holder		X		
Material		X			Material		X		
Material		X			Material		X		
Material		X			Material		X		
F.C. Board	1/4" R.C.	11 7/32 X 9 15/32	120	1	B.C. Board		X		
B.G. Board		11 7/32 X 9 15/32	120	1	B.B. Board		X		
Center Board	1/4" R.C.	11 7/32 X 9 15/32	120	1	Board	TIN Size	11 3/8 X 9 5/16		
Board		X			Strip		X		
Cover Pad		X			Strip		X		
					B.B. Pad		X		

Product Code

Style Case **3 PANEL FOLDER**

Overall Sheet Size **12 x 30³/₁₆** Cap. **1/2**

Die No. **4465-A** Order No. **965923**

Plate

Customer

McLEAN HILTON

Metal
Total Vinyl
Quantity
Date
Type Corners
Radius
Completed

	Gauge	Thick
Tear Seal	.014	
Bar Seal		
Bar Seal		

	No. of Feet
Tear Seal	
Bar Seal	
Bar Seal	

SIZE - B. PANEL
CHECK - **KPV**

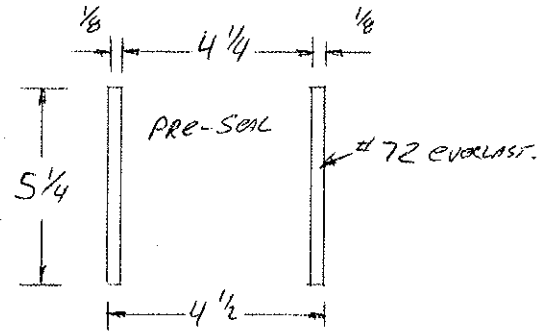
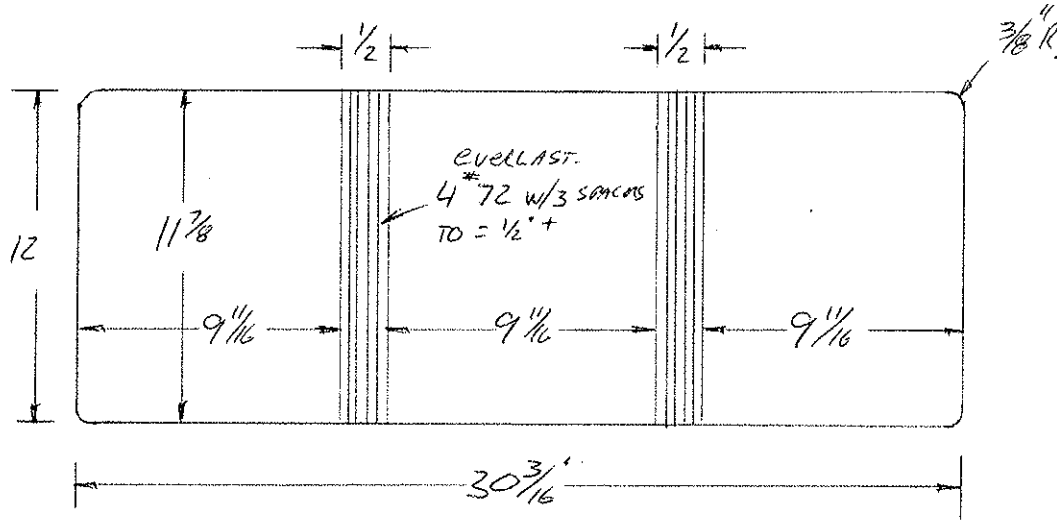

See cut list #4465-B

Code		Ga.		# PCS		Cutting Specs		Code		Ga.		# Pcs.		Cutting Specs	
						Size	Out					Size	Out		
Cover Mat.	12 ³ / ₄ x 31	15	1					Lining Mat.	12 ³ / ₄ x 31	15	1				
Cover Mat.	X							Lining Mat.	X						
Vert. Pckt.	12 ³ / ₄ x 5	8	1					Horz. Pckt.	7 ³ / ₈ x 10 ¹ / ₈	15	1				
Vert. Pckt.	X							Horz. Pckt.	5 ³ / ₈ x 10 ¹ / ₈	8	3				
Pocket	X							Pocket	X						
Label Holder	X							Card Holder	X						
Material	X							Material	X						
Material	X							Material	X						
Material	X							Material	X						
F.C. Board	OR CUT. 13 x 10 ³ / ₄	120	1					B.C. Board	X						
B.C. Board	11 ²⁵ / ₃₂ x 9 ¹⁹ / ₃₂	120	1					B.B. Board	X						
Center Board	11 ²⁵ / ₃₂ x 9 ¹⁹ / ₃₂	120	1					Board	X						
Board	X							Strip	X						
Cover Pad	X							Strip	X						
								B.B. Pad	X						

Product Code

Style Case TRI-FOLD VR3 W/6CAVCA

Sheet Size 11 x 9 Cap. 1/2 Die No. 4485 Order No. 59942 Plate

NSC

Customer

Metal
Total Vinyl
Quantity 750
Date 8-8-90
Type Corners
Radius 1/32
Completed

	Gauge	Thick
Tear Seal	.014	1/16"
Bar Seal	#253	1/8"
Bar Seal		

	No. of Feet
Tear Seal	
Bar Seal	
Bar Seal	

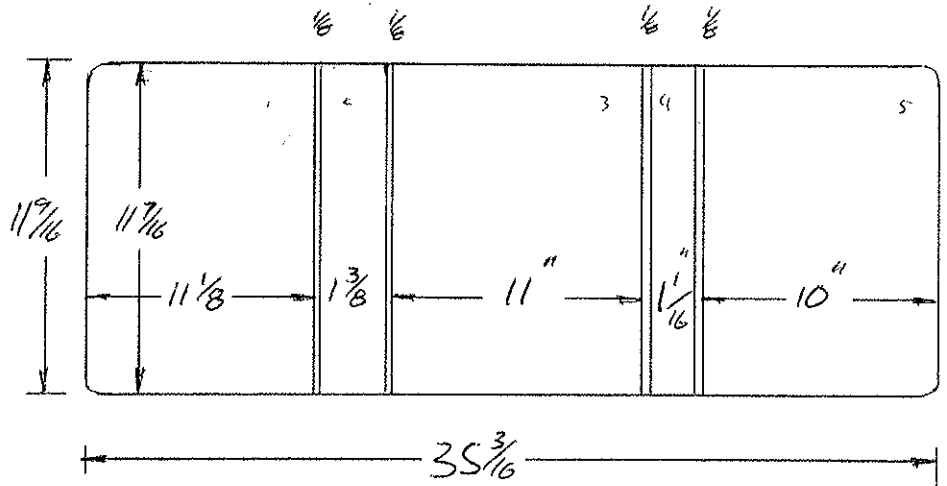

SIZE - B. Pkt
 CHORD VPV

Code		Ga. #		PCS		Cutting Specs		Code		Ga. #		PCS		Cutting Specs	
						Size	Out					Size	Out		
Cover Mat.		12 1/4	X	36"	15	1		Lining Mat.		12 1/4	X	36"	15	1	
Cover Mat.		X						Lining Mat.		X					
Vert. Pckt.		X						Horz. Pckt.		5 3/8	X	11 5/8			
Vert. Pckt.		X						Horz. Pckt.		X					
Pocket		X						Pocket		11 1/16	X	13 1/2	8	1	
Label Holder		X						Card Holder		2 5/8	X	4 1/8	8	1	
Material		X						Material		X					
Material		X						Material		X					
Material	CORNERS	X						Material		X					
F.C. Board	SQ.	11 1/32	X	11 1/32	100	1		B.B. Board		11 1/32	X	1 9/32	100	1	
B.C. Board	SQ.	11 1/32	X	10 29/32	100	1		B.B. Board		11 1/32	X	3 1/32	100	1	
Center Board	SQ.	11 1/32	X	9 29/32	100	1		Board		X					
Board		X						Strip		X					
Cover Pad		X						Strip		X					
								B.B. Pad		X					

Product Code

Style Case TRI-FOLD VRB W/6 CAN C

Sheet Size 11 X 9 Cap. 1"

Die No. 4507

Order No. 59942.1

Plate

NSC

Customer

Metal
Total Vinyl
Quantity <u>750</u>
Date <u>8-21-90</u>
Type Corners
Radius <u>1/32</u>
Completed

	Gauge	Thick
Tear Seal	.614	1/16
Bar Seal	#253	1/8
Bar Seal		

	No. of Feet
Tear Seal	<u>4</u>
Bar Seal	
Bar Seal	

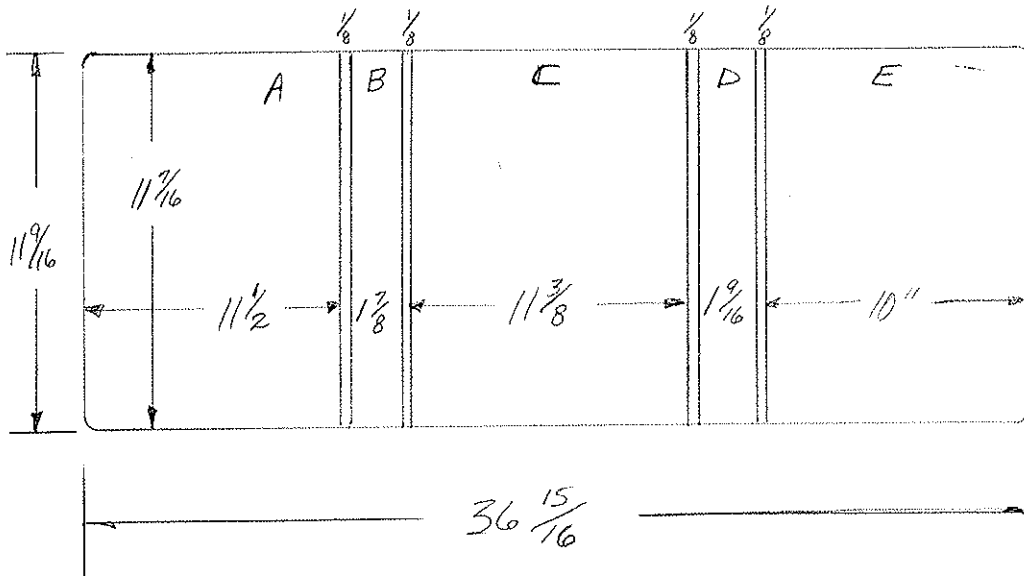

Dwg by: KP

Checked by: B.P.

Code		Cutting Specs				Code		Cutting Specs			
		Ga.	#	Size	Out			Ga.	#	Size	Out
Cover Mat.	$12 \frac{1}{4} \times 37 \frac{3}{4}$	15	1			Lining Mat.	$12 \frac{1}{4} \times 37 \frac{3}{4}$	15	1		
Cover Mat	X					Lining Mat.	X				
Vert. Pckt.	X					Horz. Pckt.	$5 \frac{3}{8} \times 12$	15	1		
Vert. Pckt.	X					Horz. Pckt.	X				
Pocket	X					Pocket	$11 \frac{1}{16} \times 14 \frac{3}{8}$	8	1		
Label Holder	X					Card Holder	$2 \frac{7}{8} \times 4 \frac{1}{8}$	8	1		
Material	X					Material	X				
Material	X					Material	X				
Material	<u>CORNERS</u> X					Material	X				
A F.C. Board	SQ $11 \frac{11}{32} \times 11 \frac{13}{32}$	100	1			B.B. Board	B $11 \frac{11}{32} \times 1 \frac{25}{32}$	100	1		
E B.C. Board	SQ $11 \frac{11}{32} \times 9 \frac{29}{32}$	100	1			B.B. Board	D $11 \frac{11}{32} \times 1 \frac{15}{32}$	100	1		
C Center Board	SQ $11 \frac{11}{32} \times 11 \frac{1}{4}$	100	1			Board	X				
Board	X					Strip	X				
Cover Pad	X					Strip	X				
						B.B. Pad	X				

Product Code

Style Case TRI-FOLD-VRB

Sheet Size 11 x 9 Cap. 1 1/2 A.D. Die No. 4630^B Order No. 967462 Plate K-1-E

Customer

COMMUNICATIONS, MKTY, & DIST. SVCS. INC.

Metal
Total Vinyl
Quantity 350
Date 1-9-91
Type Corners
Radius 3/8"
Completed

	Gauge	Thick
Tear Seal	.012	1/8"
Bar Seal	#253	1/8"
Bar Seal		

	No. of Feet
Tear Seal	
Bar Seal	
Bar Seal	

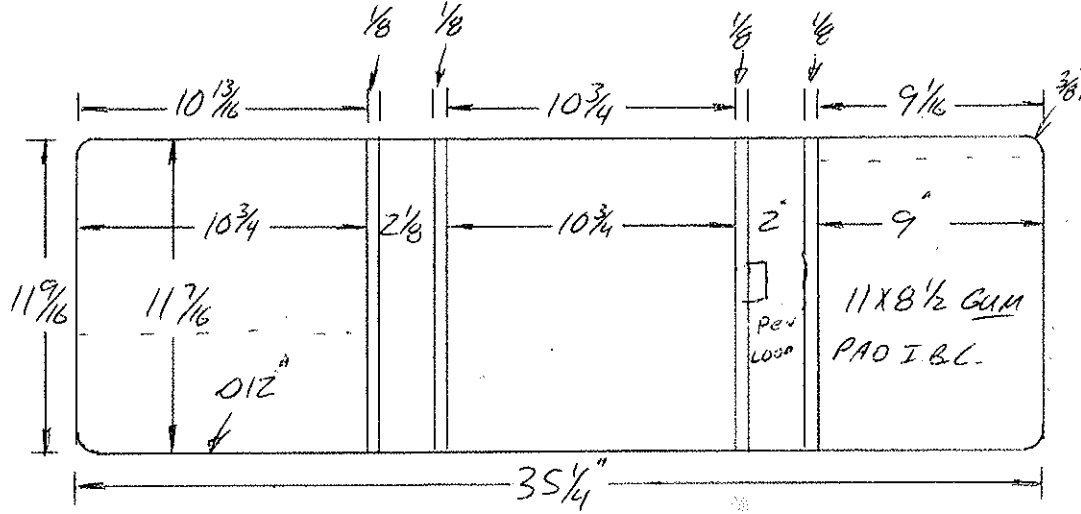

SIZE - BR.

CHECK - KPV

4630-B
PEN LOOP

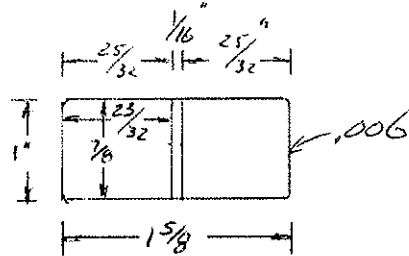

Code		Cutting Specs		Code		Cutting Specs		
Ga.	# PCS	Size	Out	Ga.	# PCS	Size	Out	
Cover Mat.		12 1/4 x 36 1/2	10	1	Lining Mat.	12 1/4 x 36 1/2	15	1
Cover Mat.		X			Lining Mat.	X		
Vert. Pckt.	I.F.C.	5 3/8 x 11 1/4	15	1	Horz. Pckt.	X		
Vert. Pckt.	I.B.C.	11 3/16 x 9 1/2	15	1	Horz. Pckt.	X		
Pocket		X			Pocket	X		
Label Holder		X			Card Holder	X		
Material		X			Material	Pen Loop 1 3/4 x 2 3/8	15	1
Material		X			Material	X		
Material		X			Material	X		
F.C. Board		11 1/32 x 10 2 1/2	120	1	B.B. Board	11 1/32 x 2	120	1
B.G. Board		11 1/32 x 8 2 1/2	120	1	B.B. Board	11 1/32 x 1 7/8	120	1
Center Board		11 1/32 x 10 2 1/2	120	1	Board	X		
Board		X			Strip	X		
Cover Pad		X			Strip	X		
					B.B. Pad	X		

Product Code

Style Case TRI-FOLD W/PVC TRAYS

ACTUAL Sheet Size 12 X 10 1/2 Cap. -

Die No. 470D

Order No. 968144

Plate

Customer

EASTERBY & ASSOCIATES, INC.

Metal
Total Vinyl
Quantity 1,000
Date 3-28-91
Type Corners
Radius
Completed

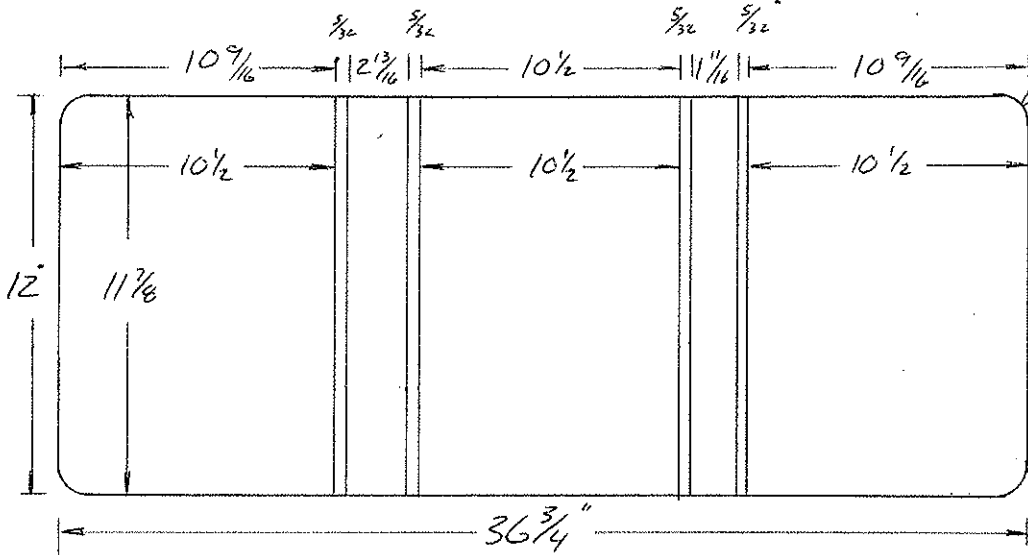

	Gauge	Thick
Tear Seal	.014	1/16
Bar Seal	#254	5/32"
Bar Seal		

	No. of Feet
Tear Seal	
Bar Seal	
Bar Seal	

SIZE - B. Pace

CHECK -

Code	Ga.	#	Cutting Specs		Code	Ga.	#	Cutting Specs											
			Size	Out				Size	Out										
Cover Mat.			12 3/4	X	37 3/4	15	1			Lining Mat.			12 3/4	X	37 3/4	15	1		
Cover Mat				X						Lining Mat.				X					
Vert. Pckt.				X						Horz. Pckt. OBC			5 3/8	X	11	15	1		
Vert. Pckt.				X						Horz. Pckt.				X					
Pocket				X						Pocket				X					
Label Holder			3 7/8	X	3 7/8		12			Card Hlder				X					
Material			15	X	20		1			Material				X					
Material				X						Material				X					
Material				X						Material				X					
F.C. Board			11 25/32	X	10 13/32	120	1			B.B. Board			11 25/32	X	2 23/32	120	1		
B.G. Board			11 25/32	X	10 13/32	120	1			B.B. Board			11 25/32	X	1 9/32	120	1		
Center Board			11 25/32	X	10 13/32	120	1			Board				X					
Board				X						Strip				X					
Cover Pad				X						Strip				X					
										B.B. Pad				X					

Product Code

Style Case TRI-FOLD.

Sheet Size 11 x 9

Cap. 15/16" 9/16" Die No. 4720

Order No. 968523

Plate C-13-6

Customer

THE CREATIVE FACTORY

Metal
Total Vinyl
Quantity 50
Date 4-19-91
Type Corners
Radius 3/8"
Completed

Gauge	Thick
Tear Seal .014	1/16
Bar Seal #178	-
Bar Seal	-

No. of Feet
Tear Seal
Bar Seal
Bar Seal

SIZE - B. Ppe
 CHELA KPV

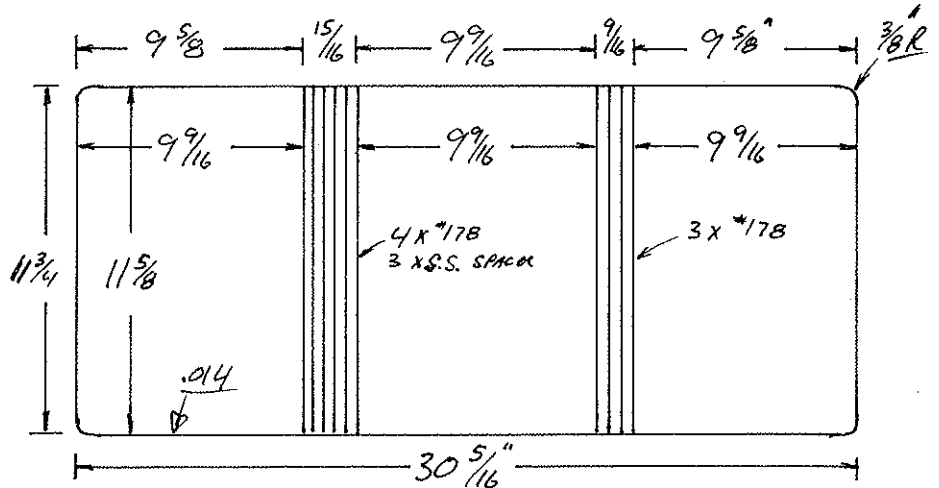

USE DIE # 4278-B FOR
 I.F.C. POCKET (U-2)

Code	Ga.	PCS	Cutting Specs		Code	Ga.	Pcs.	Cutting Specs	
			Size	Out				Size	Out
Cover Mat.		12 1/2 x 3 1/4	15	1	Lining Mat.		12 1/2 x 3 1/4	15	1
Cover Mat		X			Lining Mat.		X		
Vert. Pckt.		X			Horz. Pckt.		X		
Vert. Pckt.		12 1/2 x 9 3/8	8	1	Horz. Pckt.		11" x 9 5/16"	8	1
Pocket	012 4278-B	10 1/4 x 10 1/4	8	1	Pocket		X		
Label Holder		X			Card holder		X		
Material		X			Material #	PER COST 4630-B	1 3/4 x 2 5/8	8	1
Material		X			Material		X		
Material		X			Material		X		
F.C. Board	R.C.	11 17/32 x 9 15/32	100	1	B.C. Board		X		
B.C. Board	R.C.	11 17/32 x 9 15/32	100	1	B.B. Board		X		
Center Board	SQ.	11 17/32 x 9 15/32	100	1	Board		X		
Board		X			Strip		X		
Cover Pad		X			Strip		X		
					B.B. Pad		X		

Product Code

Style Case TRI-FOLD V.B.

Sheet Size 11 3/4 X 9

Cap. 3/4

Die No. 4852

Order No. 969787

Plate C-18-Z

Customer

THE CREATIVE FACTORY

8-16

Metal	
Total Vinyl	
Quantity	300
Date	8-9-91
Type Corners	
Radius	3/8
Completed	

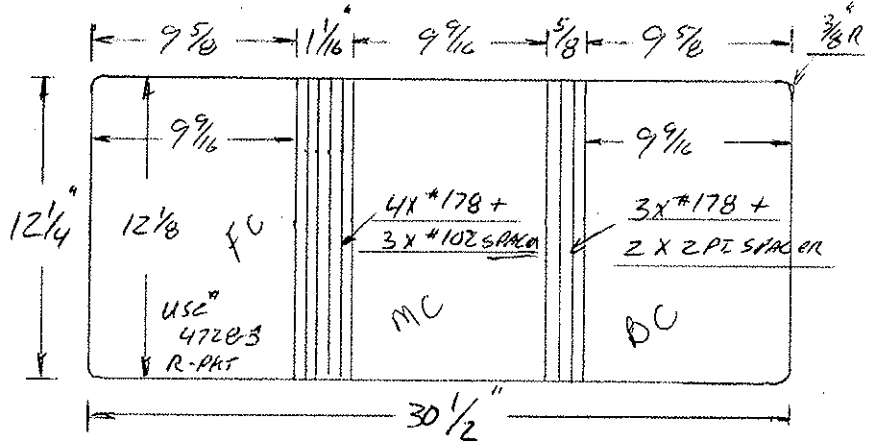

+ 1/8" BAR SEAL 11 1/4" Long
 + 3-.006 X 13 1/4" LONG

	Gauge	Thick
Tear Seal	.014	1/16
Bar Seal	#178+	see →
Bar Seal		

	No. of Feet
Tear Seal	
Bar Seal	
Bar Seal	

Dwg - B.P.
 Check. *(Signature)*

4852 REPLACES # 4720

Code		Cutting Specs				Code		Cutting Specs			
		Ga.	# PCS	Size	Out			Ga.	# Pcs.	Size	Out
Cover Mat.	13 1/4 X 31 1/2	exp.	1			Lining Mat.	13 1/4 X 31 1/2	exp.	1		
Cover Mat	X					Lining Mat.	X				
Vert. Pckt.	X					Horz. Pckt. FROSTY	11 5/8 X 10	8	1		
Vert. Pckt. FROSTY	13 1/4 X 9 5/8	8	1			Horz. Pckt.	X				
Pocket	X					Pocket	X				
Label Holder	X					Card Holder	X				
Material	X					Material FROSTY	1" X 2	8	1		
Material	X					Material	X				
Material	X					Material	X				
F.C. Board	12 1/32 X 9 15/32	100	1			B.C. Board	X				
B.C. Board	12 1/32 X 9 15/32	100	1			B.B. Board	X				
Center Board	12 1/32 X 9 15/32	100	1			Board	X				
Board	X					Strip	X				
Cover Pad	X					Strip	X				
						B.B. Pad	X				

Product Code

Style Case TRI-FOLD w/Gussets

Sheet Size 11 x 8 1/2 Cap. —

Die No. 4854

Order No. 969723

Plate K-4-L

Customer

MASTER READ OF MONTGOMERY

8-23

Metal	NONE
Total Vinyl	
Quantity	500
Date	8-13-91
Type Corners	
Radius	3/16
Completed	

	Gauge	Thick
Tear Seal	1014	1/16
Bar Seal	48-4	5/16
Bar Seal	178x6	3/16

	No. of Feet
Tear Seal	
Bar Seal	
Bar Seal	

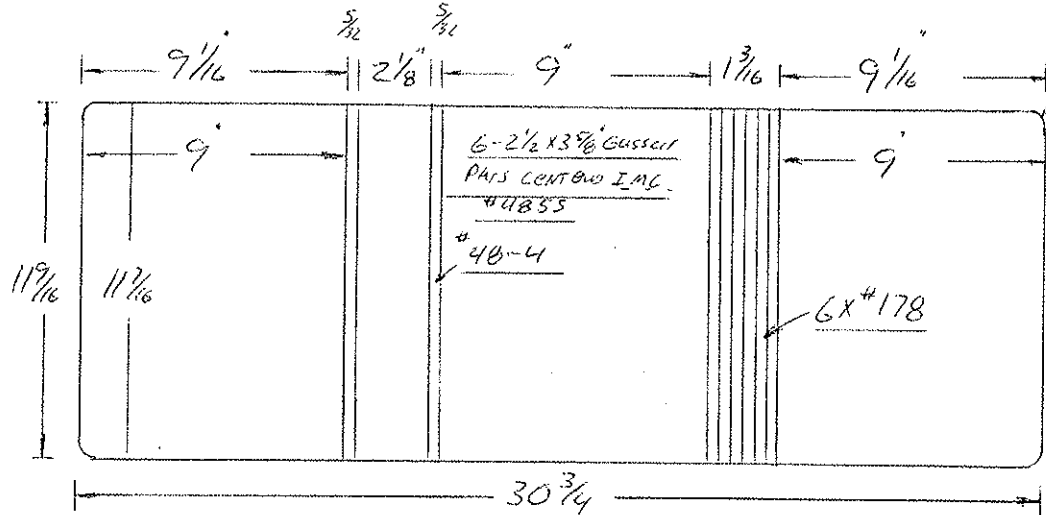

DWCJ - BA
 CHECA -

USE GUSSET # 4855 A-B

Code	Ga.	PCS	Cutting Specs		Code	Ga.	Pcs.	Cutting Specs		
			Size	Out				Size	Out	
Cover Mat.		14	12 1/4	31 3/4	Lining Mat.	14	1	12 1/4	31 3/4	
Cover Mat.				X	Lining Mat.				X	
Vert. Pckt.	8"	14	12 1/4	8 3/8	Horz. Pckt.				X	
Vert. Pckt.				X	Horz. Pckt.				X	
Pocket				X	Pocket				X	
Label Holder				X	Card Holder				X	
Material	col.	8	11 1/16	11 7/8	Material				X	
Material				X	Material				X	
Material				X	Material				X	
F.C. Board	R/C	120	11 1/32	8 29/32	B.C. Board				X	
B.C. Board	R/C	120	11 1/32	8 29/32	B.B. Board		120	1	11 1/32	2 1/32
Center Board	SO	120	11 1/32	8 29/32	Board				X	
Board				X	Strip				X	
Cover Pad				X	Strip				X	
					B.B. Pad				X	

Product Code

Style Case VINYL TRI-FOLD

Sheet Size 9 x 4

Cap. 1/4"

Die No. 4860

Order No. 969841

Plate C-18-4

Customer

STAMM ADVERTISING

8-29

Metal
Total Vinyl
Quantity 5,000
Date 8-16-91
Type Corners
Radius
Completed

	Gauge	Thick
Tear Seal	.008	1/16"
Bar Seal	#20+	500-
Bar Seal		

	No. of Feet
Tear Seal	
Bar Seal	
Bar Seal	

DWS. B.P.
 Check: KPT

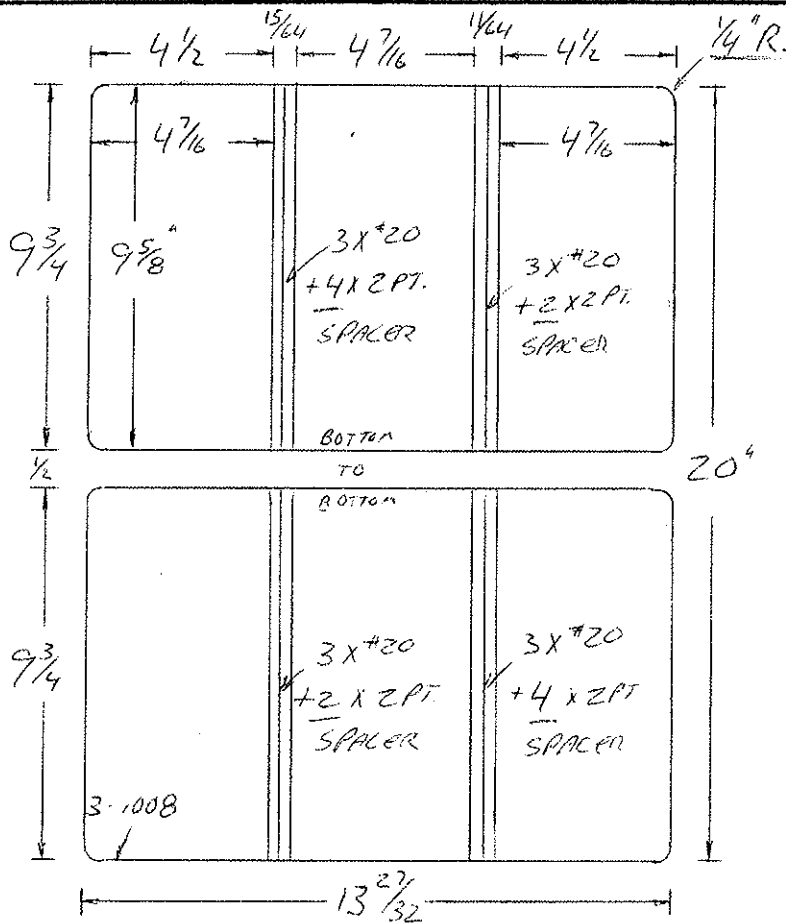

PER SAMPLE

Code	Ga.	#	Cutting Specs		Code	Ga.	#	Cutting Specs	
			Size	Out				Size	Out
Cover Mat.	2-out	20 3/4	X	14 7/8	Lining Mat.			X	
Cover Mat.			X		Lining Mat.			X	
Vert. Pckt.			X		Horz. Pckt.			X	
Vert. Pckt.			X		Horz. Pckt.	2-out	9 1/2	X	14 7/8
Pocket			X		Pocket			X	
Label Holder			X		Card Holder			X	
Material			X		Material			X	
Material			X		Material			X	
Material			X		Material			X	
F.C. Board			X		B.C. Board			X	
B.C. Board			X		B.B. Board			X	
Center Board			X		Board			X	
Board			X		Strip			X	
Cover Pad			X		Strip			X	
					B.B. Pad			X	

Product Code

Style Case TRI-FOLD

Size $11\frac{1}{2} \times 19\frac{7}{16}$ Cap. $\frac{3}{8}$

Die No. 5114 B

Order No. 972813

Plate D-9-1

WISTA CRAFT

7-30

Customer

Metal
Total Vinyl
Quantity 500
Date 7-8-42
Type Corners
Radius
Completed

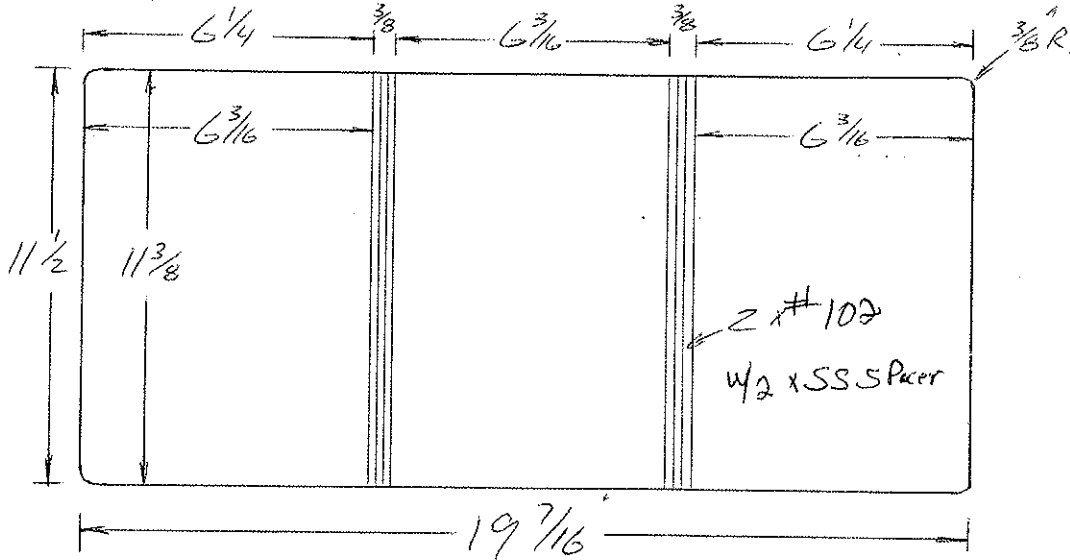

	Gauge	Thick
Tear Seal	.014	1/16
Bar Seal	#178	3/16 x 2
Bar Seal		

	No. of Feet
Tear Seal	
Bar Seal	
Bar Seal	

Dwg. B Pace

Check.

Code	Ga.	Pcs	Cutting Specs		Code	Ga.	Pcs.	Cutting Specs.	
			Size	Out				Size	Out
Cover Mat.			$12\frac{1}{4} \times 20\frac{1}{4}$		Lining Mat.			$12\frac{1}{4} \times 20\frac{1}{4}$	
Cover Mat.			X		Lining Mat.			X	
Vert. Pckt.			X		Horz. Pckt.	DIE CUT		DIE-BX	
Vert. Pckt.	F.M.C.		$12\frac{1}{4} \times 5\frac{7}{8}$	8 1	Horz. Pckt.	IFC EBC		$6\frac{1}{2} \times 7\frac{1}{2}$	8 2
Pocket			X		Pocket			X	
Label Holder			X		Card Holder			X	
Material			X		Material			X	
Material			X		Material			X	
Material			X		Material			X	
F.C. Board	R/C		$11\frac{5}{16} \times 6\frac{1}{8}$	100 1	B.C. Board			X	
B.C. Board	SQ.		$11\frac{5}{16} \times 6\frac{1}{8}$	100 1	B.B. Board			X	
Center Board	R/C		$11\frac{5}{16} \times 6\frac{1}{8}$	100 1	Board			X	
Board			X		Strip			X	
Cover Pad			X		Strip			X	
					B.B. Pad			X	

Product Code

Style Case

Vinyl Tri-fold

Sheet Size 11 x 8 1/2 Cap.

Die No. 5288

Order No. 974525

Plate

Customer

Colad

D16-9

Metal
Total Vinyl
Quantity 4
Date 2-22-93
Type Corners Sq
Radius 6 8
Completed

	Gauge	Thick
Tear Seal	.008	7/16
Bar Seal	HFT	#46
Bar Seal		

	No. of Feet
Tear Seal	
Bar Seal	
Bar Seal	

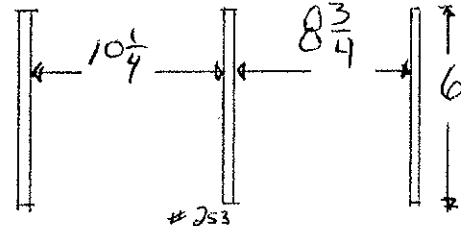

All Bars 1/8 HFT #46

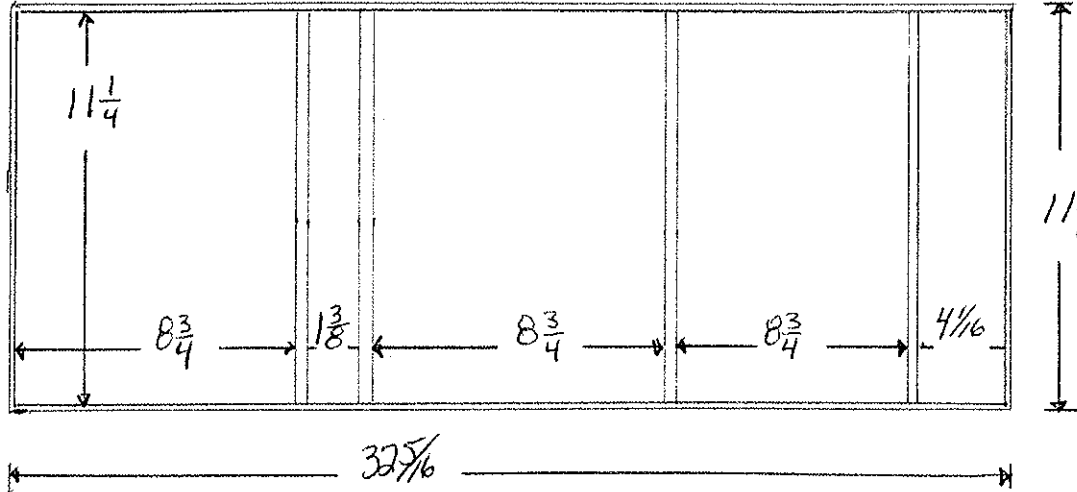

Code	Ga.	PCS	Cutting Specs		Code	Ga.	Pcs.	Cutting Specs	
			Size	Out				Size	Out
Cover Mat.		1	11 7/16	X 33 1/6	Lining Mat.		1	12 1/8	X 33 1/6
Cover Mat				X	Lining Mat.				X
Vert. Pckt.				X	Horz. Pckt.		1	3 1/8	X 28 9/16
Vert. Pckt.				X	Horz. Pckt.		1	3 3/8	X 33 1/6
Pocket				X	Pocket				X
Label Holder				X	Card Hlder				X
Material				X	Material				X
Material				X	Material				X
Material				X	Material				X
F.C. Board				X	B.C. Board				X
B.C. Board				X	B.B. Board				X
Center Board				X	Board				X
Board				X	Strip				X
Cover Pad				X	Strip				X
					B.B. Pad				X

Product Code

Style Case

Tri-fold

Sheet Size

11

X 8 1/2 + 1/2

Cap.

2 1/2

Die No. 5295

Order No.

974583.1

Plate

Customer

Foxmeyer Drug Co.

Metal
Total Vinyl
Quantity
Date 3-1-93
Type Corners RND
Radius 3/8
Completed

	Gauge	Thick
Tear Seal	.014	1/16
Bar Seal	484	5/32
Bar Seal		

	No. of Feet
Tear Seal	
Bar Seal	
Bar Seal	

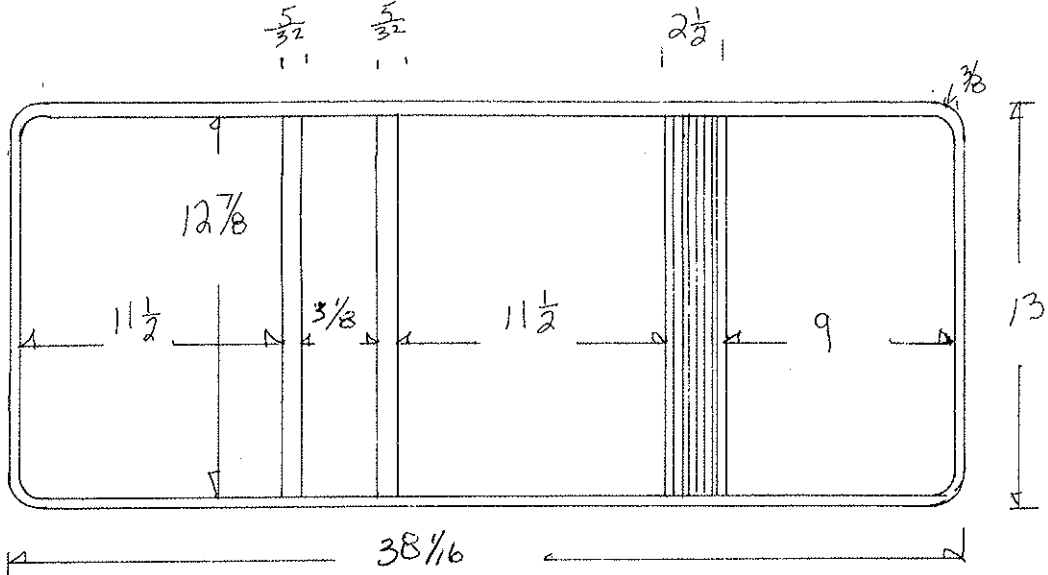

Code	Ga.	#	Cutting Specs		Code	Ga.	#	Cutting Specs	
			Size	Out				Size	Out
Cover Mat.			13 3/4 X	38 13/16	Lining Mt.			13 3/4 X	38 13/16
Cover Mat.			X		Lining Mat.			X	
Vert. Pckt.			X		Horz. Pckt.			X	
Vert. Rckt.			X		Horz. Pckt.			X	
Pocket			X		Pocket			13 3/16 X	38 13/16
Label Holder			X		Card Holder			X	
Material			X		Material			X	
Material			X		Material			X	
Material			X		Material			X	
F.C. Board	RND		12 25/32 X	11 13/32	B.C. Board			X	
B.C. Board	Sg		12 25/32 X	11 13/32	B.B. Board			X	
Center Board			12 25/32 X	3 1/32	Board			X	
Board	RND		12 25/32 X	8 29/32	Strip			X	
Cover Pad			X		Strip			X	
					B.B. Pad			X	

DIE # 5456		STYLE CASE DRING TRIFOLD			LOCATION K 6-8		
SHEET SIZE 11 3/4 X 8 1/2 + 1/2			CAP. 1 INCH		ORDER # 976701		
CUSTOMER GRAFACON				DUE DATE			
QUANTITY	2		RADIUS	3/8		TEAR SEAL	.014
DATE	11-16-93		COMPLETED			BAR SEAL	484

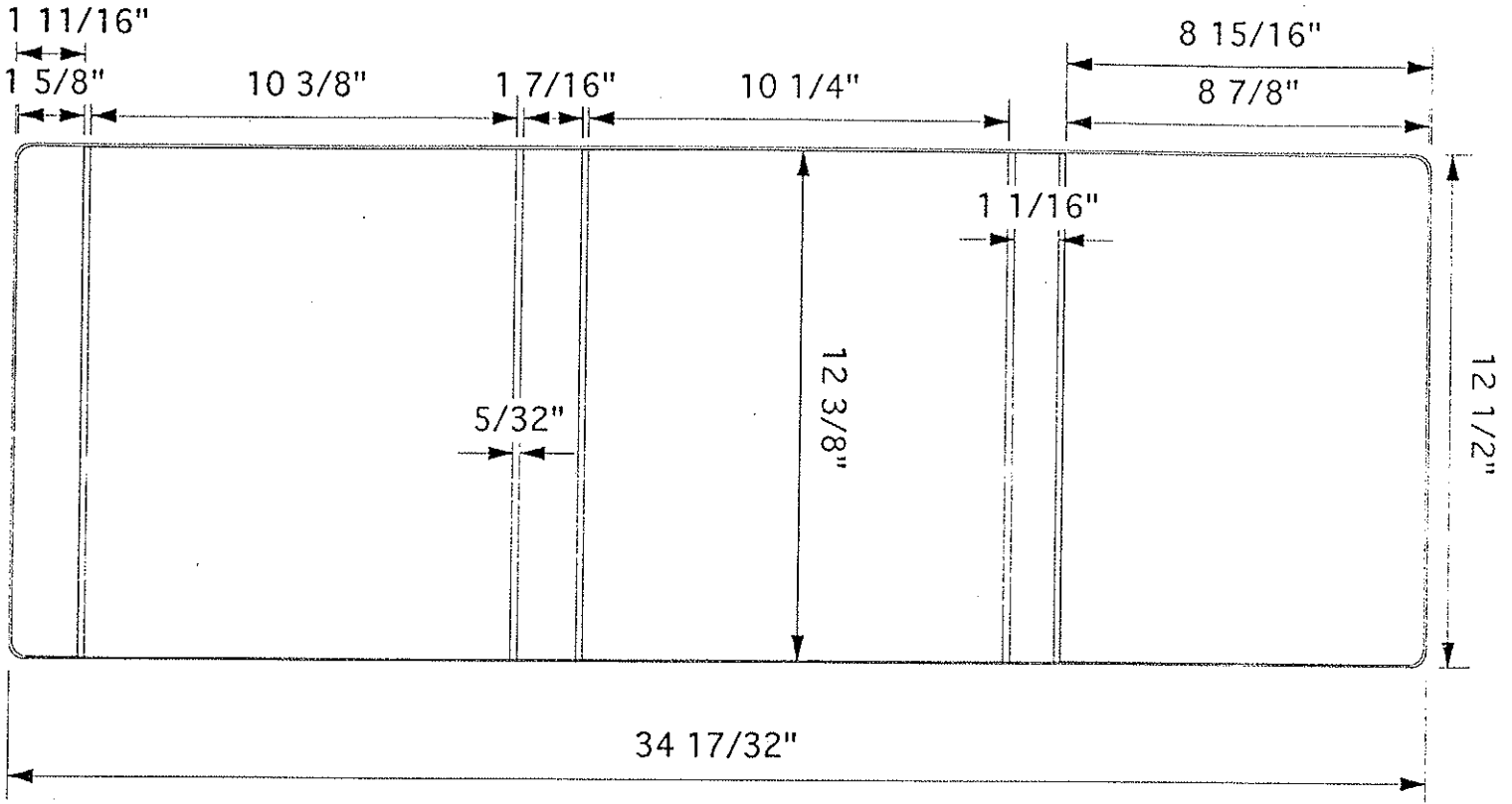

MATERIAL SPECS		GA		PCS		GA		PCS	
COVER MATL	13 1/4 x 35 5/16			LINING	13 1/4 x 35 5/16			1	
COVER MATL				LINING					
VERT PKT				HORZ PKT	5 3/8 x 10 11/16			1	
VERT PKT				HORZPKT	11 3/4 x 9 1/2			1	
CARD HOLDER				DIAGONAL PKT					
COL				LABEL HOLDER					
EX COL				GUSSETT					
				REINF					

BOARD SPECS									
F.C. BOARD	12 1/4	x	10 1/4	120	1	F.C. BOARD			
B.B. BOARD	12 1/4	x	1 5/16	120	1	B.B. BOARD			
B.C. BOARD	12 1/4	x	10 1/8	120	1	B.C. BOARD			
PAD HOLDER BRD	12 1/4	x	8 3/4	120	1				
BACK BONE	12 1/4	x	1	120	1				
FLAP	12 1/4	x	1 1/2	120	1				

DIE # 5464		STYLE CASE VINYL TRIFOLD		LOCATION	
SHEET SIZE 11 X 8 1/2		CAP.		ORDER # 976719	
CUSTOMER GRAPHITTI				DUE DATE	
QUANTITY	5000	RADIUS	3/8	TEAR SEAL	.014
DATE	11-18-93	COMPLETED		BAR SEAL	484

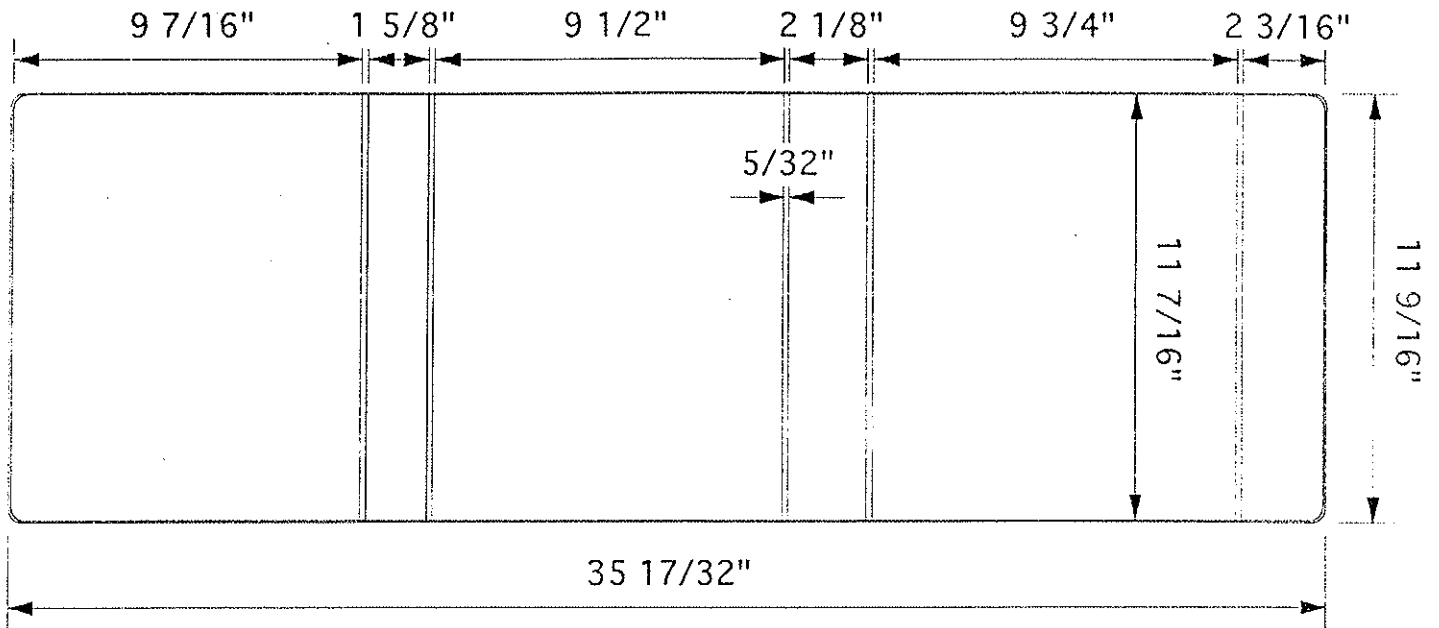

MATERIAL SPECS		GA		PCS		GA		PCS	
COVER MATL	13 5/16 X 36 9/32			1	LINING	13 5/16 X 36 9/32			1
COVER MATL					LINING				
VERT PKT					HORZ PKT				
VERT PKT					HORZPKT				
CARD HOLDER					DIAGONAL PKT				
COL					LABEL HOLDER				
EX COL					GUSSET I				
					REINF				

BOARD SPECS					
PADDED BOARD	13 3/8 X 20 7/8	100	1/2	F.C. BOARD	
B.B. BOARD	12 3/8 X 1 17/32	100	1	B.B. BOARD	
B.C. BOARD	12 3/8 X 9 3/8	100	1	B.C. BOARD	
PANEL BOARD	12 3/8 X 9 7/16	100	1		
FLAP	12 3/8 X 2 3/32	100	1		
	12 3/8 X 2 1/32	100	1		

DIE # 5542 A		STYLE CASE VINLY TRIFOLD		LOCATION E 7.9	
SHEET SIZE		CAP.		ORDER # 977222	
CUSTOMER RALPH WILSON PLASTICS CO				DUE DATE	
QUANTITY		RADIUS		TEAR SEAL	.012
DATE		COMPLETED		BAR SEAL	178

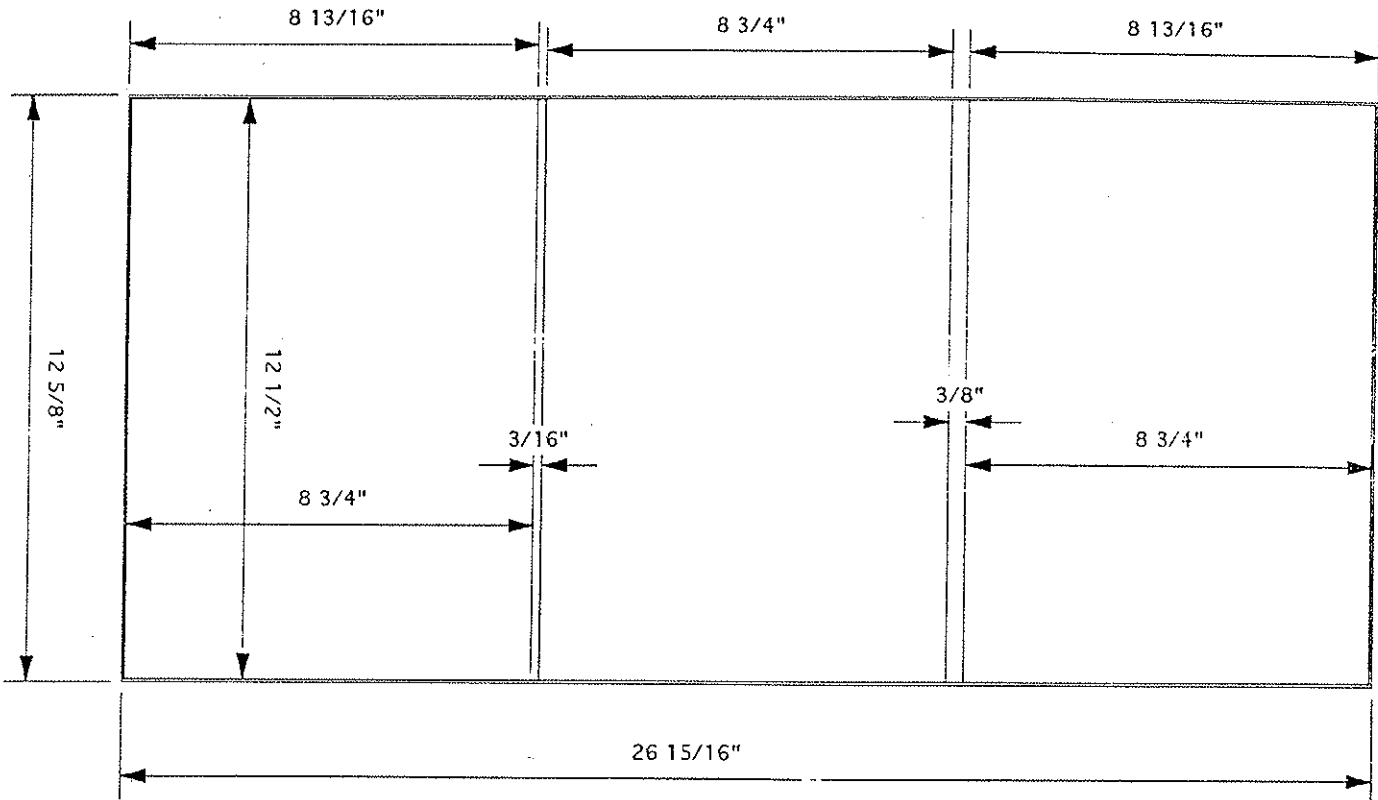

MATERIAL SPECS

GA PCS

GA PCS

COVER MATL	13 3/8 X 27 3/4	1	LINING	13 3/8 X 27 3/4	1
COVER MATL			LINING		
VERT PKT	1 5/8 X 6 7/8	78	HORZ PKT	5 3/8 X 9 3/16	1
VERT PKT	2 9/32 X 6 7/8	30	HORZPKT		
CARD HOLDER			DIAGONAL PKT		
COL			LABEL HOLDER		
EX COL			GUSSETT		
			REINF		

BOARD SPECS

F.C. BOARD	12 7/16 X 8 11/16	48	1	F.C. BOARD		
B.B. BOARD	12 7/16 X 8 11/16	48	1	B.B. BOARD		
B.C. BOARD	12 7/16 X 8 11/16	48	1	B.C. BOARD		
BU STRIP						

DIE # 5572		STYLE CASE ROUND RING TRIFOLD			LOCATION M 6-7	
SHEET SIZE 11 X 8 1/2 + 1/2		CAP. 1 INCH		ORDER # 978116		
CUSTOMER GRAFACON				DUE DATE		
QUANTITY	2	RADIUS	3/8	TEAR SEAL	.014	
DATE		COMPLETED		BAR SEAL	484	

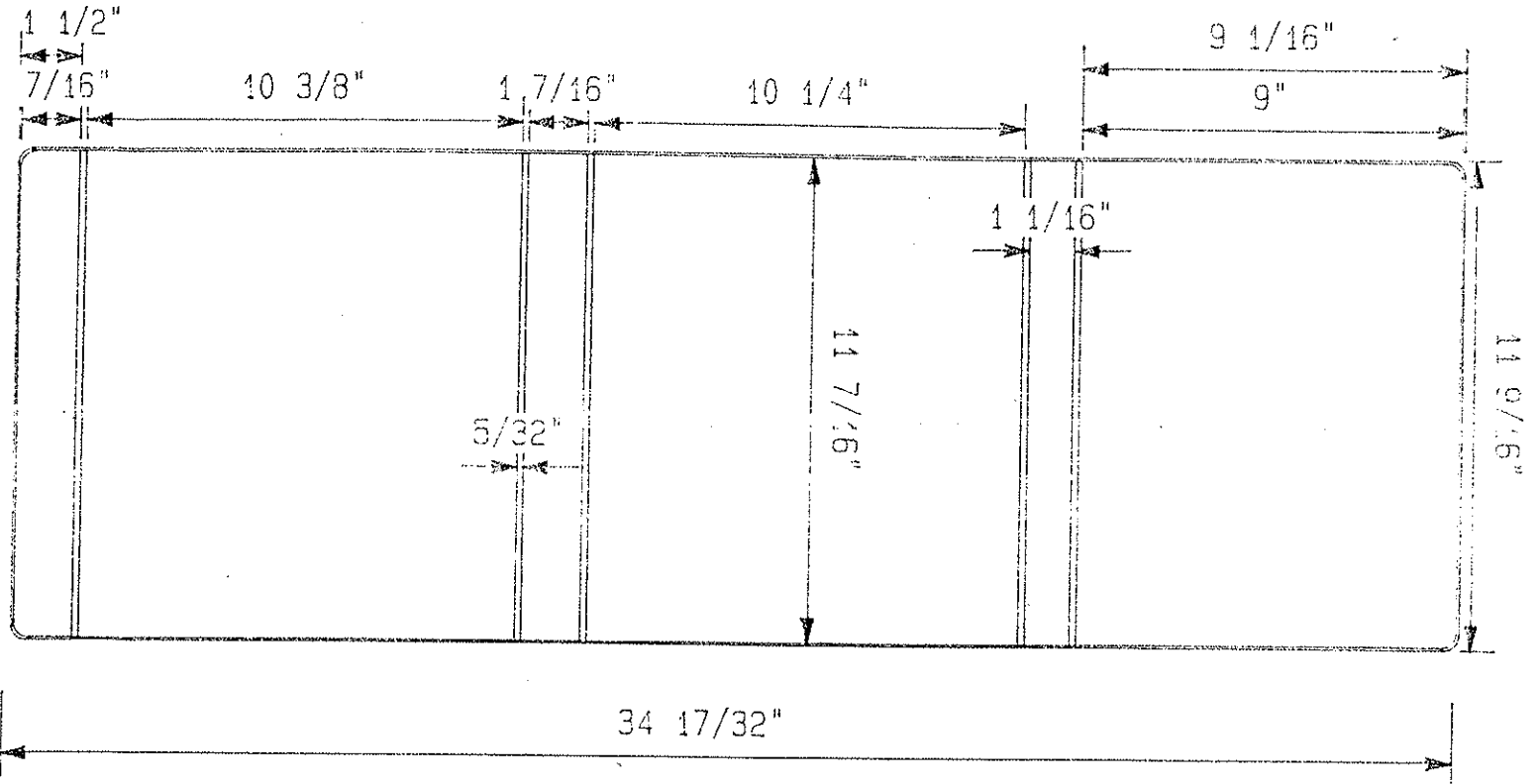

MATERIAL SPECS		GA		PCS		GA		PCS	
COVER MATL	12 1/4 x 35 5/16			LINING	12 1/4 x 35 5/16			1	
COVER MATL				LINING					
VERT PKT				HORZ PKT	5 3/8 X 10 11/16			1	
VERT PKT				HORZPKT	4 3/8 X 10 11/16			1	
CARD HOLDER				DIAGONAL PKT	5 3/8 X 9 3/8			1	
COL				LABEL HOLDER	4 3/8 X 9 3/8			1	
EX COL				GUSSETT					
				REINF					

BOARD SPECS									
F.C. BOARD	11 3/8 X 10 5/16	100	1	F.C. BOARD					
B.B. BOARD	11 3/8 x 1 11/32	100	1	B.B. BOARD					
B.C. BOARD	11 3/8 X 10 3/16	100	1	B.C. BOARD					
PAD HOLDER BIND	11 3/8 X 8 15/16	100	1						
BACK BONE	11 3/8 X 1 1/32	100	1						
FLAP	11 3/8 X 1 11/32	100	1						

DIE # 5682		CAP.		METAL	
STYLE CASE VINYL TRIFOLD				LOCATION E-15-7	
SHEET SIZE			ORDER # 979577		
CUSTOMER A S HOSPITALITY				DUE DATE 11-07-94	
QUANTITY	.100	RADIUS	1/4	TEAR SEAL	.014
DATE	10-10-94	COMPLETED		BAR SEAL	102

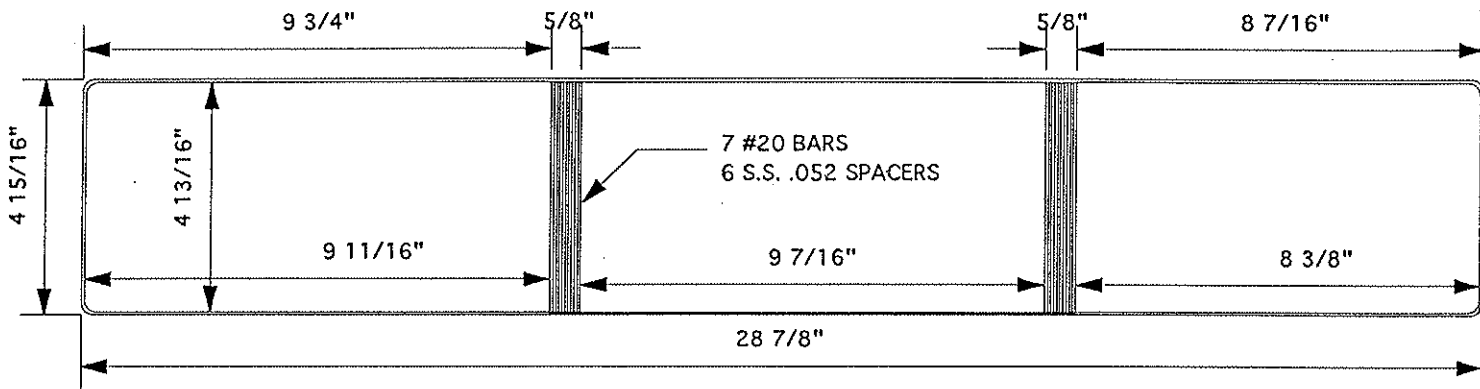

MATERIAL SPECS

		GA	PCS		GA	PCS
COVER MAT.	5 11/16 X 29 3/4		1	LINING MAT	5 11/16 X 29 3/4	1
COVER MAT.				LINING MAT		
VERT PKT	5 11/16 X 8 3/8		1	HORZ PKT		
CARD HOLDER				GUSSET		
COL				DIAGONAL PKT		
LABEL HOLDER				REINF		

BOARD SPECS

		GA	PCS		GA	PCS
F.C. BOARD	4 3/4 X 9 5/8	100	1	F.C. BOARD		
B.B. BOARD	4 3/4 X 9 3/8	100	1	B.B. BOARD		
B.C. BOARD	4 3/4 X 8 5/16	100	1	B.C. BOARD		
B.U. STRIP						

DIE #	5848	METAL	NONE	RADIUS	3/8
ORDER #	981570	CUSTOMER	JKLM MARKETING	TEAR SEAL	.014
SHEET SIZE	(OA)11 5/8 X9 1/4	STYLE CASE	VINYL TRIFOLD	BAR SEAL	102
CAP.		DUE DATE	6-7-95	COMPLETED	
LOCATION	F-7-4	QUANTITY	500	DATE	5-23-95

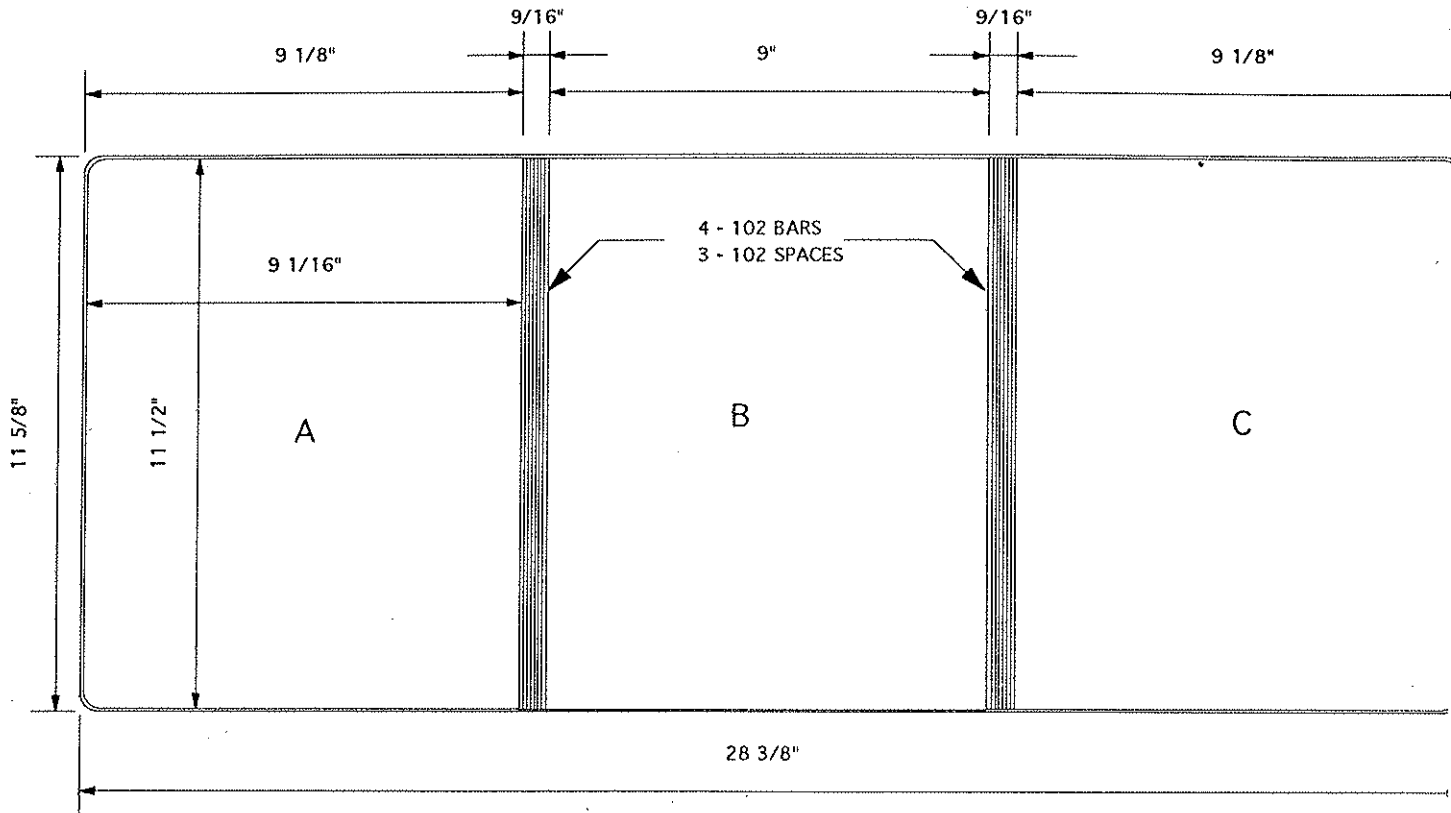

MATERIAL SPECS		GAUGE	PCS.	MATERIAL SPECS		GAUGE	P
COVER MAT.	12 5/16 X 29 1/8		1	LINING MAT.	12 5/16 X 29 1/8		
COVER MAT.				LINING MAT.			
DIE CUT				HORZ. PKT.	5 3/4 X 29 1/8		
COL				HORZ. PKT.	4 7/8 X 29 1/8		
LABEL HOLDER				DIE CUT			
GUSSET				REINF.			

BOARD SPECS		GAUGE	PCS.	BOARD SPECS		GAUGE	P
A BOARD	11 13/32 X 8 31/32	120	1	F.C. BOARD			
B BOARD	11 13/32 X 8 29/32	120	1	B.B. BOARD			
C BOARD	11 13/32 X 8 31/32	120	1	B.C. BOARD			
B.U. STRIP				DIE CUT			
DIE CUT				DIE CUT			

DIE #	5857	METAL		RADIUS	3/8
ORDER #	981727	CUSTOMER	LUCAS COUNTY HEALTH CENTER	TEAR SEAL	.014
SHEET SIZE		STYLE CASE	VINYL BINDER W/FLAPS	BAR SEAL	253
CAP.		DUE DATE	7-14-95	COMPLETED	
LOCATION	F-7-8	QUANTITY	50	DATE	6-13-95

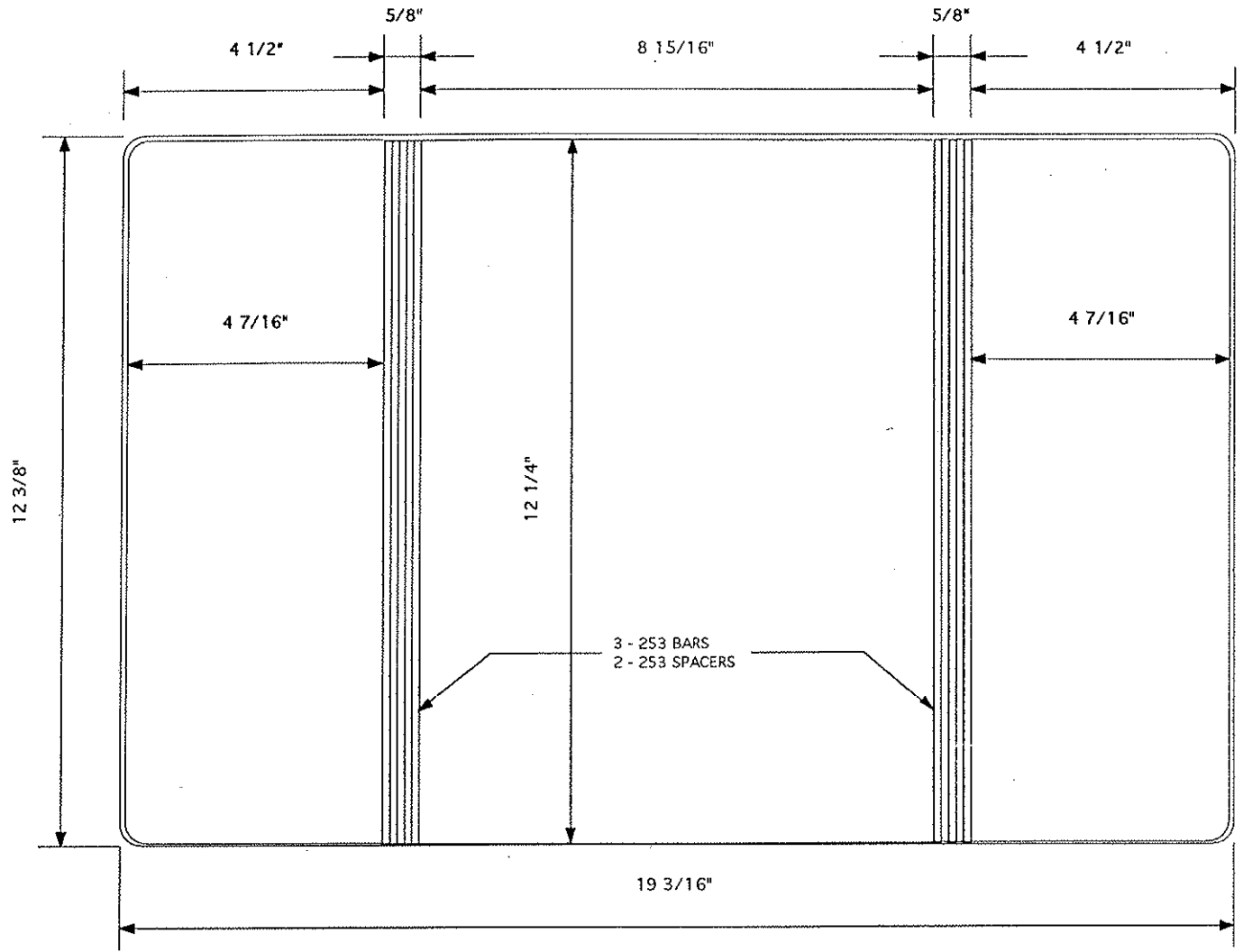

MATERIAL SPECS		GAUGE		PC.		MATERIAL SPECS		GAUGE		PC.	
COVER MAT.	13 1/8 X 20 3/16			1		LINING MAT.	13 1/8 X 20 3/16			1	
COVER MAT.						LINING MAT.					
DIE CUT						HORZ. PKT.	12 1/8 X 9 1/4			1	
COL						VERT. PKT.	13 1/8 X 4 7/8			2	
LABEL HOLDER						DIE CUT					
GUSSET						REINF.					

BOARD SPECS		GAUGE		PC.		BOARD SPECS		GAUGE		PC.	
CENTER BD.	12 5/32 X 8 27/32	120	1	1		F.C. BOARD					
FLAP BDS.	12 5/32 X 4 11/32 (PADDED)	120	2	2		B.B. BOARD					
B.C. BOARD						B.C. BOARD					
B.U. STRIP						DIE CUT					
DIE CUT						DIE CUT					

DIE #	5998-A	METAL		RADIUS	1/4
ORDER #	983731	CUSTOMER	ADEMCO	TEAR SEAL	.014
SHEET SIZE	11 X 9	STYLE CASE	VINYL TRI FOLD FOLDER	BAR SEAL	253
CAP.		DUE DATE	2-19-96	COMPLETED	
LOCATION	F-3-3	QUANTITY	500	DATE	2-2-96

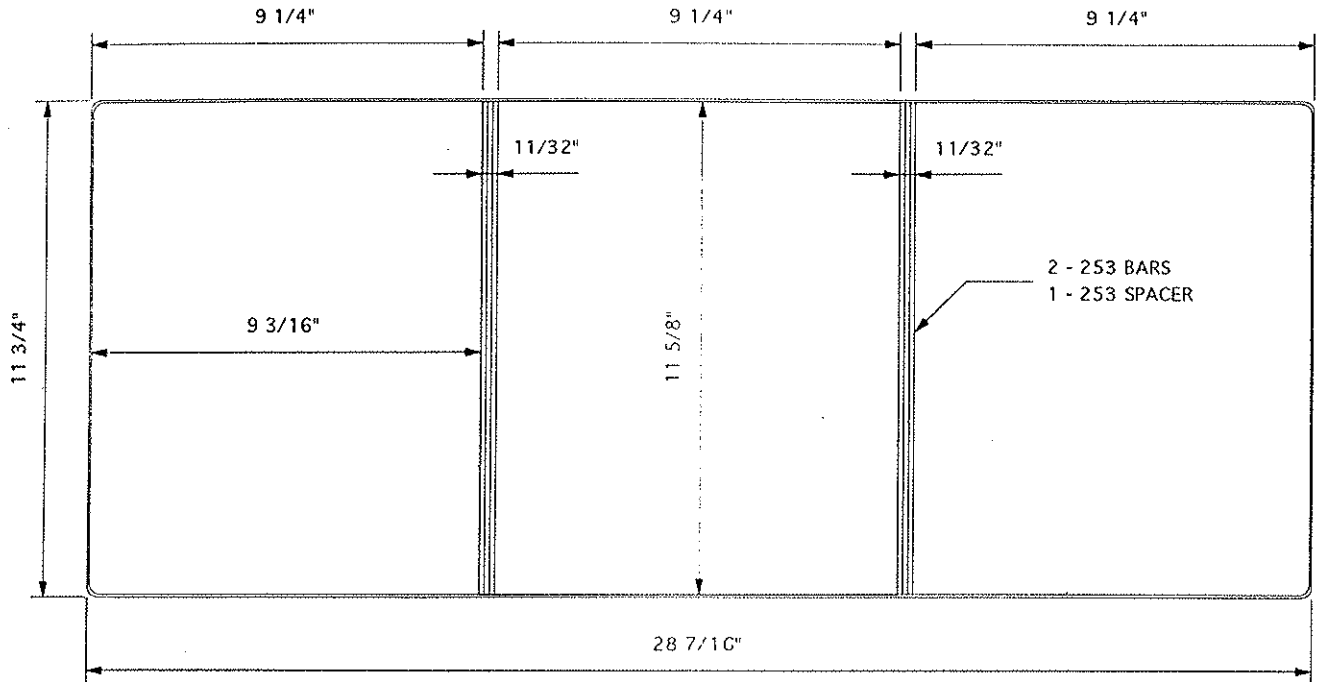

MATERIAL SPECS		GAUGE		PCS.		MATERIAL SPECS		GAUGE		PCS.	
COVER MAT.	12 1/2 X 29 1/4			1		LINING MAT.	12 1/2 X 29 1/4			1	
COVER MAT.						LINING MAT.					
DIE CUT						HORZ. PKT.	5 1/2 X 30	DIE 5998-B	CLEAR	1	
COL						HORZ. PKT.	5 3/4 X 30	DIE 5998-C		1	
LABEL HOLDER						DIE CUT					
GUSSET						REINF.					

BOARD SPECS		GAUGE		PCS.		BOARD SPECS		GAUGE		PCS.	
F.C. BOARD	11 9/16 X 9 1/8	100		1		F.C. BOARD					
B.B. BOARD	11 9/16 X 9 3/16	100		1		B.B. BOARD					
B.C. BOARD	11 9/16 X 9 1/8	100		1		B.C. BOARD					
B.U. STRIP						DIE CUT					
DIE CUT						DIE CUT					

DIE #	6238-A	METAL	NONE	RADIUS	1/4"
ORDER #	987033	CUSTOMER	KWIK KOPY CORP	TEAR SEAL	.014
SHEET SIZE		STYLE CASE	3 PANEL VINYL FOLDER	BAR SEAL	253
CAP.		DUE DATE	5-2-97	COMPLETED	
LOCATION	H-5-1	QUANTITY	300	DATE	4-22-97

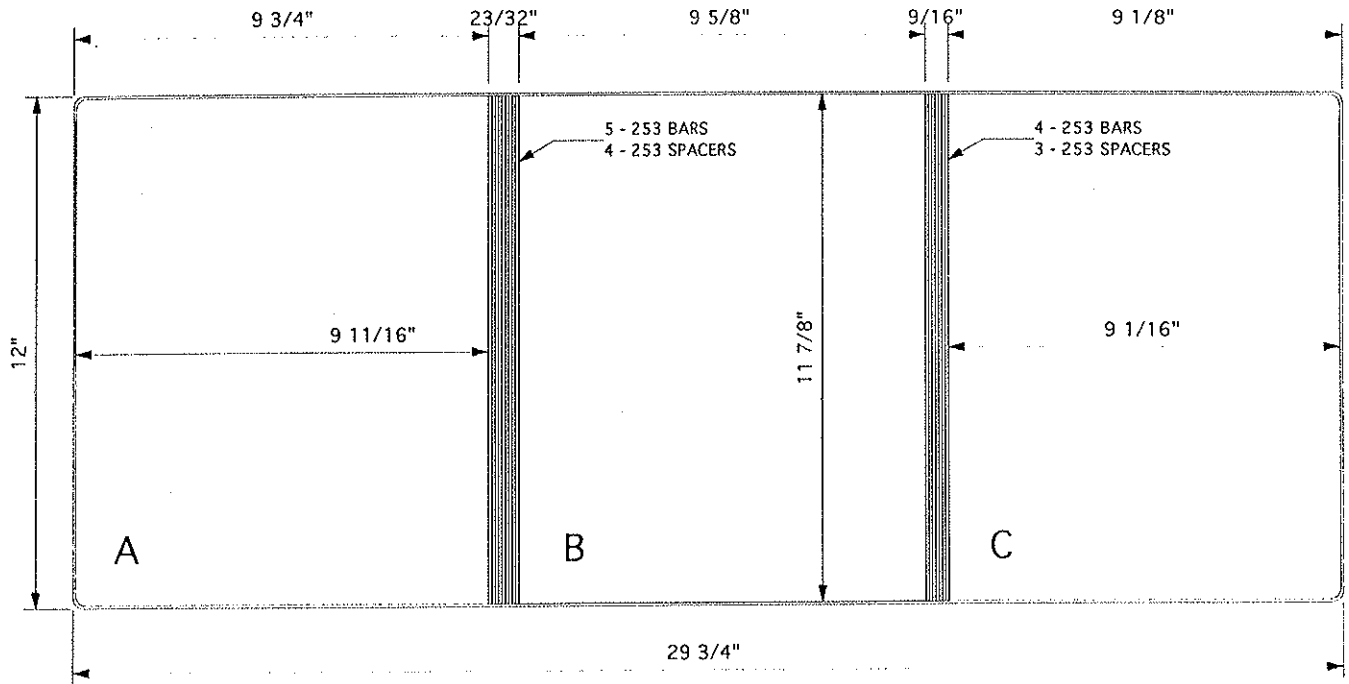

MATERIAL SPECS		GAUGE		MATERIAL SPECS		GAUGE	
COVER MAT.	12 3/4 X 30 1/2		1	LINING MAT.	12 3/4 X 30 1/2		
COVER MAT.				OUTSIDE PKT	5 1/4 X 9 5/8		
DIE CUT				HORZ. PKT.	5 1/4 X 9 5/8		
COL				HORZ. PKT.	5 1/4 X 9 3/16	LT-6238-B	
PEN LOOP	2 X 1		1	VERT. PKT.	12 3/4 X 4 5/8		
GUSSET				REINF.			

BOARD SPECS		GAUGE		BOARD SPECS		GAUGE	
A BOARD	11 25/32 X 9 17/32	PADDED	100	1	F.C. BOARD		
B BOARD	11 13/16 X 9 9/16		100	1	B.B. BOARD		
C BOARD	11 13/16 X 9		100	1	B.C. BOARD		
FLAP BD.					DIE CUT		
BOARD					DIE CUT		

DIE #	6384-A	METAL	LOC	RADIUS	3/8"
ORDER #	988690	CUSTOMER	PROMUS	TEAR SEAL	.012
SHEET SIZE	11 X 9	STYLE CASE	VRB TRIFOLD	BAR SEAL	253
CAP.	1 1/2"	DUE DATE	12-17-97	COMPLETED	
LOCATION	G-13-2	QUANTITY	1	DATE	12-4-97

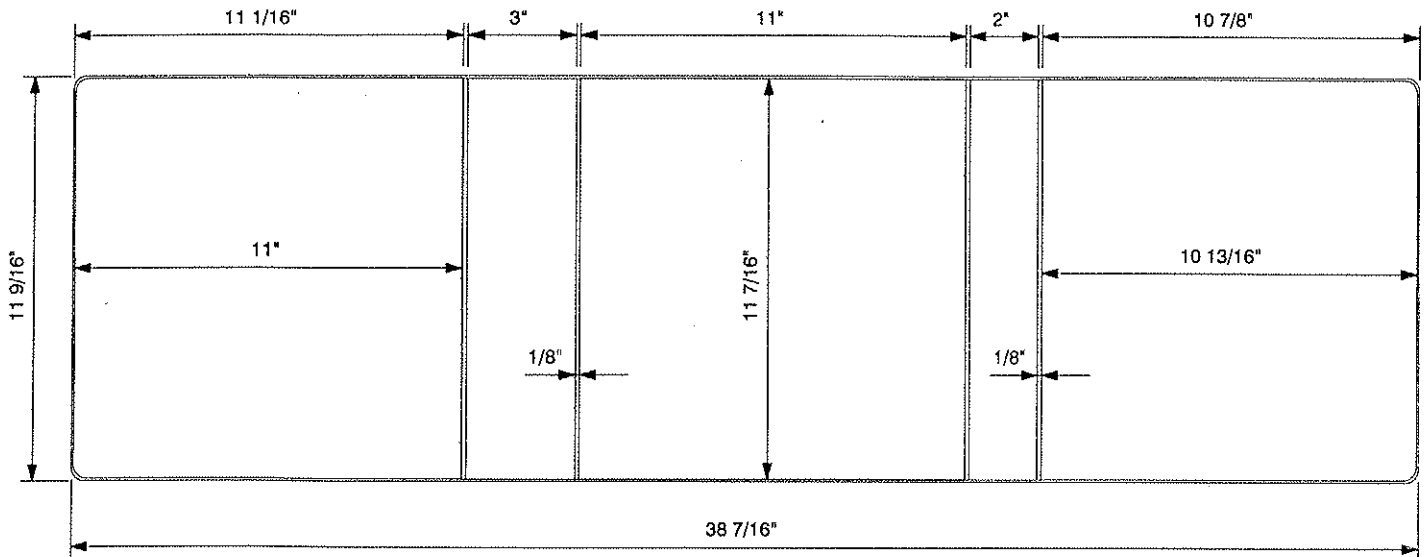

MATERIAL SPECS		GAUGE		MATERIAL SPECS		GAUGE	
COVER MAT.	12 5/16 X 39 1/2		1	LINING MAT.	12 5/16 X 39 1/2		1
COVER MAT.				LINING MAT.			
DIE CUT				HORZ. PKT.			
APPLIQUE	13X6			VERT. PKT.			
LABEL HOLDER				DIE CUT			
GUSSET				REINF.			

BOARD SPECS		GAUGE		BOARD SPECS		GAUGE	
F.C. BOARD	11 11/32 X 10 29/32	120	1	F.C. BOARD			
B.B. BOARD	11 11/32 X 2 29/32	120	1	B.B. BOARD			
B.C. BOARD	11 11/32 X 10 29/32	120	1	B.C. BOARD			
BOARD	11 11/32 X 1 29/32	120	1	DIE CUT			
BOARD	11 11/32 X 10 23/32	120	1	DIE CUT			

DIE #	6398	METAL	RR LOC W/B	RADIUS	3/8"
ORDER.#	988861	CUSTOMER	STANDARD MOTOR	TEAR SEAL	.010
SHEET SIZE		STYLE CASE	VRB TRIFOLD	BAR SEAL	178-253
CAP.	1"	DUE DATE	1-12-97	COMPLETED	
LOCATION	L-2-8	QUANTITY	100	DATE	12-22-9

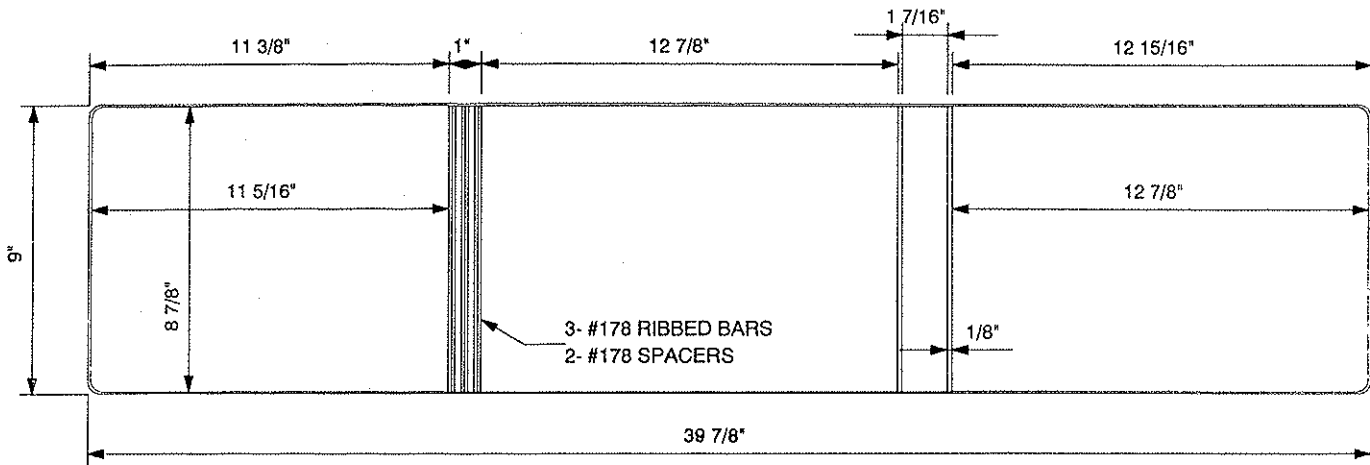

MATERIAL SPECS		GAUGE PCS.		MATERIAL SPECS		GAUGE	
COVER MAT.	9 3/4 X 40 7/8		1	LINING MAT.	9 3/4 X 40 7/8		
COVER MAT.				LINING MAT.			
DIE CUT				HORZ. PKT.			
COL				VERT. PKT.			
LABEL HOLDER				DIE CUT			
GUSSET				REINF.			

BOARD SPECS		GAUGE PCS.		BOARD SPECS		GAUGE	
F.C. BOARD	8 13/16 X 12 13/16	100	1	F.C. BOARD			
B.B. BOARD	8 13/16 X 1 11/32	100	1	B.B. BOARD			
B.C. BOARD	8 13/16 X 12 13/16	100	1	B.C. BOARD			
FLAP BD.				DIE CUT			
BOARD	8 13/16 X 1 11/32 <i>Red flex</i>	50	1	DIE CUT			

DIE #	6475-A-R	METAL	NONE	RADIUS	5/16"
ORDER #	989684	CUSTOMER	PEPPERTREE	TEAR SEAL	NAT EDGE
SHEET SIZE	11 X 8 1/2	STYLE CASE	TRIFOLD	BAR SEAL	
CAP.		DUE DATE	4-3-98	COMPLETED	
LOCATION		QUANTITY	5000	DATE	4-1-98

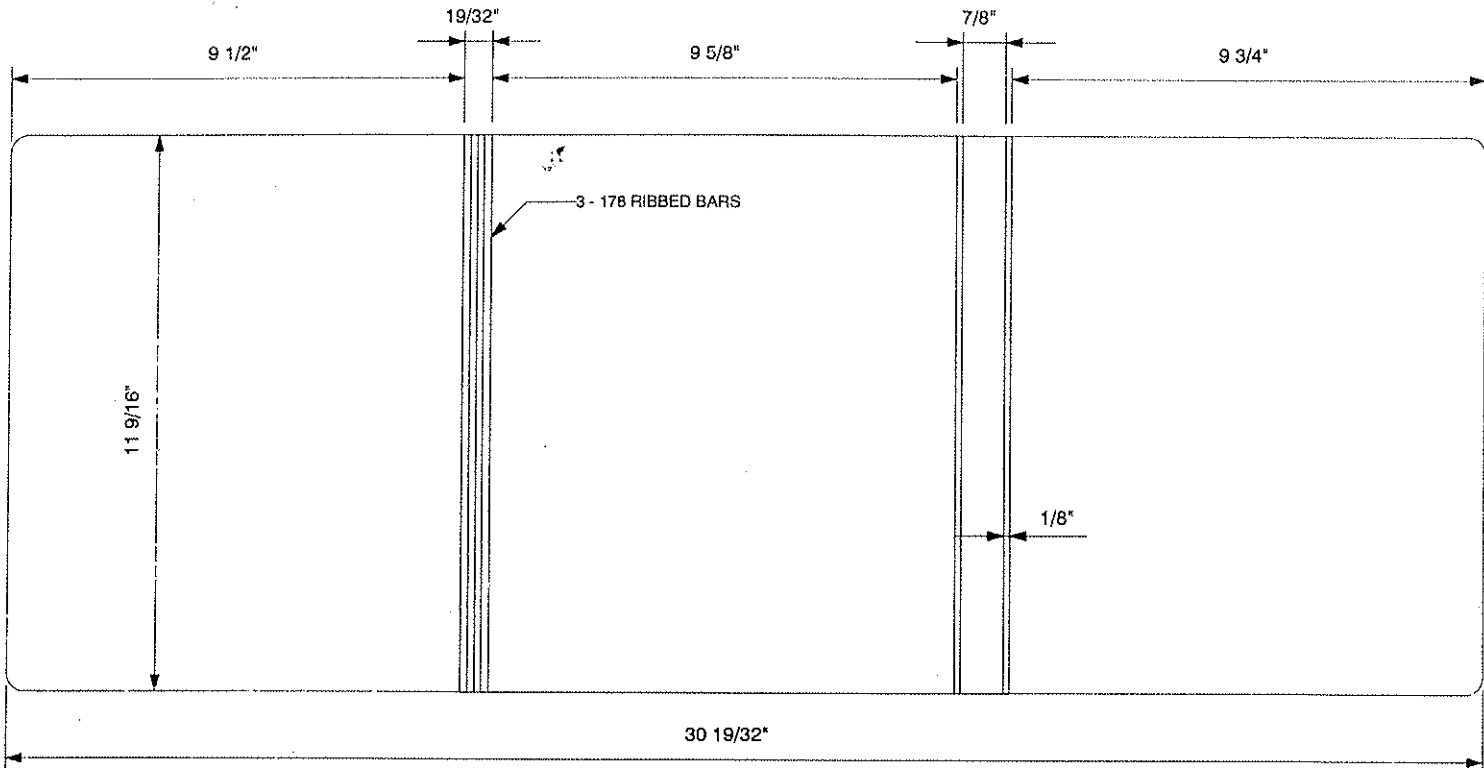

MATERIAL SPECS		GAUGE		MATERIAL SPECS		GAUGE	
COVER MAT.	12 9/16 X 31 5/8		1	LINING MAT.	12 3/8 X 31 3/8		1
COVER MAT.				LINING MAT.			
DIE CUT				HORZ. PKT.	8 3/8 X 31 3/8		1
COL				HORZ. PKT.	7 3/8 X 31 3/8		1
LABEL HOLDER				DIE CUT			
GUSSET				REINF.			

BOARD SPECS		GAUGE		BOARD SPECS		GAUGE	
F.C. BOARD	11 3/8 X 9 5/8	100	1	F.C. BOARD			
B.B. BOARD	11 3/8 X 25/32	100	1	B.B. BOARD			
B.C. BOARD	11 3/8 X 9 17/32	100	1	B.C. BOARD			
FLAP BD.	11 3/8 X 9 3/8	100	1	DIE CUT			
BOARD				DIE CUT			

DIE #	6696	METAL		RADIUS	3/8"
ORDER #	234915	CUSTOMER	MEMBERWORKS INC	TEAR SEAL	.012
SHEET SIZE	10 X 5 - QA	STYLE CASE	VINYL TRIFOLD	BAR SEAL	178
CAP.		DUE DATE	5-5-99	COMPLETED	
LOCATION	1-12-6	QUANTITY	2	DATE	4-29-99

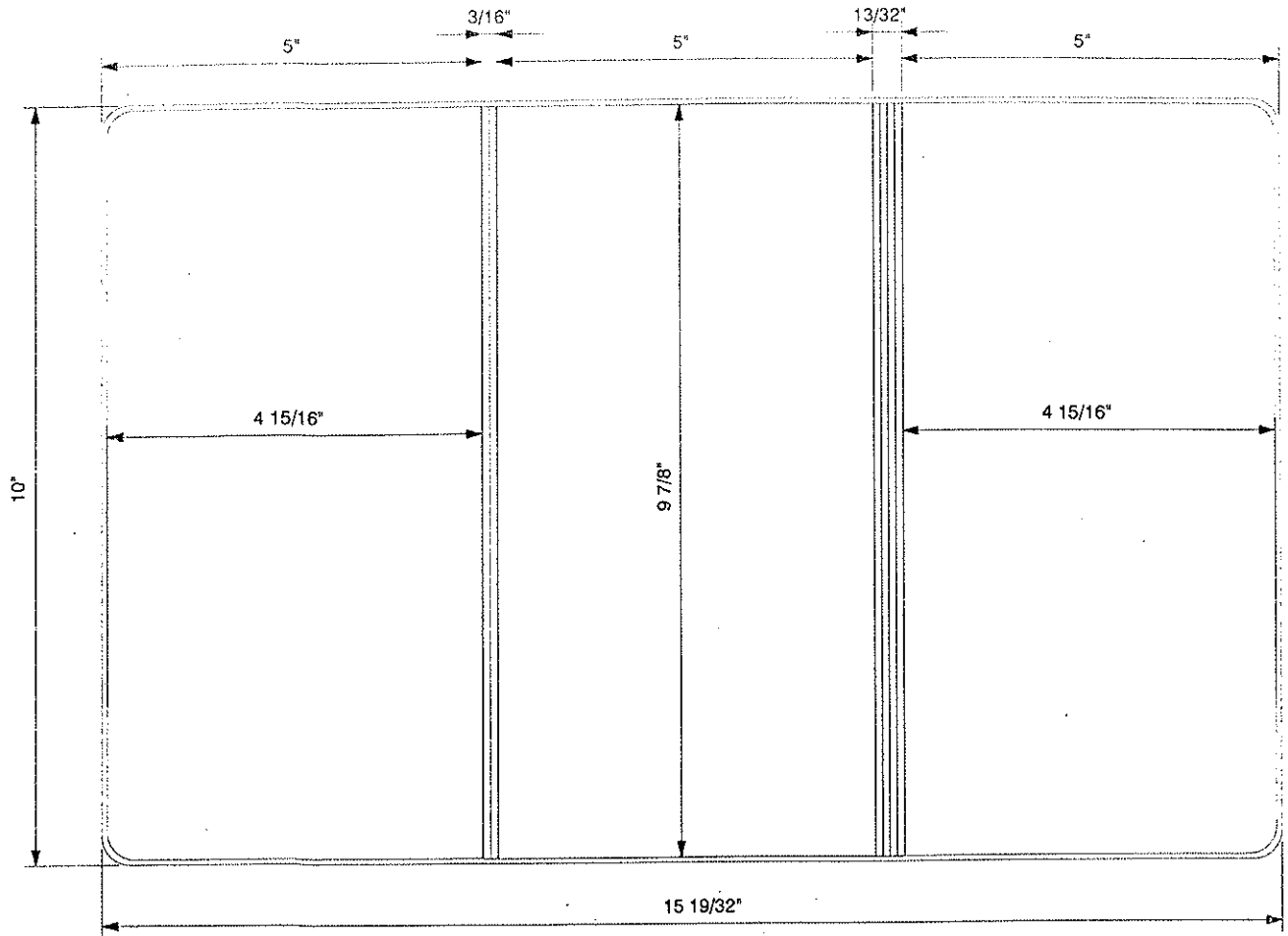

MATERIAL SPECS		GAUGE	PCS.	MATERIAL SPECS		GAUGE	PCS.
COVER MAT.	10 3/4 X 16 3/8		1	LINING MAT.	10 3/4 X 16 3/8		1
COVER MAT.				LINING MAT.			
DIE CUT				HORZ. PKT.	4 5/8 X 16 3/8		1
COL				VERT. PKT.			
LABEL HOLDER				DIE CUT			
GUSSET				REINF.			

BOARD SPECS		GAUGE	PCS.	BOARD SPECS		GAUGE	PCS.
	5/16" R. CORNERS				5/16" R. CORNERS		
F.C. BOARD	9 13/16 X 4 7/8	100	1	F.C. BOARD			
B.B. BOARD	9 13/16 X 4 15/16	100	1	B.B. BOARD			
B.C. BOARD	9 13/16 X 4 7/8	100	1	B.C. BOARD			
FLAP BD.				DIE CUT			
BOARD				DIE CUT			

DIE #	6749	METAL		RADIUS	1/4"
ORDER #	260291	CUSTOMER	ALLSTATE INSURANCE	TEAR SEAL	.014
SHEET SIZE	11.5 X 32.75	STYLE CASE	VINYL TRIFOLD FOLDER	BAR SEAL	178
CAP.		DUE DATE	8-14-99	COMPLETED	
LOCATION	H-8-2	QUANTITY	2500	DATE	8-20-99

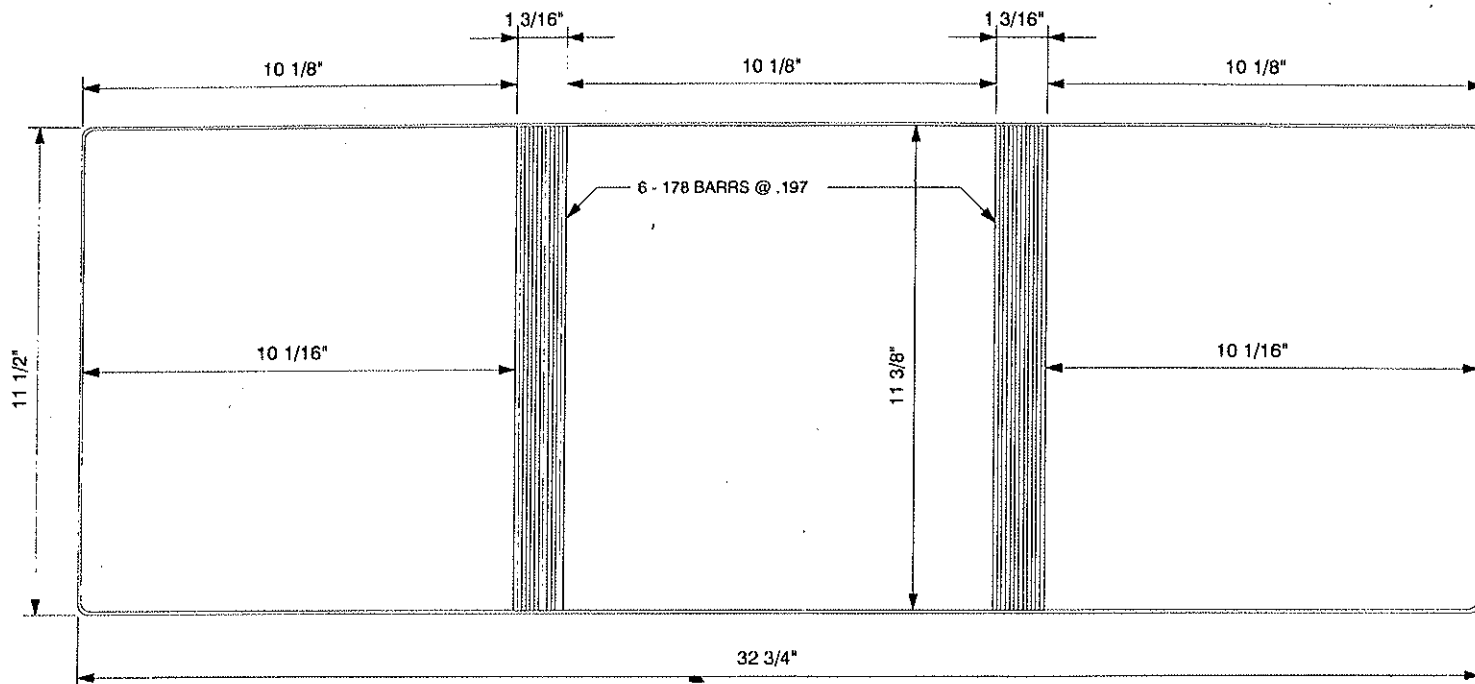

MATERIAL SPECS		GAUGE	PCS.	MATERIAL SPECS		GAUGE	PCS.
COVER MAT.	12 1/2 X 33 3/4		1	LINING MAT.	12 1/4 X 33 1/2		1
COVER MAT.				HORZ. PKT.	5 3/8 X 33 1/2		1
DIE CUT				HORZ. PKT.	5 1/8 X 10 5/8		1
COL				HORZ. PKT.	5 3/8 X 10 5/8		1
LABEL HOLDER				HORZ. PKT.	3 X 5 3/4		1
GUSSET				PEN LOOP	1 X 2		1
BOARD SPECS		GAUGE	PCS.	BOARD SPECS		GAUGE	PCS.
F.C. BOARD	11 5/16 X 10		100	F.C. BOARD	5/16" R. CORNERS		
B.B. BOARD	11 5/16 X 10 1/16		100	B.B. BOARD			
B.C. BOARD	11 5/16 X 10		100	B.C. BOARD			
FLAP BD.				DIE CUT			
BOARD				DIE CUT			

DIE #	6894	METAL		RADIUS	
ORDER #	329800	CUSTOMER	NEW AMERICAN PRINTING	TEAR SEAL	.010
SHEET SIZE		STYLE CASE	VINYL TRIFOLD	BAR SEAL	178-102
CAP.		DUE DATE	4-27-00	COMPLETED	
LOCATION		QUANTITY	2500	DATE	4-10-00

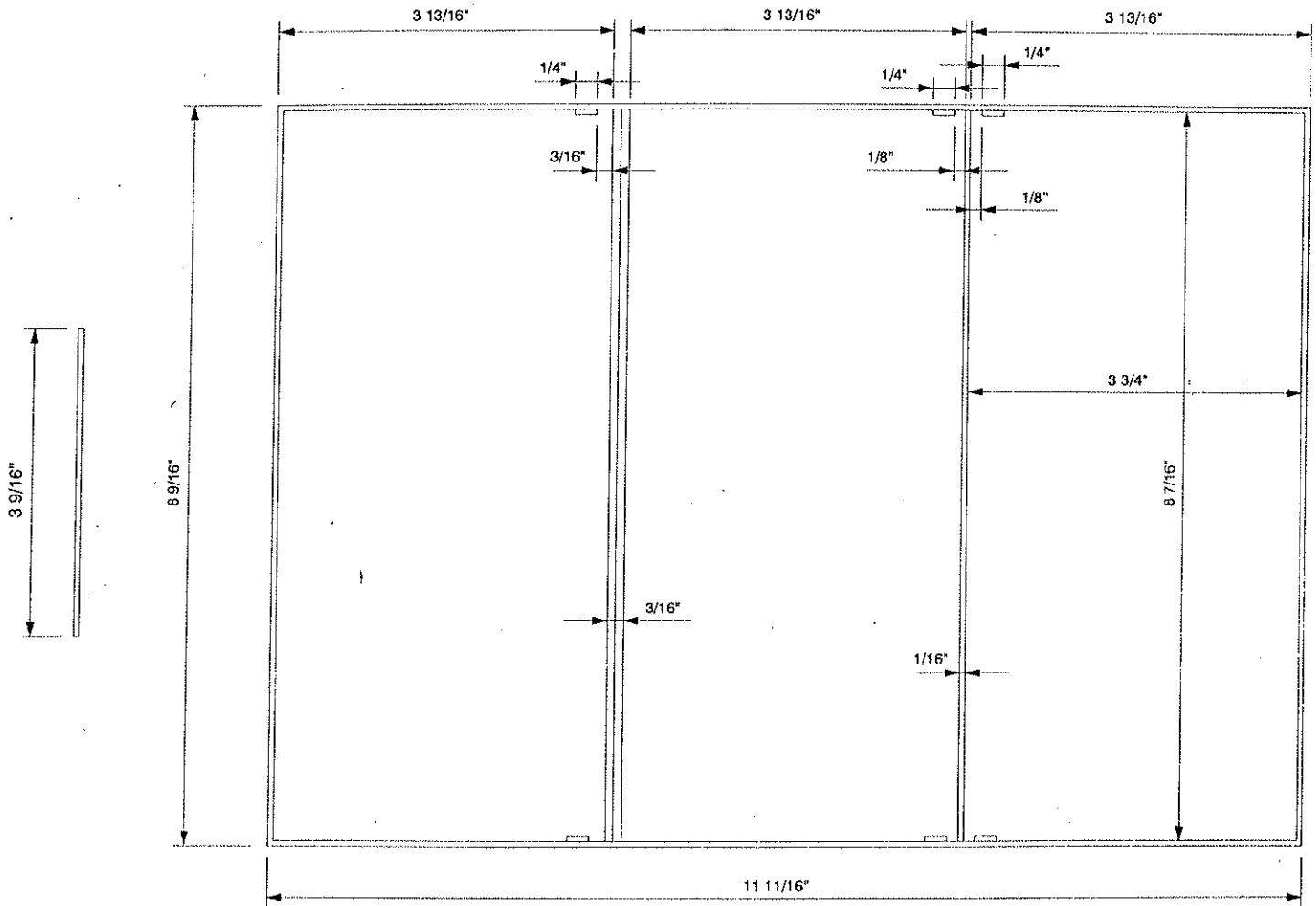

MATERIAL SPECS		GAUGE	PCS.	MATERIAL SPECS		GAUGE	PCS.
COVER MAT.	9 5/16 X 12 7/16		1	LINING MAT.	9 5/16 X 4		1
COVER MAT.				LINING MAT.	9 5/16 X 4 1/16		1
DIE CUT				HORZ. PKT.	9 5/16 X 3 3/4		1
COL				VERT. PKT.	9 5/16 X 3 13/16		1
LABEL HOLDER				DIE CUT			
GUSSET				REINF.			

BOARD SPECS		5/16" R. CORNERS	GAUGE	PCS.	BOARD SPECS		5/16" R. CORNERS	GAUGE	PCS.
F.C. BOARD					F.C. BOARD				
B.B. BOARD					B.B. BOARD				
B.C. BOARD					B.C. BOARD				
FLAP BD.					DIE CUT				
BOARD					DIE CUT				

DIE #	6983-A	METAL	RADIUS	3/8"	
ORDER #	368833	CUSTOMER	AURORA CASKET CO.	TEAR SEAL	.010
SHEET SIZE		STYLE CASE	VINYL SWATCH BOOK	BAR SEAL	48-3
CAP.		DUE DATE	10-4-00	COMPLETED	
LOCATION		QUANTITY	100	DATE	9-25-00

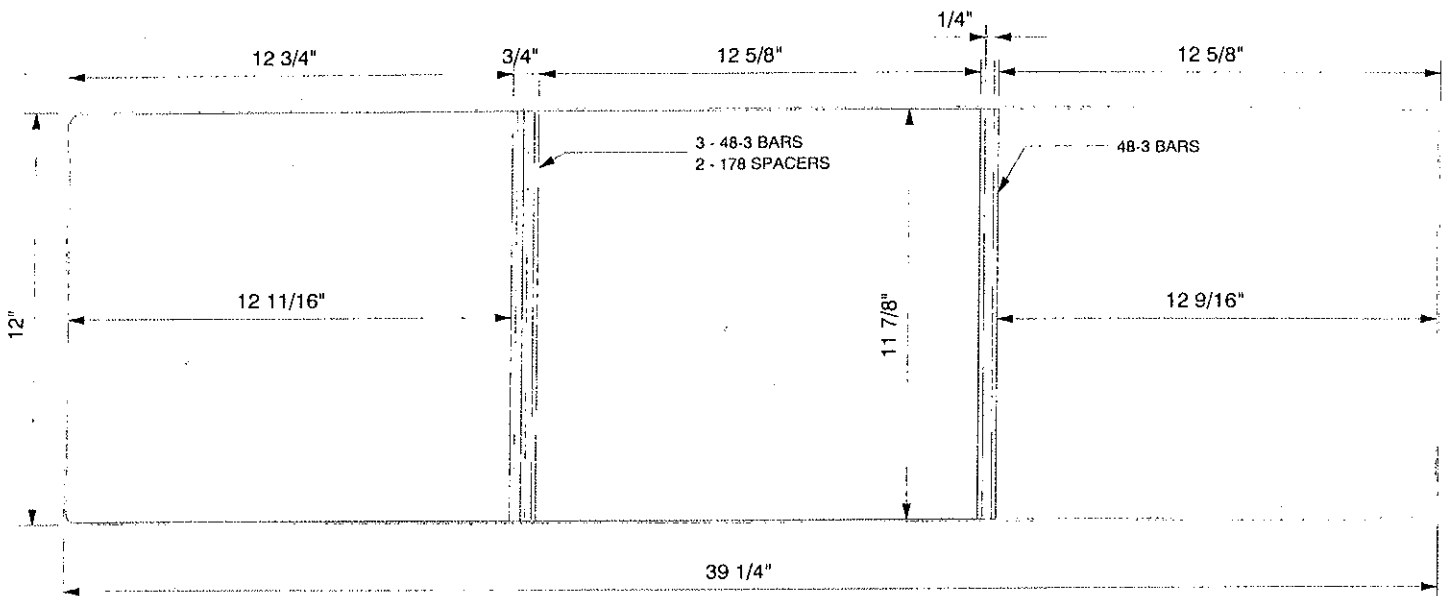

MATERIAL SPECS		GAUGE	PCS.	MATERIAL SPECS		GAUGE	PCS.
COVER MAT.	13 X 40 1/4		1	LINING MAT.	13 X 40 1/4		1
COVER MAT.				LINING MAT.			
DIE CUT				HORZ. PKT.			
COL				VERT. PKT.			
LABEL HOLDER				DIE CUT			
GUSSET				REINF.			
BOARD SPECS		GAUGE	PCS.	BOARD SPECS		GAUGE	PCS.
F.C. BOARD	11 13/16 X 12 5/8	100	1	F.C. BOARD	5/16" R. CORNERS		
B.B. BOARD	11 13/16 X 12 9/16	100	1	B.B. BOARD			
B.C. BOARD	11 13/16 X 12 1/2	100	1	B.C. BOARD			
FLAP BD.				DIE CUT			
BOARD				DIE CUT			

DIE #	7063-A	METAL		RADIUS	3/8
ORDER #	407290	CUSTOMER	MINI VACATIONS	TEAR SEAL	.014
SHEET SIZE	12 X 9.5 OA	STYLE CASE	VINYL TRI-FOLD BINDER	BAR SEAL	102
CAP.		DUE DATE	2-22-01	COMPLETED	
LOCATION		QUANTITY	2500	DATE	2-14-01

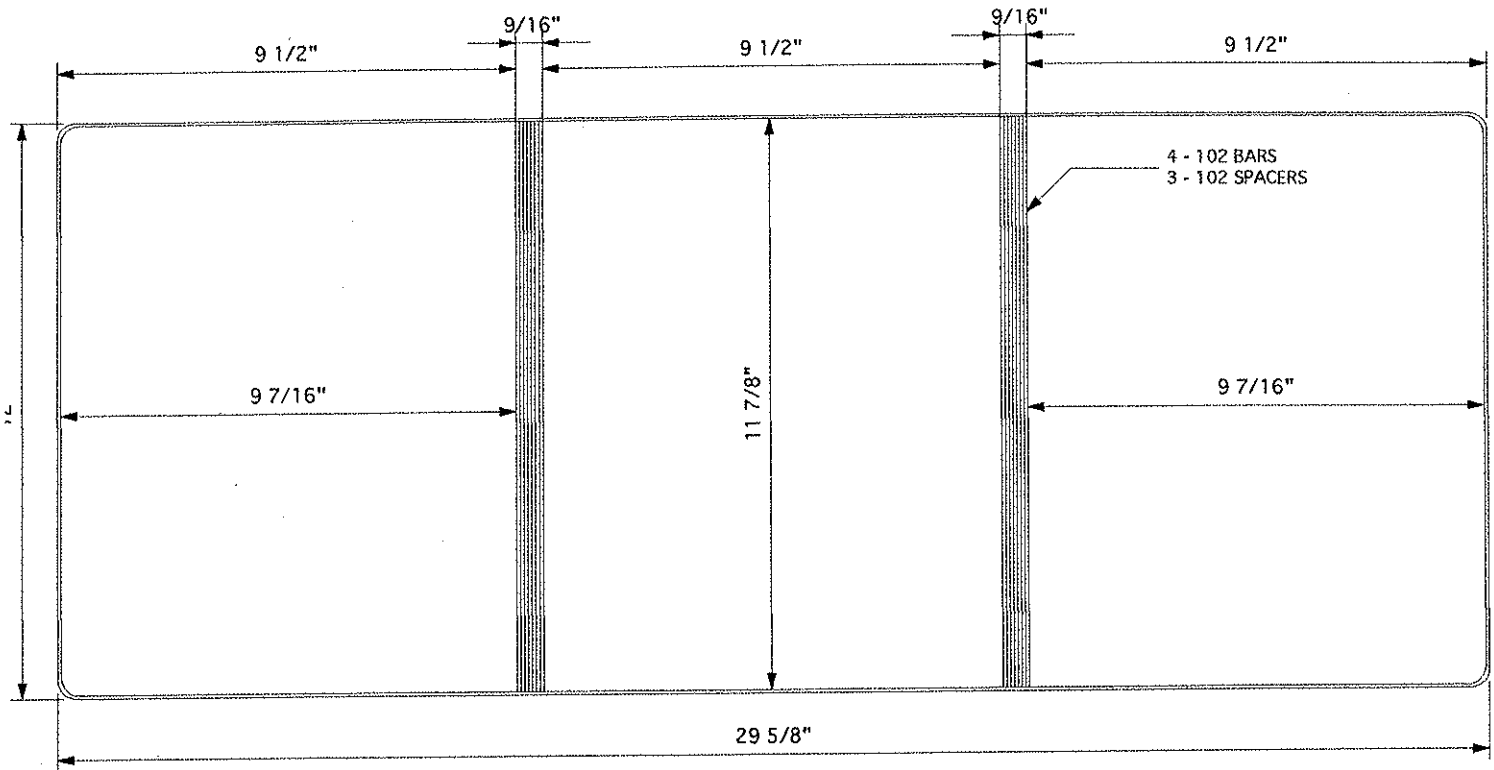

MATERIAL SPECS		GAUGE	PCS.	MATERIAL SPECS		GAUGE	PCS.
COVER MAT.	13 X 30 5/8		1	LINING MAT.	12 3/4 X 30 3/8		1
COVER MAT.				LINING MAT.			
DIE CUT				HORZ. PKT.	5 7/8 X 30 3/8		1
COL				VERT. PKT.			
LABEL HOLDER				DIE CUT			
GUSSET				REINF.			
BOARD SPECS		5/16" R. CORNERS		BOARD SPECS		5/16" R. CORNERS	
F.C. BOARD	PADDED FC DIECUT 7063-B			F.C. BOARD			
B.B. BOARD	11 25/32 X 9 13/32	100	1	B.B. BOARD			
B.C. BOARD	11 25/32 X 9 11/32	100	1	B.C. BOARD			
FLAP BD.				DIE CUT			
BOARD				DIE CUT			

DIE #	7073	METAL	RADIUS	3/8	
ORDER #	415273	CUSTOMER	SPARTAN BUSINESS	TEAR SEAL	.012
SHEET SIZE	11 X 8.5	STYLE CASE	VINYL TRI-FOLD BINDER	BAR SEAL	102
CAP.		DUE DATE	3-28-01	COMPLETED	
LOCATION		QUANTITY	250	DATE	3-14-01

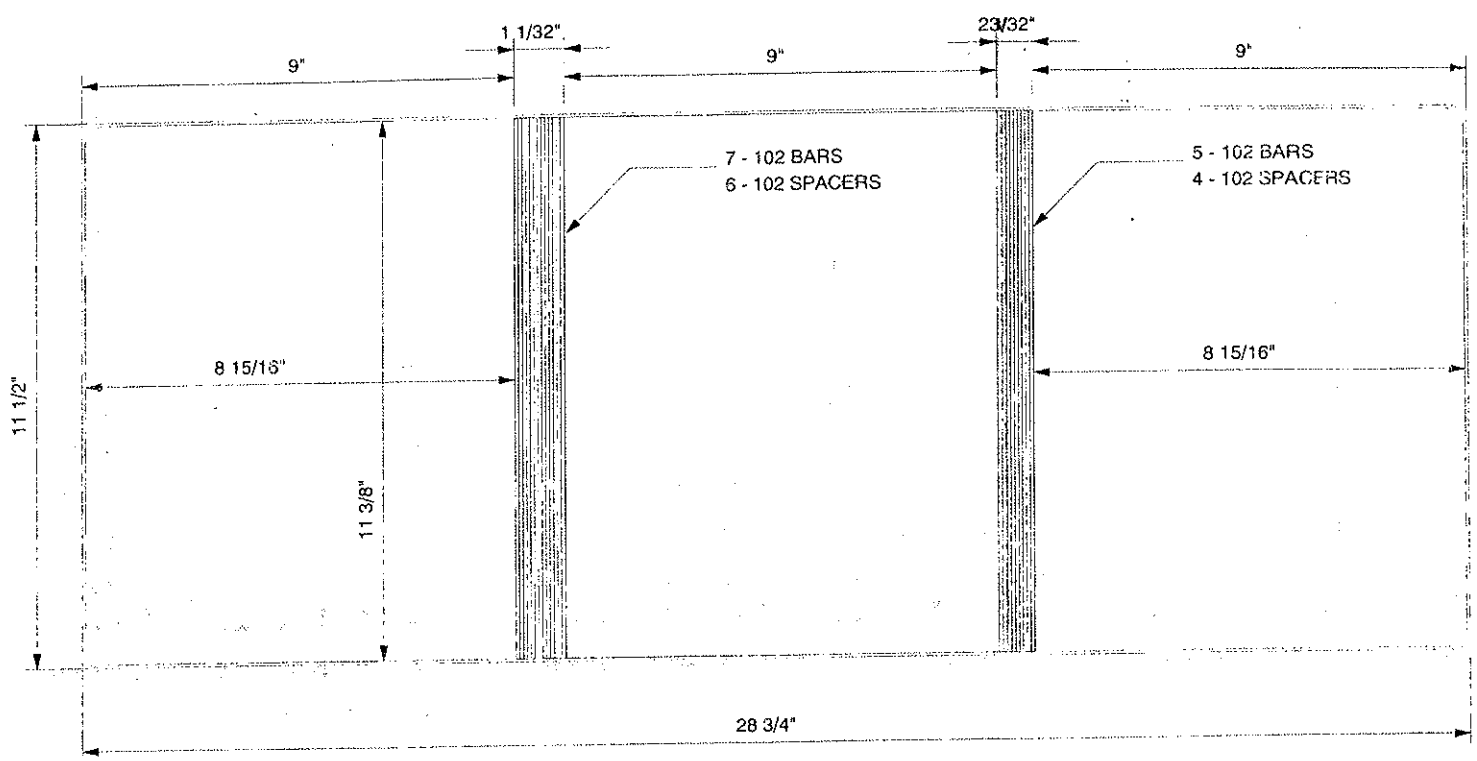

MATERIAL SPECS		GAUGE	PCS.	MATERIAL SPECS		GAUGE	PCS.
COVER MAT.	12 1/4 X 29 1/2		1	LINING MAT.	12 1/4 X 29 1/2		1
COVER MAT.				LINING MAT.			
DIE CUT				HORZ. PKT.	8 3/8 X 29 1/2		1
COL				VERT. PKT.	5 1/8 X 9 1/2		
LABEL HOLDER				DIE CUT			
GUSSET				REINF.			
BOARD SPECS	5/16" R. CORNERS	GAUGE	PCS.	BOARD SPECS	5/16" R. CORNERS	GAUGE	PCS.
F.C. BOARD	11 5/16 X 8 7/8	100	1	F.C. BOARD			
B.B. BOARD	11 5/16 X 8 15/16	100	1	B.B. BOARD			
B.C. BOARD	11 5/16 X 8 7/8	100	1	B.C. BOARD			
FLAP BD.	Die Padded Bd.			DIE CUT			
BOARD	Die 7073B 12 1/4 x 28 3/8			DIE CUT			

DIE #	8130	METAL		RADIUS	3/8"
ORDER #	729547	CUSTOMER	ORIGEN PARTNERS	TEAR SEAL	.012
SHEET SIZE	11 3/4 X 10	STYLE CASE	VINYL TRI-FOLD	BAR SEAL	.079 FLAT
CAP.		DUE DATE	5-5-06	COMPLETED	
LOCATION		QUANTITY	3000	DATE	4-24-06

*** WARNING DRAWING NOT ACTUAL SIZE ***

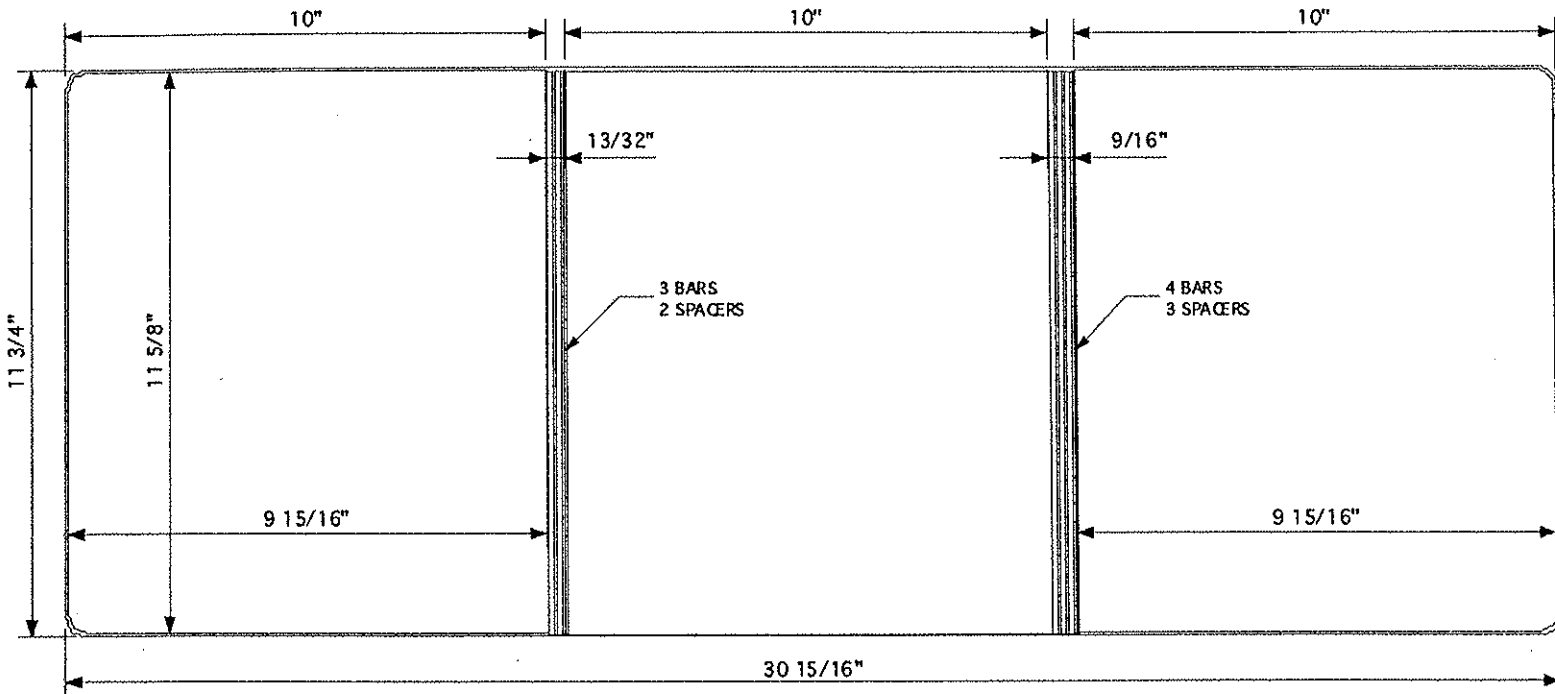

MATERIAL SPECS		GAUGE		PCS.		MATERIAL SPECS		GAUGE		PCS.					
COVER MAT.	12 1/2 X 31 3/4			1		LINING MAT.	12 1/2 X 31 3/4			1					
COVER MAT.						LINING MAT.									
DIE CUT						HORZ. PKT.									
COL						VERT. PKT.									
LABEL HOLDER						DIE CUT									
GUSSET						REINF.									
BOARD SPECS		5/16" R. CORNERS		GAUGE		PCS.		BOARD SPECS		5/16" R. CORNERS		GAUGE		PCS.	
F.C. BOARD	11 9/16 X 9 13/16	98	2	F.C. BOARD				F.C. BOARD							
B.B. BOARD	11 9/16 X 9 7/8	98	1	B.B. BOARD				B.B. BOARD							
B.C. BOARD				B.C. BOARD				B.C. BOARD							
FLAP BD.				DIE CUT				DIE CUT							
STEEL	11 1/4 X 9 7/16	.04	3	DIE CUT				DIE CUT							