



WINGSCAPES

150 Industrial Road  
Alabaster, AL 35007

**Customer Support**

Phone: 888.811.WING (9464)  
Fax: 205.408.6157

**Find Us Online**

Website: [wingscapes.com](http://wingscapes.com)  
YouTube: [youtube.com/wingscapes](http://youtube.com/wingscapes)  
Blog: [wingscapes.com/blog](http://wingscapes.com/blog)

(Monday - Friday, 9am - 4:30pm CST)  
Web: [wingscapes.com/contactus](http://wingscapes.com/contactus)  
Email: [customerservice@wingscapes.com](mailto:customerservice@wingscapes.com)

Facebook: [facebook.com/wingscapes](http://facebook.com/wingscapes)  
Twitter: [@wingscapes](https://twitter.com/wingscapes)

---

## Wingscapes AutoFeeder User Guide

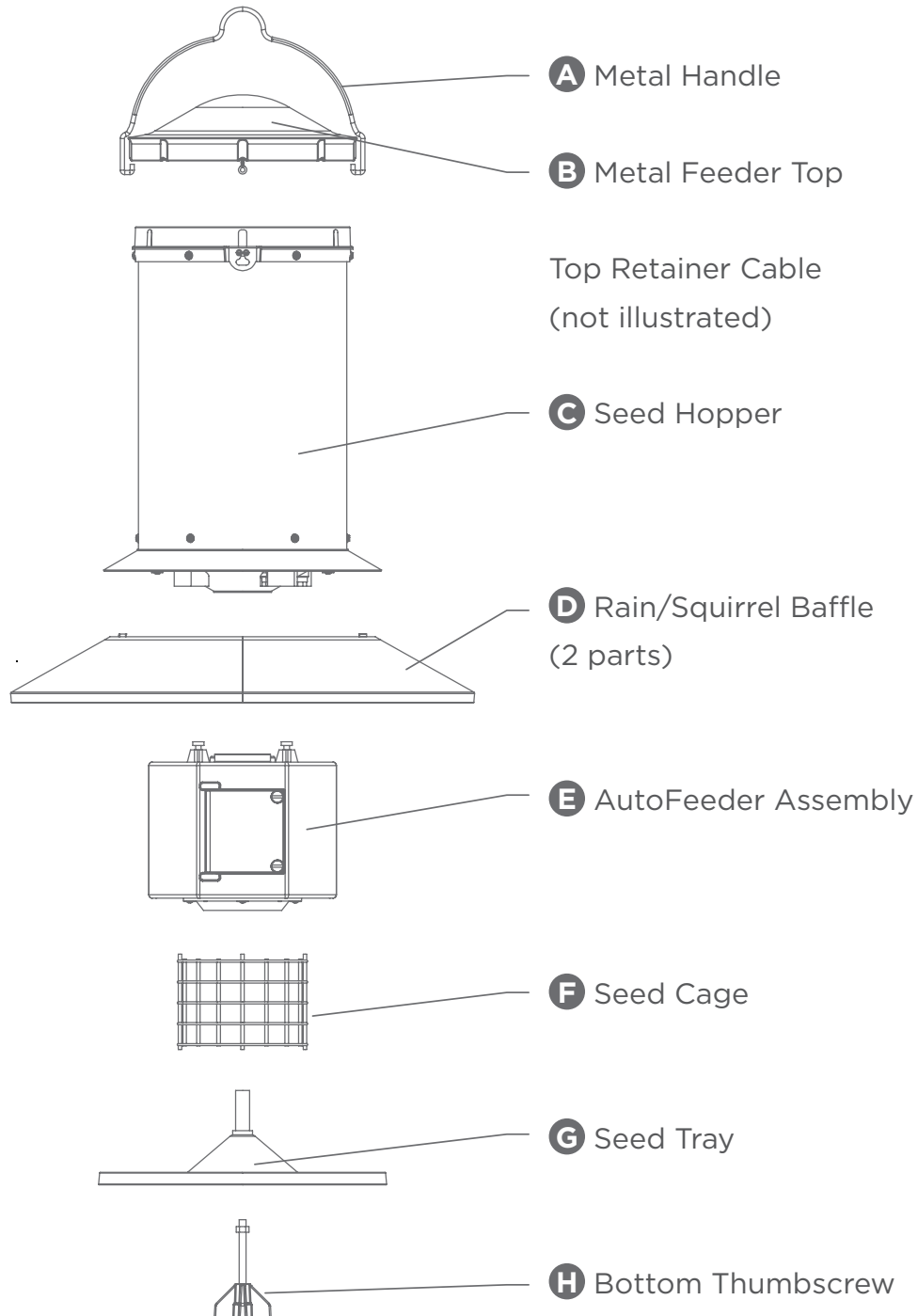

## Assemble AutoFeeder

1. Join the (2) rain baffle parts **D** by snapping them together.
  2. Attach the assembled rain baffle to the bottom of the seed hopper **C**. Insert 4 posts on the hopper into 4 holes in the rain baffle, and rotate until they “snap” into place.
  3. Attach the AutoFeeder Assembly **E** to the bottom of the seed hopper. Align 4 posts in the AutoFeeder Assembly with the 4 holes in the bottom of the seed hopper. Rotate until they “snap” into place.
  4. Attach the seed cage **F** and seed tray **G** to the bottom of the AutoFeeder assembly using the large thumb screw **H**. Finger tighten the thumb screw. Do not over tighten.
- 

## Install Batteries

5. Loosen the metal thumb screws on the battery compartment door and temporarily remove the door. Install 4 AA alkaline or lithium batteries (not included) in the proper direction shown in each of the battery positions. Do not mix alkaline batteries with lithium or other rechargeable batteries (fig.1).
  6. Replace the battery door. Finger tighten the 2 thumb screws to secure the battery door. Do not over tighten.
- 

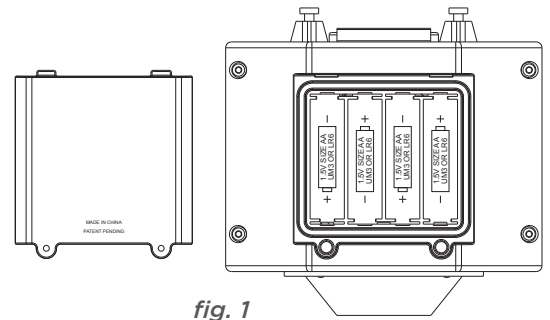

## Fill Your Feeder

7. Move metal handle **A** to the down position and remove the metal top.
- B** Fill the seed hopper with your seed of choice and replace metal top. Move metal handle to the up position.

## Set the Timer

**8.** Loosen the 2 metal thumb screws and open the timer door (fig 2).

**Set Time of Day:** Press UP or DOWN button to set hour and minute to current time.

**Set Feed Times:** Press MODE button until desired Timer number (1-4) appears in the lower right hand corner of display. Press the UP or DOWN button to adjust the Timer. See below section: "Set Run-Time" to customize the amount of seed dispensed by each Timer.

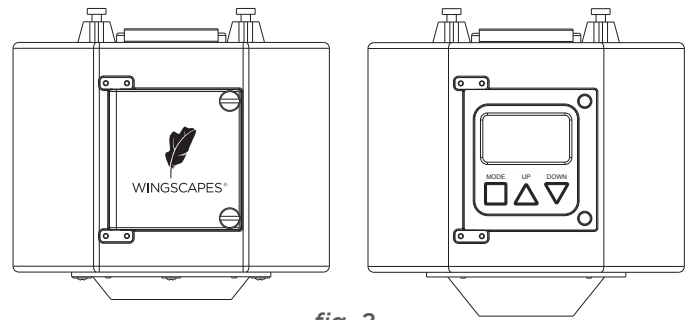

fig. 2

**Set Run-Time:** Press the MODE button again to display Run-Time. Press the UP or DOWN button to adjust the Run-Time from 0 and 20 seconds.

(The longer the Run-Time, the more seed will be dispensed. Figure about 1/2 ounce per second, depending on seed type.) To disable a Timer, set Run-Time to 0 seconds.

**Manual Operation / Run-Time Test:** To test the amount of seed dispensed by a given Run-Time, or to manually dispense seed, do the following: while the Run-Time is displayed, press and hold the MODE button for about 3 seconds to start a test. Release MODE button. After a 5 second countdown, the feeder will run for the number of seconds programmed.

**9.** Close timer door and finger tighten the 2 thumb screws to secure door. Do not over tighten.

.....

## Start Feeding

**10.** Hang the AutoFeeder and let the feeding begin!

.....

## Maintenance and Care

**11.** Do not run water through the inside AutoFeeder assembly. To clean, remove the AutoFeeder assembly from the seed hopper. Use clean water to rinse out seed hopper and dry with soft clean towel.

## Customer Support

WINGSCAPES  
150 Industrial Road  
Alabaster, AL 35007  
wingscapes.com  
1-888-811-WING (9464)