

Instruction Sheet

Models ATV-56, ATV-56B, ATV-56C & ATV-56BC



LUXOR
 2245 Delany Road
 Waukegan, IL 60087
 Ph: 847/244-1800 • 1-800-323-4656
 Fax: 847/244-1818 • 1-800-327-1698



ATV56

Parts List

- | | |
|---------------------------|--|
| 1 - Top Stand Assembly | 8 - Bolts |
| 1 - Bottom Stand Assembly | 8 - Nuts |
| 1 - Rubber Mat | 1 - Power Cord Assembly
With Hardware |
| 4 - 4" Casters, 2 w/brake | |

- For model ATV56C, ATV56BC**
- 2 - Keys
 - 2 - Chrome Recessed Handles
 - 4 - Black Screws

- Tools Required**
- 1 - Slotted Screwdriver
 - 1 - Rubber Mallet

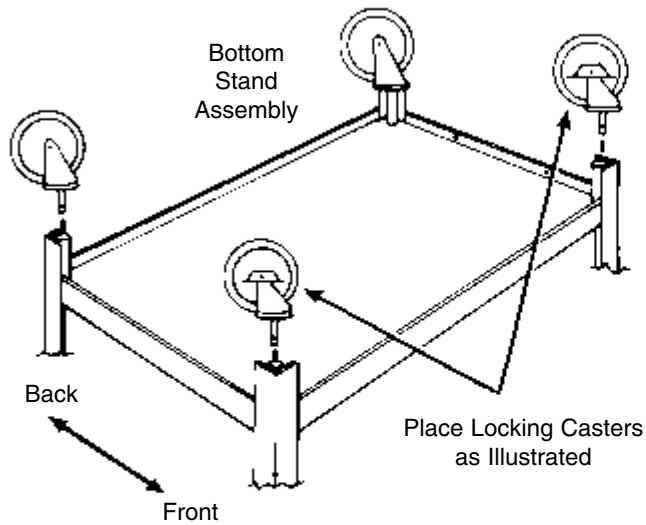

1. Turn bottom stand assembly upside down on a smooth surface. Push the four casters firmly into the caster socket holes in bottom of each leg, as illustrated.

IMPORTANT: Casters must be fully seated. Tap firmly with a rubber mallet properly seat casters. Turn the bottom stand right side up.

For Big Wheel Models

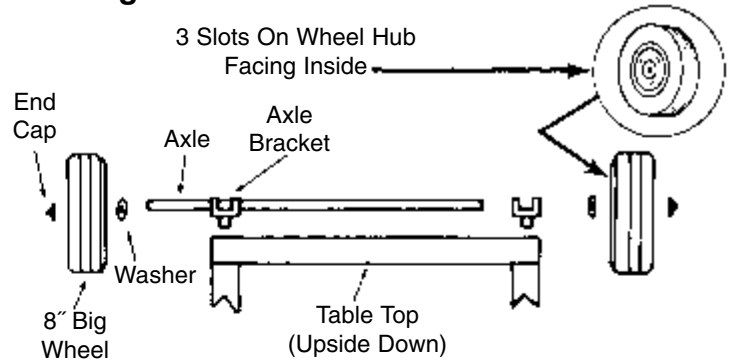

2. The big wheel is to be installed along the most narrow side of the table. Install axle brackets as illustrated. Tap one axle cap onto one end of the axle and slide the big wheel onto the axle from the opposite end. Slide one washer onto axle so it rests against the big wheel. Install axle by sliding it through axle brackets so that big wheel is resting against side of bracket. Slide washer onto the open side of the axle and then slide the remaining big wheel into place.

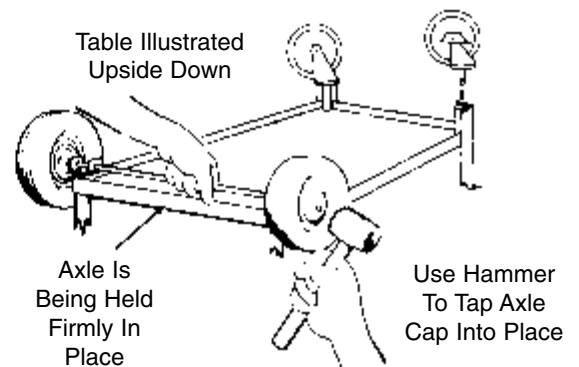

Tap remaining axle cap onto axle end. Big wheels should be snug fit with little side-to-side play. Push the two locking casters firmly into the holes in the front of the cart. **Important:** Casters must be fully seated. Tap firmly with rubber mallet.

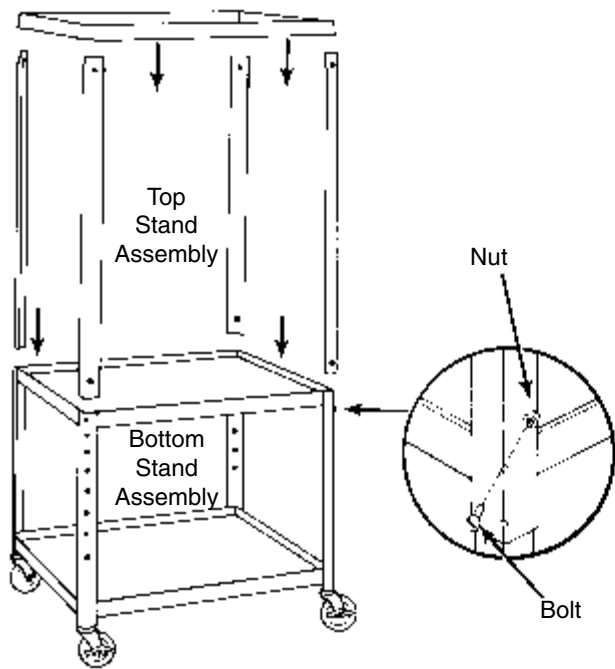

3. Position top stand assembly over bottom stand assembly as illustrated.

Adjust top stand assembly up or down to desired height. Align holes in all four legs, insert bolts and fasten with four wing nuts, as illustrated.

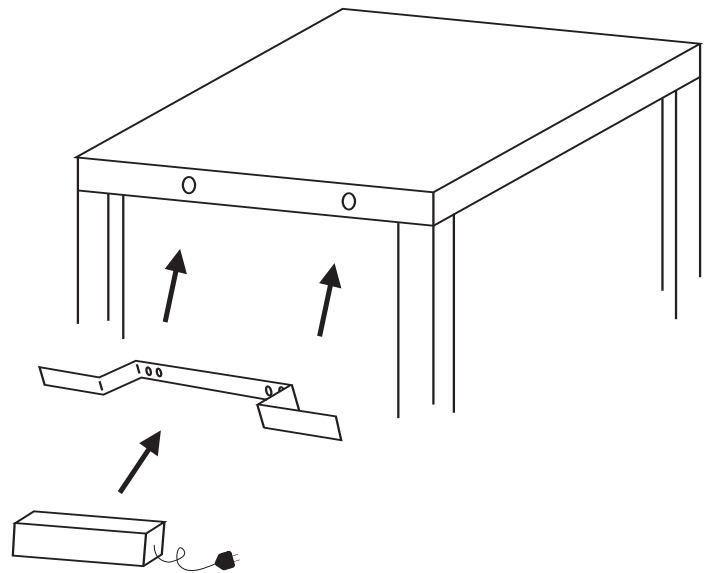

4. Place metal cordwrap onto metal top shelf making sure that the holes on the cordwrap align with the holes on the shelf. Place the two screws through the holes of the electrical assembly. Place the electrical assembly with the two screws through the holes of the cordwrap and mounting bracket. Secure screws with wingnuts.

Cabinet Models Only

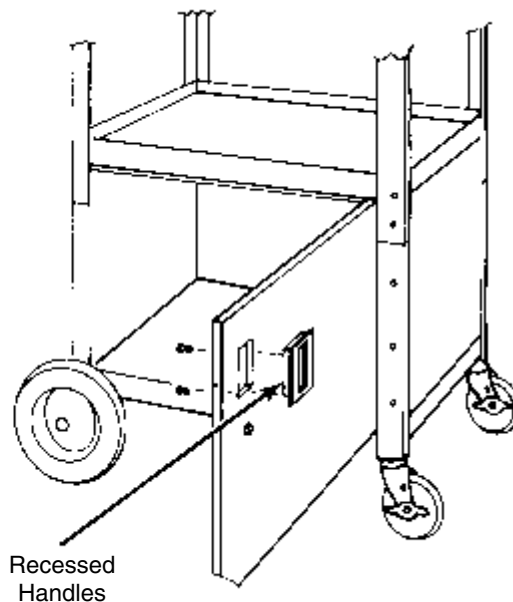

For Models With a Cabinet

5. Press recessed handle into door and fasten with 2 phillips head screws.