

Instruction Sheet

Models AVJ-42, AVJ-42C



Customer Service Dept
 2245 Delany Rd
 Waukegan, IL 60087
 Ph: 847/244-1800 • 800/323-4656
 Fax: 847/244-1818 • 800/327-1698



AVJ42



AVJ-42C

Parts List

Models AVJ-42, AVJ-42C

- 4 - 4" casters, 2 w/brake
- 4 - bolts
- 4 - Kep nuts
- 1 - Electric Assembly with Hardware

1 - rubber mat

Tools Required:

- 1 - slotted screwdriver
- 1 - rubber mallet

For Cabinet Models Only:

- 2 - keys

1

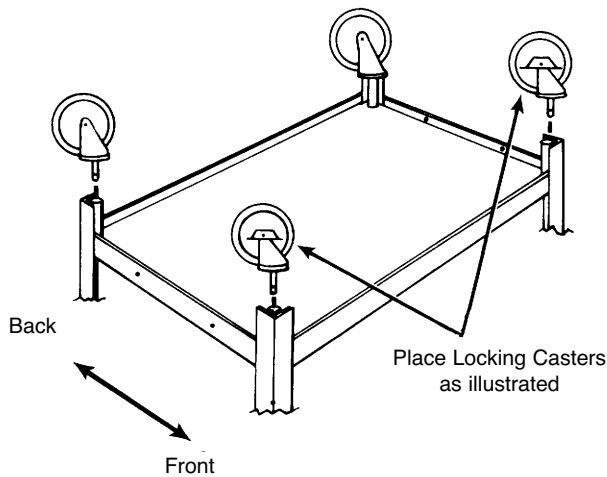

Turn bottom stand assembly upside down on a smooth surface. Push the four casters firmly into the caster socket holes in bottom of each leg as illustrated.

IMPORTANT: Casters must be fully seated. Tap with rubber mallet firmly to properly seat casters. Turn the stand right side up.

2

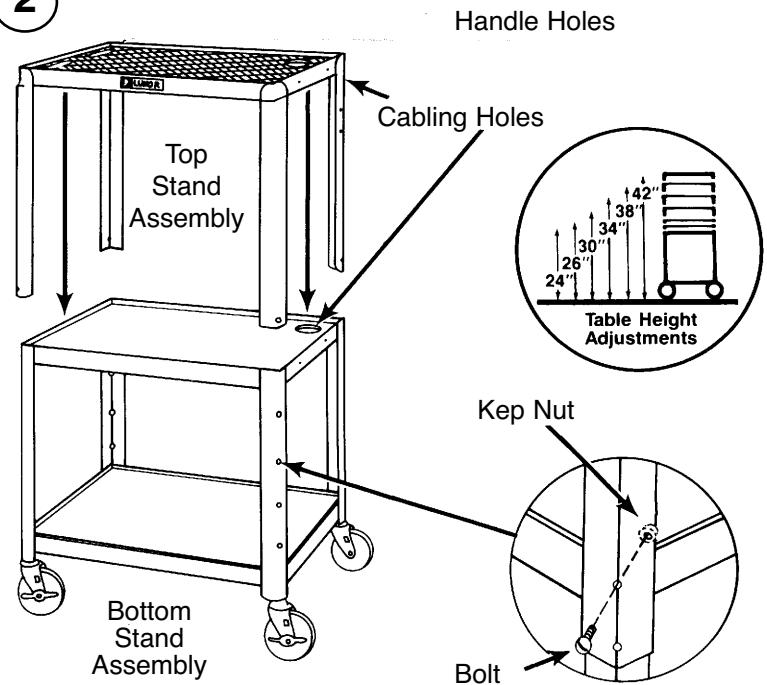

Position top stand assembly over bottom stand assembly, as illustrated.

NOTE: Be sure cabling hole in corner of top and middle shelves line up on top of each other.

Adjust top stand assembly up or down to desired height. Align holes in all four legs, insert bolts and fasten with four Kep nuts, as illustrated.

3

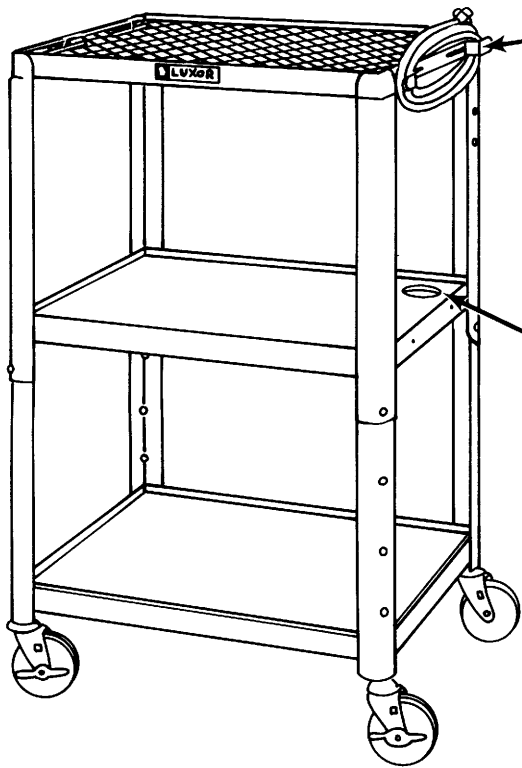

Cabling Hole

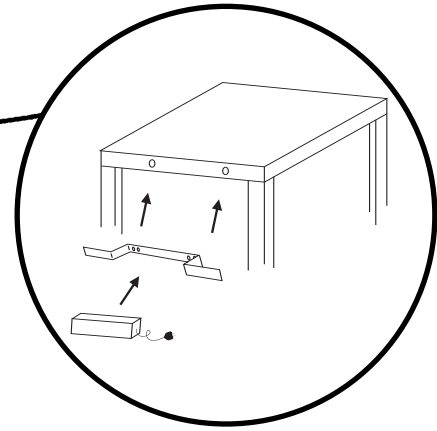

Place metal cordwrap onto metal top shelf making sure that the holes on the cordwrap align with the holes on the shelf. Place the two screws through the holes of the electrical assembly. Place the electrical assembly with the two screws through the holes of the cordwrap and mounting bracket. Secure screws with wingnuts.

4

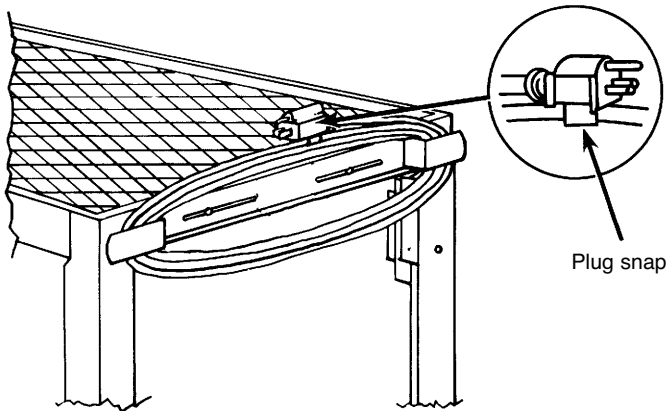

Plug snap

For safety and neat appearance, secure cord plug to cord with plug snap, place rubber mat on top shelf.

5

CABINET MODELS ONLY

