

# Instruction Sheet

## Model AVJ422KB4



Customer Service Dept  
 2245 Delany Rd  
 Waukegan, IL 60087  
 Ph: 847/244-1800 • 800/323-4656  
 Fax: 847/244-1818 • 800/327-1698



AVJ422KB4

PARTS LIST FOR SHELF ASSEMBLY	
8 -	L-brackets
8 -	Washers
8 -	Bolts
8 -	Nuts
8 -	Self tapping screws
32 -	Sheet metal screws
4 -	Runners
2 -	Keyboard Shelf Racks

### Step 1 MOUSE SHELF ASSEMBLY

(Note: For the mouse shelf to pull out to the right, use the first set of holes on the left side and the third set of holes.)

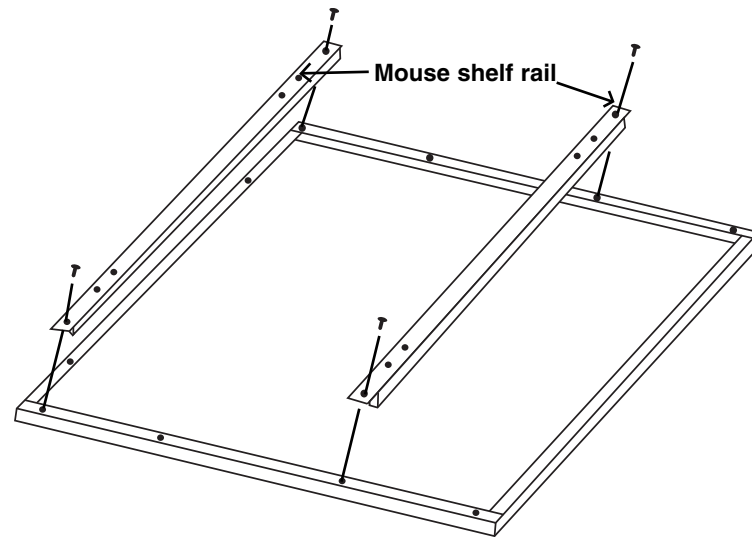

Attach the mouse shelf support bars to the first holes and third holes on the bottom of the keyboard shelf with 4-sheet screws. Then align the brackets on the mouse shelf to the holes on the support bars and attach using 8 sheet metal screws.

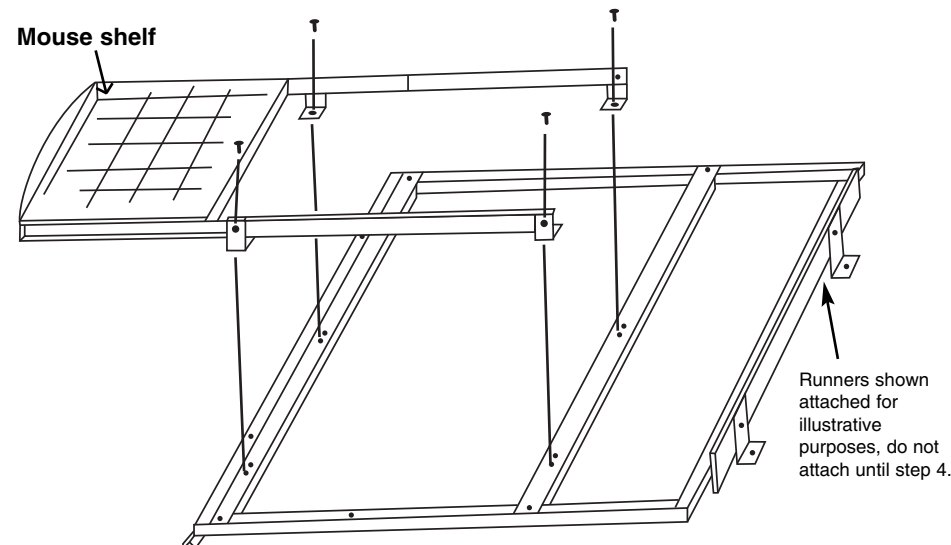

### Step 2

Mount the four L-Brackets to the holes on the top shelf using 4- bolts, 4- washers and 4- nuts. Be sure brackets are pointing outward. Then align the two threaded holes on the side of the runners to the hole on the brackets and attach with two pan head screws. Do the same to the other side.

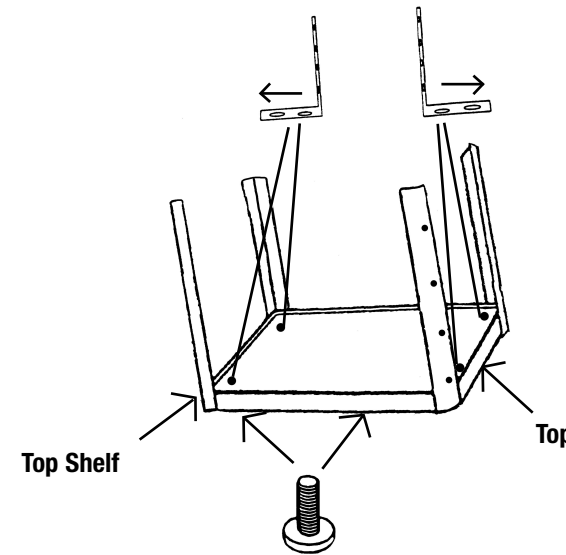

### Step 3

Repeat step 2 for second shelf.

### Step 4

Extend runners outward and align the holes on the side of the keyboard to the first hole and last hole on the slides, and attach with two sheet metal screws on each side. Repeat for second shelf.

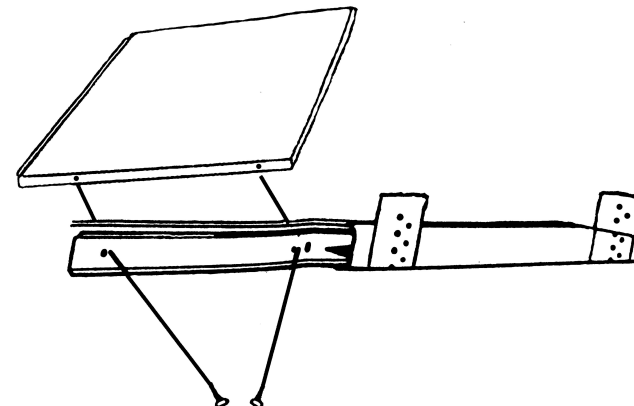

5. Turn bottom stand assembly upside down on a smooth surface. Push the four casters firmly into the caster socket holes in bottom of each leg as illustrated.

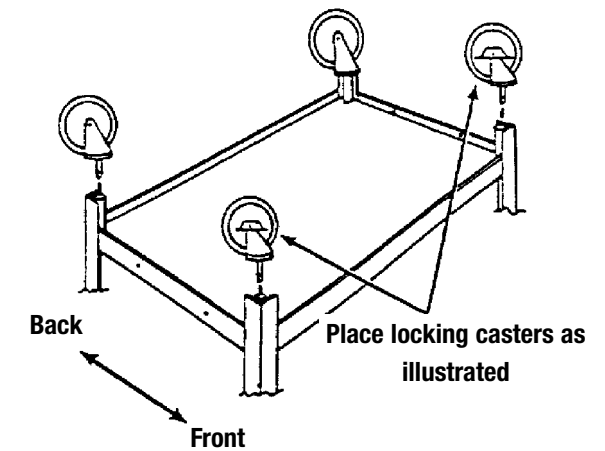

6. **a.** Attach second shelf to top stand assembly at desired height using 4 bolts and kep nuts. Position top stand assembly over bottom stand assembly, as illustrated.

Note: Be sure cabling hole in corner of top and middle shelves line up on top of each other.

- b.** Adjust top stand assembly up or down to desired height. Align holes in all four legs, insert bolts and fasten with four kep nuts, as illustrated. Place rubber mat on top shelf.

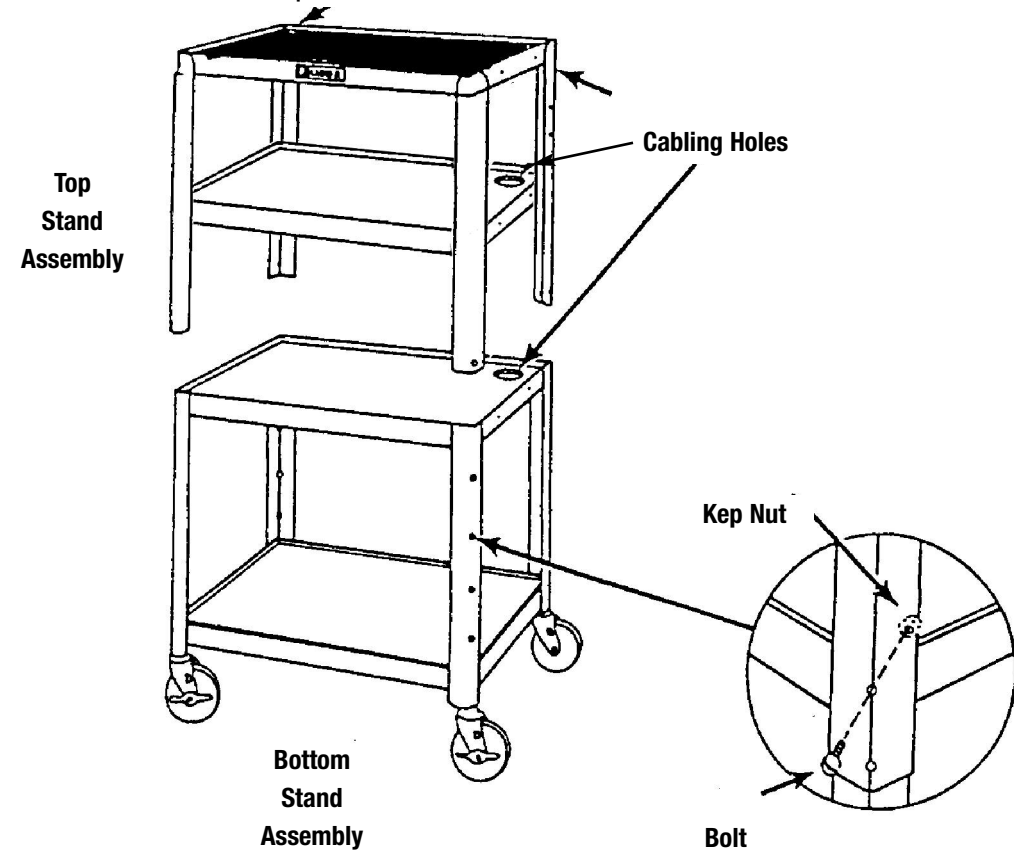

## 7. ELECTRIC ASSEMBLY

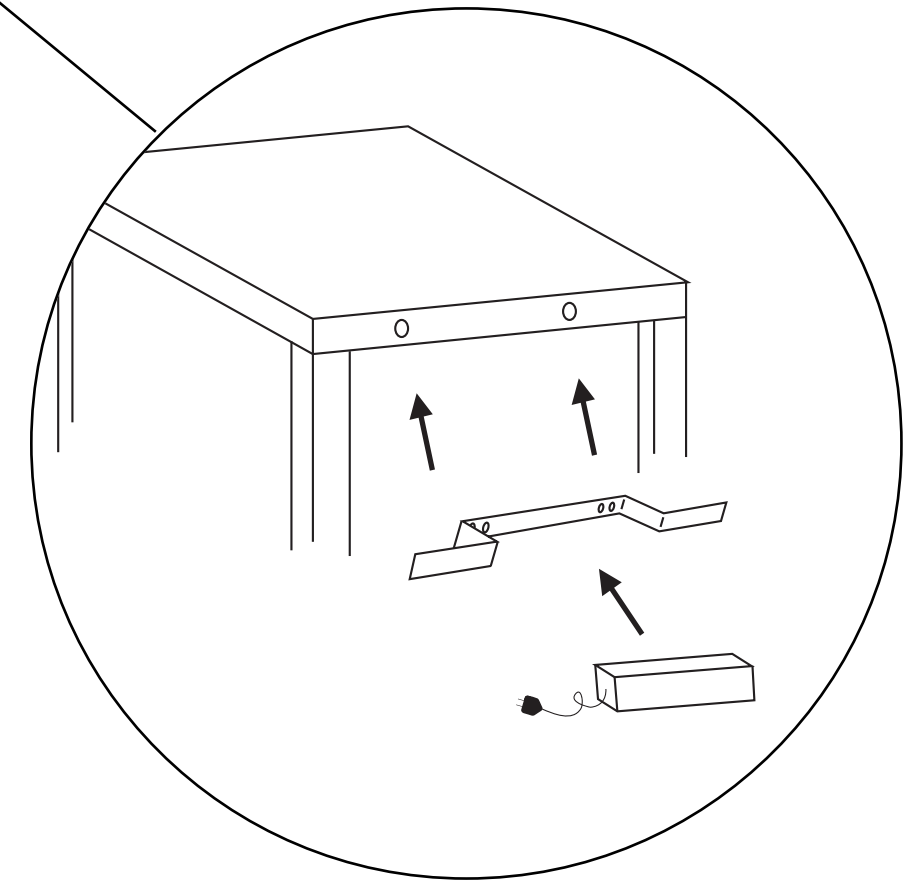
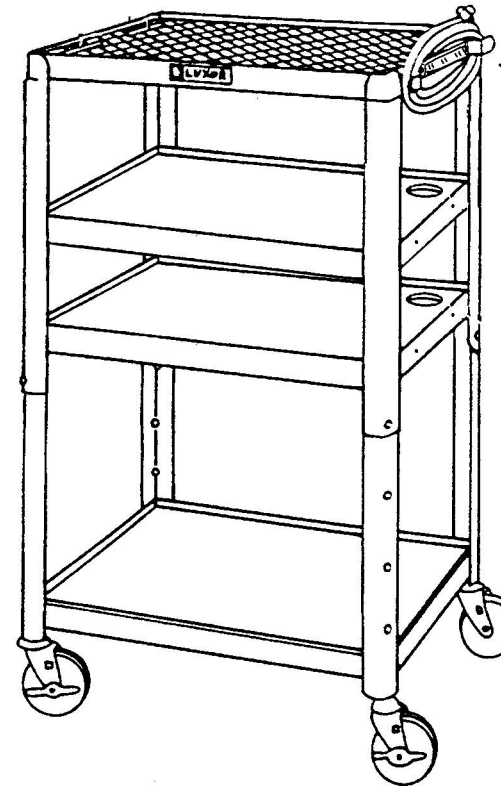

### PARTS LIST FOR STEPS 5, 6, AND 7.

- 1 - Set of casters
- 1 - Power cord
- 1 - Cord wrap
- 1 - Rubber mat

### FOR ATTACHING TOP AND MIDDLE SHELF TO BOTTOM HALF

- 8 - Kep nuts
- 8 - 3/4" bolts

Place metal cordwrap onto metal top shelf making sure that the holes on the cordwrap align with the holes on the shelf. Place the two screws through the holes of the electrical assembly. Place the electrical assembly with the two screws through the holes of the cordwrap and mounting bracket. Secure screws with wingnuts.