

Instruction Sheet - AVJDL



Customer Service Dept
2245 Delany Rd
Waukegan, IL 60087
Ph: 847/244-1800 • 800/323-4656
Fax: 847/244-1818 • 800/327-1698

SIDE SHELF ADD ON ASSEMBLY INSTRUCTIONS

Parts List per shelf

- 1 - shelf assembly
- 2 - keps nuts
- 2 - screws
- 3 - spacers

NOTE!!
ILLUSTRATION SHOWS MOUNTING TO TOP CART SHELF.
IF THE SIDE SHELF IS TO BE ATTACHED TO AN
INTERMEDIATE SHELF, ONE (1) SPACER/REINFORCEMENT
PLATE MUST BE ASSEMBLED BETWEEN THE FLIP SHELF
BRACKET AND THE CART SHELF.
THIS IS NECESSARY TO ACCOMADATE THE TWO
ANGLE LEG THICKNESS.

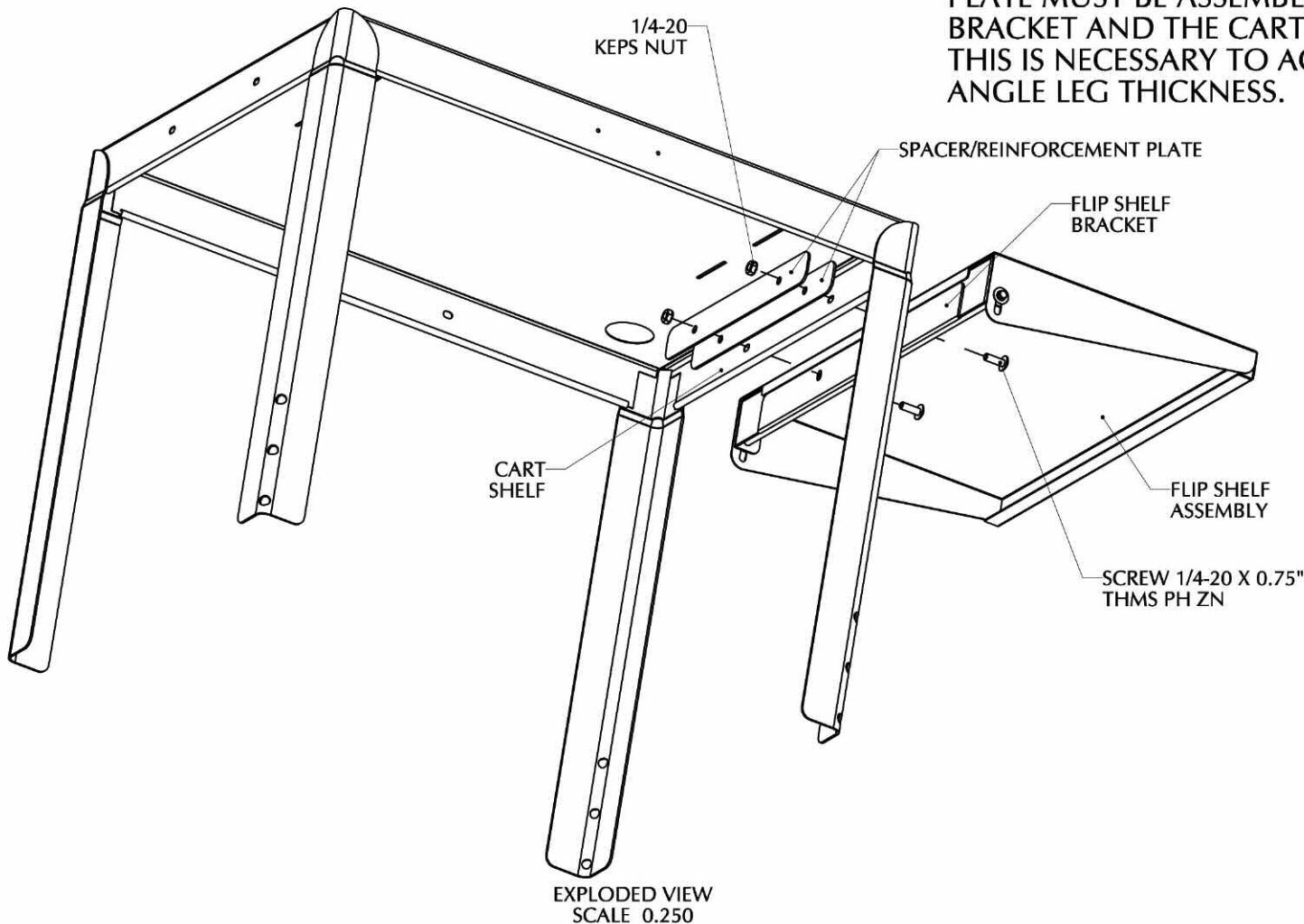

18JUL07