

# Instruction Sheet

## Model AVJOH48MM /AVJOH48MM-2

### Adjustable Height Multi-Media Workstation



Customer Service Dept  
2245 Delany Rd  
Waukegan, IL 60087  
Ph: 847/244-1800 • 800/323-4656  
Fax: 847/244-1818 • 800/327-1698



- 1 - Top Section
- 1 - Bottom Section
- 1 - Pull-out keyboard drawer with slides
- 1 - Middle Shelf

### Parts List

- 1 - Carton with 8" pneumatic wheels and mounting bolts/washers and Nuts
- 1 - Power Cord
- 1 - Cord Holder
- 1 - Cord Wrap

### Tools Required:

- Screwdriver
- Open end wrench or channel locks

**\*\*\* Important \*\*\***  
**Due to the size of this unit,**  
**two people are required to assemble this unit.**

### Assembly Instructions

1. Open carton and remove top section of table - set aside.
2. Remove platform from unit and flip over to assemble - see section B.
3. Remove bottom section from carton.
- \*4. Carefully remove middle shelf - set aside.
5. Turn over bottom section and begin mounting wheels - see section A.
- \*6. Set the middle shelf on top of the bottom shelf.
7. Note: Before setting the top section over the bottom section determine the desired height. Align hole, insert bolts and fasten with wing nuts.
8. Mount electric assembly as shown - see section C.
- \*9. Raise middle shelf to desired height. Align holes, insert bolts and fasten with wing nuts.
10. Unpack pull-out keyboard shelf.

**Note: Over head platform is attached flush to unit, and keyboard is already installed.**

**\*Steps 4,6, and 9 apply to AVJOH48MM-3 Shelf unit only.**

**Please discard packing materials only after you are completely satisfied.**

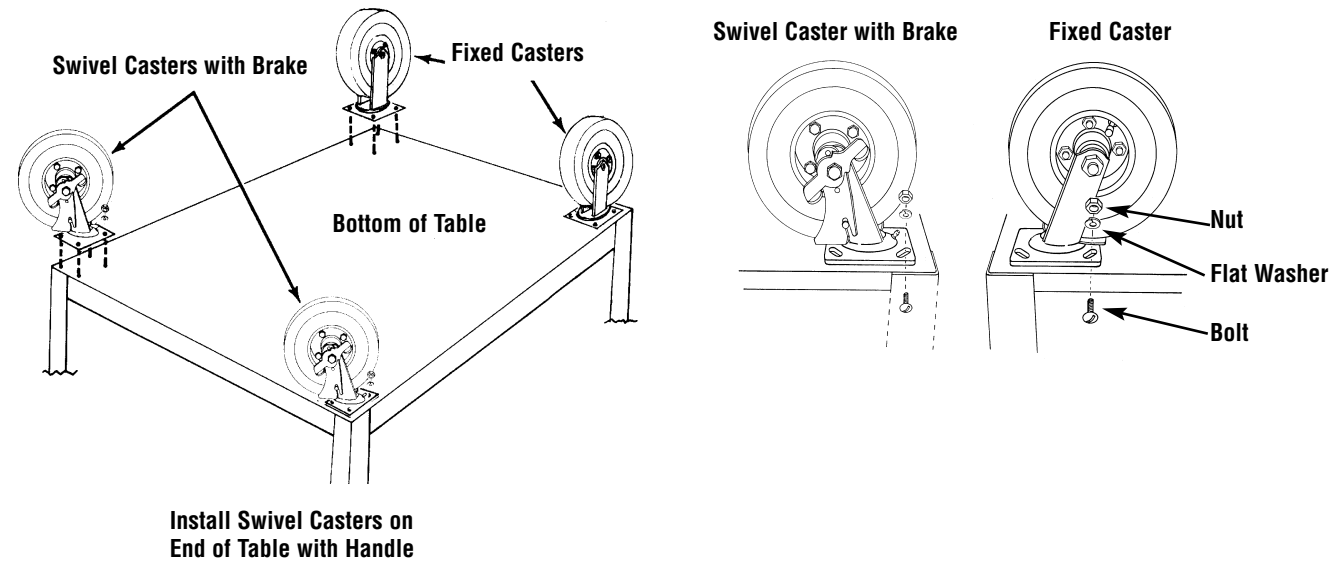

Turn your equipment table upside down. Install the two swivel casters on the end of the table with the handle using 8 bolts, flat washers and nuts.

The bolt head should be on the inside of bottom shelf and lock washer, and nut should go directly against the caster plate on the under side of table as illustrated.

Install the remaining two fixed casters in the same manner as the two swivel casters.

Turn your table upright, it is now ready for use. Use cord ties to secure equipment cords inside of table leg by threading them through the small holes located in the leg with the "U" bracket.

### A - Assembly for Pneumatic Wheels

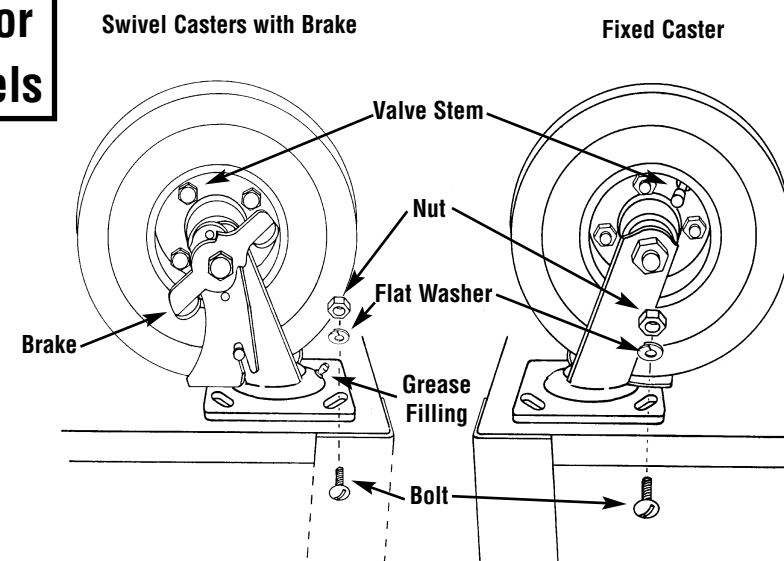

To assure proper operation of your equipment table:

1. Check tire pressure every 30 days. Pressure should be maintained at 50 lbs.
2. Grease fittings on swivel casters every 45 days using a standard grease gun, using regular multi-purpose grease. (Both available at your local hardware store.)

**CAUTION: Do not over grease. Using too much grease may cause seepage around the bearings and may cause grease to run down the wheel onto the floor.**

Replacement parts may be purchased from your Luxor dealer should you encounter a problem with your pneumatic casters.

Part No.	Description
80111	Inner tube only.
80109	8" pneumatic wheel w/o brake
80110	8" pneumatic wheel w/brake
80000	Tire only

## B - Assembly for Platform Shelf

**Note: Platform is packaged flush with top shelf for shipping purposes.**

1. Measure the height of your overhead projector - then choose the height of shelf and assemble according to diagram below.

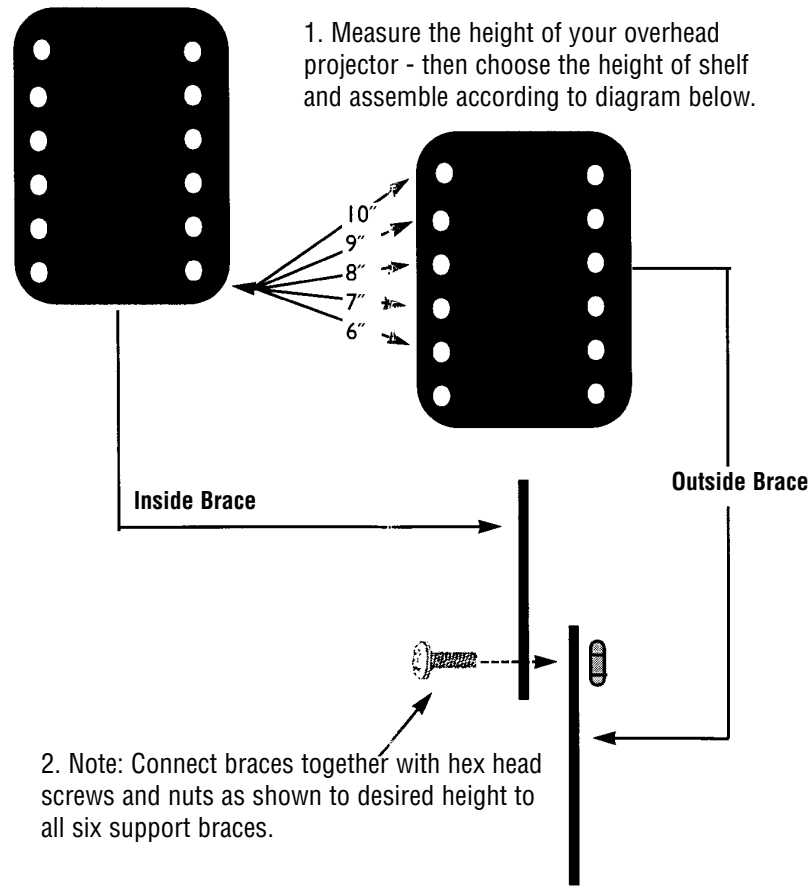

2. Note: Connect braces together with hex head screws and nuts as shown to desired height to all six support braces.

3. Attach platform to bottom holes of support braces with 8 - 1/2" bolts. Flip platform over before reattaching.

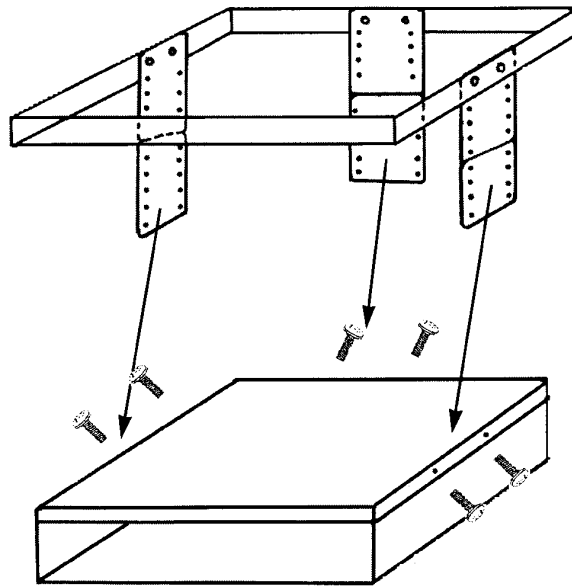

## C - Assembly for Electric

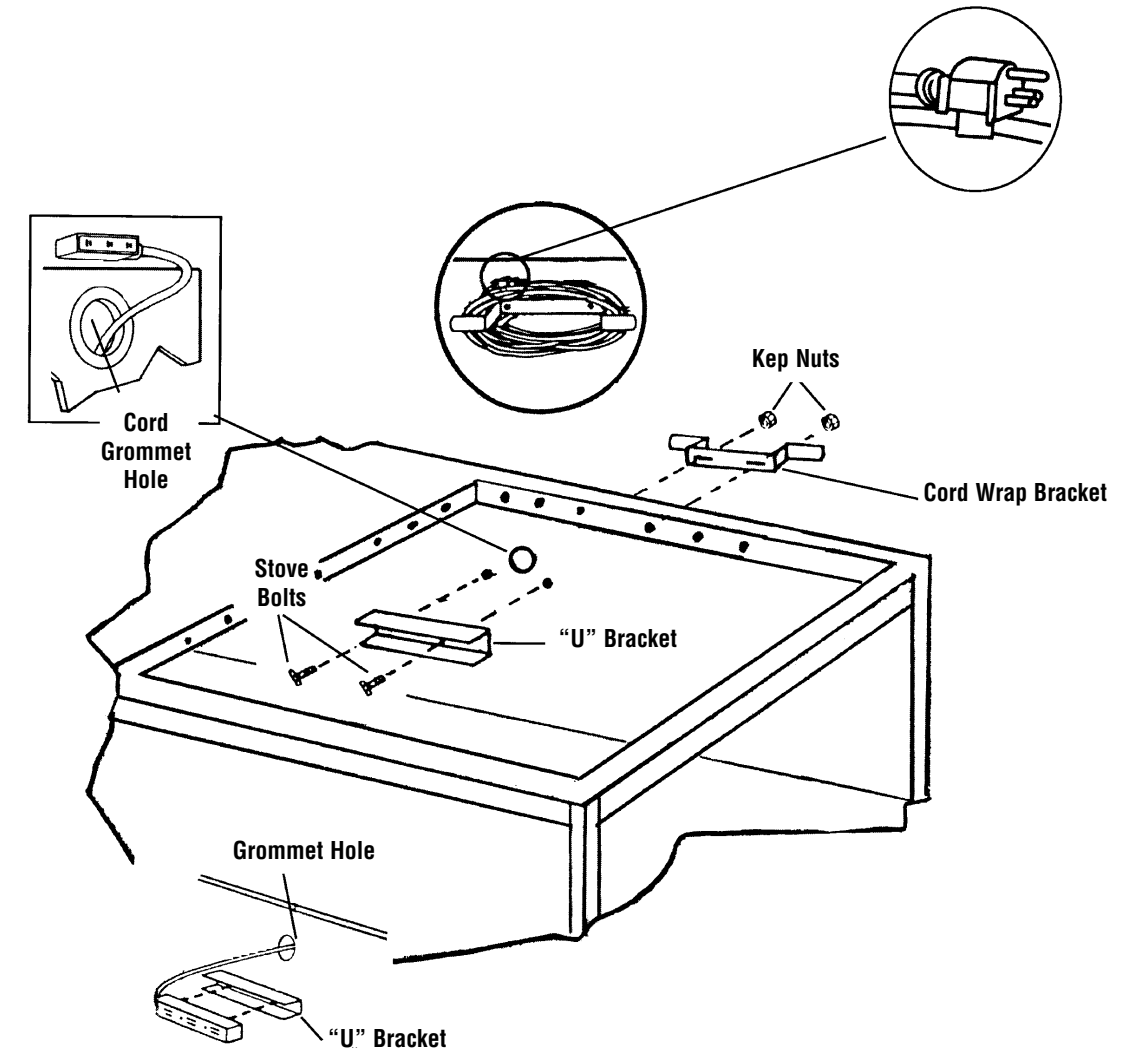

Press 3-outlet power cord into "U" bracket and feed remaining cord through grommet hole and wrap remaining cord around cord wrap bracket. For safety and neat appearance, secure plug to cord with plug snap.