

Instruction Sheet

Universal and B Model Big Wheel Assembly



Customer Service Dept
2245 Delany Rd
Waukegan, IL 60087
Ph: 847/244-1800 • 800/323-4656
Fax: 847/244-1818 • 800/327-1698



PARTS LIST

- 2 - 8" Big wheels
- 2 - Axle caps
- 1 - Axle
- 2 - Axle Brackets - Patented

Tools Required

Steel Hammer

***NOTE:** If the mobile table you purchased was a big wheel model, the axle provided will be an exact fit. However, the big wheel set is also provided as a universal table accessory to fit existing mobile equipment tables which are designed to accept push-in type 4" casters. Dimensions of mobile tables vary. **The axle provided is the maximum length necessary to accommodate this variance. Therefore, it may be necessary to shorten the length of the axle with a hacksaw and finish the edge of the axle with a file.**

1. Turn the table upside down. If 4" casters are already installed, these should be removed. The big wheel is to be installed along the most narrow side of the table. (See illus. #A.) Install axle brackets as illustrated.
2. Tap one axle cap onto one end of the axle and slide the big wheel onto the axle from the opposite end.
3. Install axle by sliding it through axle brackets so that big wheel is resting against side of bracket. (See illus. #A.)
4. Tap remaining axle cap onto axle end. (See illus #B.) The big wheels should be a snug fit with little side-to-side play. If fitting is too tight, the axle is too short; if too loose, the axle is too long. A proper fit is an important safety consideration. Contact your Luxor dealer if you require further assistance. You may fax Luxor toll free.

IMPORTANT:

The following instructions apply to the big wheel kit when purchased as a big wheel accessory. **The axle should protrude only 1/4" beyond the wheel. If it is longer, mark the axle at 1/4" and cut off the remaining end with a hacksaw. Taper the cut off end with a file to more easily affix the remaining axle cap.**

5. Two 4" casters should be installed now. These should be locking casters.

Your Universal Big Wheel Assembly is now ready for use. It will make your table safer and more stable. Additional safety accessories are available. Write "Safer Tables," Luxor Corporation, 2245 Delany Road, Waukegan, IL 60087.

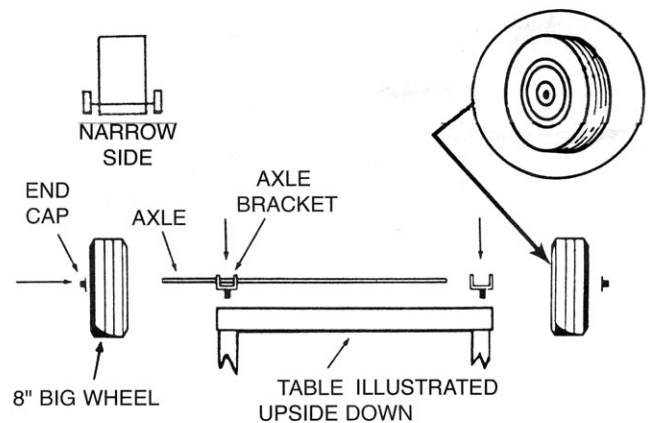

ILLUSTRATION #A

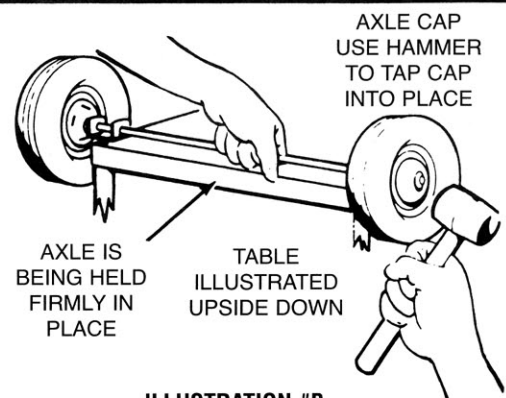

ILLUSTRATION #B



LUXOR