

INSTRUCTION SHEET

Endura Model CHLEMFP



Customer Service Dept.
2245 Delany Road
Waukegan, IL 60087
Ph: 847/244-1800 • 800/323-4656
Fax: 847/244-1818 • 800/327-1698

PARTS LIST

CHLEMPs

- 1 - Top shelf w/handle
- 1 - Middle shelf
- 1 - Bottom shelf
- 4 - 20" Legs
- 4 - 12" Legs
- 2 - Pull out shelves
- 4 - Runners
- 4 - Shelf runner adapters
- 2 - Casters
- 2 - Casters w/brake
- 12 - Small 1/2" screws
- 1 - "L" bracket
- 2 - Sheet metal screws

- 1 - Surge protected power cord
- 1 - Cord Wrap
- 8 - Allen Head Set Screws
- 1 - Allen Wrench
- 1 - Grommet pass through
- 4 - Sure grip pads
- 1 - Safety label

TOOLS REQUIRED:

- 1 - Rubber mallet (included)
- 1 - Slotted screwdriver
- 1 - Phillips screwdriver

1

IMPORTANT

The electrical unit should be assembled first. If your Endura Workstation was supplied with the Electrical Assembly and Cable-Track™ Cord Management System, see reverse side of this sheet for assembly instructions.

If your Endura Workstation **does not have** the Electrical Assembly and Cable-Track™ Cord Management System, start by closing the electrical plug housing in the handle of the top shelf as illustrated.

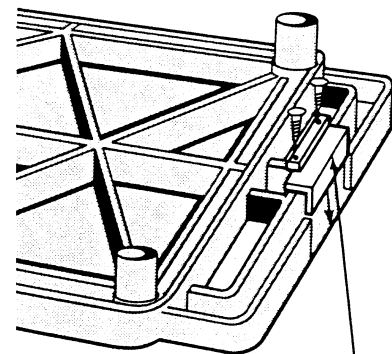

PLUG HOUSING COVER

2

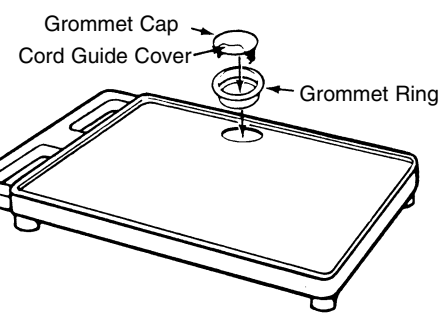

INSTALL GROMMET CAP

Install grommet ring by tapping into place with rubber mallet. Snap off cord guide cover from grommet cap so equipment plug may be run through grommet to plug unit, then insert grommet cap into grommet ring.

FIGURE 1

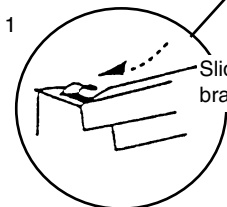

Slide end of shelf bracket under tab.

FIGURE 2

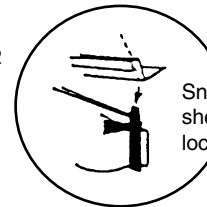

Snap other end of shelf bracket over locking tongue.

3

SHELF RUNNER ADAPTER

Allen head set screw & wrench

Set shelf height as desired then tighten Allen head set screws to secure.

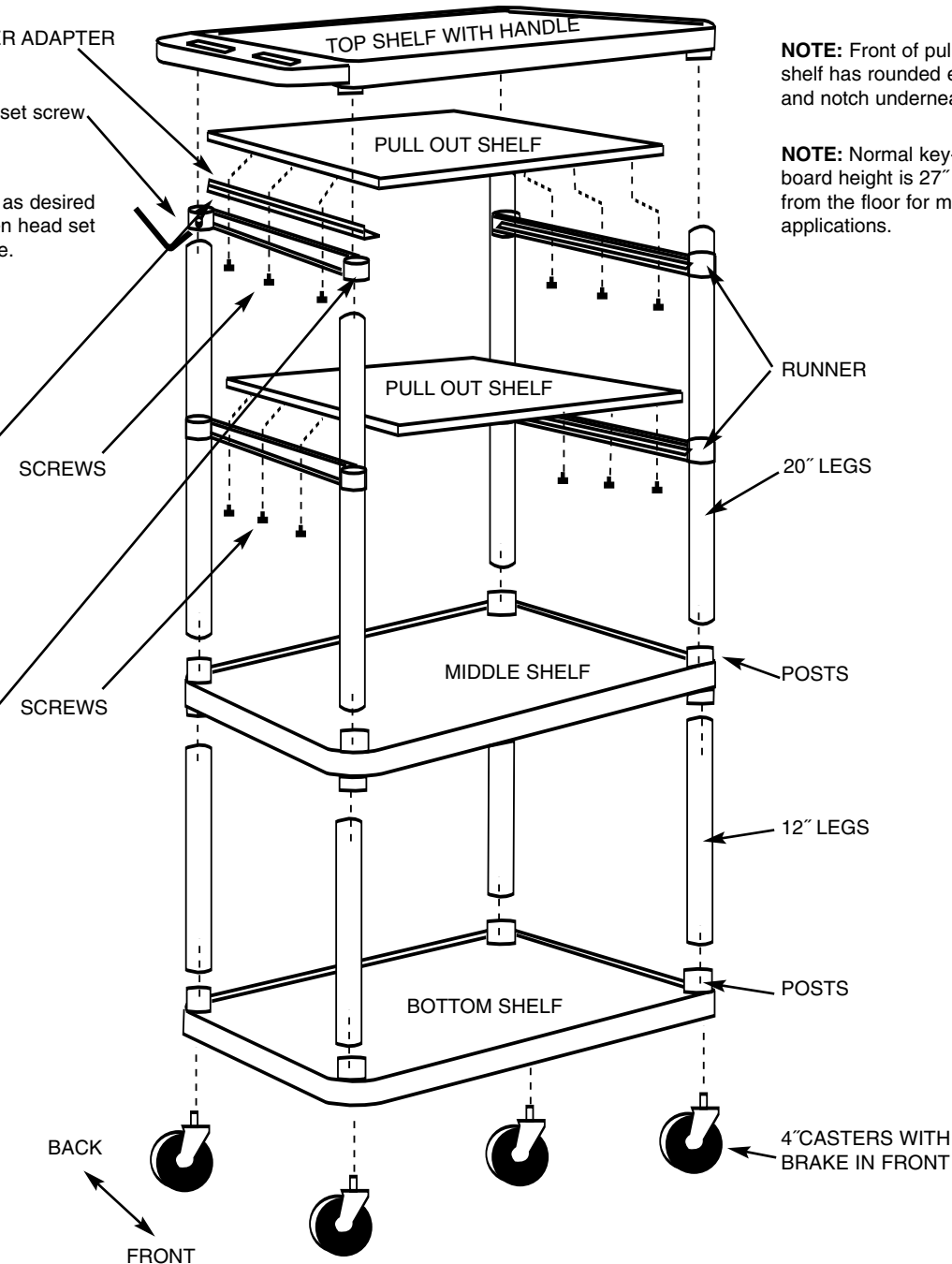

NOTE: Front of pull out shelf has rounded edge and notch underneath.

NOTE: Normal keyboard height is 27" from the floor for most applications.

ASSEMBLY

1. Separate and identify all parts. Electrical unit must be installed first. Follow instructions at far left.
2. Lay bottom shelf on a smooth surface, posts facing up. Take 12" legs and tap onto posts until fully seated. Place middle shelf over 12" legs and tap each corner until fully seated. Place 20" legs over posts on middle shelf, tap until fully seated.
3. Slide left and right runners over 20" legs. Tab is rear of runner and black rubber locking tongue is front. (See Figure 1) Do not attempt to secure runners at this time.
4. Take top shelf and align posts over legs and tap each corner until fully seated. **Note:** Grommet hole in shelf must face the rear of cart. Remember tabs on runners are the rear of cart.
5. Turn cart upside down and tap casters into caster sockets. Casters with brake must be installed on front of cart. Turn cart right side up.
6. Thread allen set screws into runners, see diagram. Measure 27" from the ground up and, using allen wrench, tighten set screws until runners are secured.
7. Take shelf runner adapter brackets and secure to pull out shelf using six 1/2" sheet metal screws. **Note:** Adapter brackets have a hole on one end, this is the front of the bracket. That hole must be on the side of the shelf with the rounded edge.
8. Next, take shelf and slip rear of adapter bracket under tab on runner (See Figure 2). Front of adapter bracket has hole that goes over black rubber locking tongue. Push down until it "snaps" into place. Cart is now ready to use.

Instructions - Electrical Assembly

Cable-Track™ Management System and Cord Wrap

Your Endura mobile equipment table incorporates the Cable-Track™ Cord Management System. This exclusive feature manages electrical cord, keeping them safely out of the way. This system includes a 3-outlet, 15 foot surge suppressing electric assembly (UL and CSA listed) which is built into the safety handle. Please review these instructions carefully to maximize the added safety provided by Luxor's Cable-Track™ Cord Management System.

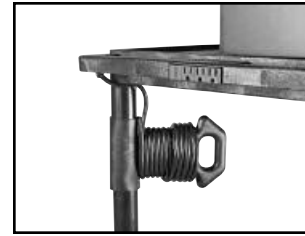

PARTS LIST

- | | |
|--------------------------------|------------------------------|
| 1 - Surge protected power cord | 1 - Power cord retainer clip |
| 1 - Cord wrap | 2 - "E" Clips |
| 4 - Cord management ties | |
| 4 - Sheet metal screws | |

ILLUSTRATION A

1. The electric unit should be assembled first. Cord wrap must be installed on leg before assembly of complete unit. See below.

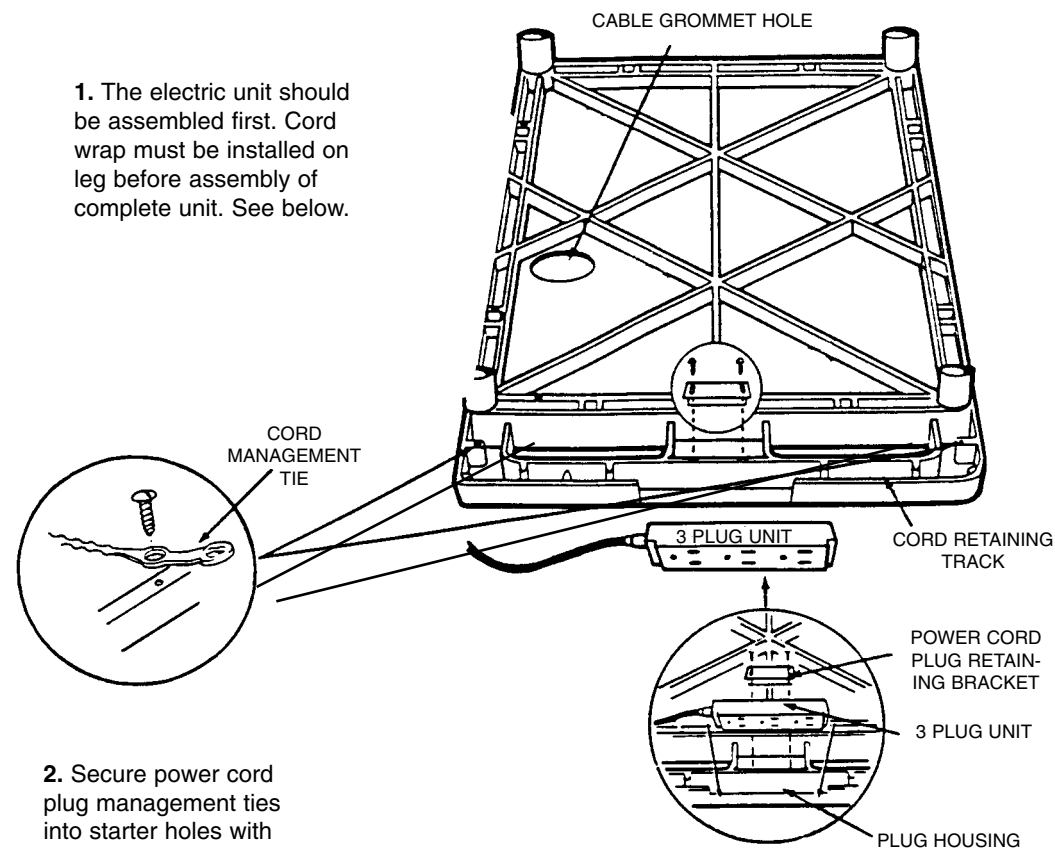

2. Secure power cord plug management ties into starter holes with sheet metal screws.

3. Firmly seat electric assembly 3 plug unit into handle plug housing as illustrated. Secure with power cord plug retaining bracket.

ILLUSTRATION B

Install correct size leg on top shelf then slide cord wrap down over leg into position.

4. Thread power cord through cord retaining track, secure with cord management ties by wrapping tie around cord and fastening. Cut off any unnecessary extra length of tie. Wrap remaining cord around the cord wrap bracket. For safety and neat appearance, secure cord plug to cord by utilizing plug snap.

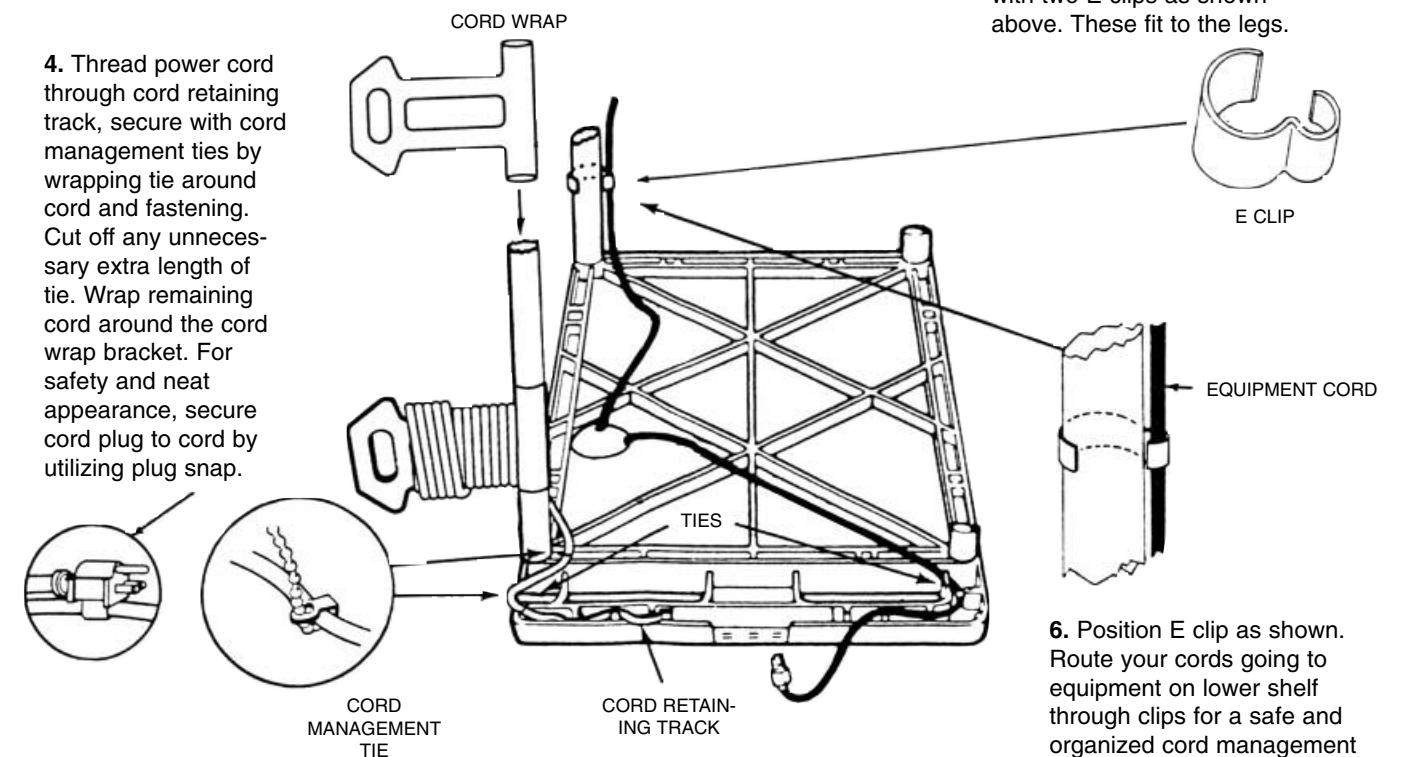

5. Each unit comes complete with two E clips as shown above. These fit to the legs.

6. Position E clip as shown. Route your cords going to equipment on lower shelf through clips for a safe and organized cord management system.