

Instruction Sheet LCT29 Computer Workstation



Customer Service Dept
2245 Delany Rd
Waukegan, IL 60087

Ph: 847/244-1800 • 800/323-4656
Fax: 847/244-1818 • 800/327-1698



PARTS LIST

- | | |
|--------------------|--------------------|
| 2 - Side frames | 1 - Bottom shelf |
| 1 - Set of runners | 1 - Keyboard shelf |
| 1 - Worksurface | 1 - Mouse shelf |
| 1 - Set casters | 1 - Hardware pack |
| 1 - Support brace | |

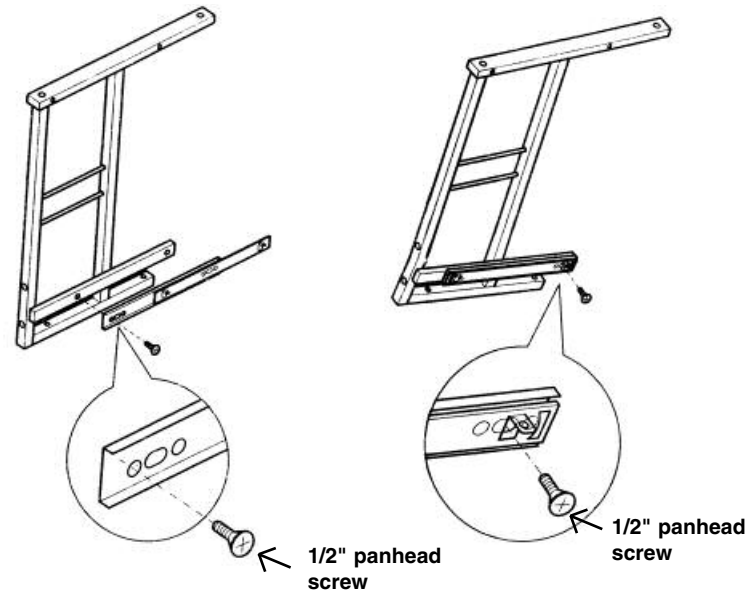
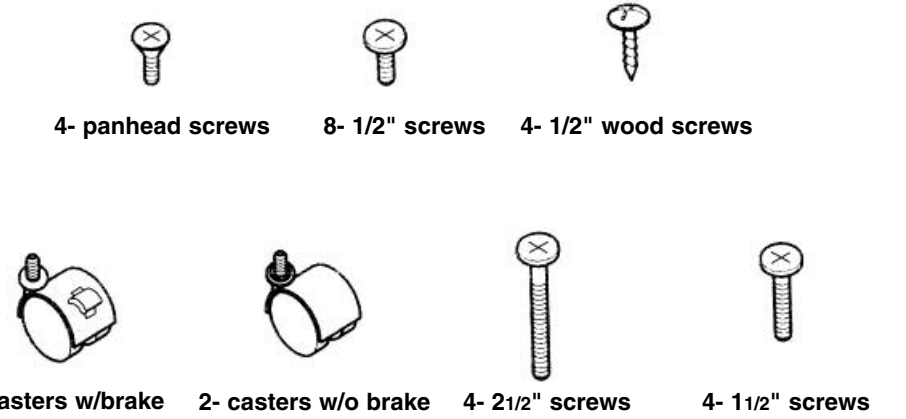

Step 1
Attach runners as shown in diagrams using 4-1/2" panhead screws.

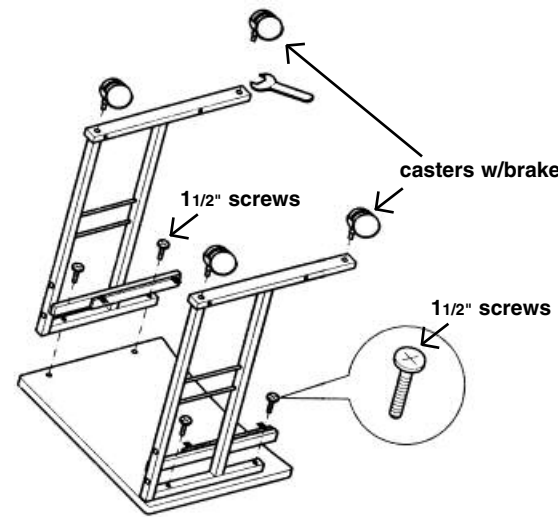

Step 2
Turn work surface over so the threaded holes are exposed. Align the side frame holes to the holes on the work surface and attach using 4-11/2" screws. Then attach casters placing the casters with brake to the front part of the side frames.

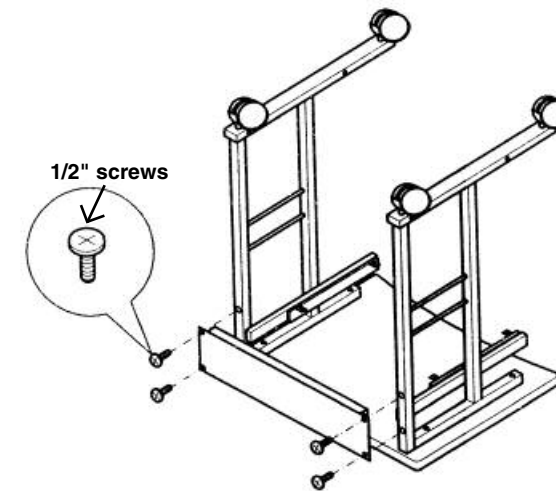

Step 3
Attach back support with 4-1/2" screws.

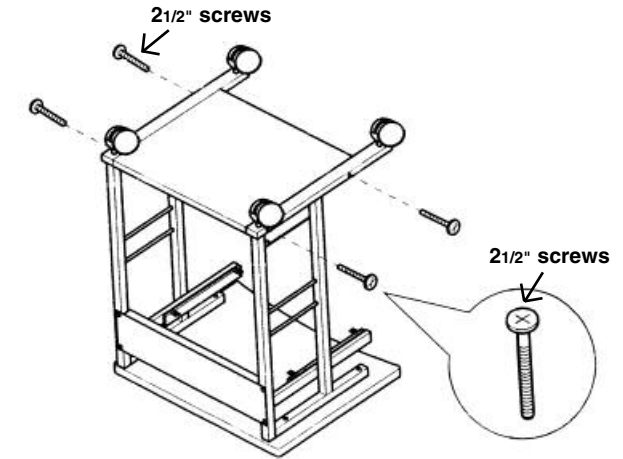

Step 4
Place bottom shelf between the bottom of the side frames and attach using the 4-2 1/2" screws.

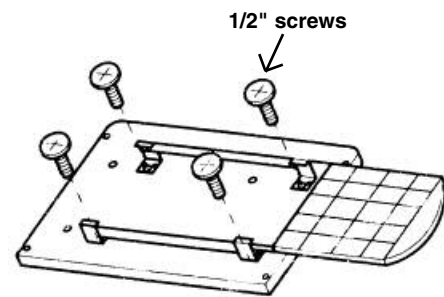

Step 5
Turn keyboard over and attach the mouse shelf with 4-1/2" screws. (NOTE: Mouse shelf can pull-out on left or right side.)

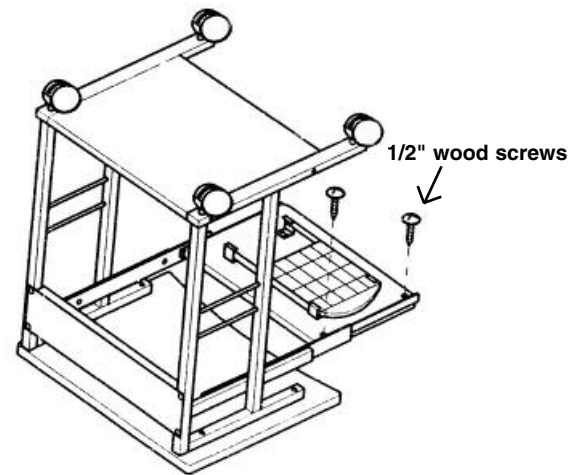

Step 6
Align the four predrilled holes on the bottom of the keyboard corners and attach with the 4-1/2" wood screws.

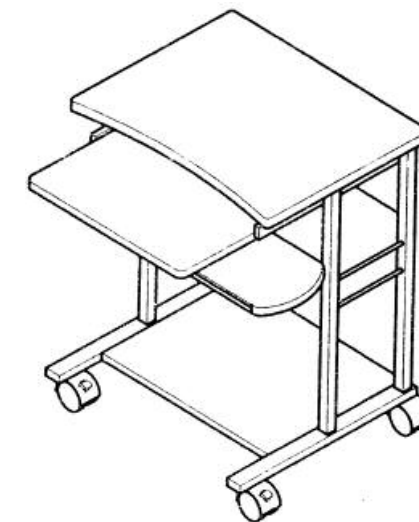

Step 7
Turn table onto casters and it's now ready for use.