

Instruction Sheet Fixed Height Steel Computer Workstation Model LCT2

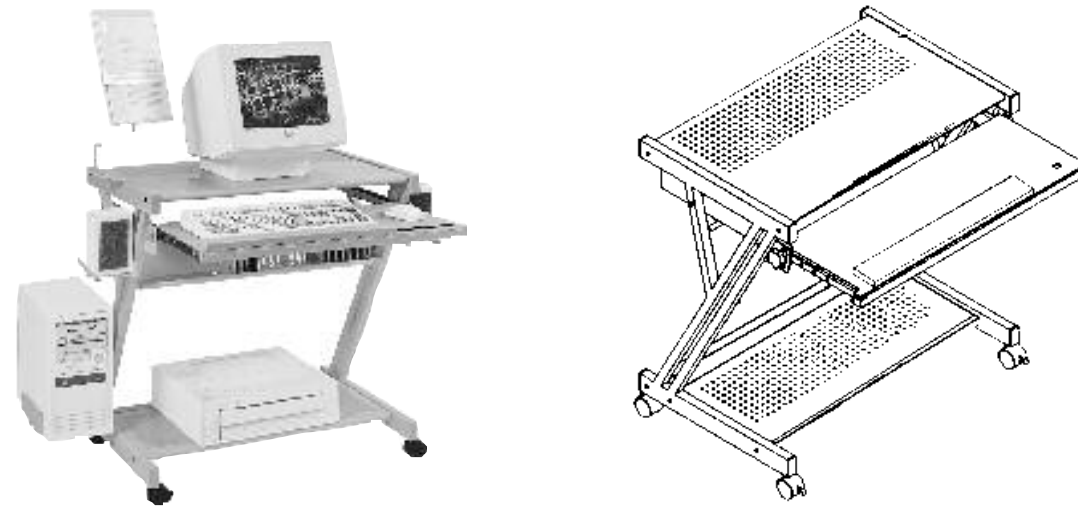

Customer Service Dept.
2245 Delany Rd.
Waukegan, IL 60087
Ph: 847/244-1800 • 800/323-4656
Fax: 847-244-1818 • 800/327-1698



Instructions for Assembly

We suggest you unpack all components from the container before assembling the table. Separate the parts using the parts list on back side as a guide. Report any shortages immediately.

1

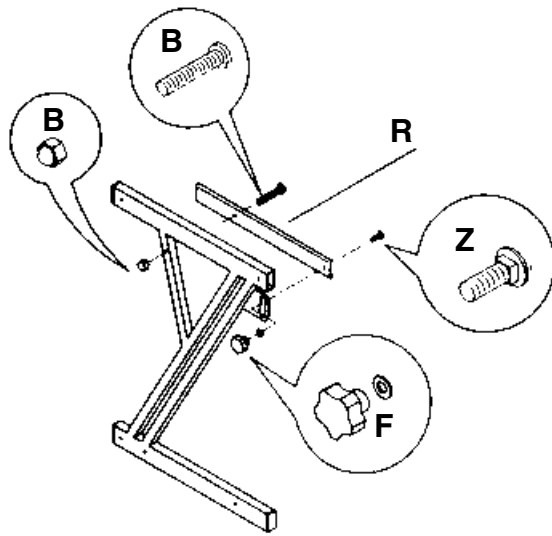

Step 1 & 2

Assemble left and right side frames per diagrams #1 and #2.

- A. Insert **bolt B** through **runner R** and **side frame O**. Fasten all components together with **cap nut B**.
- B. Insert top **end caps A** into tops of side frames.
- C. Insert **caster sockets C** into side panels. Align threads with hole in bottom of frame.
- D. Insert **caster D and E** as shown in diagram #2.

2

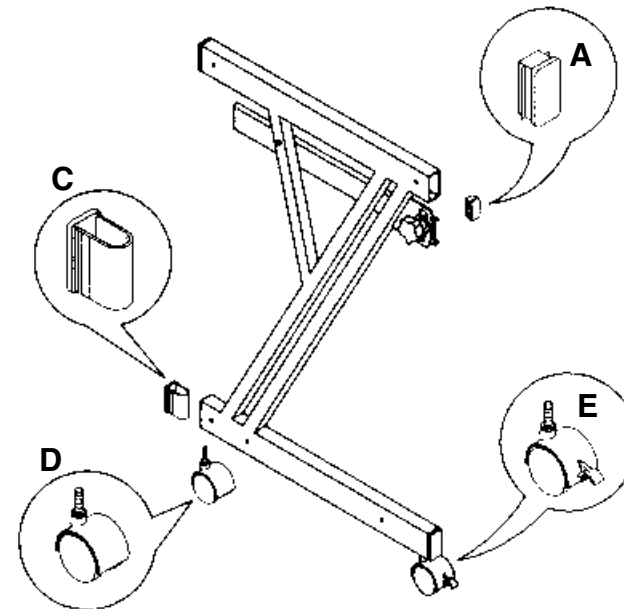

3

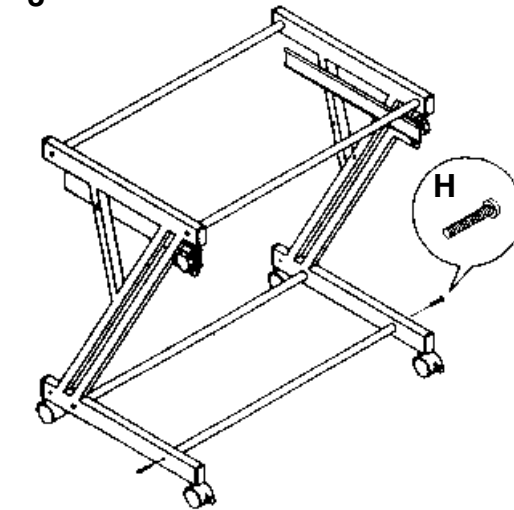

Step 3

- Connect left and right side frames as shown in diagram #3.
- A. Fasten 4 **cross bars P** with **bolt H**. Hand tighten only.

4

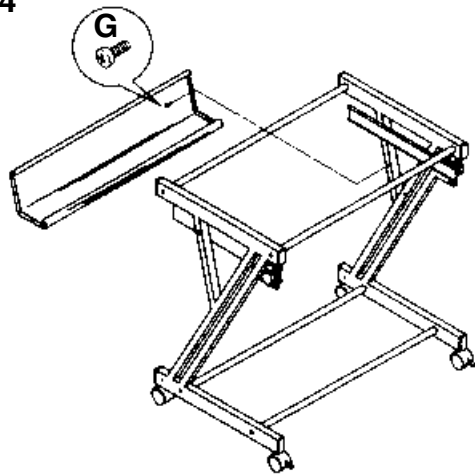

Step 4

- Assemble CD rack per diagram #4.
- A. Align **CD rack Q** with holes on inside of frames with **bolt G**.

5

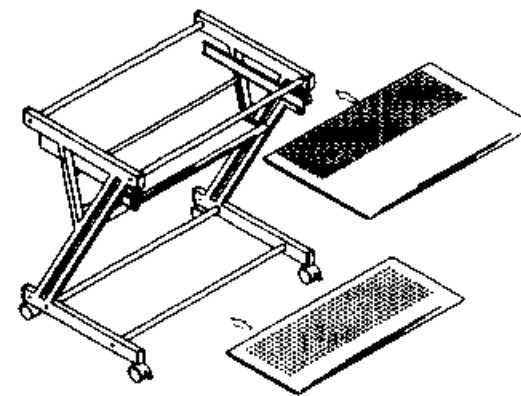

Step 5

- Position top monitor shelf and bottom CPU shelf over **cross bars Q** per diagram #5.

6

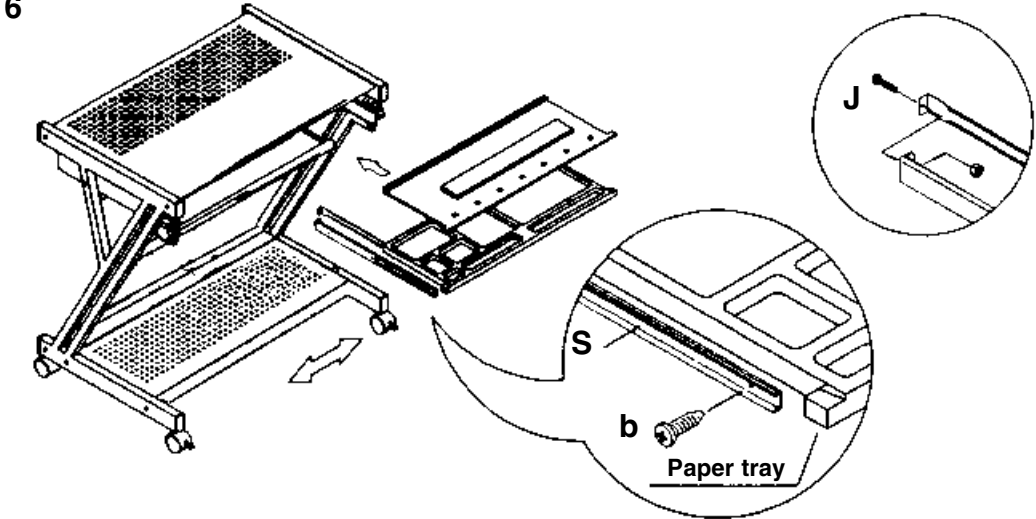

Step 6

- Assemble keyboard shelf per diagram #6

PARTS LIST

