

# Instruction Sheet Model LCW180



Customer Service Dept  
2245 Delany Rd  
Waukegan, IL 60087  
Ph: 847/244-1800 • 800/323-4656  
Fax: 847/244-1818 • 800/327-1698



ID	A1 φ 4X12	A2 φ 6X16	A3 φ 5X10	B	C φ 8	E	F	G1	G2	W	W2
PARTS											
QTY	11	48	4	4	8	4	8	2	2	2	2

ID	H	J	L	K	M1	M2	O	O1	N	P	Q	R	S	Z
PARTS														
QTY	2	4	4	2	2	1	1	1	1	1	1	1	2	2

## Step 1 Center Cabinet

assemble **O1** bottom front plate to **M1** left side panel and **M1** right side panel and also **O** bottom rear panel.

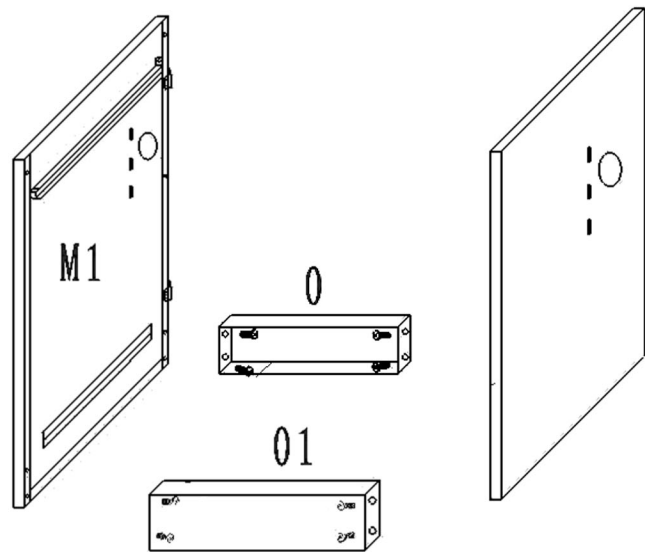

## Step 3 Center Cabinet

Turn right side up and add middle or center **M2** panel with 3 screws into the bottom base **P**.

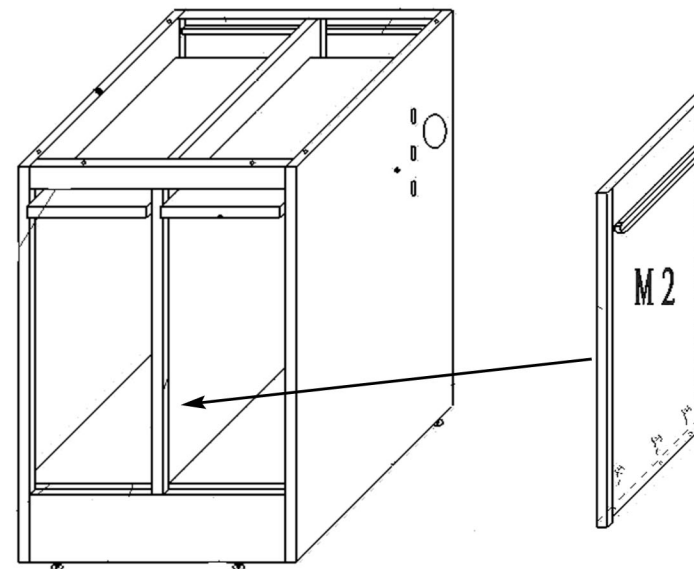

## Step 5 Legs

screw glides **C** into **G2** bottom feet, screw through **G2** bottom feet into **L** & **J** leg posts Place **G1** on top screwing down to **J** & **L** for both legs.

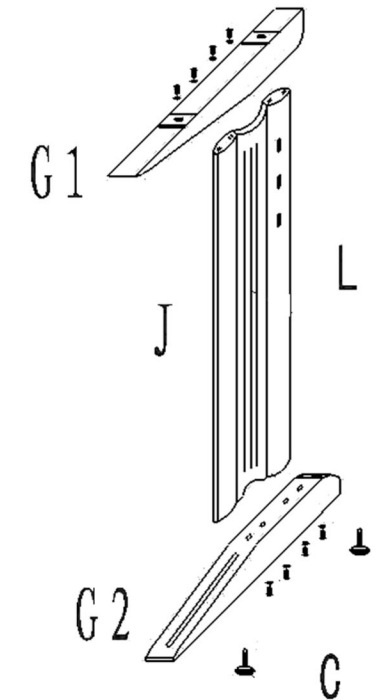

## Step 2 Center Cabinet

Turn upside down and insert bottom base panel **P** attaching with 4 screws.

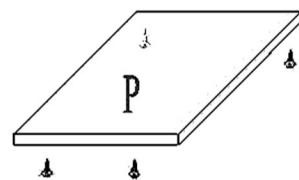

## Step 4 Center Cabinet

Add **N** front top with 2 screws into **M1** panels left and right and **Q** top rear with 2 screws also into **M1** panels left and right.

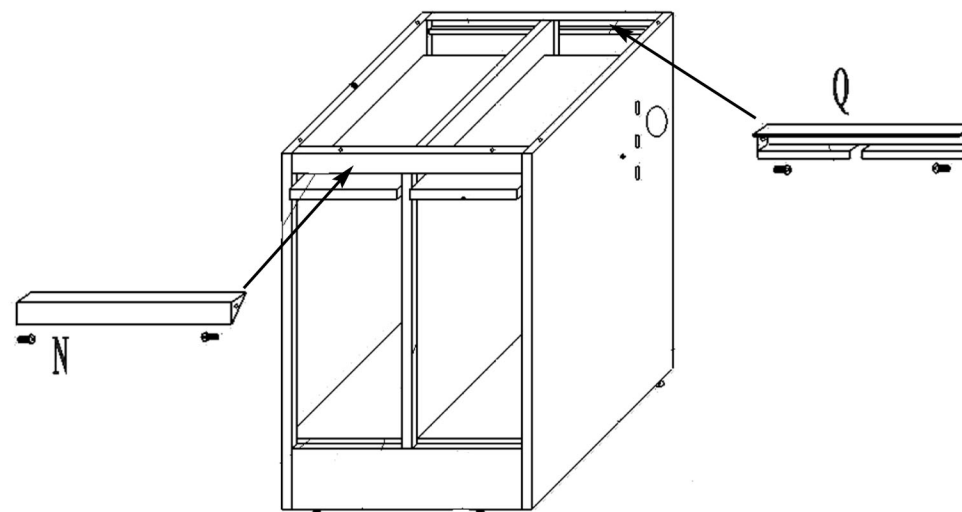

## Step 6 Keyboards

Assemble runners **E** to sides of keyboards **H**  
Attach brackets **G** to runners **H**, when attached the brackets will point away from the keyboard.

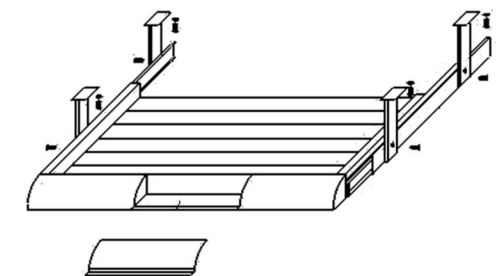

**Step 7** **Combine Assemblies**

Note: do not over tighten as this may cause stripping of the bolts and void the warranty.

Lay top **R** upside down with onto a non-scratching surface.

Turn cabinet assembly upside down again onto **R** with front brackets **N** toward beveled edge over the mounting holes in the top's underside. Insert **K** tabs into rear sides of M1 on each side. Insert the opposite tabs of **K** into **L** on each side. Mount **G1** into **R** and repeat on other side.

Tighten cabinet to **R** with 6 screws. Screw glides **C** into the base at each corner. Mount Keyboard assembly to top **R** on each side with the rounded front facing the beveled edge.

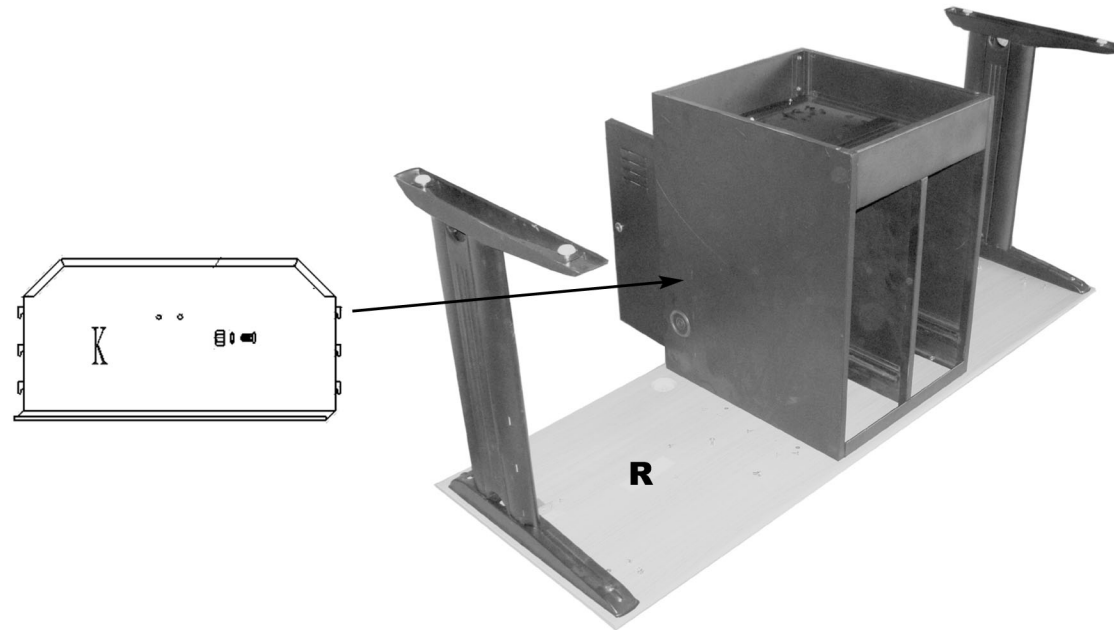

**Step 8** **Install Doors**

Install wheels for the front doors **W**.

Place wheels **B** into tracks inside the cabinet.

Retract spring axel **D** and when level release the axel into the wheel **B** for each side of the door. Then repeat on the other side.

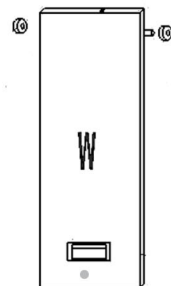

**Step 9** **Combine Assemblies**

With assistance upright the entire unit;

Position **W2** hinges over the pins to install the rear doors.

At the front insert **Z** into **W**.

