

Instruction Sheet - Endura Mobile Tables

Endura Model LE-26 & LE-27 Two Shelf Mobile Table

Endura Model LE-34, LE-40, LE-42, LE-48 & LE-54 Three Shelf Mobile Tables

Congratulations for having chosen an excellent Luxor product.

Your purchase is backed by Luxor's satisfaction guarantee. Luxor is a service oriented company. As a service to you, we are enclosing a "satisfaction guarantee" request card. Should a problem arise needing our assistance simply fill out the card and fax it to us toll free or mail postage paid to Luxor. Be sure to include your telephone number. Upon receipt of your

service request, we will give it immediate attention to be sure that you will be completely satisfied with your purchase.

Thank you for your confidence.

Customer Service Dept.
LUXOR
2245 Delany Road
Waukegan, IL 60087

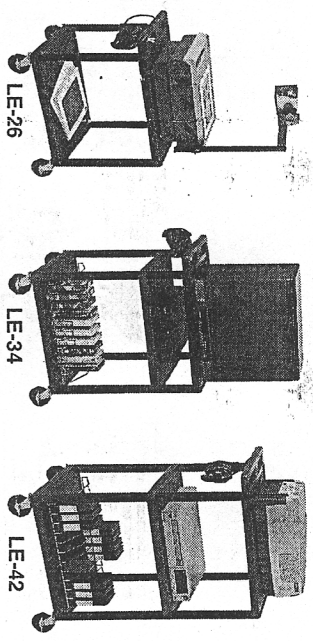

Parts List

- | | |
|----------------------------------|---|
| Models LE-26& LE-27 | Models LE-34, LE-40, LE-42, LE-48 & LE-54 |
| 1- Bottom shelf w/caster sockets | 1- Bottom shelf w/caster sockets |
| 1- Top shelf w/handle | 1- Top shelf w/handle |
| 4- Long legs | 1- Center shelf w/light leg post |
| 4- Casters (2 with brakes) | 4- Short legs |
| 1- Grommet pass-through | 4- Long legs |
| | 4- Casters (2 with brakes) |
| | 1- Grommet pass-through |
- Tools Required:
1- Rubber mallet (supplied)
1- Slotted screwdriver

WARRANTY

THE LUXOR LIFETIME WARRANTY

Luxor Endura Tables are fully warranted when used for their intended purpose. Use for other purposes, wherein weight loads, become excessive, will negate the warranty and may create a safety hazard.

IMPORTANT:

The electrical unit should be assembled first.

If your Endura Table was supplied with the Electrical Assembly and Cable-Track™ Cord Management System, see reverse side of this sheet for assembly instructions.

If your Endura Table does not have the Electrical Assembly and Cable-Track™ Cord Management System, start by closing the electrical plug housing in the handle of the top shelf.

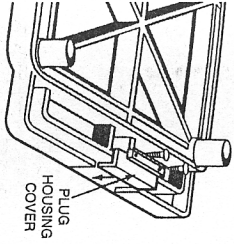

MODELS LE-26 & LE-27

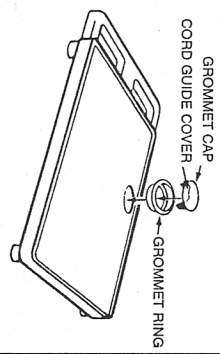

1. Install grommet ring by tapping into place with rubber mallet. Insert grommet cap as illustrated. For tables with electric assembly, snap off cord guide cover from grommet cap so equipment plug may be run through grommet to plug unit. Then insert grommet cap into grommet ring.

MODELS LE-34, LE-40, LE-42, LE-48 & LE-54

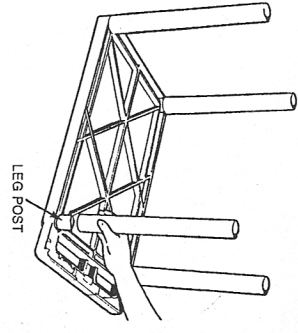

2. Lay top shelf (with handle) ribbed side up on a smooth surface. Push all 4 legs onto leg posts.

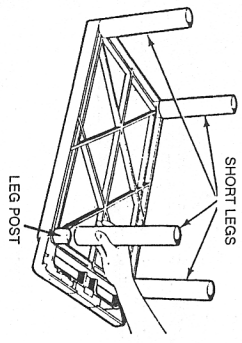

1. Install grommet ring and cap as illustrated in Step #1 above. Lay top shelf (with handle) ribbed side up on a smooth surface. Push all 4 short legs onto leg posts.

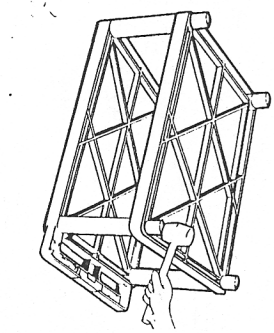

2. Position center shelf (with 8 leg posts) ribbed side up over the 4 legs and insert leg posts into short legs. Using a rubber mallet, firmly hammer center shelf into legs until all four legs are seated (flush) against the surfaces of both shelves.

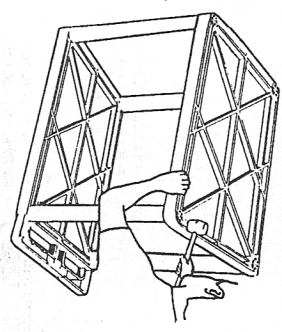

3. Position bottom shelf, ribbed side up, over the 4 legs and insert leg posts into legs. Using a rubber mallet, firmly hammer bottom shelf into legs until all four legs are seated (flush) against the surfaces of both shelves.

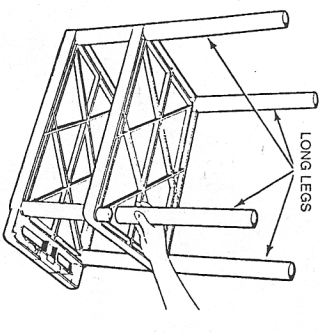

3. Push remaining 4 long legs into leg posts of center shelf.

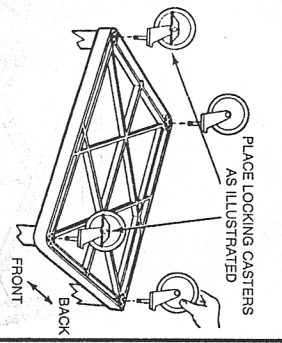

4. Push the four casters firmly into the holes in each corner of the bottom shelf. Important: Casters must be fully seated. Tap firmly with rubber mallet to properly seat casters. Turn your Endura Table right side up.

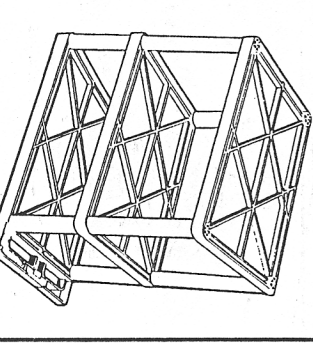

4. Position bottom shelf, ribbed side up, over the 4 long legs and insert leg posts into long legs. Firmly hammer bottom shelf until seated onto all 4 legs.

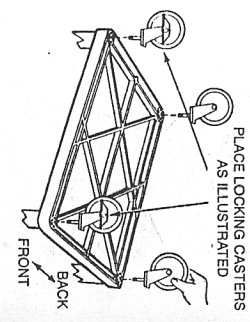

5. Push the four casters firmly into the holes in each corner of the bottom shelf. Important: Casters must be fully seated. Tap firmly with rubber mallet to properly seat casters. Turn your Endura Table right side up.