

Instruction Sheet - Endura Mobile Tables

Endura Model LE26 & LE27 Two Shelf Mobile Table

Endura Model LE34, LE40, LE42, LE48 & LE54 Three Shelf Mobile Tables



Customer Service Dept
2245 Delany Rd
Waukegan, IL 60087
Ph: 847/244-1800 • 800/323-4656
Fax: 847/244-1818 • 800/327-1698



LE26



LE34



LE42

Parts List

Models LE-26& LE-27

- 1- Bottom shelf w/caster sockets
- 1- Top shelf w/handle
- 4- Long legs
- 4- Casters (2 with brakes)
- 1- Grommet pass-through

Tools Required:

- 1- Rubber mallet (supplied)
- 1- Slotted screwdriver

Models LE-34, LE-40, LE-42, LE-48 & LE-54

- 1- Bottom shelf w/caster sockets
- 1- Top shelf w/handle
- 1- Center shelf w/weight leg posts
- 4- Short legs
- 4- Long legs
- 4- Casters (2 with brakes)
- 1- Grommet pass-through

IMPORTANT:

The electrical unit should be assembled first.

If your Endura Table was supplied with the Electrical Assembly and Cable-Track™ Cord Management System, see reverse side of this sheet for assembly instructions.

If your Endura Table **does not have** the Electrical Assembly and Cable-Track™ Cord Management System, start by closing the electrical plug housing in the handle of the top shelf.

MODELS LE26 & LE27

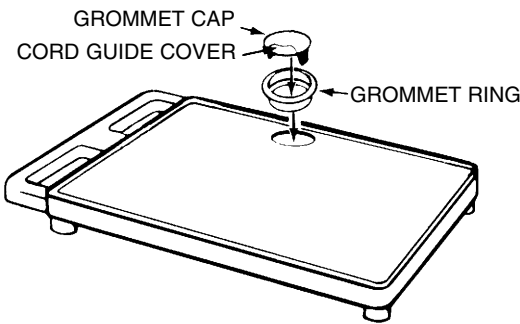

1. Install grommet ring by tapping into place with rubber mallet. Insert grommet cap as illustrated. For tables with electric assembly, snap off cord guide cover from grommet cap so equipment plug may be run through grommet to plug unit. Then insert grommet cap into grommet ring.

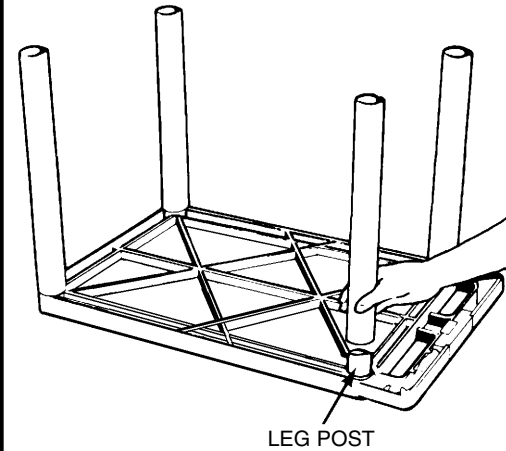

2. Lay top shelf (with handle) ribbed side up on a smooth surface. Push all 4 legs onto leg posts.

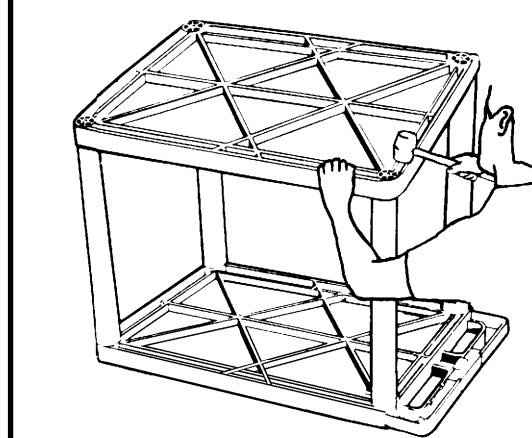

3. Position bottom shelf, ribbed side up, over the 4 legs and insert leg posts into legs. Using a rubber mallet, firmly hammer bottom shelf into legs until all four legs are seated (flush) against the surfaces of both shelves.

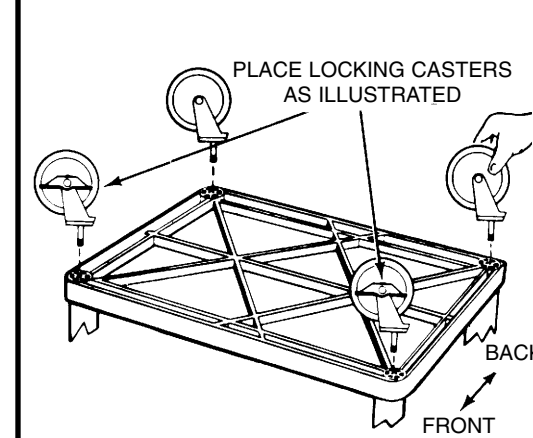

4. Push the four casters firmly into the holes in each corner of the bottom shelf. **Important:** Casters must be fully seated. Tap firmly with rubber mallet to properly seat casters. Turn your Endura Table right side up.

WARRANTY

THE LUXOR LIFETIME WARRANTY

Luxor Endura Tables are fully warranted when used for their intended purpose. Use for other purposes, wherein weight loads become excessive, will negate the warranty and may create a safety hazard.

MODELS LE34, LE40, LE42, LE48 & LE54

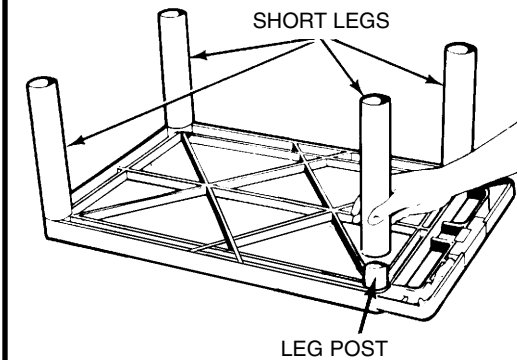
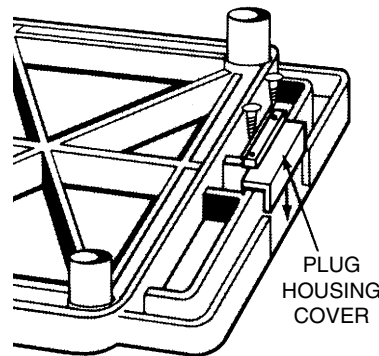

1. Install grommet ring and cap as illustrated in Step #1 above. Lay top shelf (with handle) ribbed side up on a smooth surface. Push all 4 **short legs** onto leg posts.

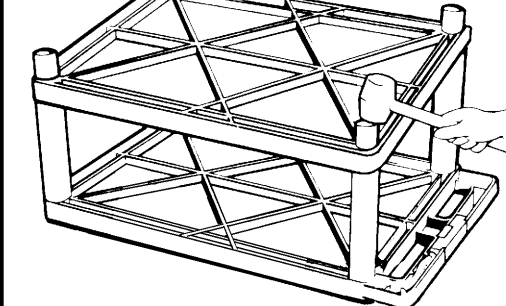

2. Position **center shelf** (with 8 leg posts) ribbed side up over the 4 legs and insert leg posts into **short legs**. Using a rubber mallet, firmly hammer center shelf into legs until all four legs are seated (flush) against the surfaces of both shelves.

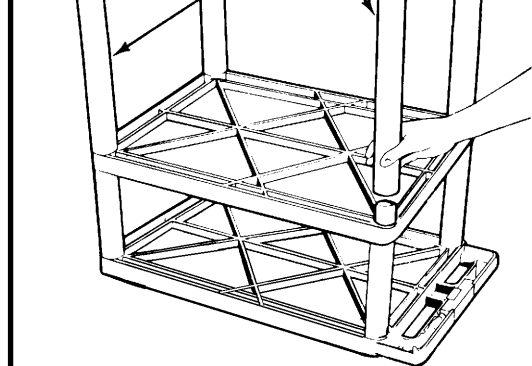

3. Push remaining 4 **long legs** into leg posts of center shelf.

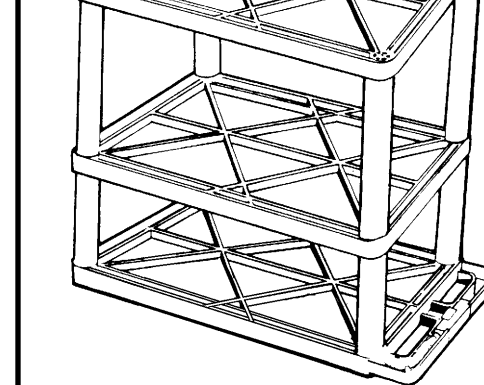

4. Position bottom shelf, ribbed side up, over the 4 **long legs** and insert leg posts into long legs. Firmly hammer bottom shelf until seated onto all 4 legs.

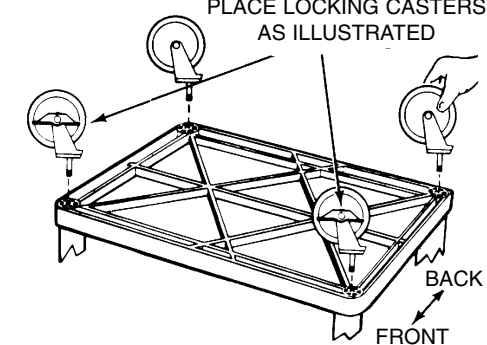

5. Push the four casters firmly into the holes in each corner of the bottom shelf. **Important:** Casters must be fully seated. Tap firmly with rubber mallet to properly seat casters. Turn your Endura Table right side up.

Instructions For - Electrical Assembly and Cable-Track™ Management System

Your Endura mobile equipment table incorporates the Cable-Track™ cord management system. This exclusive feature manages electrical cords, keeping them safely out of the way. This system includes a 3-outlet, 15 foot surge suppressing electric assembly (U.L. and C.S.A.

listed) which is built into the safety handle. Please review these instructions carefully to maximize the added safety provided by Luxor's Cable-Track™ cord management system.

Parts List	
1 - Surge protected power cord	1 - Power cord retainer clip
2 - "E"-clips	
4 - Cord management ties	4 - Sheet metal screws

ILLUSTRATION A

Important

1. The electrical unit should be assembled first.

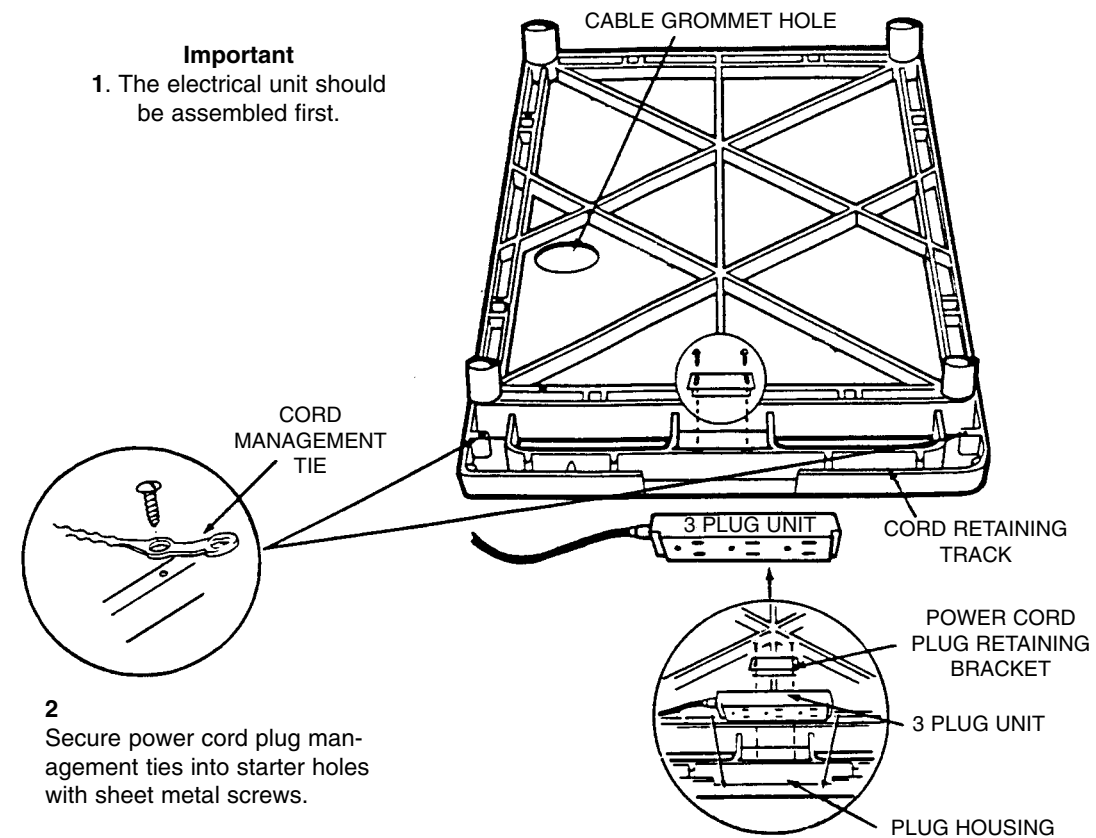

2. Secure power cord plug management ties into starter holes with sheet metal screws.

3. Firmly seat electric assembly 3 plug unit into handle plug housing as illustrated. Secure with power cord plug retaining bracket.