



INSTALLATION MANUAL



UNIVERSAL FLAT PANEL DISPLAY CART

Model: LE40WTUD

LUXOR FURNITURE

2245 Delany Rd.
Waukegan, IL 60087
Phone: 847-244-1800 • 800-323-4656
Fax: 847-244-1818 • 800-327-1698

Congratulations on the purchase of your new Luxor Furniture LE40WTUD Flat Panel Display Cart. The LE40WTUD is a totally integrated mount/cart solution for 32" – 50" flat panel displays. To truly appreciate the capabilities and versatility of the LE40WTUD Flat Panel Display Cart, please read this installation manual completely.



Table of Contents

Warning Statements	- 2 -
Luxor Cart Parts List	- 3 -
Luxor Cart Installation Tools	- 4 -
LE40WTUD Shelf Cart Assembly Instructions.....	- 5 -
Electrical Assembly and Cable-Track Management System.....	- 6 -
Base Mount Assembly and Installation	- 7 -
Final Assembly	- 9 -
TTS Stand Parts List.....	- 10 -
TTS Stand Installation Tools	- 10 -
TTS Stand Assembly	- 14 -
Back Cover Plate Installation.....	- 16 -

Warning Statements

WARNING: LUXOR FURNITURE DOES NOT WARRANT AGAINST DAMAGE CAUSED BY THE USE OF ANY LUXOR FURNITURE PRODUCT FOR PURPOSES OTHER THAN THOSE FOR WHICH IT WAS DESIGNED OR DAMAGE CAUSED BY UNAUTHORIZED ATTACHMENTS OR MODIFICATIONS, AND IS NOT RESPONSIBLE FOR ANY DAMAGES, CLAIMS, DEMANDS, SUITS, ACTIONS OR CAUSES OF ACTION OF WHATEVER KIND RESULTING FROM, ARISING OUT OF OR IN ANY MANNER RELATING TO ANY SUCH USE, ATTACHMENTS OR MODIFICATIONS.

WARNING: THE FLOOR SHOULD BE CAPABLE OF SUPPORTING A MINIMUM WEIGHT OF 160 LBS. IF NOT, THE FLOOR MUST BE REINFORCED. THE WEIGHT OF THE FLAT PANEL SHOULD BE NO MORE THAN 160 LBS. PROPER INSTALLATION PROCEDURES BY QUALIFIED PERSONNEL AS OUTLINED IN THE INSTALLATIONS INSTRUCTIONS MUST BE ADHERED TO. FAILURE TO DO SO COULD RESULT IN SERIOUS PERSONAL INJURY.

WARNING: SAFETY MEASURES MUST BE PRACTICED AT ALL TIMES DURING THE INSTALLATION OF THIS PRODUCT. USE PROPER SAFETY GEAR AND TOOLS FOR THE INSTALLATION PROCEDURE TO PREVENT PERSONAL INJURY.

WARNING: PRIOR TO THE INSTALLATION OF THIS PRODUCT, THE INSTALLATION INSTRUCTIONS SHOULD BE READ AND COMPLETELY UNDERSTOOD. THE INSTALLATION INSTRUCTIONS MUST BE READ TO PREVENT PERSONAL INJURY AND PROPERTY DAMAGE. KEEP THESE INSTALLATION INSTRUCTIONS IN AN EASILY ACCESSIBLE LOCATION FOR FUTURE REFERENCE.



Indicates that the power plug is to be disconnected from the power outlet.
Safety precautions must be taken at all times.



Contact Luxor Furniture with any questions –
Customer Service – 847-244-1800



Warning and Caution statements.



Do not install on a structure that is prone to vibration, movement or chance of impact. Failure to do so could result in damage to the display and/or damage to the mounting surface.



Do not install near heater, fireplace, direct sunlight, air conditioning or any other source of direct heat energy. Failure to do so may result in damage to the display and could increase the risk of fire.











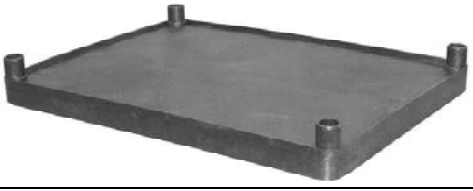





A qualified person should perform the installation procedure. Injury and/or damage can result from dropping or mishandling the projector

Luxor Cart Parts List

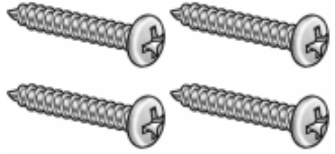
NOTE: Please familiarize yourself with all components contained herein.

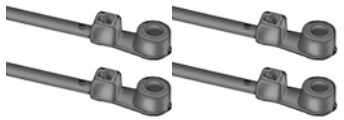
NOTE: Please review all WARNING and CAUTION statements (see Page 2) before beginning the installation of the LE40WTUD Flat Panel Display Cart.

<p>Bottom Shelf (Qty 1)</p> 	<p>Short Legs (Qty 4)</p> 
<p>Center Shelf (Qty 1)</p> 	<p>Long Legs (Qty 4)</p> 
<p>Top Shelf w/Handle (Qty 1)</p> 	<p>Casters (Qty 4 - 2 locking, 2 non-locking)</p> 
<p>Power Cord Storage Arm (Qty 1)</p> 	<p>Grommet Pass- Through (Qty 1)</p> 
<p>Rubber Mallet (Qty 1)</p> 	<p>Power Cord (Qty 1)</p> 
<p>Sheet Metal Screws (Qty 4)</p> 	<p>Power Cord Retainer Clip (Qty 1)</p> 
<p>"E" Clips (Qty 2)</p> 	<p>Cord Management Ties (Qty 4)</p> 
<p>Aluminum Base (Qty 1)</p> 	<p>Sandwich Plate (Qty 1)</p> 

Parts List (Cont.)

M5 x 20mm Phillips Head Screws (Qty 6)

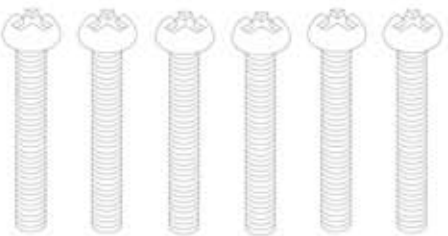

M5 Flat Washer (Qty 6)



M5 Lock Washer (Qty 6)



Luxor Cart Installation Tools

Soft Material/ Blanket
Allen Wrench

Phillips Head Screwdriver

Cabinet Pack Installation Instructions

18" LEG

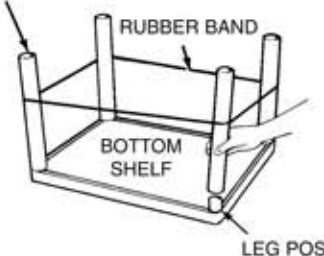

RUBBER BAND

BOTTOM SHELF

LEG POST

2
With bottom shelf facing up push all four 18" legs onto leg posts. Using rubber mallet hammer legs firmly into position. Legs must be seated (flush) against the shelf surface. Place rubber band around legs to aid in the assembly of cabinet side panels and doors.

TOP VIEW

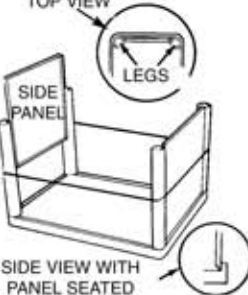

SIDE PANEL

LEGS

SIDE VIEW WITH PANEL SEATED INSIDE SHELF LIP

3
Install the side panels first. Slide panels down between legs until they are nested inside the shelf lip and flush against the shelf surface. Rubber band will hold legs and side panels in place while installing back panel and front door.



4
Install the back panel in the same manner as shown in Step #3. NOTE: Cabling hole in back panel should be toward the top.

NOTE: Models LE-40C, LE-48C, and LE-54C have double doors.



5
Install door panel same as back panel, with door handle at top.



CENTER SHELF

6
Begin seating of center shelf by holding door panel, leg and side panel as illustrated. Gently tap corner post into leg. Repeat on all 4 sides until all posts are partially inserted into legs. Now repeat hammering action more firmly going around to each shelf post and driving the leg posts more securely into the legs.
Top of panels and door frame must be nested into the underside of the center shelf lip in the same manner as the bottom shelf.



CORD GUIDE COVER

GROMMET CAP

GROMMET RING

TOP SHELF

CENTER SHELF

7
Push remaining 4 legs onto center shelf posts as illustrated. Place top shelf (with handle) onto legs. Insert leg posts into legs of top shelf. Using rubber mallet, firmly hammer top shelf into legs until all four legs are seated against shelf surface. Install grommet ring and grommet cap into top of shelf. For tables with electric assembly, snap off cord guide cover form grommet cap to allow equipment plug to be run through grommet. Insert grommet cap into grommet ring. Remove rubber band.

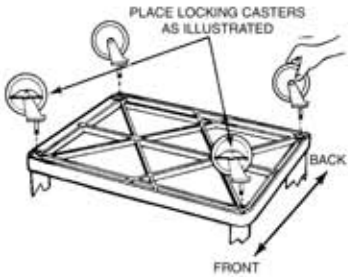

PLACE LOCKING CASTERS AS ILLUSTRATED

BACK

FRONT

8
Push the four casters firmly into the holes in each corner of the bottom shelf. Important: casters must be fully seated. Tap firmly with rubber mallet to properly seat casters. Turn your Endura Table right side up.

LE40WTUD Shelf Cart Assembly Instructions

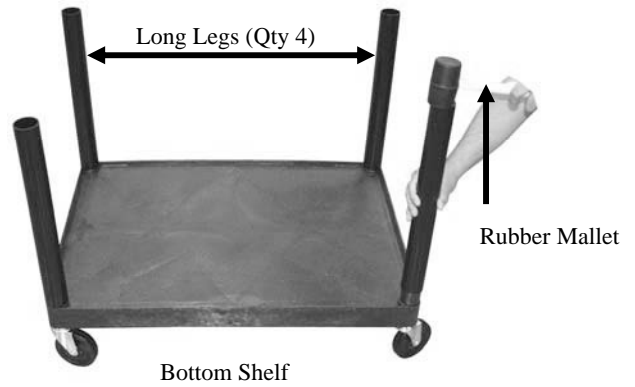
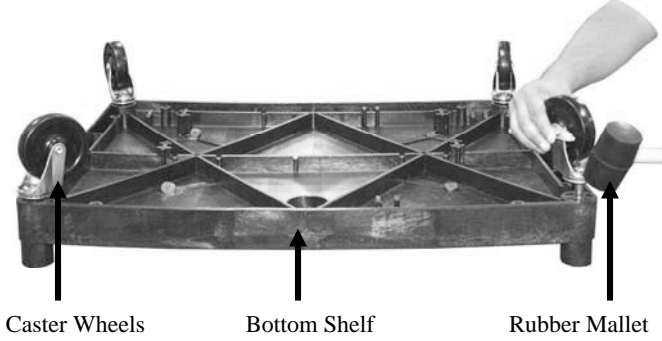

Step 1. Push the four casters firmly into the holes in each corner of the bottom shelf.

Important: Casters must be fully seated. Tap firmly with rubber mallet to properly seat casters.

Step 2. Insert four (4) long legs into each corner. Using the rubber mallet, firmly tap each leg until it is seated securely into position.

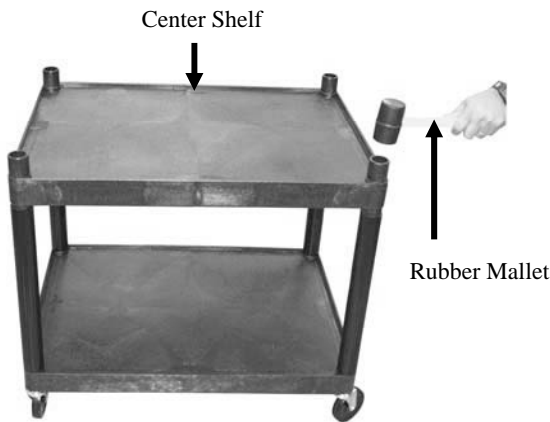

Step 3. Position the center shelf over the long legs and insert each mounting post into each leg. Using a rubber mallet, firmly hammer center shelf into legs until all four legs are seated (flush) against the surfaces of both shelves.

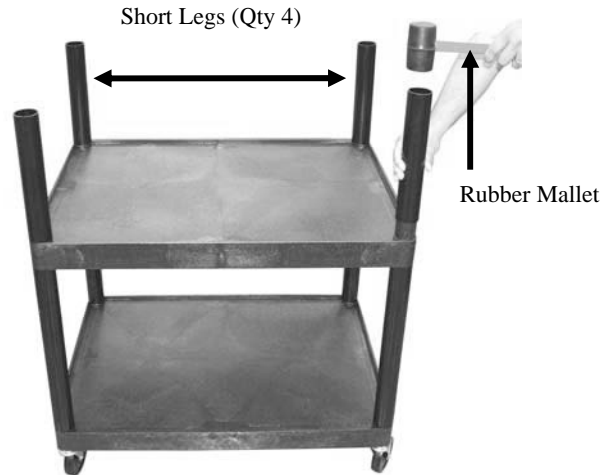

Step 4. Push remaining 4 short legs onto leg posts of center shelf. Tap firmly into place using the rubber mallet.

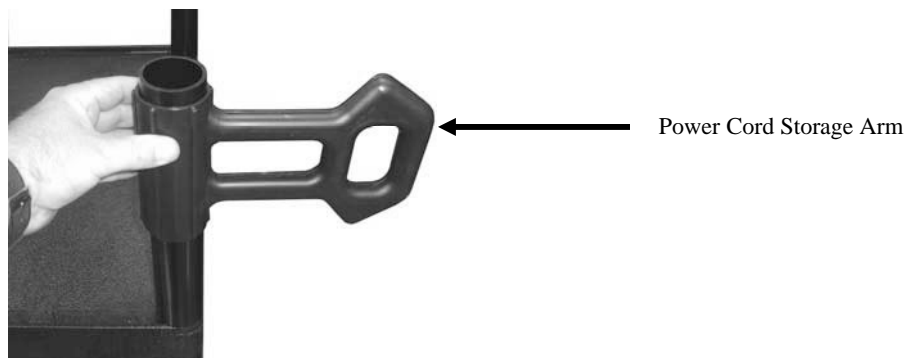

Step 5. Before installing the top shelf, slide the power cord storage arm over the short leg. The power cord storage arm will allow the user to easily store the power cord while allowing easy extraction when the cord is needed.

NOTE: The power cord storage arm must be mounted on the same side as the handle (see Electrical Assembly and Cable-Track™ Management System, page 6).

Electrical Assembly and Cable-Track Management System

Your LE40WTUD Flat Panel Display Cart incorporates the Cable-Track™ Cord Management System. This exclusive feature manages electrical cords, keeping them safely out of the way. This system includes a 3-outlet, 15 foot surge suppressing electric assembly (U.L. and C.S.A. listed) which is built into the safety handle. Please review these instructions carefully to maximize the added safety provided by Luxor's Cable-Track™ Cord Management System.

Parts List

- 1 - Surge protected power cord
- 1 - Power cord retainer clip
- 4 - Sheet metal screws
- 2 - "E"-clips
- 4 - Cord management ties

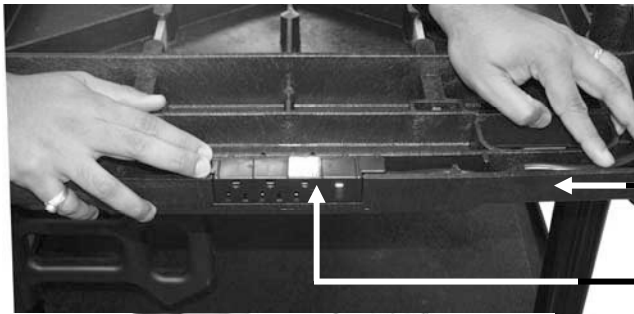

Step 1. Firmly seat the 3-plug electric assembly unit into the handle plug housing (the top shelf of the cart will need to be turned over in order to access the underside of the handle).

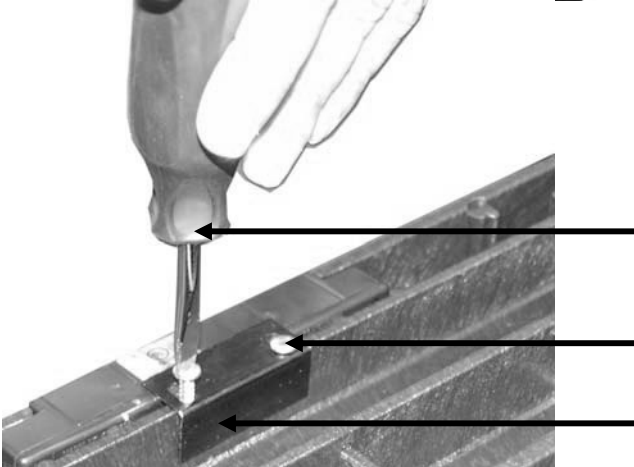

Step 2. To secure the power strip, use the power strip retaining bracket and two (2) sheet metal screws and attach using a flat tip screwdriver.

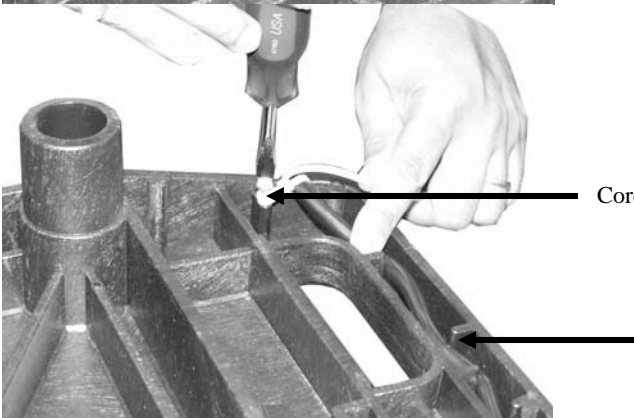

Step 3. After the power strip has been mounted, route the power cord through the cord retaining track.

Step 4. Attach the cord management tie into the starter holes using a sheet metal screw. Cut off any excess.

Step 5. Secure the power cord using the cord management tie.

Base Mount Assembly and Installation

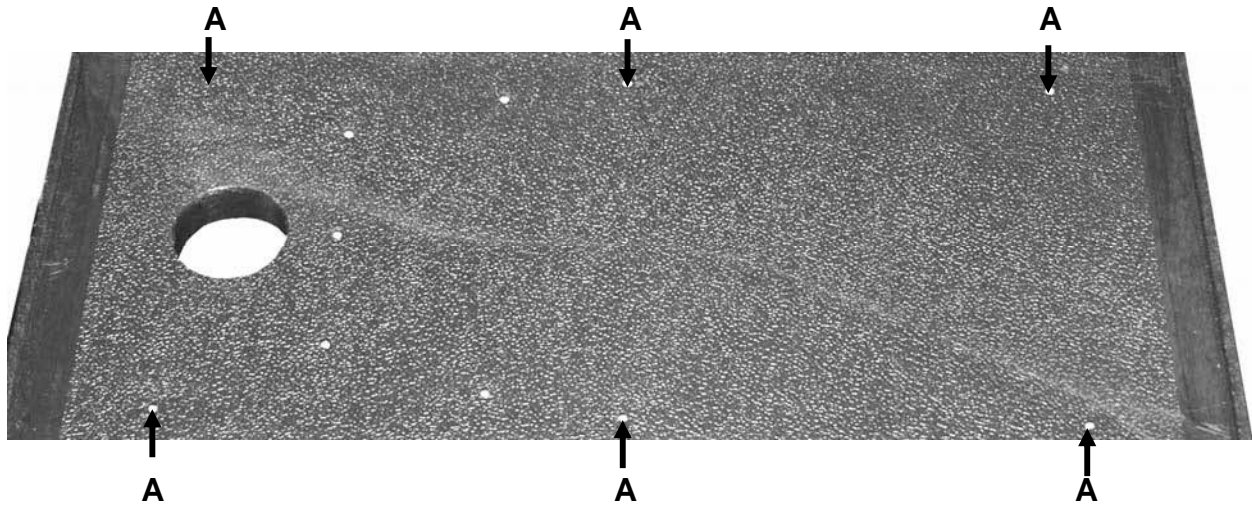

Step 1. Determine where the mounting points are on the top shelf of the Luxor Cart (Arrows).

A – Sandwich Mounting Plate Mounting Points (10x32 x 2" Socket Head Screw, M5 Flat Washer, and M5 Lock Washer Qty 6).

NOTE: It is suggested, for ease of installation, that the following steps be done by two individuals.

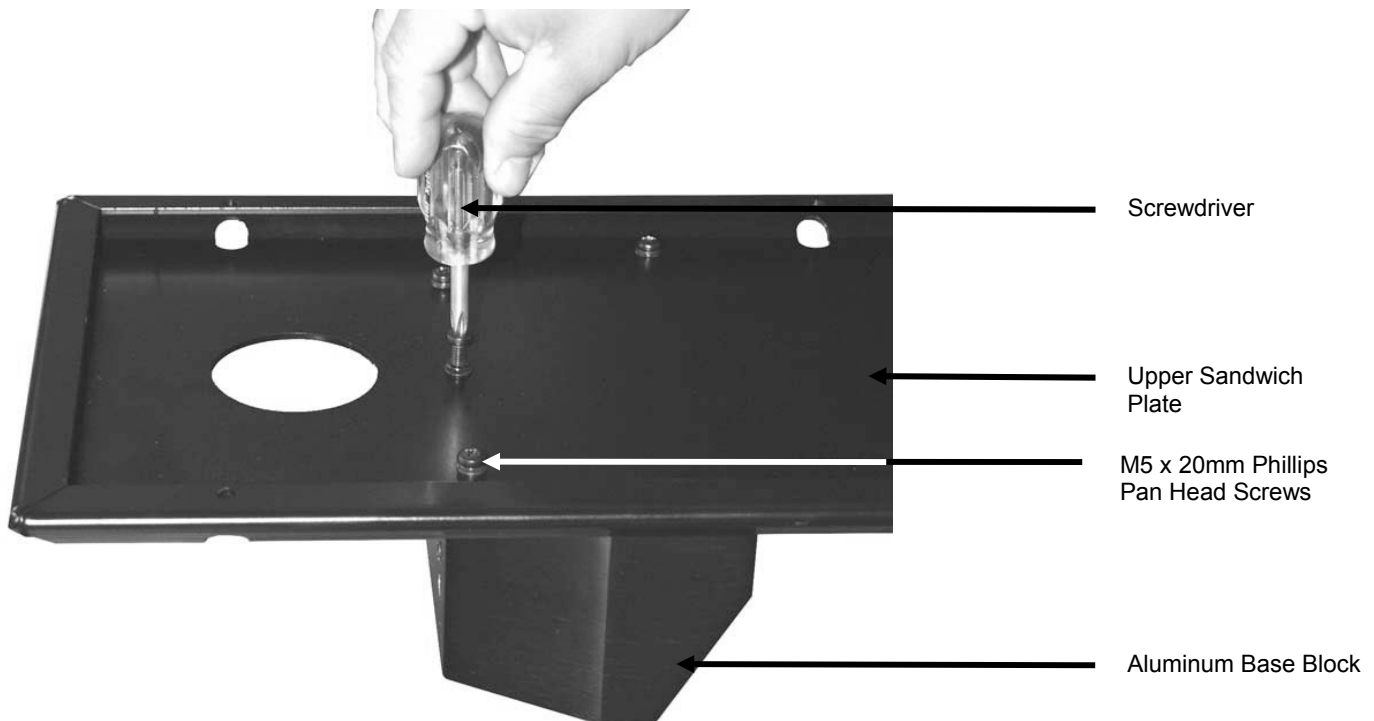

Step 2. After locating the mounting points for the aluminum block, it is now time to attach the aluminum block to the upper sandwich plate.

Step 3. Line up the mounting holes on the upper sandwich plate with the mounting holes on the aluminum block.

Step 4. Once the holes are lined up, use five (5) M5 x 20mm Phillips head screws to attach the two units together.

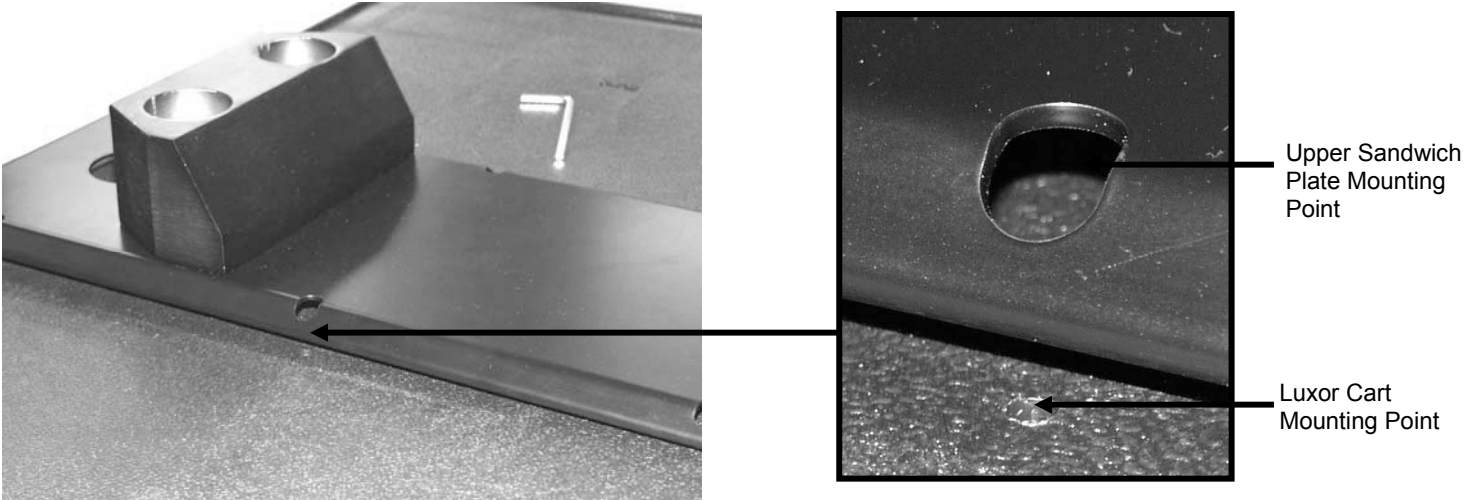

Step 5. Place the upper sandwich plate flat on the top shelf of the Luxor Cart. Line up the mounting holes that are located on the upper sandwich plate with the mounting holes that are located on the top shelf.

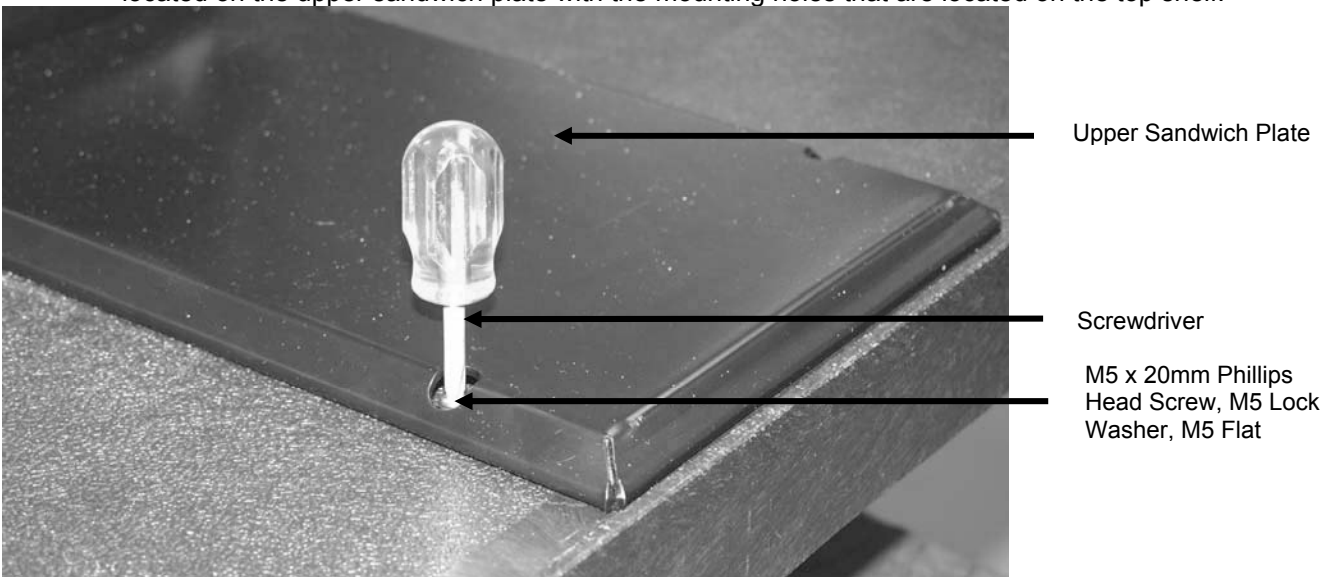

Step 6. Insert six (6) M5 x 20mm Phillips head screws, M5 lock washers and M5 flat washers into each mounting point. Once they are inserted, gently thread each screw in to their respective hole.

NOTE: At this time, have an assistant hold the lower sandwich plate in place while the screws are being threaded into place.

NOTE: The picture below shows how the hardware should be attached and in what order.

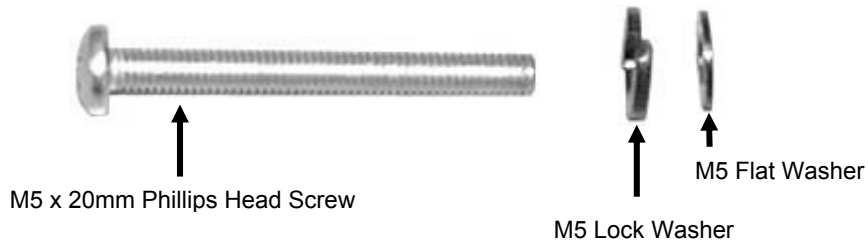

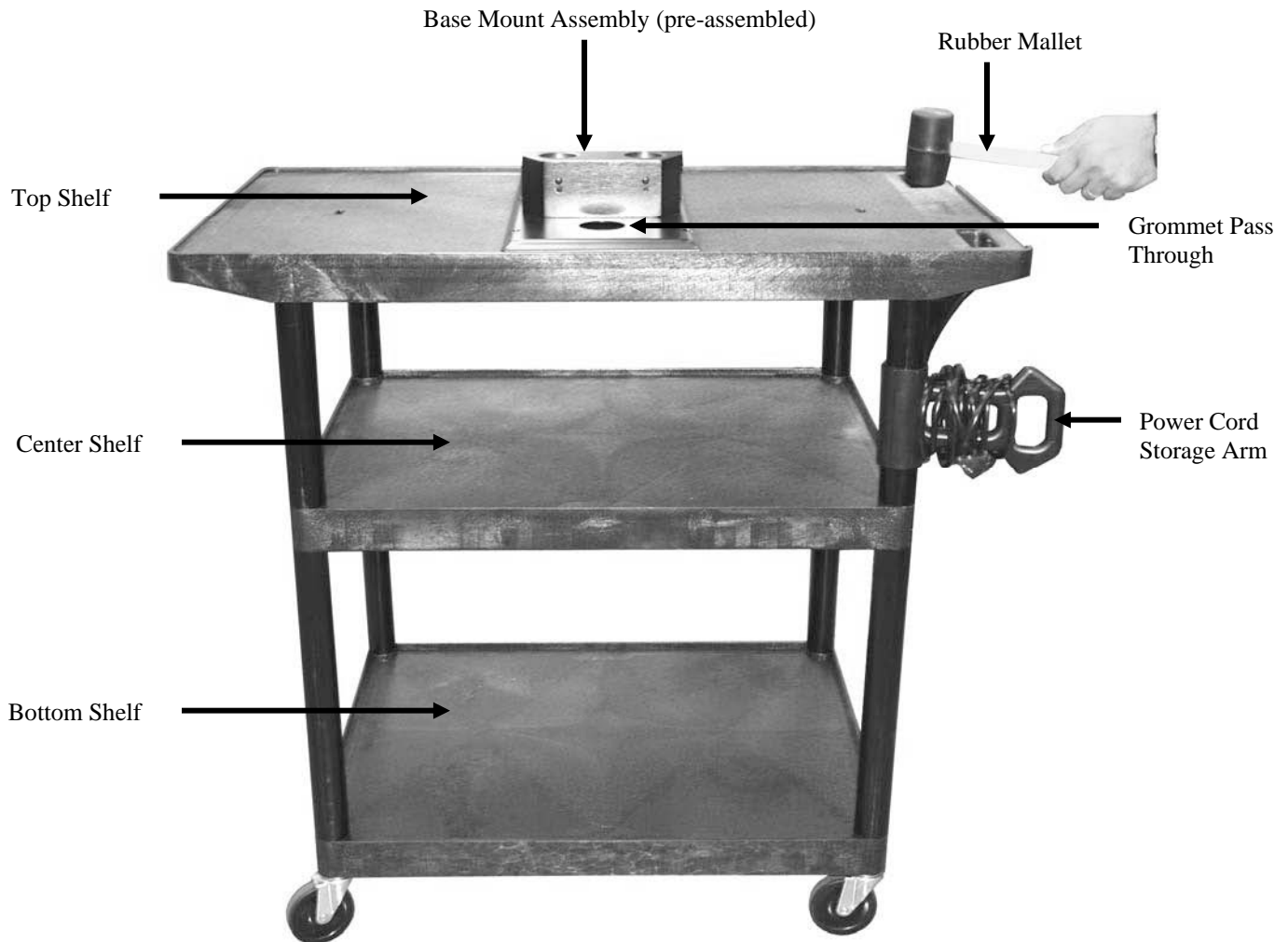
Final Assembly

- Step 1.** Place the top shelf over the four (4) short legs that are attached to the center shelf.
- Step 2.** Once the short legs are lined up with the mounting posts of the top shelf, tap the top shelf firmly onto the short legs using the supplied rubber mallet. This will complete the first part of the LE40WTUD assembly.
- Step 3.** Place the grommet pass through into the hole located behind the aluminum block.

TTS Stand Parts List

NOTE: Please familiarize yourself with all components contained herein.

NOTE: Please review all WARNING and CAUTION statements (see Page 2) before beginning the installation of the TTS Stand.

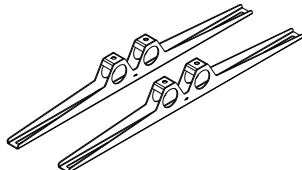
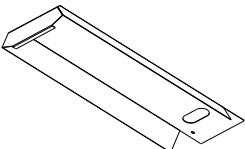
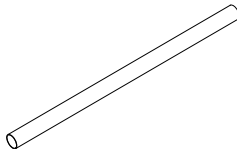
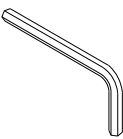
<p>Mounting Brackets (Qty 2)</p>	
<p>Back Cover (Qty 1)</p>	
<p>Thread Depth Indicator (Qty 1)</p>	
<p>Allen Wrench (Qty 1)</p>	

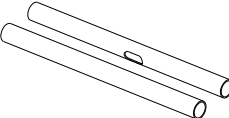
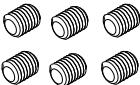
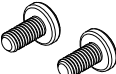
<p>Griplate™ (Qty 8)</p>	
<p>Support Poles (Qty 2)</p>	
<p>M8 X 10mm Socket Head Set Screws (Qty 6)</p>	
<p>M5 X 10 Phillips Screws (Qty 2)</p>	

TTS Stand Installation Tools

Soft Material/ Blanket

Phillips Head Screwdriver

Allen Wrench

Parts List (Cont)

NOTE: This wall mount is shipped with all proper installation hardware and components. Make sure that none of these parts are missing before beginning installation. If there are parts missing stop the installation and contact Luxor Furniture.

M4 x 16  (Qty 8)

M4 x 25  (Qty 4)

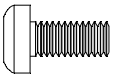
M5 x 10  (Qty 2)

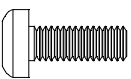
M5 x 16  (Qty 8)

M5 x 20  (Qty 6)

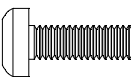
M5 x 25  (Qty 4)

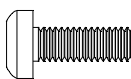
M5 x 30  (Qty 5)

M5 x 50  (Qty 4)

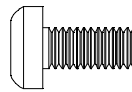
M6 x 20  (Qty 6)

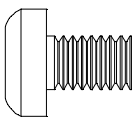
M8 x 20  (Qty 6)

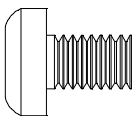
M8 x 25  (Qty 6)

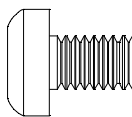
M8 x 30  (Qty 6)

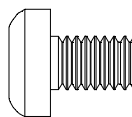
M8 x 35  (Qty 6)

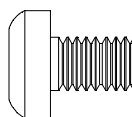
M8 x 70  (Qty 4)

NOTE: The nylon spacers may be stacked to achieve proper spacing.

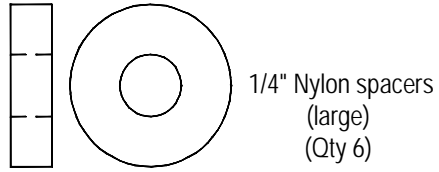

1/4" Nylon spacers
(large)
(Qty 6)



9/16" Nylon spacers
(Qty 6)

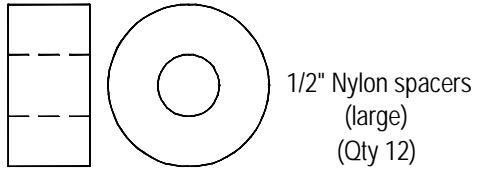

1/2" Nylon spacers
(large)
(Qty 12)

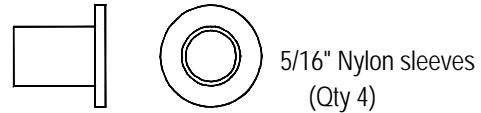

5/16" Nylon sleeves
(Qty 4)

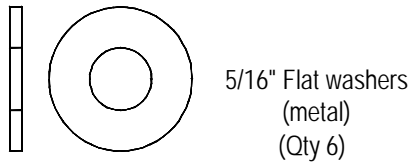

5/16" Flat washers
(metal)
(Qty 6)

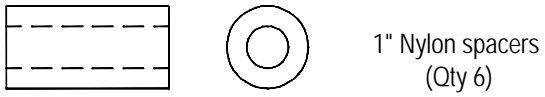

1" Nylon spacers
(Qty 6)

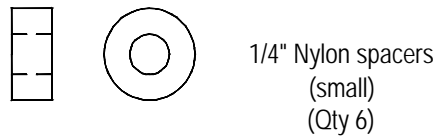

1/4" Nylon spacers
(small)
(Qty 6)

Thread Depth Indicator

1. Insert the thread depth indicator (supplied) through the thread inserts found on the back of the flat panel to make sure the inserts measure the same full depth and mark it (Figure 1).
2. Locate the correct diameter screw for the thread insert. Compare your marking to the screws (supplied).
3. If your selected screw is longer than the marking on the thread depth indicator, **DO NOT USE** this screw.
4. The screw length must not bypass the marking. Select another screw size, until you find one that comes closest to your mark without going past.

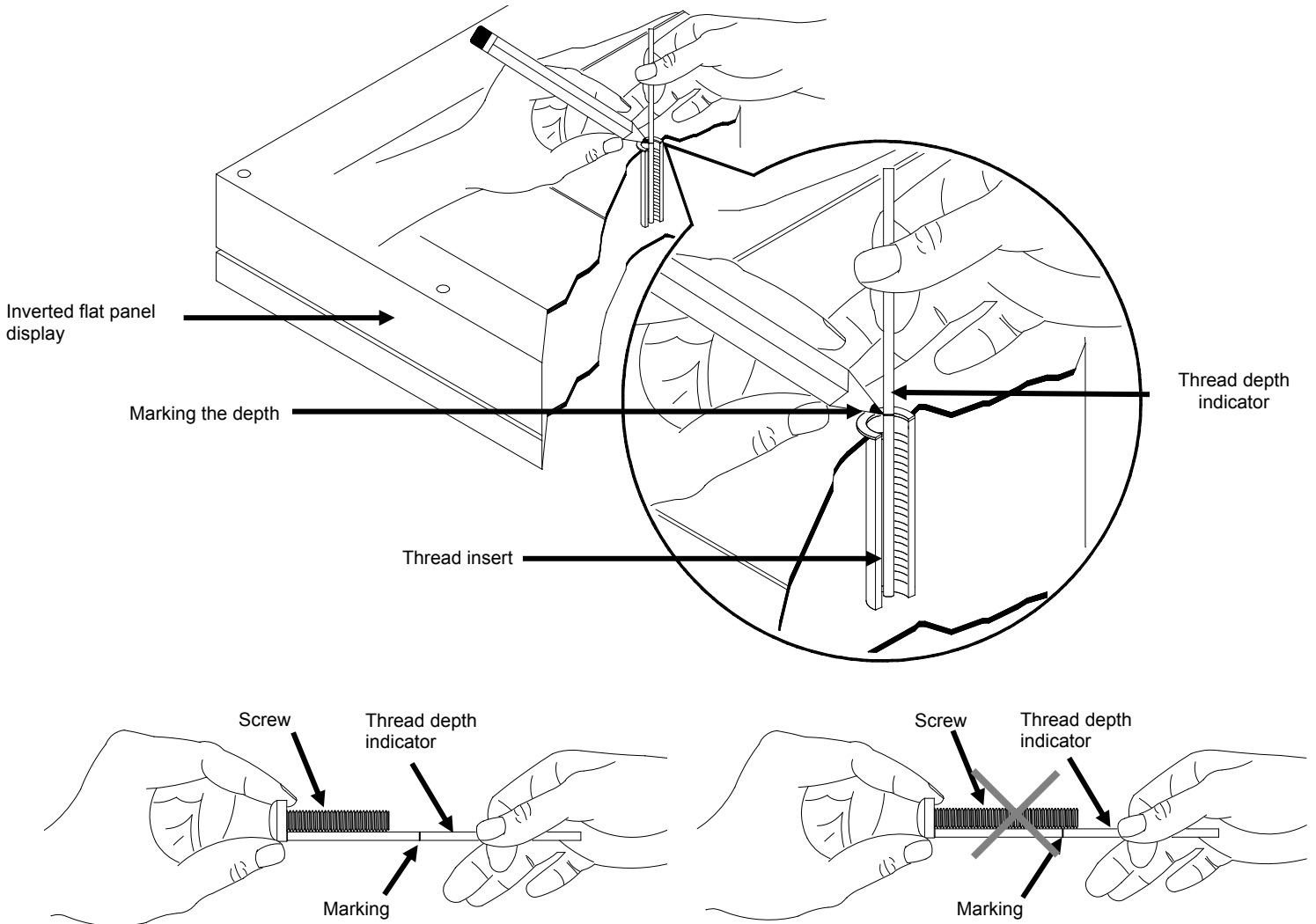

TTS Stand Assembly

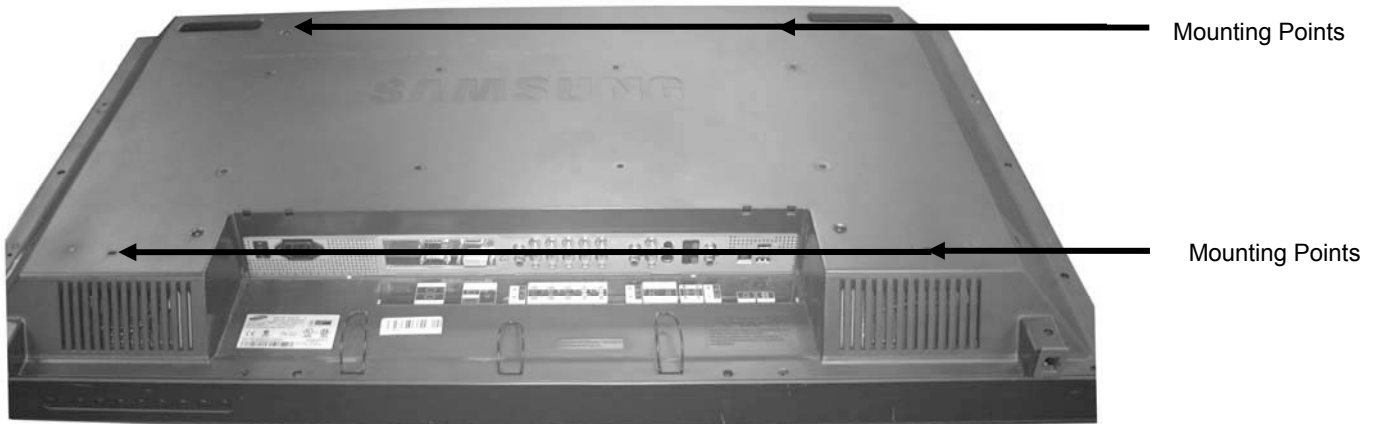

Step 1. Place the display on a soft and flat surface.

Step 2. Locate the mounting points that are on the back of the display.

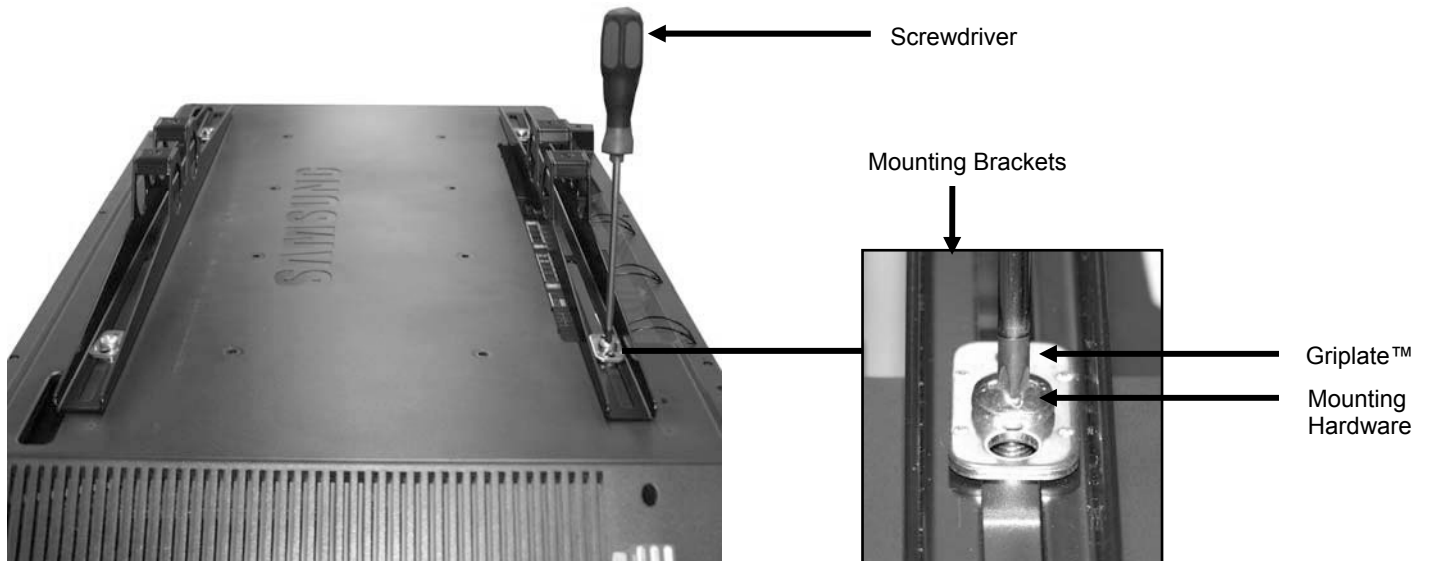

Step 3. Place the mounting brackets over the mounting points.

NOTE: Please refer to pages 10, 11 and 12 to correctly determine which mounting screws and spacers (if applicable) will be used.

Step 4. Select the appropriate hardware and attach the mounting brackets to the display using the mounting hardware and Griplate™ (flat side down).

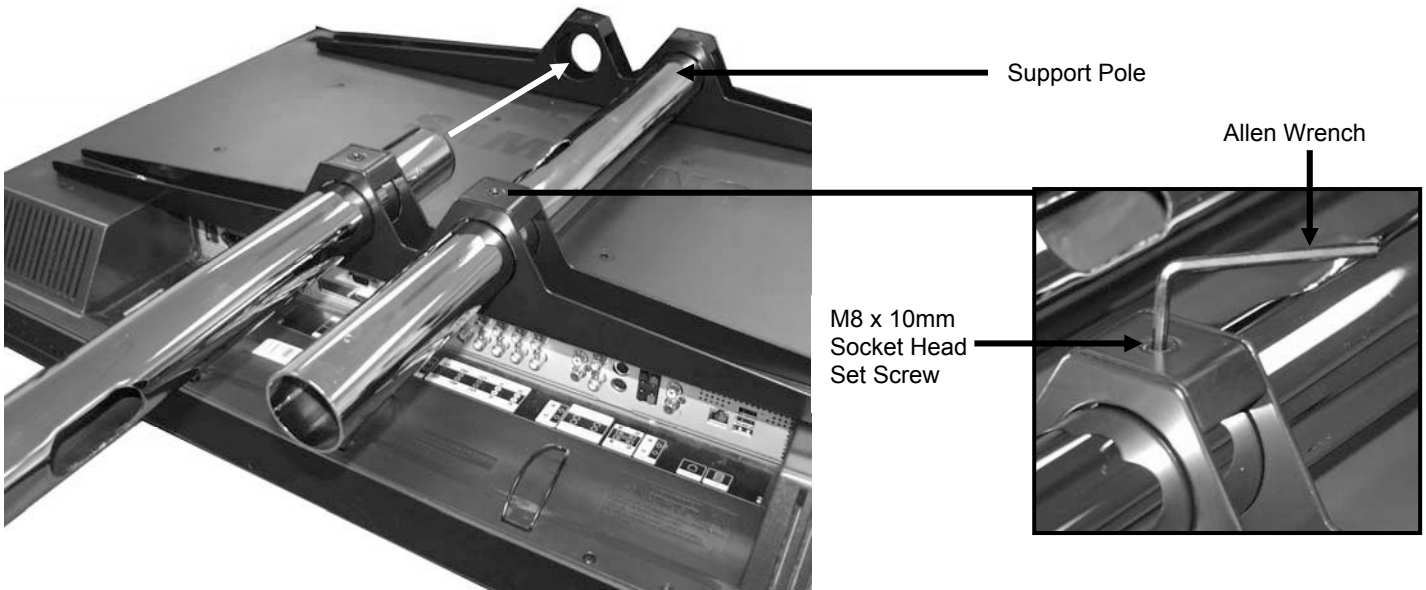

Step 5. Slide each support pole into the mounting bracket.

Step 6. Make sure the support poles are even (see **NOTE:** below), and then tighten the M8 x 10 socket head set screw with the Allen wrench (supplied).

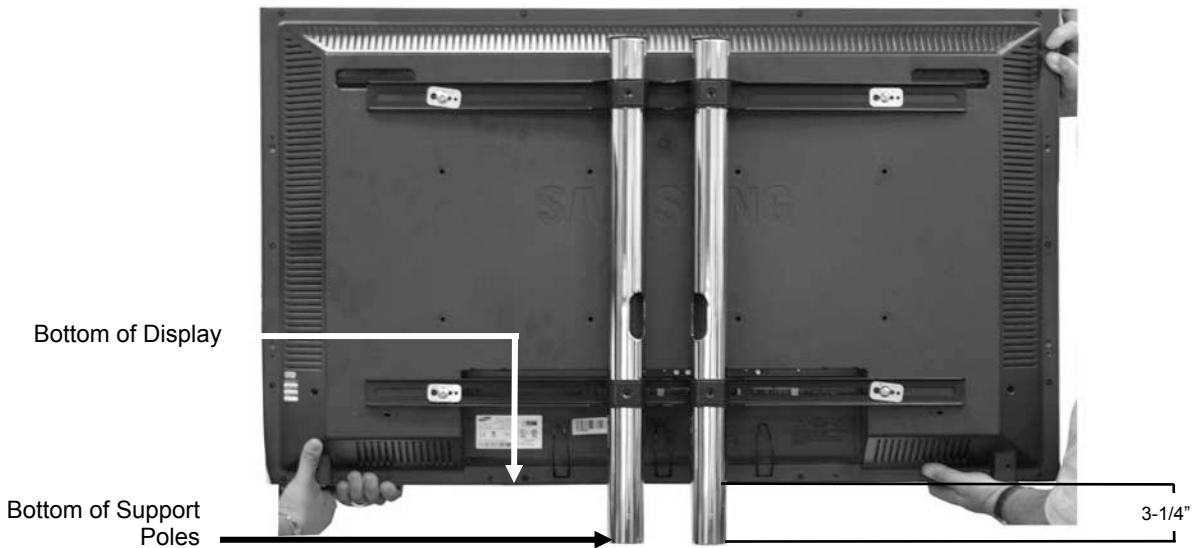

NOTE: Before tightening the M8 x 10mm socket head screws and placing the display assembly into the aluminum mounting block, make sure that the measurement from the bottom of the support poles to the bottom of the display measures 3-1/4". This measurement will allow for correct and even spacing once the display assembly is placed into the aluminum block.

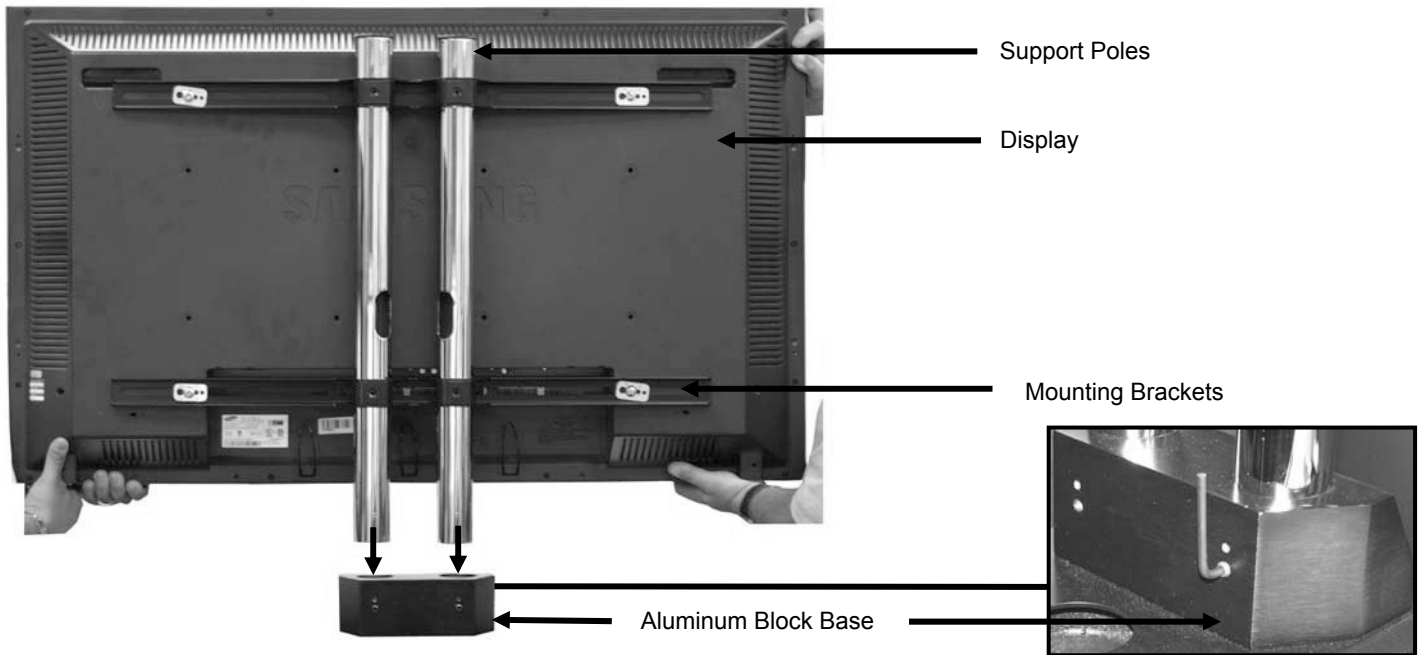

TWO PEOPLE WILL BE NEEDED FOR THE FOLLOWING STEPS.

Step 7. After the assembly has been put together, make sure all the hardware is tight.

Step 8. Two people should carefully lift the assembly and place the bottom of the support poles into the aluminum block base.

Step 9. Once the support poles are seated, tighten the M8 x 10mm socket head set screws using the Allen wrench (supplied).

Back Cover Plate Installation

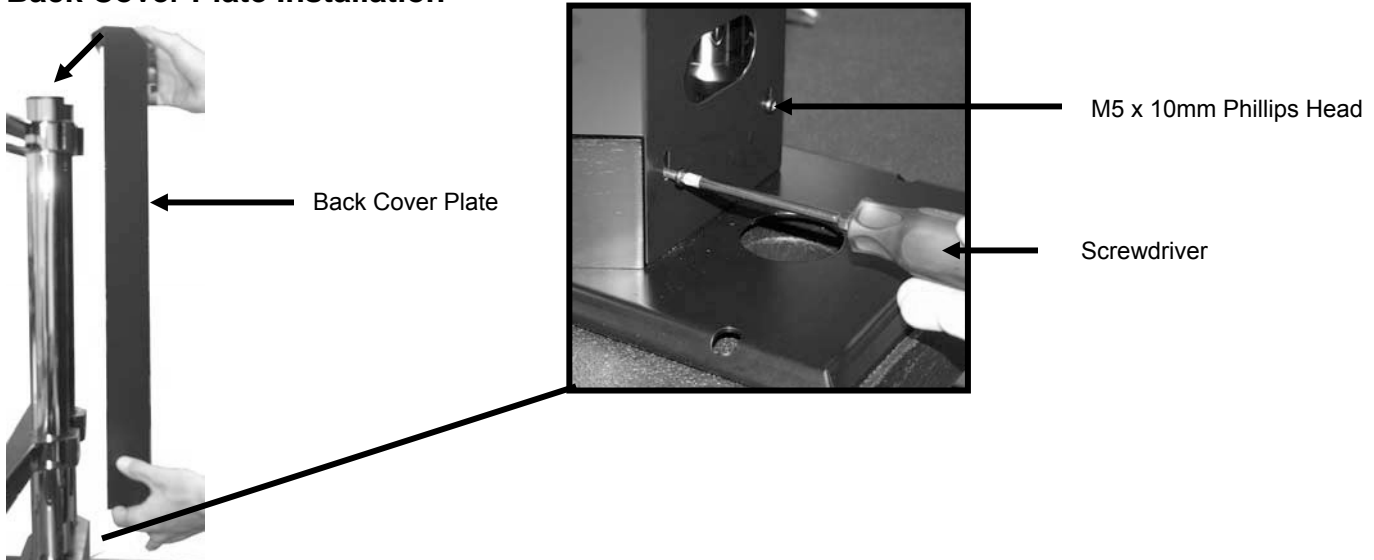

Step 1. Place the back cover plate over the top of the support poles and let it rest on top.

Step 2. Insert and tighten two (2) M5 x 10mm Phillips head screws at the base of the plate.