

Instruction Sheet - **Endura Mobile Cabinet Tables**
 Models LE-34C, LE-40C, LE-42C, LE-48C and LE-54C



Customer Service Department
 Luxor
 2245 Delany Road
 Waukegan, IL 60087
 Ph: 847/244-1800 • 800/323-4656
 Fax: 847/244-1818 • 800/327-1698



LE-54C



LE-40C



LE-42C

PARTS LIST

Models LE-34C, LE-40C, LE-42C, LE-48C, LE-54C

- | | |
|------------------------------------|----------------------|
| 1 - Top shelf w/handle | 1 - Door in frame |
| 1 - Center shelf w/eight leg posts | 1 - Grommet cap |
| 1 - bottom shelf w/caster sockets | 1 - Cord guide cover |
| 4 - Short legs | 1 - Grommet ring |
| 4 - Long legs | 1 - Rubber band |
| 2 - Cabinet side panels | |
| 1 - Back panel | |
| 4 - Casters 2 with brake | |

Tools Required:

Rubber mallet

1 IMPORTANT
 The electrical unit should be assembled first.

If your Endura Cabinet Table does not have the Electrical Assembly and Cable-Track™ Cord Management System, start by closing the electrical plug housing in the handle of the top shelf as illustrated below.

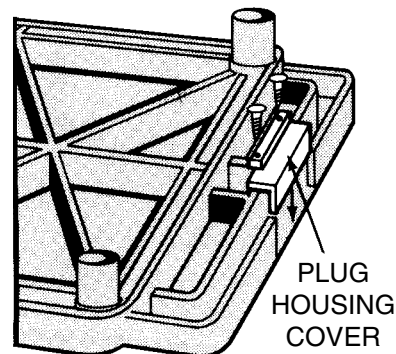

Units with electric receive following parts:

- 1- Cord guide cover
- 1- Cord wrap
- 4- Cord ties
- 1- L-bracket
- 6- Screws
- 1- Power cord

Units without electric receive following parts:

- 1- Cord guide cover
- 2- Screws
- 1- Plug housing cover

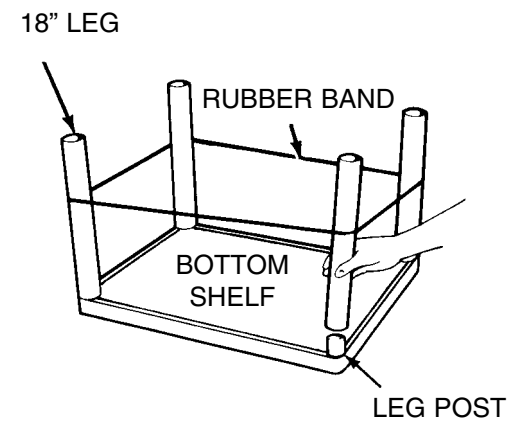

2
 With bottom shelf facing up push all four 18" legs onto leg posts. Using rubber mallet hammer legs firmly into position. Legs must be seated (flush) against the shelf surface. Place rubber band around legs to aid in the assembly of cabinet side panels and doors.

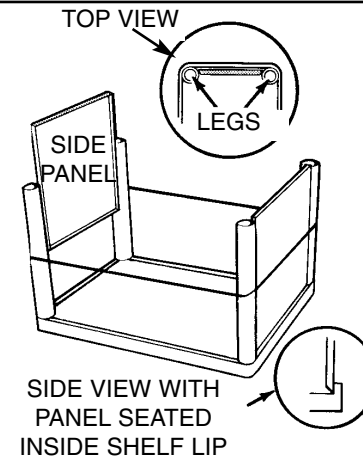

3
 Install the side panels first. Slide panels down between legs until they are nested inside the shelf lip and flush against the shelf surface. Rubber band will hold legs and side panels in place while installing back panel and front door.

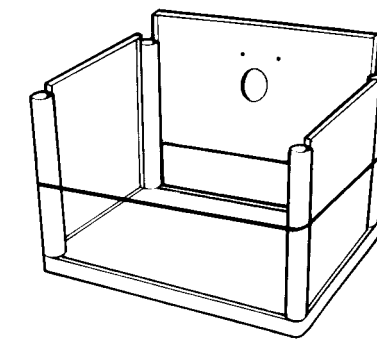

4
 Install the back panel in the same manner as shown in Step #3. NOTE: Cabling hole in back panel should be toward the top.

NOTE: Models LE-40C, LE-48C, and LE-54C have double doors.

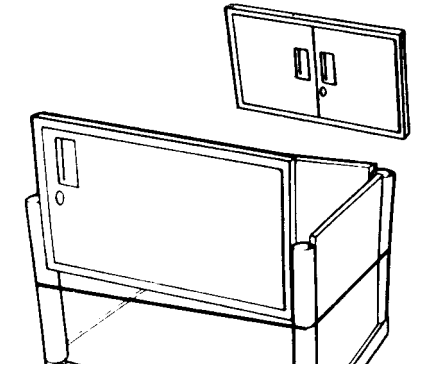

5
 Install door panel same as back panel, with door handle at top.

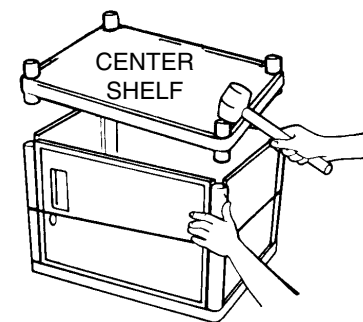

6
 Begin seating of center shelf by holding door panel, leg and side panel as illustrated. Gently tap corner post into leg. Repeat on all 4 sides until all posts are partially inserted into legs. Now repeat hammering action more firmly going around to each shelf post and driving the leg posts more securely into the legs.
 Top of panels and door frame must be nested into the underside of the center shelf lip in the same manner as the bottom shelf.

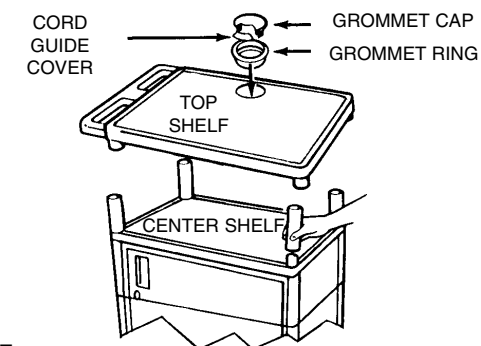

7
 Push remaining 4 legs onto center shelf posts as illustrated. Place top shelf (with handle) onto legs. Insert leg posts into legs of top shelf. Using rubber mallet, firmly hammer top shelf into legs until all four legs are seated against shelf surface. install grommet ring and grommet cap into top of shelf. For tables with electric assembly, snap off cord guide cover from grommet cap to allow equipment plug to be run through grommet. Insert grommet cap into grommet ring. Remove rubber band.

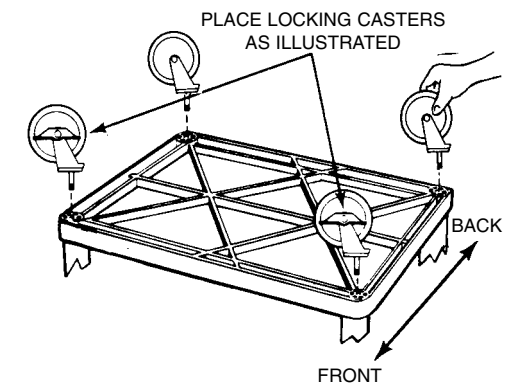

8
 Push the four casters firmly into the holes in each corner of the bottom shelf. Important: casters must be fully seated. Tap firmly with rubber mallet to properly seat casters. Turn your Endura Table right side up.



Instructions For - Electrical Assembly

Cable-Track™ Management System and Cord Wrap

Your Endura mobile equipment table incorporates the Cable-Track™ cord management system. This exclusive feature manages electrical cords, keeping them safely out of the way. This system includes a 3-outlet, 15 foot surge suppressing electric assembly (U.L. and C.S.A.

listed) which is built into the safety handle. Please review these instructions carefully to maximize the added safety provided by Luxor's Cable-Track™ cord management system.

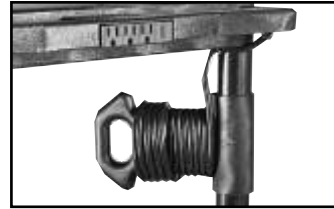

Parts List

1 - Surge protected power cord	1 - Power cord retainer clip
1 - Cord wrap	2 - "E"-clips
4 - Cord management ties	4 - Sheet metal screws

ILLUSTRATION A

Important

1. The electrical unit should be assembled first.

Cord wrap must be installed on leg before assembly of complete unit.
*See below (See Illus. B).

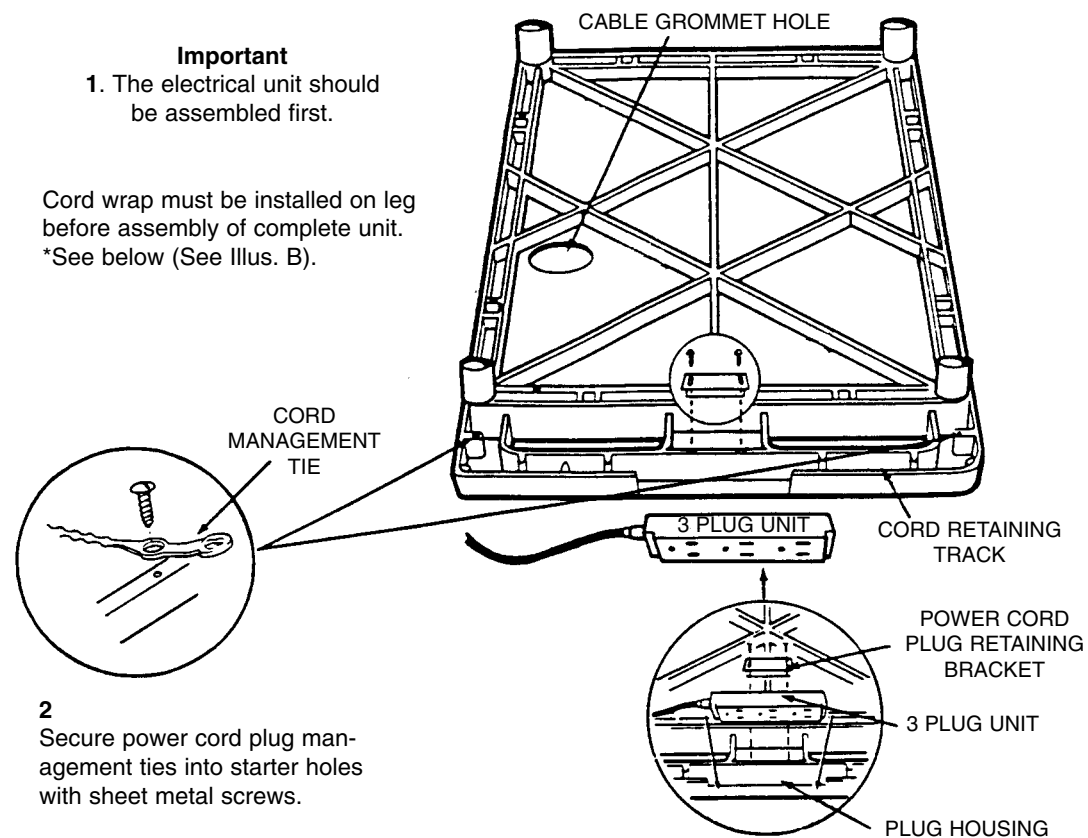

3. Firmly seat electric assembly 3 plug unit into handle plug housing as illustrated. Secure with power cord plug retaining bracket.

ILLUSTRATION B

Install correct size leg on top shelf then slide cord wrap down over leg into position.

4. Thread power cord through cord retaining track, secure with cord management ties by wrapping tie around cord and fastening. Cut off any unnecessary extra length of tie. Wrap remaining cord around the cord wrap bracket. For safety and new appearance, secure cord plug to cord by utilizing plug snap.

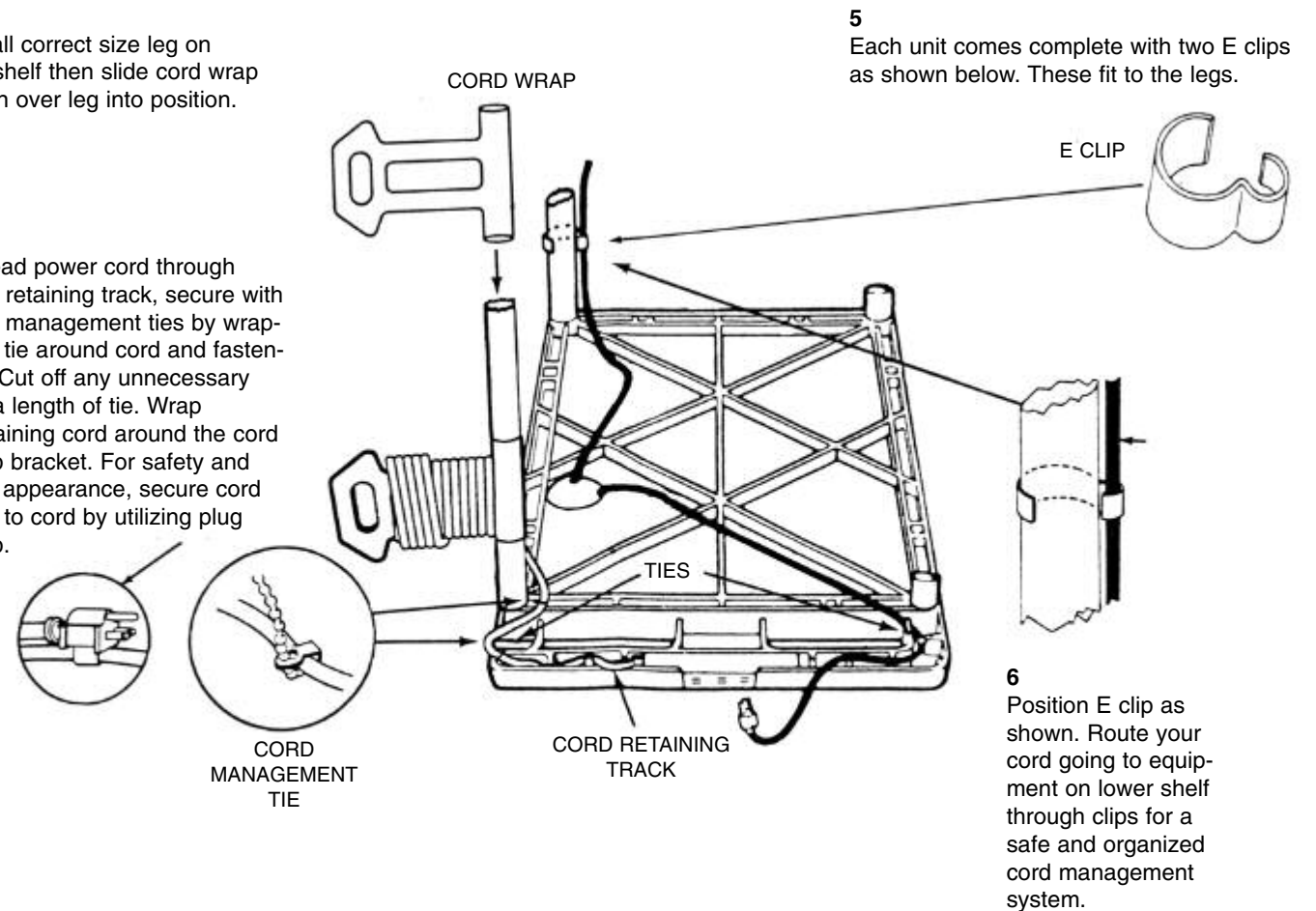

5. Each unit comes complete with two E clips as shown below. These fit to the legs.

6. Position E clip as shown. Route your cord going to equipment on lower shelf through clips for a safe and organized cord management system.