

Instruction Sheet

Endura Models LEM32K, LEM32KO, and LEM32TWRK



Customer Service Dept.
2245 Delany Road
Waukegan, IL 60087
Ph: 847/244-1800 • 800/323-4656
Fax: 847/244-1818 • 800/327-1698



- 1 - Shelf w/handle
- 1 - Bottom shelf w/cut-out
- 4 - 23½" Legs
- 2 - Casters
- 2 - Casters w/brake
- 1 - Keyboard Shelf
- 2 - Runners
- 1 - "L" bracket for power cord
- 1 - Power cord
- 1 - Power cord bracket
- 1 - Plastic cord wrap
- 1 - Grommet

Parts list

- 2 - "E" clips
- 4 - Cord ties
- 8 - Self tapping screws (in runner package)
- 6 - 5/8" Sheet metal screws
- 14 - Sheet metal screws (in runner package)

TOOLS REQUIRED:

- 1 - Rubber mallet
- 1 - Slotted screwdriver
- 1 - Phillips screwdriver

- LEM32KO only**
- ADD:
- 1 - Small Top Shelf
 - 1 - Small Bottom Shelf
 - 4 - 8" Legs
 - 4 - 2" twin wheel casters

- LEM32TWRK only**
- 4 - 25" Legs
 - 1 - set CPU Holder
 - 4 - Wing Nuts
 - 5 - 2" Twin wheel set

1 Instructions For Electric Assembly

1. The electric unit should be assembled first. Cord wrap must be installed on leg before assembly of complete unit. See below.

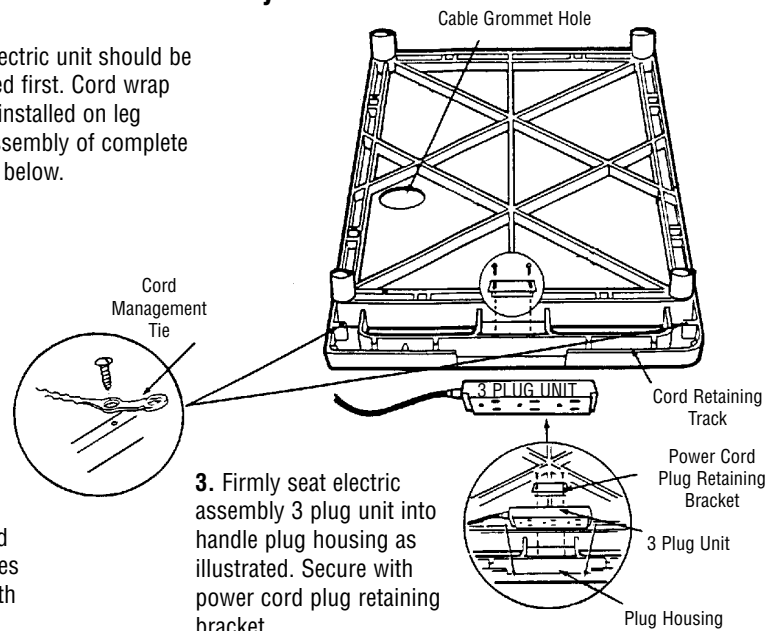

3. Firmly seat electric assembly 3 plug unit into handle plug housing as illustrated. Secure with power cord plug retaining bracket.

2. Secure power cord plug management ties into starter holes with sheet metal screws.

Install correct size leg on top shelf then slide cord wrap down over leg into position.

4. Thread power cord through cord retaining track, secure with cord management ties by wrapping tie around cord and fastening. Cut off any unnecessary extra length of tie. Wrap remaining cord around the cord wrap bracket. For safety and neat appearance, secure cord plug to cord by utilizing plug snap.

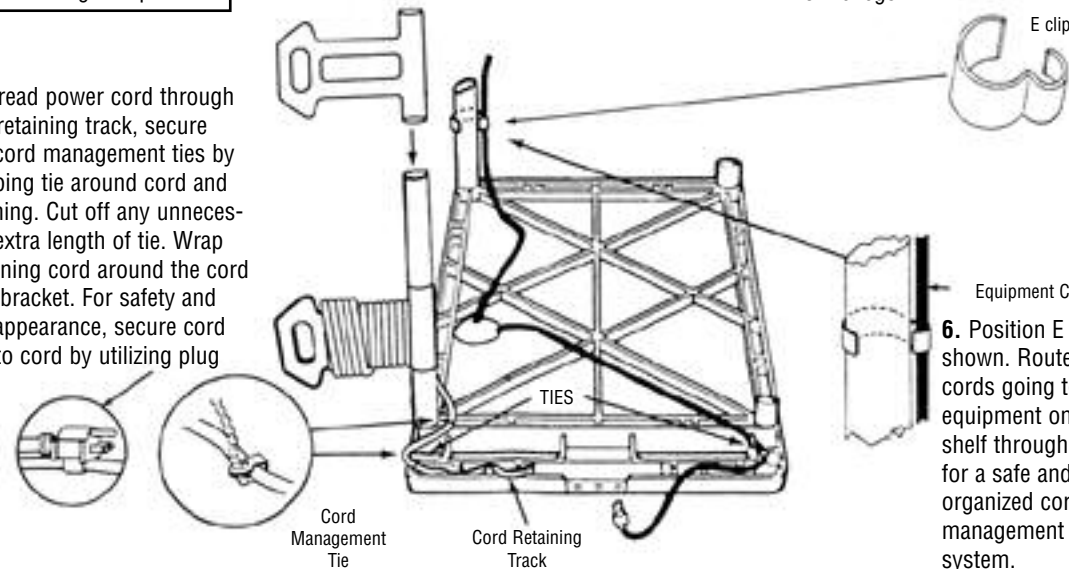

5. Each unit comes complete with two E clips as shown above. These fit to the legs.

6. Position E clip as shown. Route your cords going to equipment on lower shelf through clips for a safe and organized cord management system.

2

1. Mount L-brackets to keyboard supports on the bottom of top shelf using 8 sheet metal screws. Be sure the brackets are pointing towards each other.

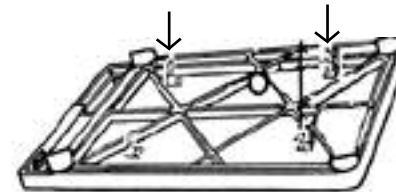

2. Attach runner support brace to the side of the runners by inserting a self tapping screw through the larger hole on the support brace. The lip of the brace will be resting on top of the runner.



3. Slide the runner support braces onto the L-brackets and attach them together with self tapping screws. Use the third hole on the L-brackets.



4. Extend the slides on the runners fully out and attach the keyboard to the slides using six sheet metal screws.

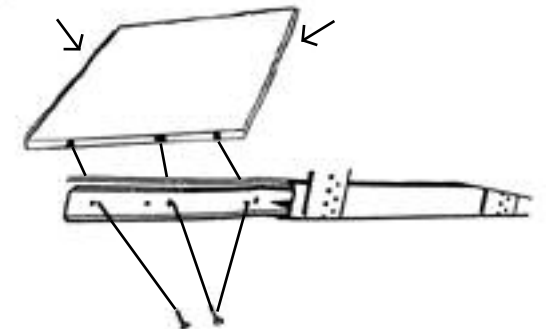

3 LEM32K only

Bottom Shelf
Front
Back
Legs
Top Shelf

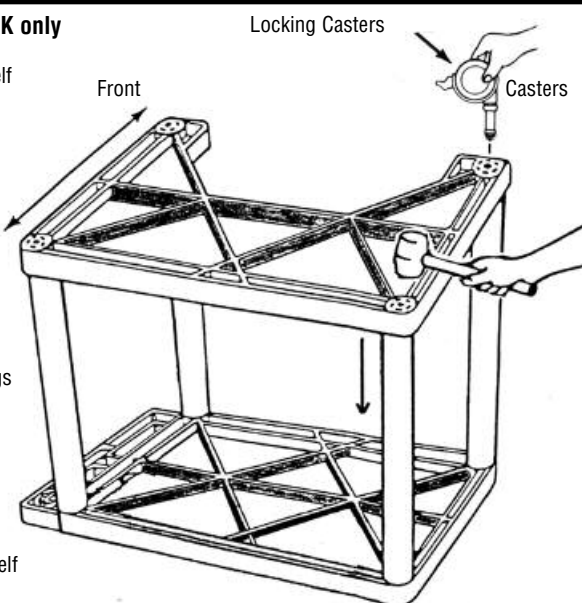

3 LEM32TWRK only

Position bottom shelf with open cut-out facing toward the front, ribbed side up, over the 4 legs of the top shelf as illustrated. Insert leg posts into legs. Using a rubber mallet, firmly hammer bottom shelf into legs until all four legs are seated (flush) against the surfaces of both shelves. Insert side plates so bolts come out of bottom of shelf with each lip facing in. Secure in place with wing nuts. Tighten when CPU holder is in place.

