

INSTRUCTION SHEET

Endura Models LEM-32K and LEM-32KO



Customer Service Dept.
2245 Delany Road
Waukegan, IL 60087
Ph: 847/244-1800 • 800/323-4656
Fax: 847/244-1818 • 800/327-1698



LEM32K

PARTS LIST

- 1 - Shelf w/handle
- 1 - Bottom shelf w/cut-out
- 4 - 23½" Legs
- 2 - Casters
- 2 - Casters w/brake
- 1 - Keyboard Shelf
- 2 - Runners
- 1 - "L" bracket for power cord
- 1 - Power cord
- 1 - Power cord bracket
- 1 - Plastic cord wrap
- 1 - Grommet

- 2 - "E" clips
 - 4 - Cord ties
 - 4 - Self tapping screws (in runner package)
 - 6 - 5/8" Sheet metal screws
 - 14 - Sheet metal screws (in runner package)
- TOOLS REQUIRED:**
- 1 - Rubber mallet (included)
 - 1 - Slotted screwdriver
 - 1 - Phillips screwdriver

- LEM32KO ONLY
- ADD:
- 1 - Small Top Shelf
 - 1 - Small Bottom Shelf
 - 4 - 8" Legs
 - 4 - 2" twin wheel casters

1 Instructions For Electric Assembly

1. The electric unit should be assembled first. Cord wrap must be installed on leg before assembly of complete unit. See below.

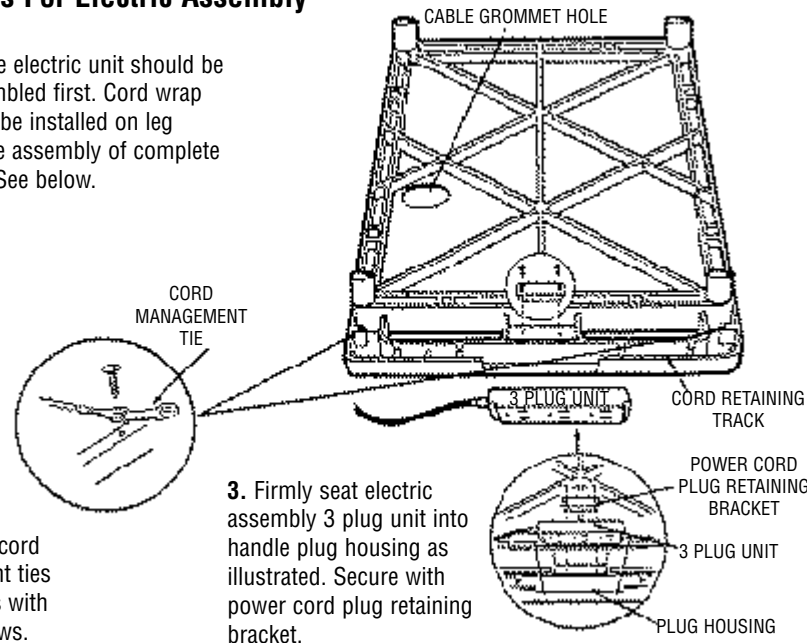

3. Firmly seat electric assembly 3 plug unit into handle plug housing as illustrated. Secure with power cord plug retaining bracket.

2. Secure power cord plug management ties into starter holes with sheet metal screws.

Install correct size leg on top shelf than slide cord wrap down over leg into position.

4. Thread power cord through cord retaining track, secure with cord management ties by wrapping tie around cord and fastening. Cut off any unnecessary extra length of tie. Wrap remaining cord around the cord wrap bracket. For safety and neat appearance, secure cord plug to cord by utilizing plug snap.

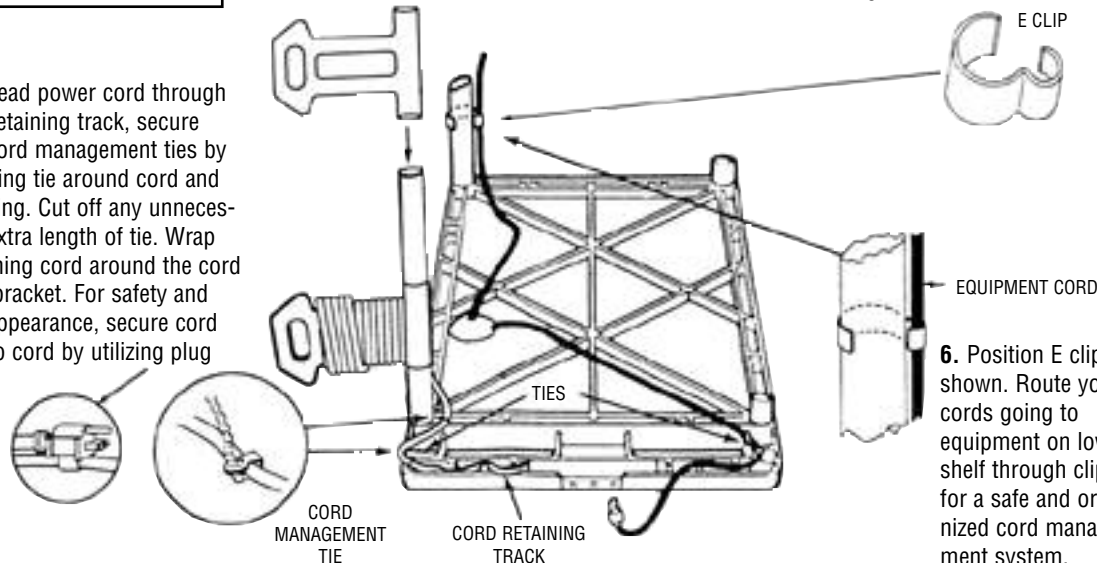

5. Each unit comes complete with two E clips as shown above. These fit to the legs.

6. Position E clip as shown. Route your cords going to equipment on lower shelf through clips for a safe and organized cord management system.

2

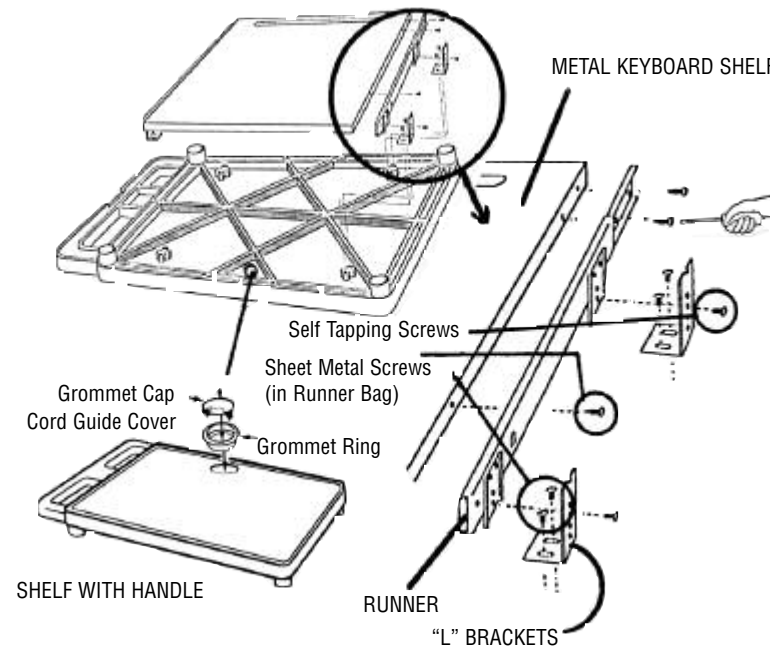

1. See electric assembly instructions at far left of this sheet.

2A. To install metal pull-out shelf, first turn workstation top shelf upside down, locate the four "L" bracket support members as shown in step 1.

2B. Secure "L" brackets to "L" bracket support members using two 5/8 sheet metal screws per bracket. Do not fully tighten screws at this time. **Note:** "L" brackets must face each other pointing in towards center of workstation shelf.

2C. Next, identify left runner from right runner. This is done by extending runner fully to locate the three holes used to attach to metal shelf. This portion of the runner with holes must face toward front of metal shelf. Turn metal shelf upside down and install runners on each side using three sheet metal screws on each side. **Special Note:** Remember all assembly is being done upside down. Position assembled shelf and runner between "L" brackets to determine proper spacing of "L" brackets. Carefully remove metal shelf and fully tighten "L" brackets.

2D. Use self-tapping screws to secure runner to "L" brackets. For maximum clearance use hole on "L" bracket that is farthest away from workstation top shelf.

2E. Install grommet ring by tapping into place with rubber mallet. Snap off cord guide cover from grommet cap so equipment plug may be run through grommet to plug unit, then insert grommet cap into grommet ring.

3A. Lay top shelf (with handle) ribbed side up on a smooth surface. Push all 4 legs onto leg posts. 3B. Position bottom shelf with open cut-out facing toward the front, ribbed side up, over the 4 legs of the top shelf as illustrated. Insert leg posts into legs. Using a rubber mallet, firmly hammer bottom shelf into legs until all four legs are seated (flush) against the surfaces of both shelves.

3C. Push the four casters firmly into the holes in each corner of the bottom shelf. **Important:** casters must be fully seated. Tap firmly with rubber mallet to properly seat casters. Turn your Endura workstations right side up. It is now ready to use.

3

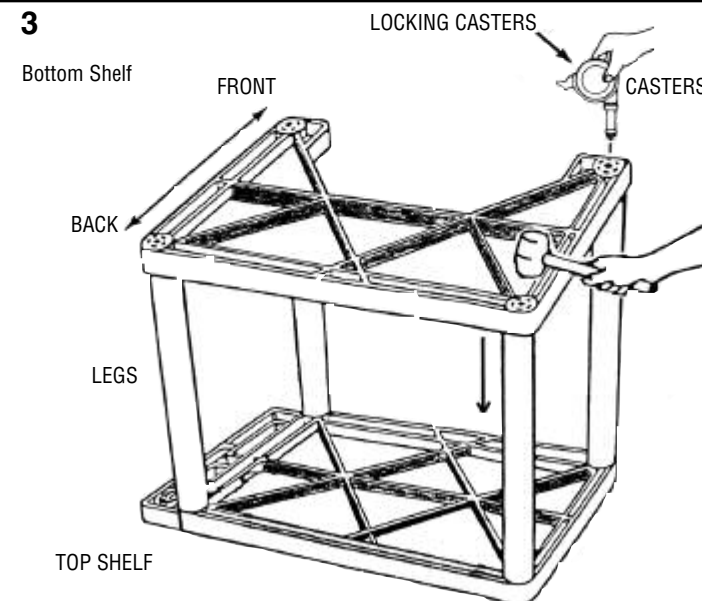

LEM-32KO ONLY

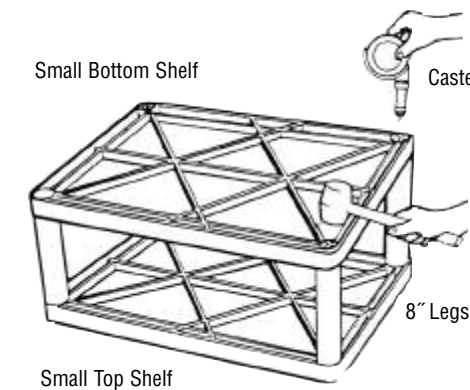

Position bottom shelf, ribbed side up, over the 4 legs and insert legs posts into legs. Using a rubber mallet, firmly hammer shelf into legs until all four legs are seated (flush) against the surfaces of both shelves.

Push the four casters firmly into the holes in each corner of the bottom shelf.

Important: casters must be fully seated. Tap firmly with rubber mallet to properly seat casters. Turn your Endura stand right side up. It is now ready to use.