

Instruction Sheet

Endura Models LEM-32T, LEM-32TWRT & LE-MST



Customer Service Dept
2245 Delany Rd
Waukegan, IL 60087
Ph: 847/244-1800 • 800/323-4656
Fax: 847/244-1818 • 800/327-1698



PARTS LIST

LEM-32T

- 1- Terminal Platform
- 1- Set Short Legs 8"
- 1- Middle Shelf w/Handle
- 1- Set Long Legs 17½"
- 1- Bottom Shelf w/Cut-Out
- 1- Set 4" Casters, 2 w/brake
- 2- Cord set grommets

LE-MST

- 1- Terminal Platform
- 1- Set Short Legs 8¾"
- 1- Middle Shelf w/Handle
- 1- Set Long Legs 20"
- 1- Bottom Shelf w/Cut-Out
- 1- Set 4" Casters, 2 w/brake
- 2- Cord set grommets

LEM-32TWRT

- 1- Terminal Platform
- 1- Set Short Legs 8"
- 1- Middle Shelf w/Handle
- 1- Set Long Legs 20"
- 1- Bottom Shelf w/Cut-Out & Slots
- 1- Set (5) 2" Casters, 2 w/brake
- 2- Cord set grommets
- 2- 9½"x20" side plates
- 4- Wing nuts

Tools Required:
Rubber Mallet
Slotted Screwdriver

IMPORTANT

The electrical unit should be assembled first.

If your Endura Workstation has the Electrical Assembly and Cable-Track Cord Management System, see reverse side of this sheet for instructions.

If your Endura Workstation **does not have** the Electric Assembly and Cable-Track Cord Management System, start by closing the electrical plug housing in the handle of the middle shelf as illustrated.

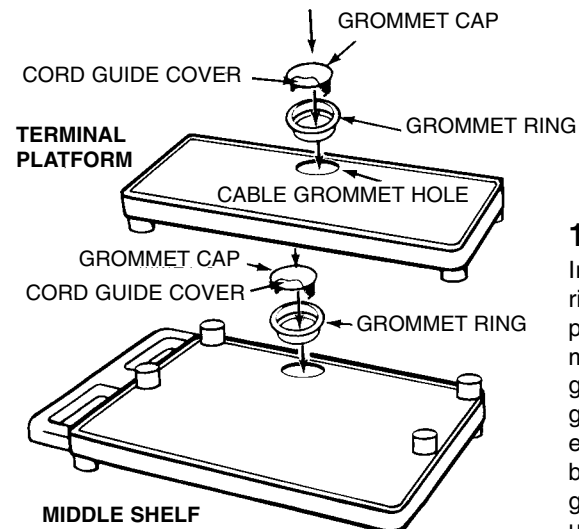
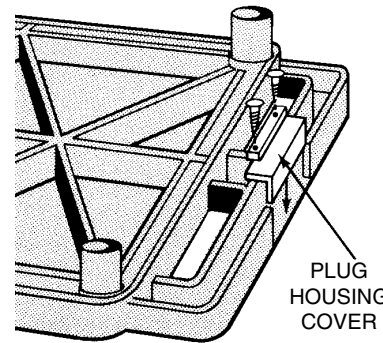

1. Install grommet rings by tapping into place with rubber mallet. Snap off cord guide cover from grommet cap so equipment plug may be run through grommet to plug unit, then insert grommet cap into grommet ring.

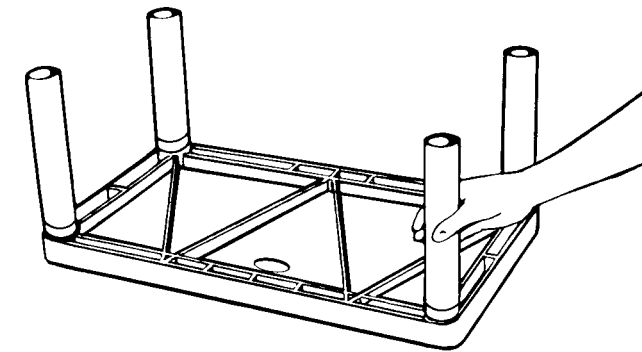

2. Lay terminal platform (long narrow shelf with grommet hole) ribbed side up on a smooth surface. Push 1 set of short legs onto leg posts. Set aside temporarily and continue with step No. 3.

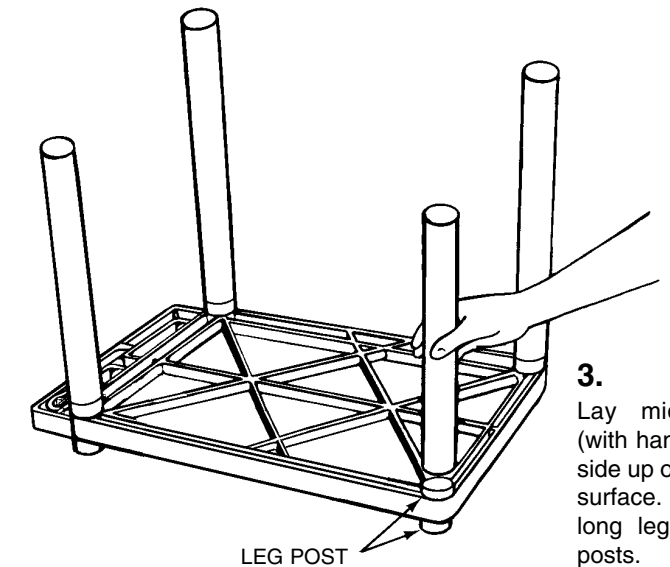

3. Lay middle shelf (with handle) ribbed side up on a smooth surface. Push all 4 long legs onto leg posts.

For LEM-32TWRT

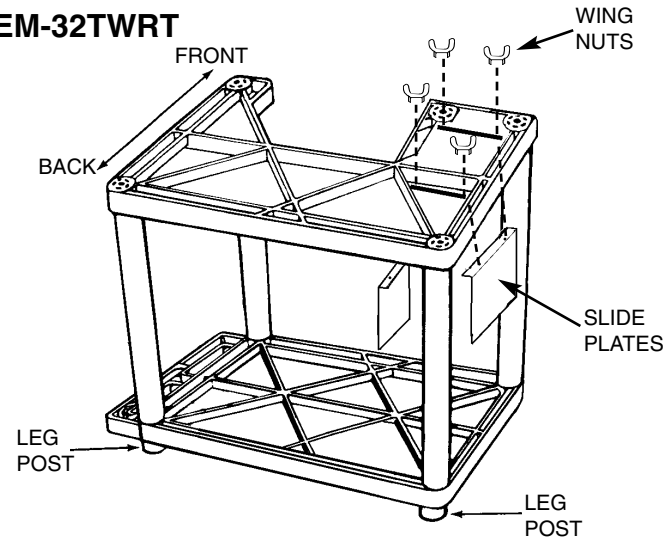

4. Position bottom shelf with open cut-out facing toward the front, ribbed side up, over the 4 legs of the top shelf as illustrated. Insert leg posts into legs. Using a rubber mallet, firmly hammer bottom shelf into legs until all four legs are seated (flush) against the surfaces of both shelves. Insert side plates (as shown) with lip facing in. Hold in place with wing nuts. Tighten when CPU is in place.

For LEM-32T & LE-MST

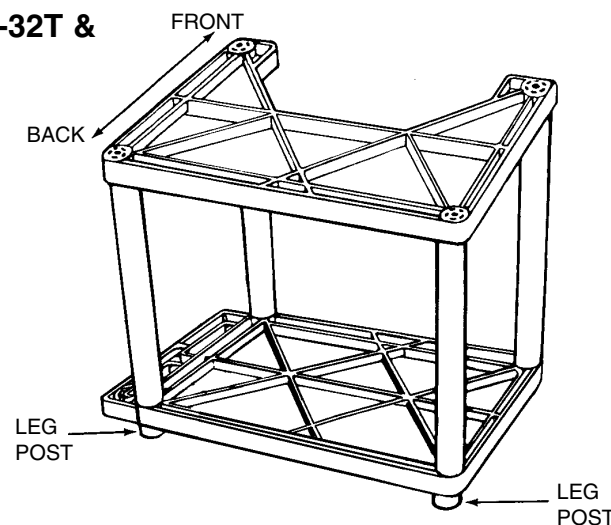

4. Position bottom shelf with open cut-out facing toward the front, ribbed side up, over the 4 legs of the top shelf as illustrated. Insert leg posts into legs. Using a rubber mallet, firmly hammer bottom shelf into legs until all four legs are seated (flush) against the surfaces of both shelves.

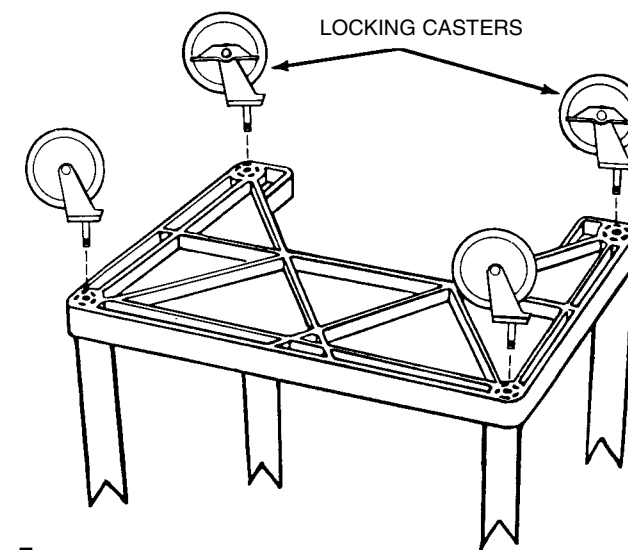

5. Push the four casters firmly into the holes in each corner of the bottom shelf. **Important:** casters must be fully seated. Tap firmly with rubber mallet to properly seat casters. Turn your Endura Workstation right side up. **Note:** LEM-32TWRT has five 2" casters.

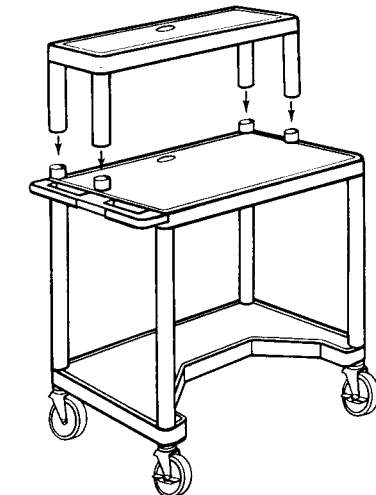

6. Set terminal platform as completed in Step No. 2 right side up and set its legs onto leg posts of middle shelf. Grommet hole should be to the back of terminal platform. Firmly hammer terminal platform with legs onto leg posts of middle shelf until legs are seated (flush) against the surface of middle shelf and terminal platform. Your Endura Computer Workstation is now ready for use.