

# Instruction Sheet

## Model LLTS24



Customer Service Dept  
2245 Delany Rd  
Waukegan, IL 60087

Ph: 847/244-1800 • 800/323-4656  
Fax: 847/244-1818 • 800/327-1698



**LLTS24**

### Parts List

- A Side panel, right & left 1 pc (in Box B)
- B Base, 1pc (in Box B)
- C Back panel, right & left 1 pc (in Box C)
- D Top panel, 1 pc (in Box B)
- E Handle, 1 pc (in Box C)
- F Doors, right & left 1 pc (in Box B)
- G Back door, 1 pc (in Box B)
- H Shelf, 7 pcs (in Box A)

- I M8×16 cup head screws 4 pcs (in Box C)
- J M5×16 cup head screws 14 pcs (in Box C)
- K M8×16 hexagonal head screws 20 pcs (in Box C)
- L 4×12 Self-tapping screws 25 pcs (in Box C)
- M Handle nuts plate, 2 pcs (in Box C)
- N Castors, 4 pcs (in Box C)
- O 28 pcs shelf support
- P 4 pcs locking bar cover

### Step 1

Attach left and right panels **A** to the base **B**. Push down firmly to assure attachment. Note: flip assembly upside down to view underside of base **B**. Tighten down side panels **A** to base **B** with 4 screws **I**. Upright assembly again. Note: be sure to have the slots of the side panels **A** toward the rear of the bottom base **B** which will leave the opposite side with 6 holes at the top front of the base **B**.

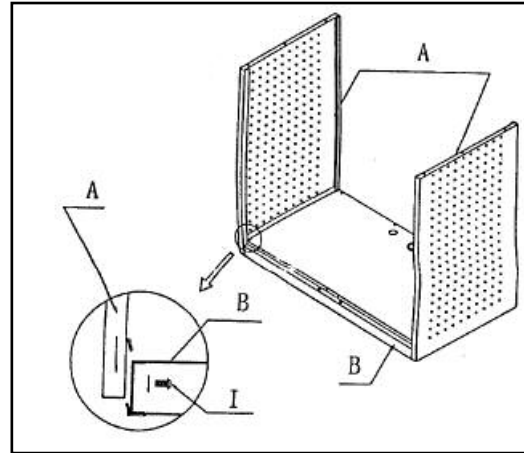

### Step 2

The tabs of the back panels **C** left and right are inserted into the slots of the side panels **A** left and right. Turn assembly either on a side or upside down to secure the back panels **C** with screws, washers and nuts **J** to the base **B**.

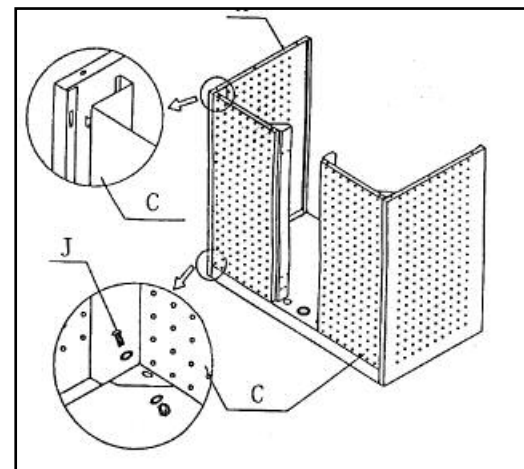

### Step 3

Attach handle **E** to top **D** by aligning the handle nut plates **M** over the inside holes screwing the hexagonal head screws **K** through the handle and top **D** into the handle nut plates on both sides, see illustration. Align mating holes place top **D** into place over side and back panels **A** and **C** with the handle to the preferred side. Once holes are aligned join the parts with bolts, nuts and washers **J**. Turn assembly upside down to install the castors **N**. The castors that swivel and have breaks should be attached to the base **B** on the handle **E** side of the cart using hexagonal head screws **K**. Return the assembled unit to its upright position

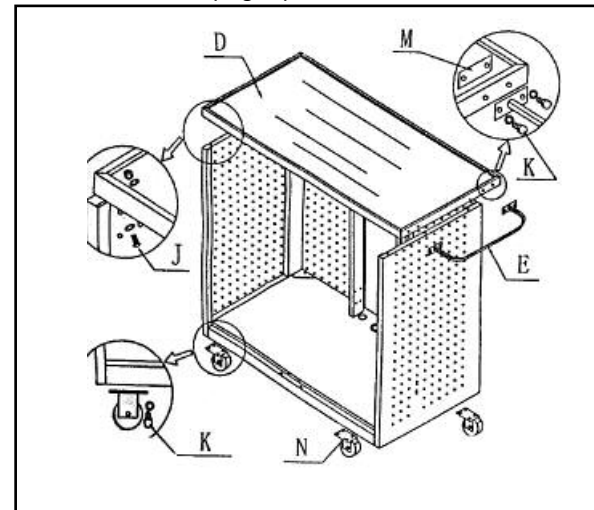

### Step 4

Front doors **F** are to be screwed into side panels **A**. With 6 self-tapping screws **L** per door.

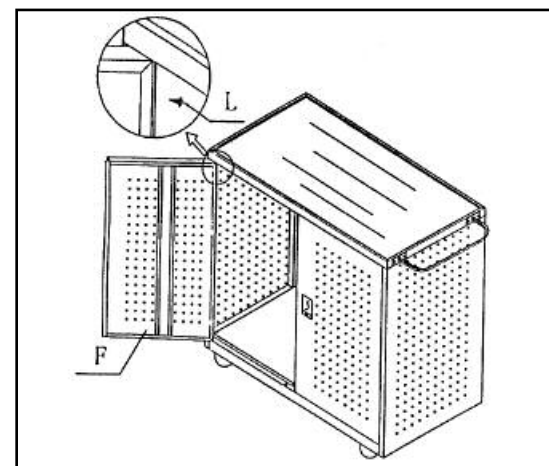

### Step 5

Repeat process to attach back door **G** to back panel **C**. Can be mounted to open on left or right side.

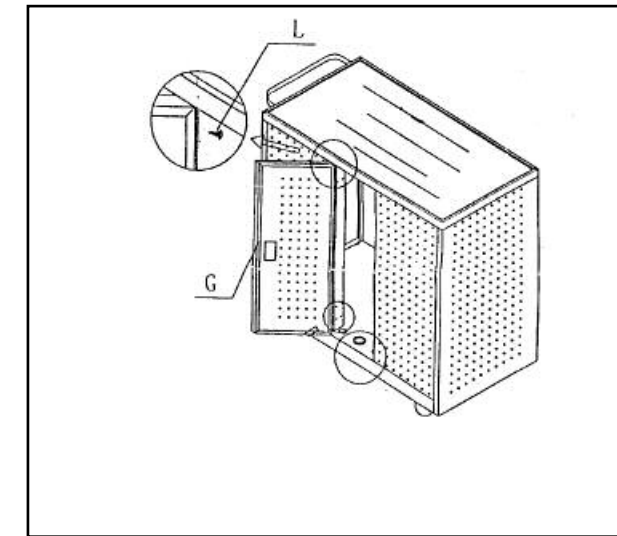

### Step 6

When installing shelves **H** the bottom 2 shelves need to be installed first. See photo for orientation of shelf support brackets. Stack the remaining shelves on top of the lower two and install them from top to bottom.

